

REVISIONS					
P	LTR	DESCRIPTION	DATE	DWN	APVD
	D1	REV PER ECR 06-014599	16JUN06	JR	MS
	D2	REVISED PER ECO-16-017419	15MAR2017	RS	DR

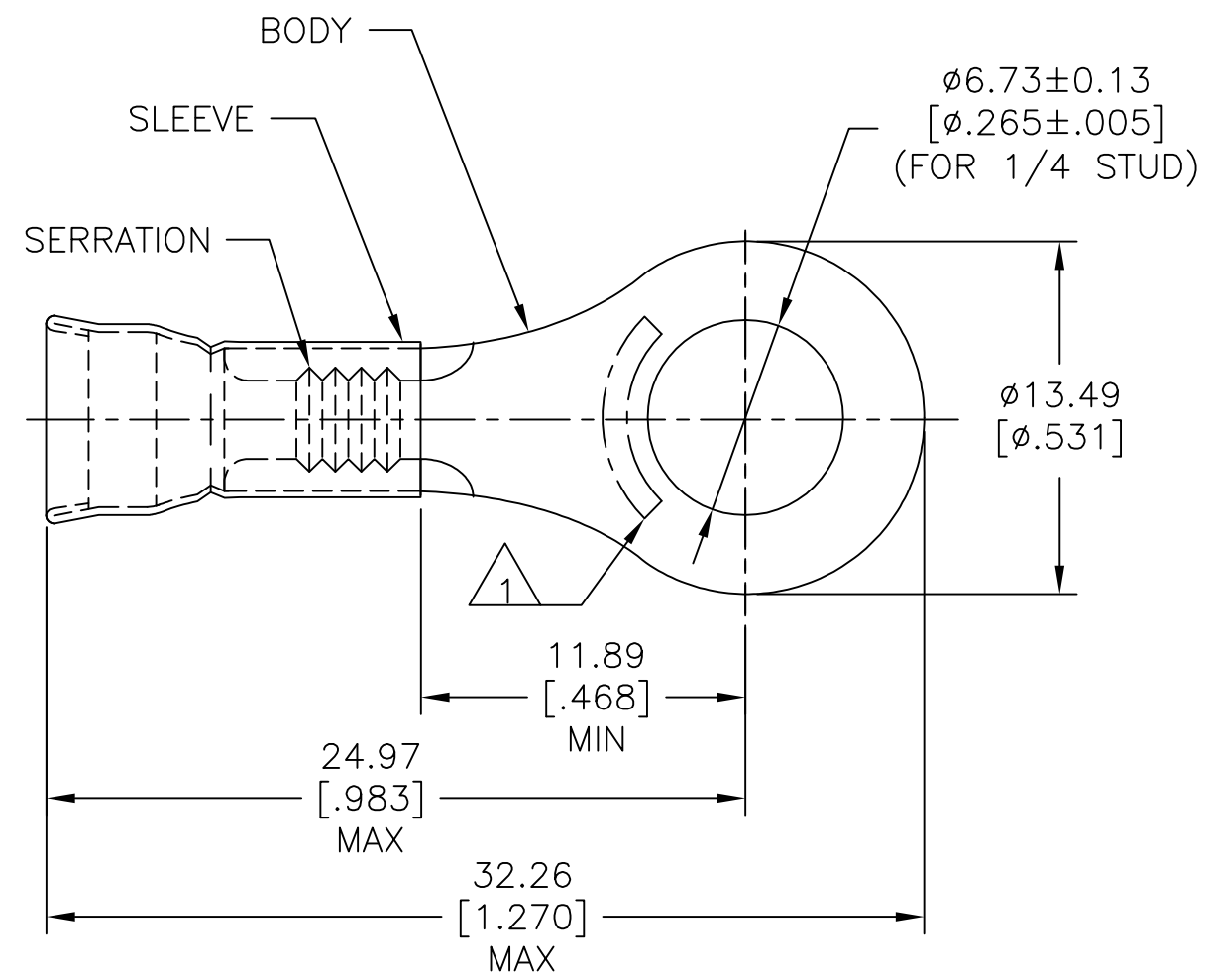

AMP WIRE RANGE	Listed FILE E13288	LR7189 Certified
12-10 AWG SOLID OR STRANDED	12-10 AWG P/N 31772 ONLY	12-10 AWG P/N 31772 ONLY

- 1 STAMP AMP 12-10* LOCATE APPROX AS SHOWN.
- 2 WIRE INSUL DIA, $\phi 3.81-5.84$ [$\phi .150-.230$].
- 3 TONGUE MATL THK, 1.02 ± 0.05 [$.040\pm .002$].
- 4 TIN PLATE PER ASTM B-545.
- 5 NOTE DELETED.
- 6 MATERIAL: BODY - CU PER ASTM B152
SLEEVE - CU PER ASTM B152.

	500	LOOSE PIECE	31772
FINISH	QTY	PACKAGE TYPE	PART NO

AMP INCORPORATED CUSTOMER SERVICE SYSTEMS	
FOR ADDITIONAL PRODUCT INFORMATION OR COPIES OF DRAWINGS AND TECHNICAL DOCUMENTS	PRODUCT INFORMATION CENTER 1-800-522-6752
FOR APPLICATION TOOLING INFORMATION	TOOLING ASSISTANCE CENTER 1-800-722-1111
FOR ORDER ENTRY	1-800-526-5142

MAX RECOMMENDED OPERATING TEMPERATURE: 170°C [338°F]
VOLTAGE RATING: -
CIRCULAR MIL AREA: 2.62-6.64mm ² [5,180-13,100] SOLID OR STRANDED

THIS DRAWING IS A CONTROLLED DOCUMENT.	
DIMENSIONS: mm [INCHES]	TOLERANCES UNLESS OTHERWISE SPECIFIED:
	0 PLC ± - 1 PLC ± - 2 PLC ± 0.20 [.008] 3 PLC ± - 4 PLC ± - ANGLES ± -
MATERIAL	FINISH
	SEE TABLE

DWN L OLMEDA 23JAN95	TE Connectivity NAME TERMINAL, RING, DIAMOND GRIP, WIRE SIZE: 12-10 AWG
CHK M ELLIS 23JAN95	
APVD S BORTNER 23JAN95	
PRODUCT SPEC UL486A	
APPLICATION SPEC	RESTRICTED TO
WEIGHT	SIZE
-	A300779
CUSTOMER DRAWING	DRAWING NO
SCALE	4:1
SHEET	1 OF 1
REV	D2