

**SMPS MOSFET**

IRF3709PbF  
IRF3709SPbF  
IRF3709LPBF

HEXFET® Power MOSFET

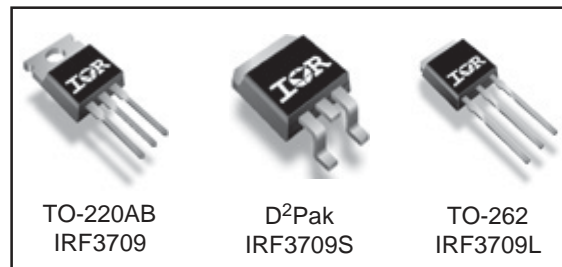
**Applications**

- High Frequency Isolated DC-DC Converters with Synchronous Rectification for Telecom and Industrial Use
- High Frequency Buck Converters for Server Processor Power Synchronous FET
- Optimized for Synchronous Buck Converters Including Capacitive Induced Turn-on Immunity
- Lead-Free

|                        |                               |                        |
|------------------------|-------------------------------|------------------------|
| <b>V<sub>DSS</sub></b> | <b>R<sub>DS(on)</sub> max</b> | <b>I<sub>D</sub></b>   |
| <b>30V</b>             | <b>9.0mΩ</b>                  | <b>90A<sup>Ⓒ</sup></b> |

**Benefits**

- Ultra-Low Gate Impedance
- Very Low RDS(on) at 4.5V V<sub>GS</sub>
- Fully Characterized Avalanche Voltage and Current



**Absolute Maximum Ratings**

| Symbol                                  | Parameter                                       | Max.            | Units |
|---|---|-----------------|-------|
| V <sub>DS</sub>                         | Drain-Source Voltage                            | 30              | V     |
| V <sub>GS</sub>                         | Gate-to-Source Voltage                          | ± 20            | V     |
| I <sub>D</sub> @ T <sub>C</sub> = 25°C  | Continuous Drain Current, V <sub>GS</sub> @ 10V | 90 <sup>Ⓒ</sup> | A     |
| I <sub>D</sub> @ T <sub>C</sub> = 100°C | Continuous Drain Current, V <sub>GS</sub> @ 10V | 57              |       |
| I <sub>DM</sub>                         | Pulsed Drain Current <sup>Ⓓ</sup>               | 360             |       |
| P <sub>D</sub> @ T <sub>C</sub> = 25°C  | Maximum Power Dissipation <sup>Ⓒ</sup>          | 120             | W     |
| P <sub>D</sub> @ T <sub>A</sub> = 25°C  | Maximum Power Dissipation <sup>Ⓔ</sup>          | 3.1             | W     |
|   | Linear Derating Factor                          | 0.96            | mW/°C |
| T <sub>J</sub> , T <sub>STG</sub>       | Junction and Storage Temperature Range          | -55 to + 150    | °C    |

**Thermal Resistance**

|                  | Parameter  | Typ. | Max. | Units |
|------------------|--|------|------|-------|
| R <sub>θJC</sub> | Junction-to-Case                                 | —    | 1.04 | °C/W  |
| R <sub>θCS</sub> | Case-to-Sink, Flat, Greased Surface <sup>Ⓓ</sup> | 0.50 | —    |       |
| R <sub>θJA</sub> | Junction-to-Ambient <sup>Ⓓ</sup>                 | —    | 62   |       |
| R <sub>θJA</sub> | Junction-to-Ambient (PCB mount) <sup>Ⓔ</sup>     | —    | 40   |       |

Notes <sup>Ⓓ</sup> through <sup>Ⓔ</sup> are on page 11

# IRF3709/S/LPbF

International  
**IR** Rectifier

## Static @ $T_J = 25^\circ\text{C}$ (unless otherwise specified)

|                                 | Parameter                            | Min. | Typ.  | Max. | Units | Conditions   |
|---------------------------------|--------------------------------------|------|-------|------|-------|--|
| $V_{(BR)DSS}$                   | Drain-to-Source Breakdown Voltage    | 30   | —     | —    | V     | $V_{GS} = 0V, I_D = 250\mu A$                        |
| $\Delta V_{(BR)DSS}/\Delta T_J$ | Breakdown Voltage Temp. Coefficient  | —    | 0.029 | —    | V/°C  | Reference to $25^\circ\text{C}, I_D = 1mA$           |
| $R_{DS(on)}$                    | Static Drain-to-Source On-Resistance | —    | 6.4   | 9.0  | mΩ    | $V_{GS} = 10V, I_D = 15A$ ③                          |
|                                 |                                      | —    | 7.4   | 10.5 |       | $V_{GS} = 4.5V, I_D = 12A$ ③                         |
| $V_{GS(th)}$                    | Gate Threshold Voltage               | 1.0  | —     | 3.0  | V     | $V_{DS} = V_{GS}, I_D = 250\mu A$                    |
| $I_{DSS}$                       | Drain-to-Source Leakage Current      | —    | —     | 20   | μA    | $V_{DS} = 24V, V_{GS} = 0V$                          |
|                                 |                                      | —    | —     | 100  |       | $V_{DS} = 24V, V_{GS} = 0V, T_J = 125^\circ\text{C}$ |
| $I_{GSS}$                       | Gate-to-Source Forward Leakage       | —    | —     | 200  | nA    | $V_{GS} = 16V$                                       |
|                                 | Gate-to-Source Reverse Leakage       | —    | —     | -200 |       | $V_{GS} = -16V$                                      |

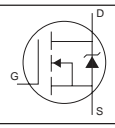
## Dynamic @ $T_J = 25^\circ\text{C}$ (unless otherwise specified)

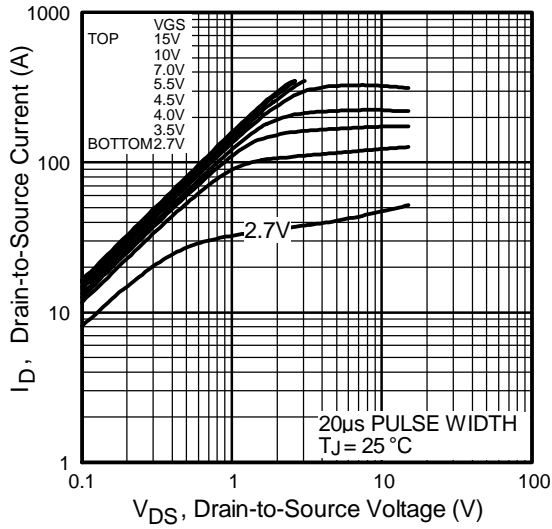
| Symbol       | Parameter                       | Min. | Typ. | Max. | Units | Conditions                  |
|--------------|---------------------------------|------|------|------|-------|-----------------------------|
| $g_{fs}$     | Forward Transconductance        | 53   | —    | —    | S     | $V_{DS} = 15V, I_D = 30A$   |
| $Q_g$        | Total Gate Charge               | —    | 27   | 41   | nC    | $I_D = 15A$                 |
| $Q_{gs}$     | Gate-to-Source Charge           | —    | 6.7  | —    |       | $V_{DS} = 16V$              |
| $Q_{gd}$     | Gate-to-Drain ("Miller") Charge | —    | 9.7  | —    |       | $V_{GS} = 5.0V$ ③           |
| $Q_{oss}$    | Output Gate Charge              | —    | 22   | —    |       | $V_{GS} = 0V, V_{DS} = 10V$ |
| $t_{d(on)}$  | Turn-On Delay Time              | —    | 11   | —    | ns    | $V_{DD} = 15V$              |
| $t_r$        | Rise Time                       | —    | 171  | —    |       | $I_D = 30A$                 |
| $t_{d(off)}$ | Turn-Off Delay Time             | —    | 21   | —    |       | $R_G = 1.8\Omega$           |
| $t_f$        | Fall Time                       | —    | 9.2  | —    |       | $V_{GS} = 4.5V$ ③           |
| $C_{iss}$    | Input Capacitance               | —    | 2672 | —    | pF    | $V_{GS} = 0V$               |
| $C_{oss}$    | Output Capacitance              | —    | 1064 | —    |       | $V_{DS} = 16V$              |
| $C_{rss}$    | Reverse Transfer Capacitance    | —    | 109  | —    |       | $f = 1.0MHz$                |

## Avalanche Characteristics

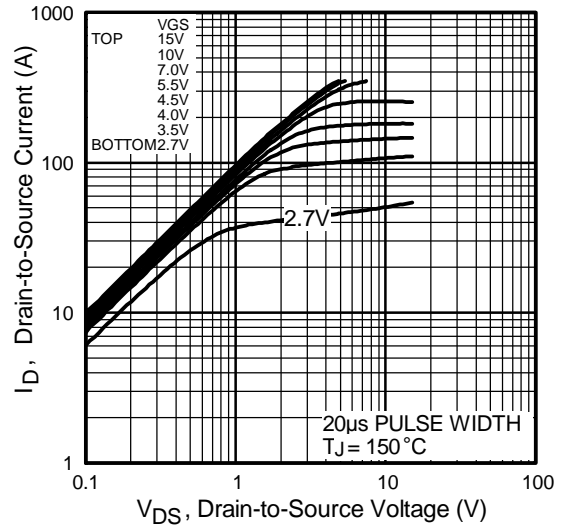
| Symbol   | Parameter                      | Typ. | Max. | Units |
|----------|--------------------------------|------|------|-------|
| $E_{AS}$ | Single Pulse Avalanche Energy② | —    | 382  | mJ    |
| $I_{AR}$ | Avalanche Current①             | —    | 30   | A     |

## Diode Characteristics

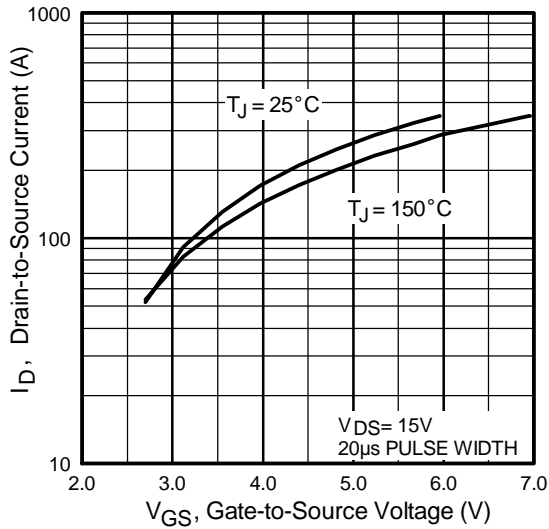
| Symbol   | Parameter                                 | Min. | Typ. | Max. | Units | Conditions   |
|----------|---|------|------|------|-------|--|
| $I_S$    | Continuous Source Current<br>(Body Diode) | —    | —    | 90⑥  | A     | MOSFET symbol showing the integral reverse p-n junction diode.  |
| $I_{SM}$ | Pulsed Source Current<br>(Body Diode) ①   | —    | —    | 360  |       |  |
| $V_{SD}$ | Diode Forward Voltage                     | —    | 0.88 | 1.3  | V     | $T_J = 25^\circ\text{C}, I_S = 30A, V_{GS} = 0V$ ③   |
|          |   | —    | 0.82 | —    |       | $T_J = 125^\circ\text{C}, I_S = 30A, V_{GS} = 0V$ ③  |
| $t_{rr}$ | Reverse Recovery Time                     | —    | 48   | 72   | ns    | $T_J = 25^\circ\text{C}, I_F = 30A, V_R = 15V$   |
| $Q_{rr}$ | Reverse Recovery Charge                   | —    | 46   | 69   | nC    | $di/dt = 100A/\mu s$ ③   |
| $t_{rr}$ | Reverse Recovery Time                     | —    | 48   | 72   | ns    | $T_J = 125^\circ\text{C}, I_F = 30A, V_R = 15V$  |
| $Q_{rr}$ | Reverse Recovery Charge                   | —    | 52   | 78   | nC    | $di/dt = 100A/\mu s$ ③   |



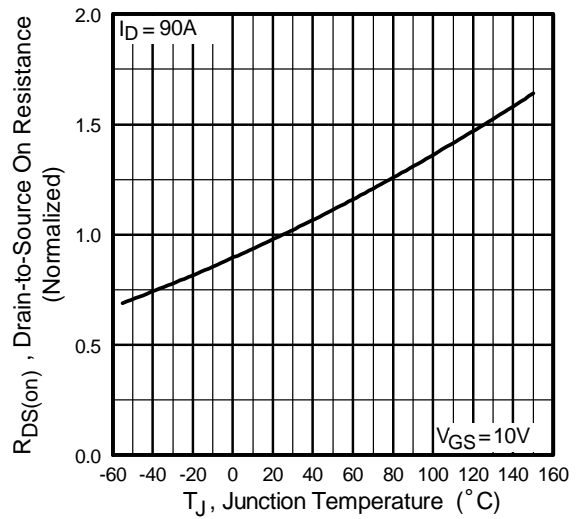
**Fig 1.** Typical Output Characteristics



**Fig 2.** Typical Output Characteristics

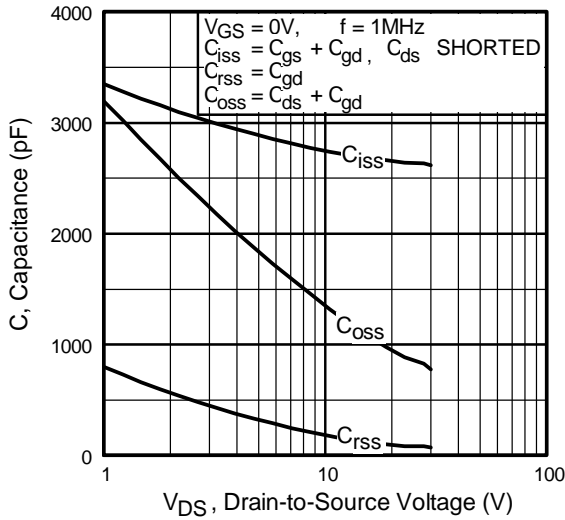


**Fig 3.** Typical Transfer Characteristics

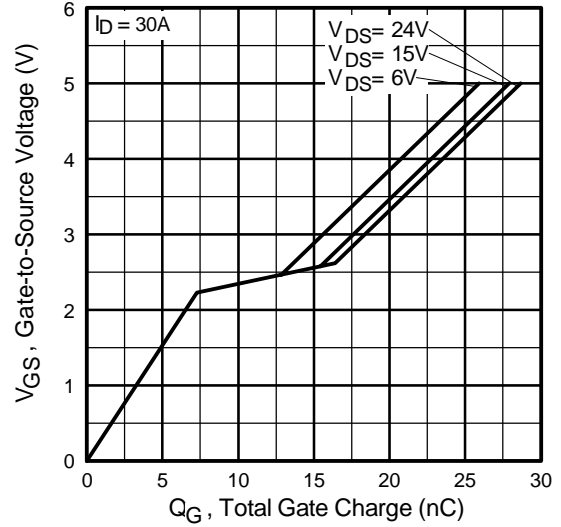


**Fig 4.** Normalized On-Resistance Vs. Temperature

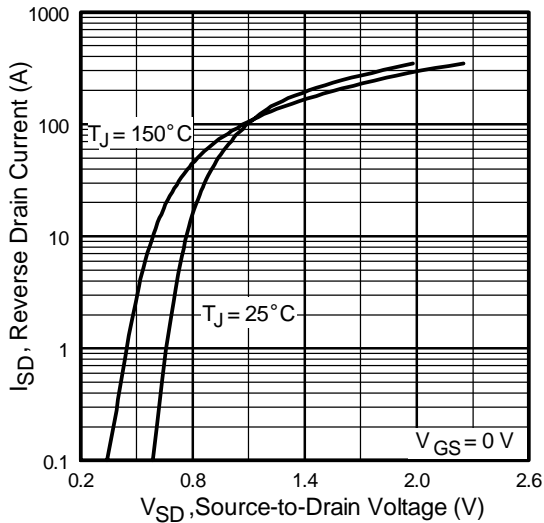
# IRF3709/S/LPbF



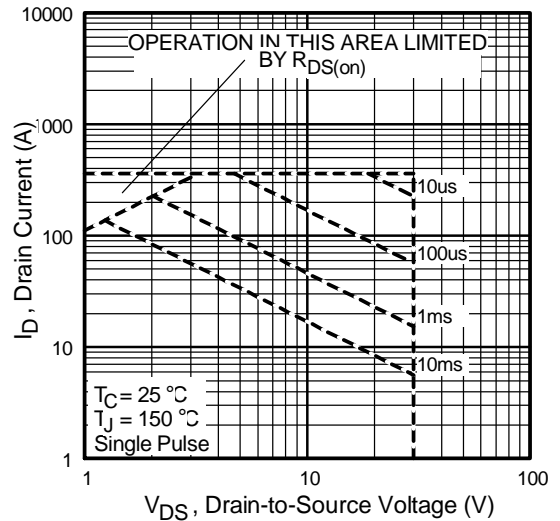
**Fig 5.** Typical Capacitance Vs. Drain-to-Source Voltage



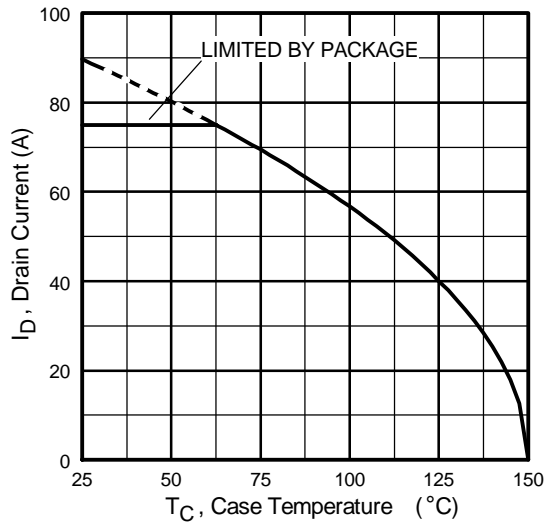
**Fig 6.** Typical Gate Charge Vs. Gate-to-Source Voltage



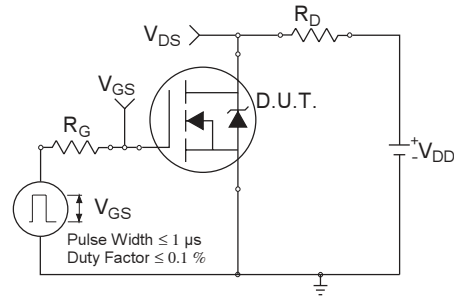
**Fig 7.** Typical Source-Drain Diode Forward Voltage



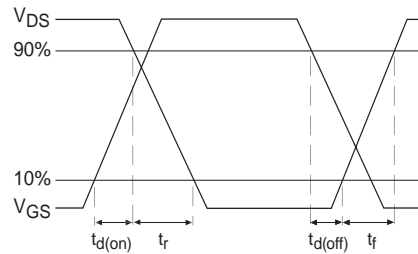
**Fig 8.** Maximum Safe Operating Area



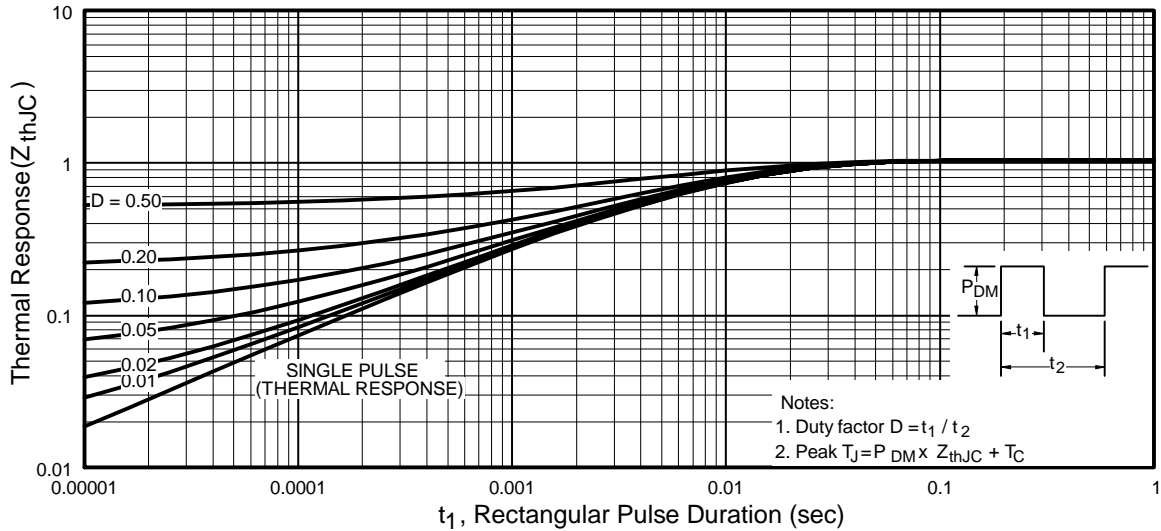
**Fig 9.** Maximum Drain Current Vs. Case Temperature



**Fig 10a.** Switching Time Test Circuit



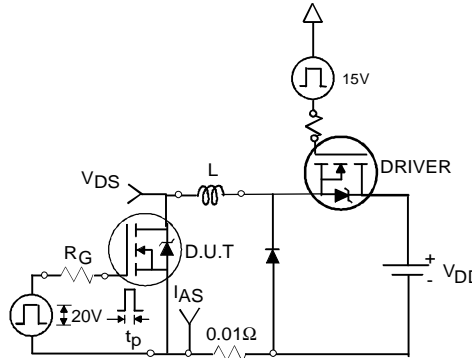
**Fig 10b.** Switching Time Waveforms



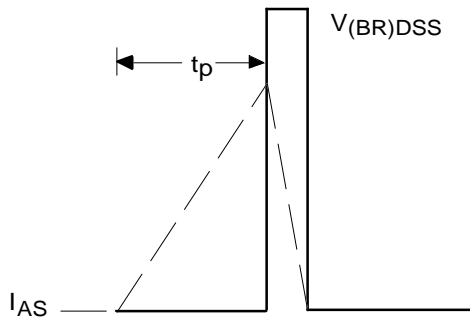
**Fig 11.** Maximum Effective Transient Thermal Impedance, Junction-to-Case

# IRF3709/S/LPbF

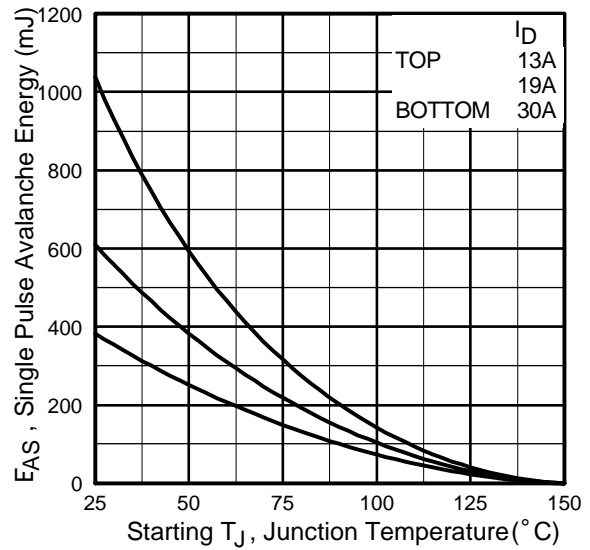
International  
**IR** Rectifier



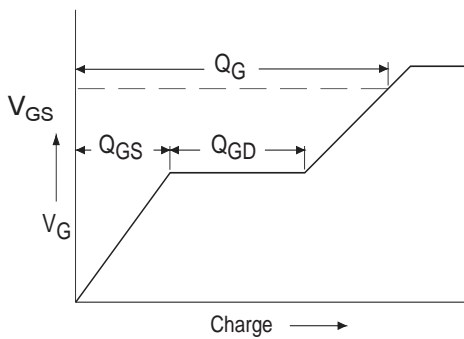
**Fig 12a.** Unclamped Inductive Test Circuit



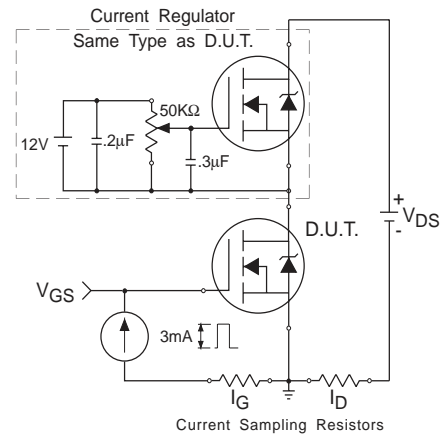
**Fig 12b.** Unclamped Inductive Waveforms



**Fig 12c.** Maximum Avalanche Energy Vs. Drain Current

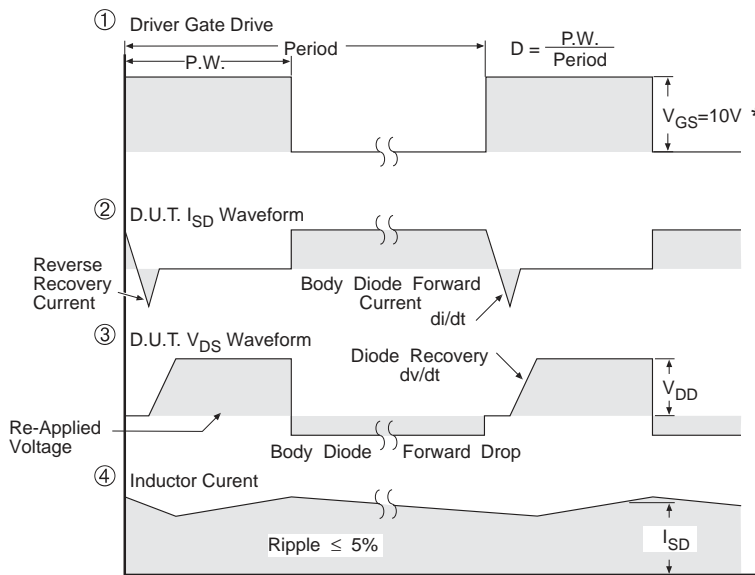
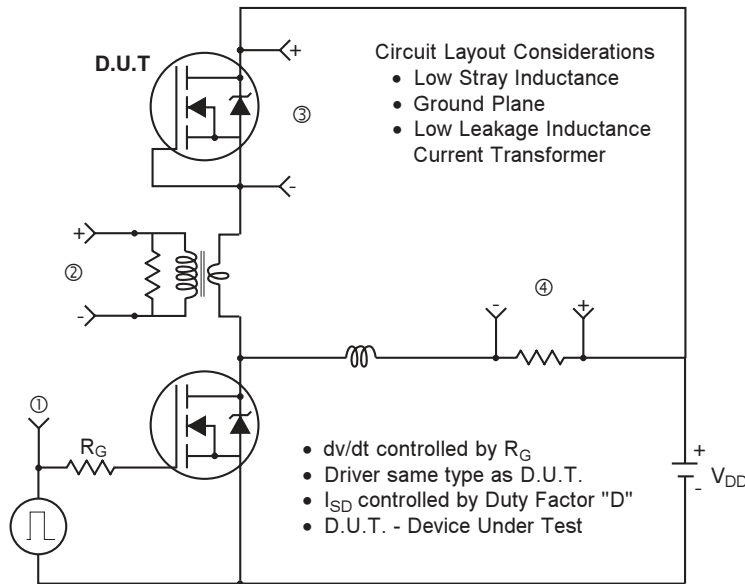


**Fig 13a.** Basic Gate Charge Waveform



**Fig 13b.** Gate Charge Test Circuit

**Peak Diode Recovery dv/dt Test Circuit**



\*  $V_{GS} = 5V$  for Logic Level Devices

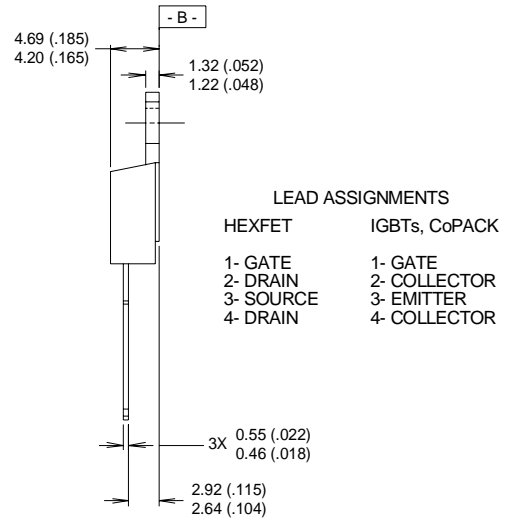
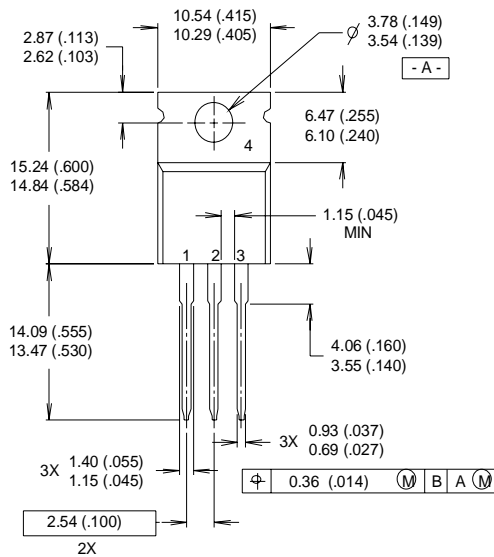
**Fig 14.** For N-Channel HEXFET® Power MOSFETs

# IRF3709/S/LPbF



## TO-220AB Package Outline

Dimensions are shown in millimeters (inches)

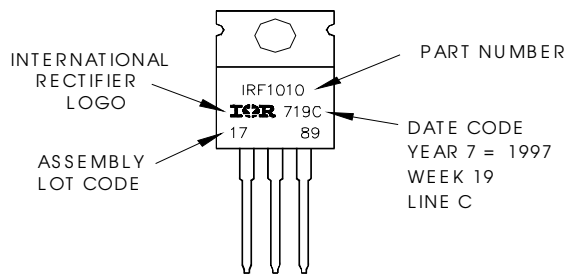


**NOTES:**

- 1 DIMENSIONING & TOLERANCING PER ANSI Y14.5M, 1982.
- 2 CONTROLLING DIMENSION : INCH
- 3 OUTLINE CONFORMS TO JEDEC OUTLINE TO-220AB.
- 4 HEATSINK & LEAD MEASUREMENTS DO NOT INCLUDE BURRS.

## TO-220AB Part Marking Information

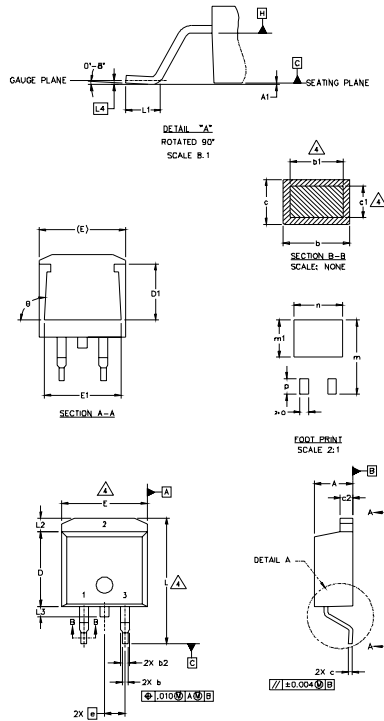
EXAMPLE: THIS IS AN IRF1010  
 LOT CODE 1789  
 ASSEMBLED ON WW 19, 1997  
 IN THE ASSEMBLY LINE "C"  
**Note:** "P" in assembly line position indicates "Lead-Free"





## D<sup>2</sup>Pak Package Outline

Dimensions are shown in millimeters (inches)



| SYMBOL | DIMENSIONS  |       |          |      | NOTES |
|--------|-------------|-------|----------|------|-------|
|        | MILLIMETERS |       | INCHES   |      |       |
|        | MIN.        | MAX.  | MIN.     | MAX. |       |
| A      | 4.06        | 4.83  | .160     | .190 | 4     |
| A1     |             | 0.127 |          | .005 |       |
| b      | 0.51        | 0.99  | .020     | .039 |       |
| b1     | 0.51        | 0.89  | .020     | .035 |       |
| b2     | 1.14        | 1.40  | .045     | .055 | 4     |
| c      | 0.43        | 0.63  | .017     | .025 |       |
| c1     | 0.38        | 0.74  | .015     | .029 | 3     |
| c2     | 1.14        | 1.40  | .045     | .055 |       |
| D      | 8.51        | 9.65  | .335     | .380 | 3     |
| D1     | 5.33        |       | .210     |      |       |
| E      | 9.65        | 10.67 | .380     | .420 | 3     |
| E1     | 6.22        |       | .245     |      |       |
| e      | 2.54 BSC    |       | .100 BSC |      |       |
| L      | 14.61       | 15.88 | .575     | .625 |       |
| L1     | 1.78        | 2.79  | .070     | .110 |       |
| L2     |             | 1.65  |          | .065 |       |
| L3     | 1.27        | 1.78  | .050     | .070 |       |
| L4     | 0.25 BSC    |       | .010 BSC |      |       |
| m      | 17.78       |       | .700     |      |       |
| m1     | 8.89        |       | .350     |      |       |
| n      | 11.43       |       | .450     |      |       |
| o      | 2.08        |       | .082     |      |       |
| p      | 3.81        |       | .150     |      |       |
| θ      | 90°         | 93°   | 90°      | 93°  |       |

**LEAD ASSIGNMENTS**

| HEXFET     | IGBTs - CoPACK | DIODES      |
|------------|----------------|-------------|
| 1.- GATE   | 1.- GATE       | 1.- ANODE * |
| 2.- DRAIN  | 2.- COLLECTOR  | 2.- CATHODE |
| 3.- SOURCE | 3.- EMITTER    | 3.- ANODE   |

\* PART DEPENDENT.

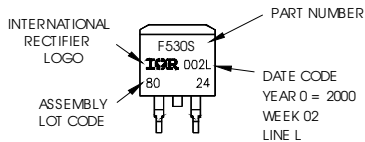
**NOTES:**

1. DIMENSIONING AND TOLERANCING PER ASME Y14.5M-1994
2. DIMENSIONS ARE SHOWN IN MILLIMETERS [INCHES]
3. DIMENSION D & E DO NOT INCLUDE MOLD FLASH. MOLD FLASH SHALL NOT EXCEED 0.127 [0.005"] PER SIDE. THESE DIMENSIONS ARE MEASURED AT THE OUTMOST EXTREMES OF THE PLASTIC BODY.
4. DIMENSION b1 AND c1 APPLY TO BASE METAL ONLY.
5. CONTROLLING DIMENSION: INCH.

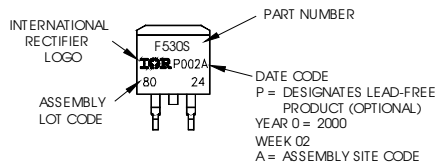
## D<sup>2</sup>Pak Part Marking Information

EXAMPLE: THIS IS AN IRF530S WITH LOT CODE 8024 ASSEMBLED ON WW02, 2000 IN THE ASSEMBLY LINE 'L'

Note: 'P' in assembly line position indicates 'Lead-Free'



**OR**

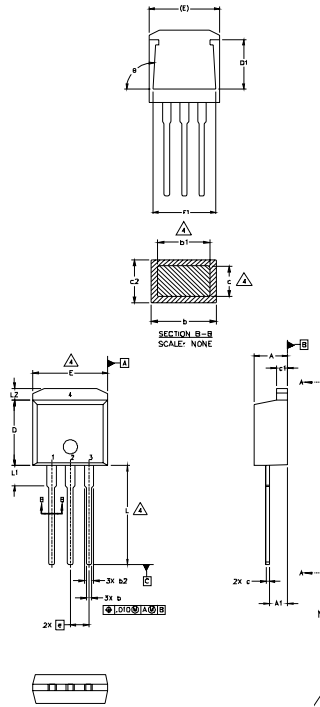


# IRF3709/S/LPbF



## TO-262 Package Outline

Dimensions are shown in millimeters (inches)



| SYMBOL | DIMENSIONS  |       |        |      | NOTES |
|--------|-------------|-------|--------|------|-------|
|        | MILLIMETERS |       | INCHES |      |       |
|        | MIN.        | MAX.  | MIN.   | MAX. |       |
| A      | 4.06        | 4.83  | .160   | .190 |       |
| A1     | 2.03        | 2.92  | .080   | .115 |       |
| b      | 0.51        | 0.99  | .020   | .039 |       |
| b1     | 0.51        | 0.89  | .020   | .035 | 4     |
| b2     | 1.14        | 1.40  | .045   | .055 |       |
| c      | 0.38        | 0.63  | .015   | .025 | 4     |
| c1     | 1.14        | 1.40  | .045   | .055 |       |
| c2     | 0.43        | .063  | .017   | .029 |       |
| D      | 8.51        | 9.65  | .335   | .380 | 3     |
| D1     | 5.33        |       | .210   |      |       |
| E      | 9.65        | 10.67 | .380   | .420 | 3     |
| E1     | 6.22        |       | .245   |      |       |
| e      | 2.54        | BSC   | .100   | BSC  |       |
| L      | 13.46       | 14.09 | .530   | .555 |       |
| L1     | 3.56        | 3.71  | .140   | .146 |       |
| L2     |             | 1.65  |        | .065 |       |

### LEAD ASSIGNMENTS

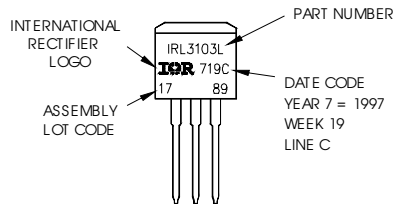
| HEXFET     | IGBT          |
|------------|---------------|
| 1 - GATE   | 1 - GATE      |
| 2 - DRAIN  | 2 - COLLECTOR |
| 3 - SOURCE | 3 - EMITTER   |
| 4 - DRAIN  |               |

- NOTES:
1. DIMENSIONING AND TOLERANCING PER ASME Y14.5M-1994
  2. DIMENSIONS ARE SHOWN IN MILLIMETERS [INCHES].
  3. DIMENSION D & E DO NOT INCLUDE MOLD FLASH. MOLD FLASH SHALL NOT EXCEED 0.127 [0.005"] PER SIDE. THESE DIMENSIONS ARE MEASURED AT THE OUTMOST EXTREMES OF THE PLASTIC BODY.
  4. DIMENSION D1 AND c1 APPLY TO BASE METAL ONLY.
  5. CONTROLLING DIMENSION: INCH.

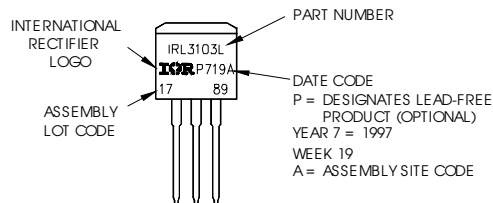
## TO-262 Part Marking Information

EXAMPLE: THIS IS AN IRL3103L  
 LOT CODE 1789  
 ASSEMBLED ON VW 19, 1997  
 IN THE ASSEMBLY LINE 'C'

Note: "P" in assembly line position indicates "Lead-Free"

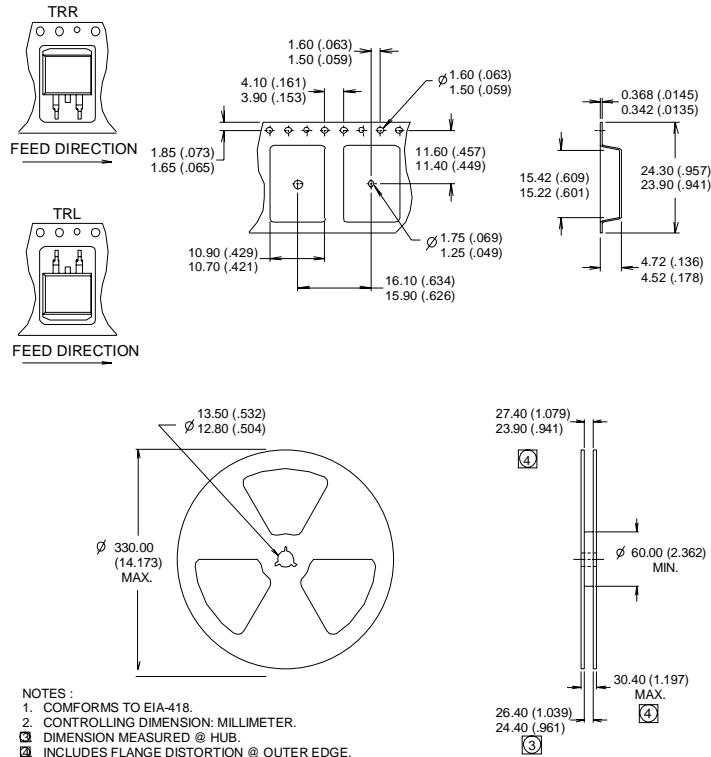


OR



## D<sup>2</sup>Pak Tape & Reel Information

Dimensions are shown in millimeters (inches)



### Notes:

- ① Repetitive rating; pulse width limited by max. junction temperature.
- ② Starting  $T_J = 25^\circ\text{C}$ ,  $L = 0.85\text{mH}$   
 $R_G = 25\Omega$ ,  $I_{AS} = 30\text{A}$ .
- ③ Pulse width  $\leq 400\mu\text{s}$ ; duty cycle  $\leq 2\%$ .
- ④ This is only applied to TO-220AB package.
- ⑤ This is applied to D<sup>2</sup>Pak, when mounted on 1" square PCB (FR-4 or G-10 Material).  
 For recommended footprint and soldering techniques refer to application note #AN-994.
- ⑥ Calculated continuous current based on maximum allowable junction temperature. Package limitation current is 75A.

Data and specifications subject to change without notice.  
 This product has been designed and qualified for the industrial market.  
 Qualification Standards can be found on IR's Web site.

Note: For the most current drawings please refer to the IR website at:  
<http://www.irf.com/package/>