

- 1
- 2
- 3
- 4
- 5
- 6
- 7
- 8
- 9
- 10
- 11
- 12
- 13
- 14
- 15
- RH

MATERIAL

Glass-fibre reinforced polypropylene based (PP) technopolymer, black colour, matte finish.

BOSS CAP

Acetal resin based technopolymer (POM), black colour, matte finish; press-fit assembly.

STANDARD EXECUTION

Black-oxide steel boss, H9 hole with keyway in compliance with DIN 6885/1 tolerance P9 (see page A-16).

Revolving handle IEL+x SOFT in technopolymer coated with "soft-touch" thermoplastic elastomer (TPE), black colour, matte finish, not removable.

INDEXING PLUNGER

Black-oxide steel indexing plunger with glass-fibre reinforced polyamide based (PA) technopolymer handle, black colour, matte finish. Black-oxide steel plunger.

In the locking position (crank handle blocked) the indexing plunger comes out to 10 mm and seats in one of the especially drilled holes provided on the wall of the structure (fig.1).

In the operating position (crank handle free to rotate) the indexing plunger is lifted and rotated by 90 ° so that it remains in the raised position (fig.2).

SPECIAL EXECUTIONS ON REQUEST

Execution with locking device, see drawing.

EIK. crank handle can be supplied in other colours or customised with marks, logo or special graphics (tampoprinting).



ERGOSTYLE® ELESA Original design

Execution with locking device and latch

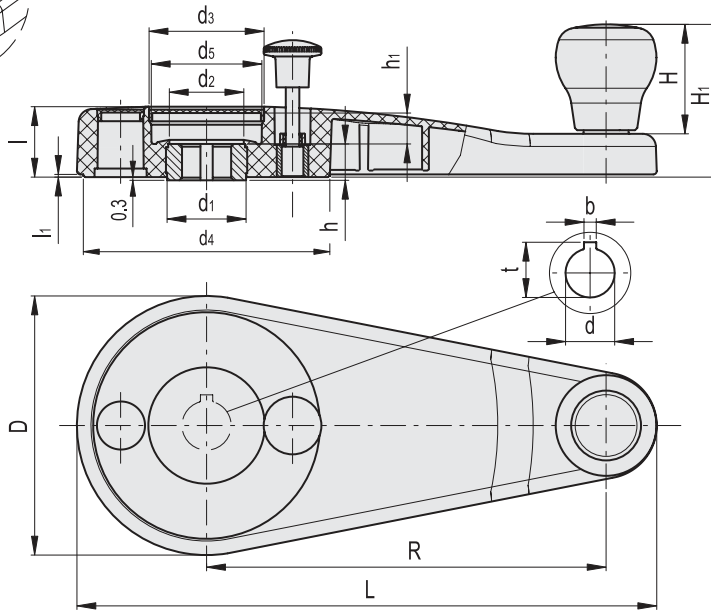
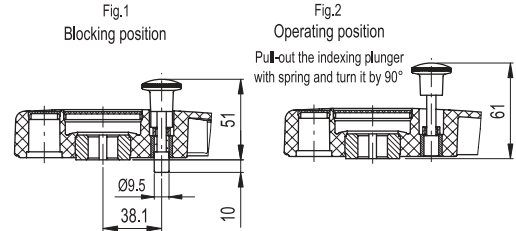
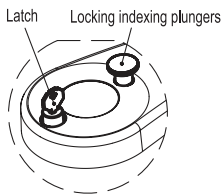

Conversion Table	
1 mm = 0.039 inch	
R	
mm	inch
210	8.27

METRIC

Code	Description	R	dH9	t+0.1	bP9	L	D	d1	d2	d3	d4	d5	l	l1	h	h1	H	H1	C# [Nm]	L# [J]	△
208411-C1	EIK.210+IEL A-20-C1	210	20	22.8	6	290	115	35	33	50	109	48	31	1.5	15	14	47	68	180	14	425