

f:1:RL

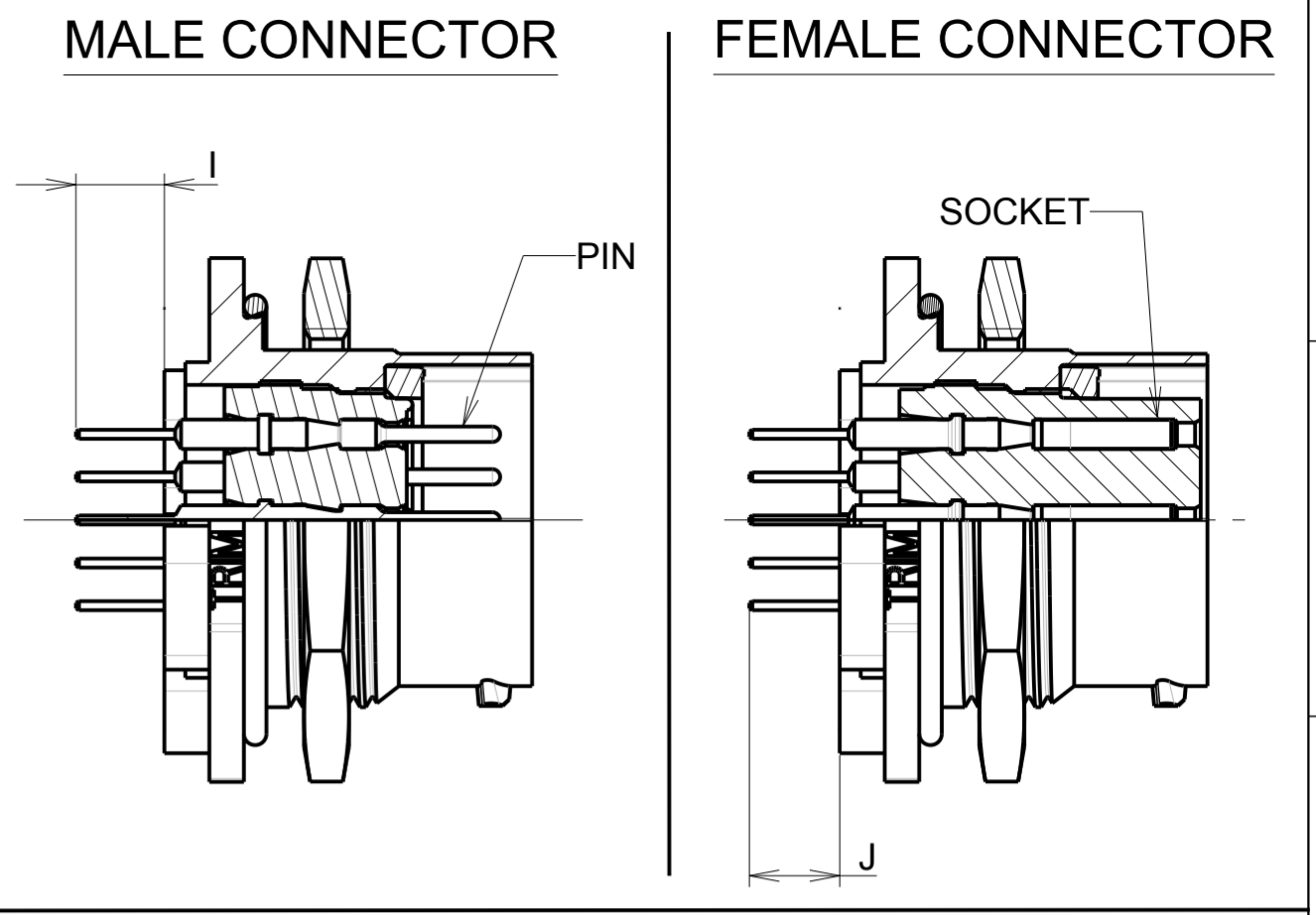

SHELL SIZE	ØA ±0.15	B ±0.20 (without marking)	C ±0.20	C ±0.37 specif. 30	D	ØE	F ± 0.3	Thread	Tightening torque (Nut)
08	11.90	24.00	19.05 ±0.37	19.05	13.75 ± 0.20	14.60 ± 0.20	3.1	9/16 24 UNEF CLASS 2A	2 Nm
10	14.90	26.90	22.15	22.20	16.40 0/+0.2	17.30 0/+0.25	3.1	11/16 24 UNEF CLASS 2A	3 Nm
12	18.95	31.75	27.15	26.97	20.85 0/+0.3	22.10 0/+0.3	3.1	7/8 20 UNEF CLASS 2A	4 Nm
14	22.15	34.90	30.20	30.15	24.00 0/+0.3	25.40 0/+0.3	3 ± 0.1	1"20 UNEF CLASS 2A	5 Nm

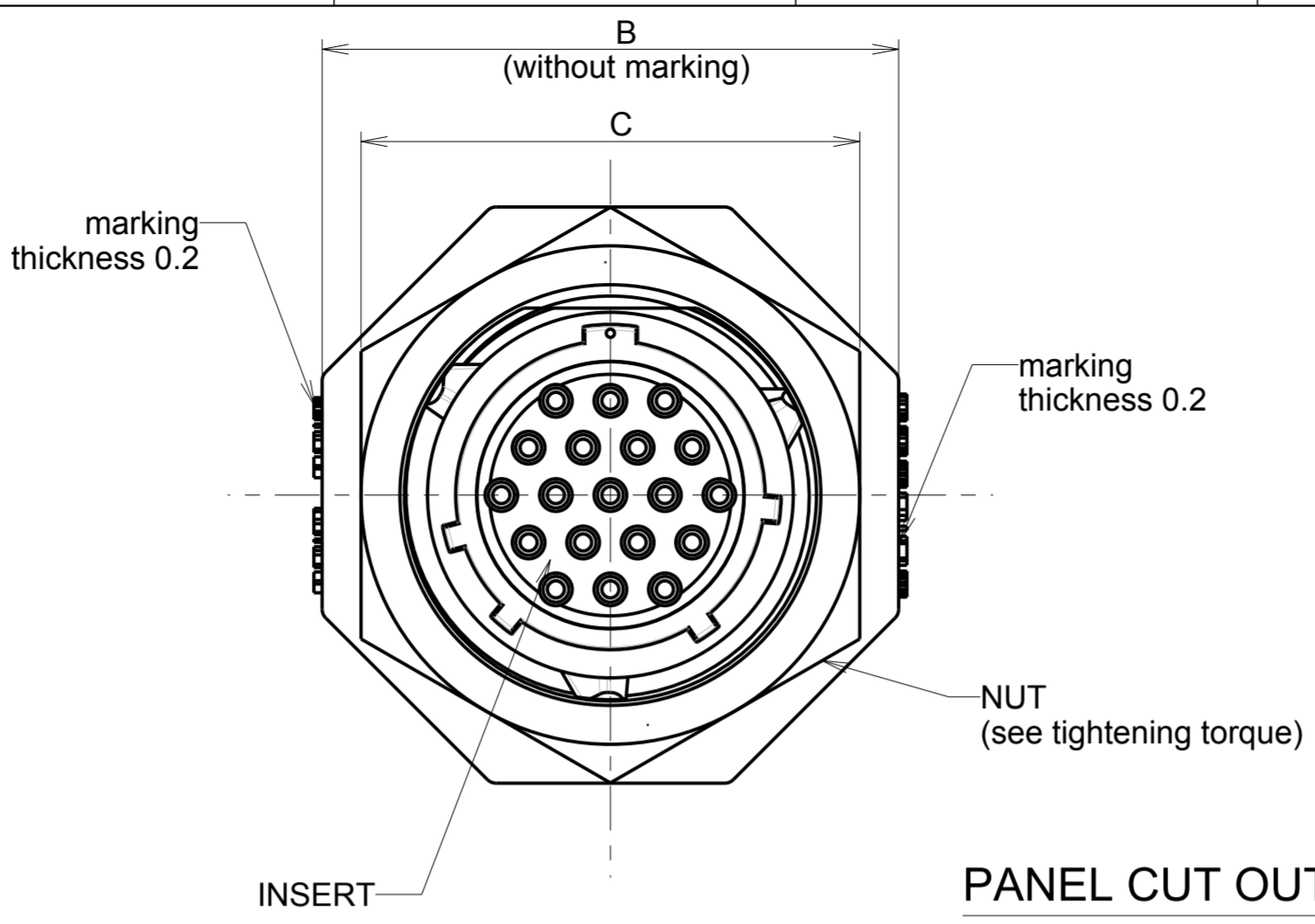
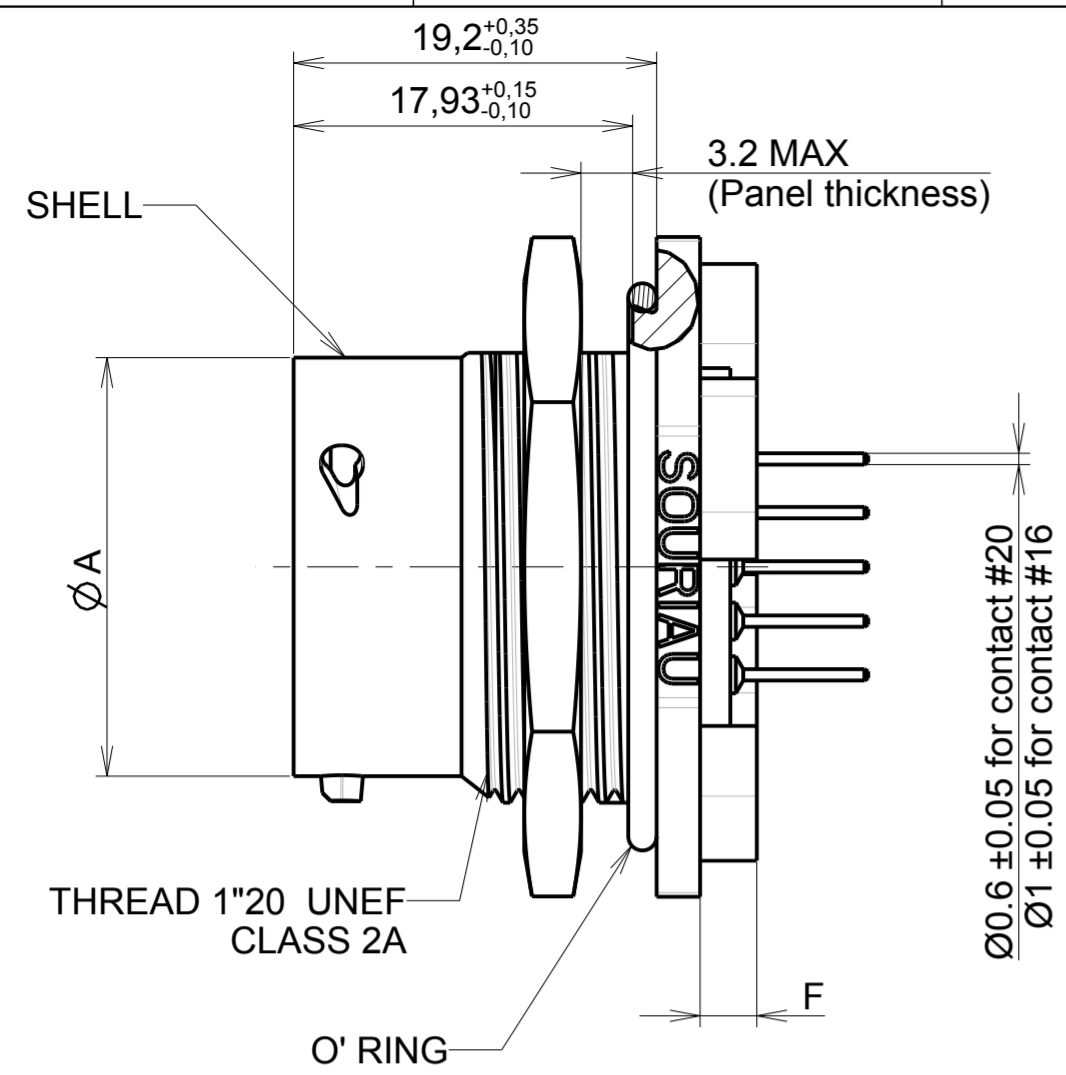
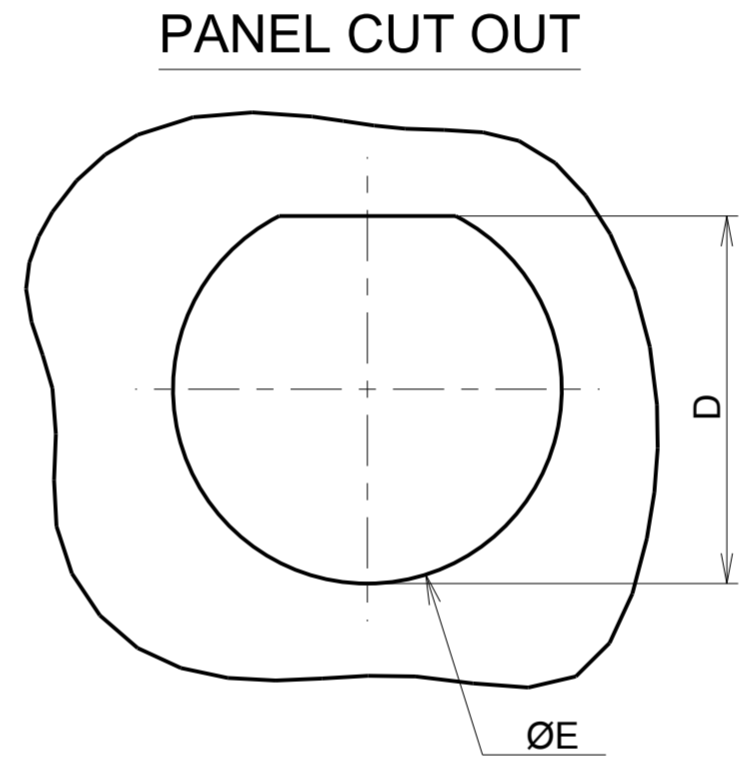

Shell size	I (male connector)	J (female connector)
8	3.8/6 for layout 8-2/8-3/8-4 4.7/7.25 for layout 8-3A/8-98/8-33	3.75/5.8 for layout 8-2/8-3/8-4 4.8/6.9 for layout 8-3A/8-98/8-33
10	4.9/7	4.9/7
12	4.8/7 3.85/5.9 for layout 12-14	5.2/7 3.85/5.9 for layout 12-14
14	4.8/7	5.3/7

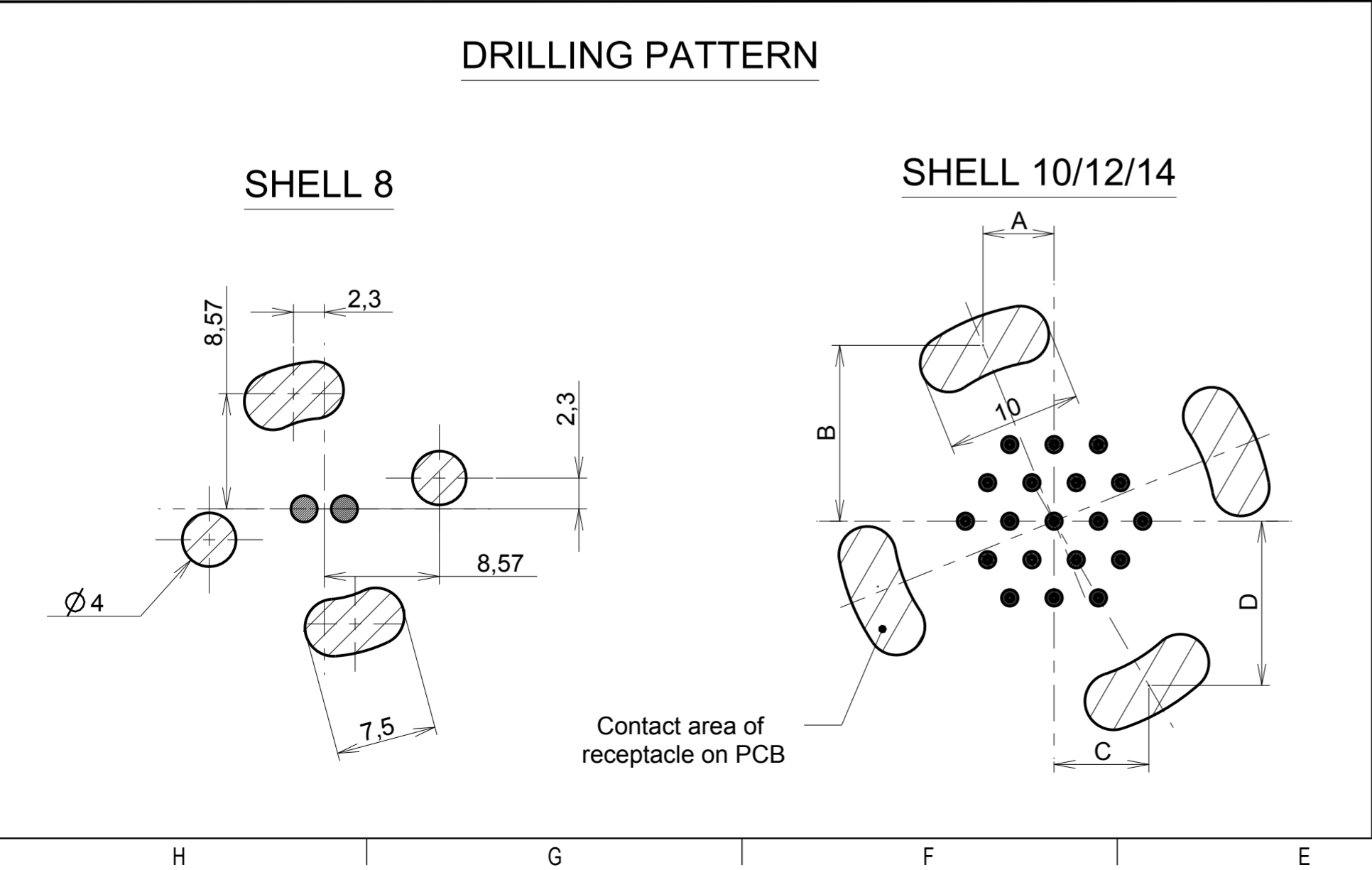
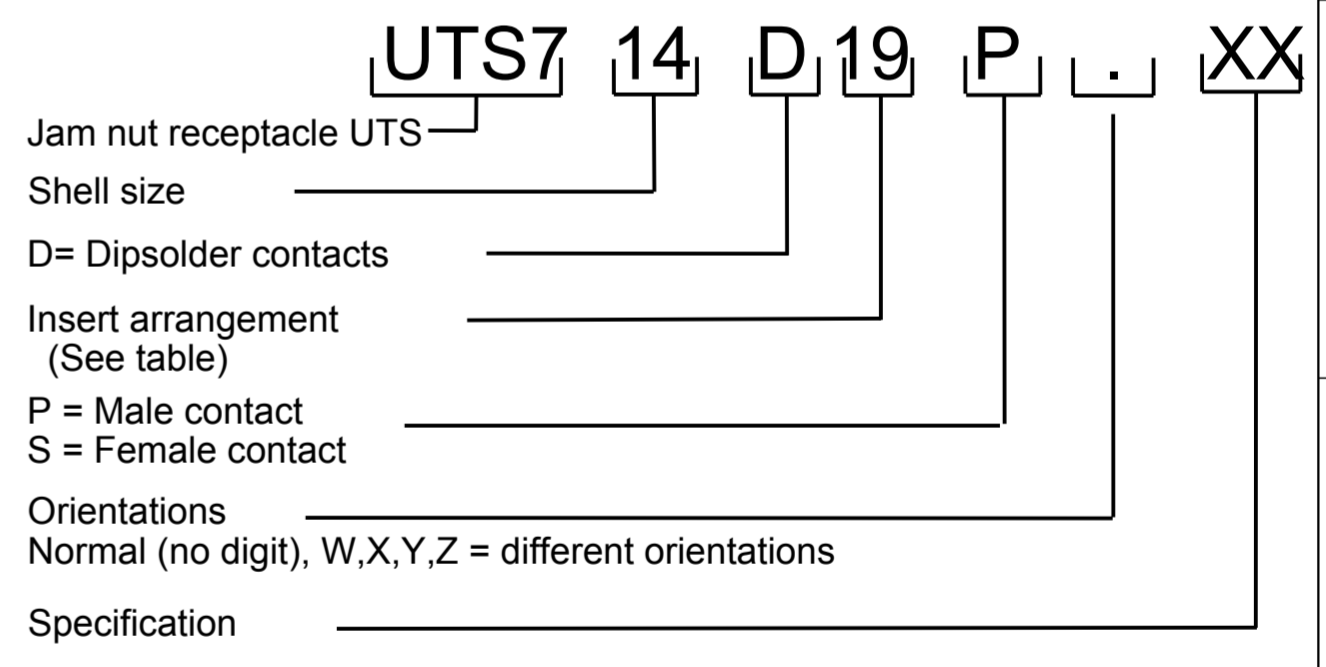

**MATERIAL :**  
 - Shell: Polyamid UL94 V-0  
 - Insert: Polychloropren (CR)  
 - Seal gasket : Sealing IP68/69K : Silicone  
 - O'ring: nitril  
 - Nut: Aluminium alloy black anodized  
 - Contact: Brass + gold plated

**PERFORMANCE CHARACTERISTICS :**  
 - Operating temperature: -40°C up to 105°C  
 - Insulation resistance: 5000 MΩ min  
 - Test potential: 2000 Vrms for #16 layout and 1500Vrms for #20 layout  
 - Corrosion salt spray: 500 hours  
 - Durability: 250 matings and unmatings

- Sealing in mated and unmated conditions:  
 -IP68 : 1 bar during 1 week : immersion under 10 of water (IEC 60529)  
 -IP69K : exposure to high pressure water of cleaning equipement(DIN 40050)

**NOTE :**  
 - Insert arrangements : refer to C144-UTS1-A

TAILLE	Perçage 1		Perçage 2	
	A	B	C	D
T10	3.98	9.85	5.31	9.20
T12	4.92	12.17	6.56	11.37
T14	5.29	13.10	7.06	12.23

**CUSTOMER DRAWING**

f	05/12/13	DRILLING PATTERN: Modification of view and cotation	
ISS	DATE	Latest modification - by:	LANDAIS.P
Designed by: <b>SORIN V.</b>		Date: 23/10/08	<b>CUSTOMER DRAWING</b>
TITLE		JAM NUT RECEPTACLE WITH DIPSOLDER CONTACTS	
		UTS HI SEAL	
Scale	3/1	General linear Tolerances: ± 0.2	NPRDS / PROJECT UTS
<b>SOURIAU</b>		<b>WWW.SOURIAU.COM</b>	
FORMAT		SOURIAU DRG N° C061-UTS1-A	
A2		SHEET 1/1	

NOT EXPORT CONTROLLED