

1

2

3

4

5

RoHS Compliant

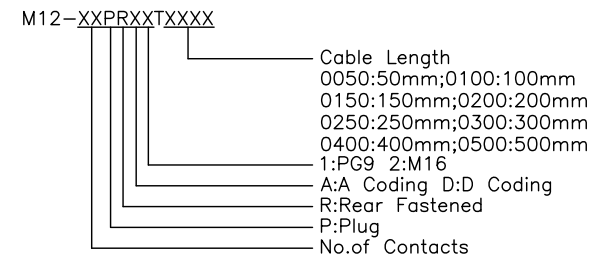
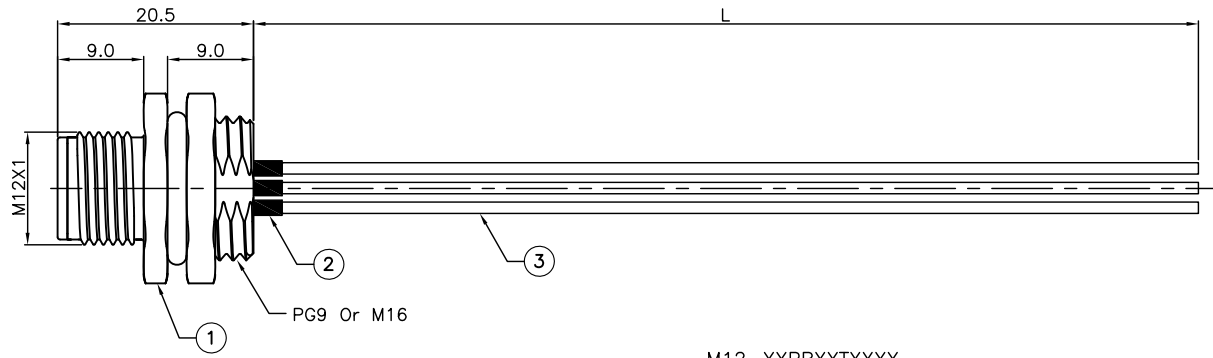
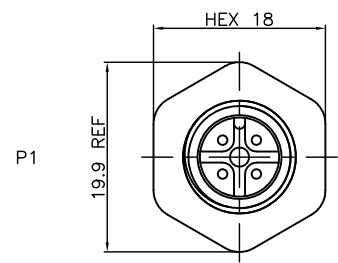

A Coding						
D Coding						

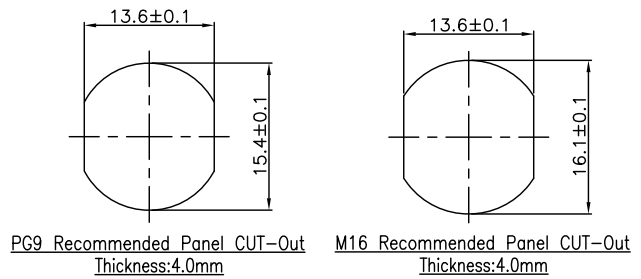

ITEM	PART NO.	DESCRIPTION	Q'TY
1	M12-XXP-RX-PMX	M12 Plug Rear Fastened Solder Type	1
2	825-H.S-XX-BK	Heat Shrink Tube Color:Black	A/R
3	809-TPEXXTSW-XX	TPE XXAWG Wire Color:XX	A/R

F				DRAWN:	Andrew	GENERAL TOLERANCE:	
E				CHECKED:	Bill He	.X=±0.50	L≤300=±5
D						.XX=±0.30	L>300=±10
C				APPROVAL:	Bill He	UNIT: MM	
B						SCALE: 1:1	
A	01-Jul-2022		Andrew			SHEET: 1/2	
REV	DATE	FILE	BY			PROJECTION:	

OST
ON-SHORE TECHNOLOGY, INC.

DESCRIPTION:
M12 PLUG REAR FASTENED WIRE HARNESS

PART NO:
M12-XXPRXXTXXXX

A
B
C
D

1

2

3

4

5

RoHS Compliant

2P PIN OUT:

P1	
1	Black
3	Brown

ITEM	PART NO.	DESCRIPTION	Q'TY
1	M12-02P-RX-PMX	M12 2Pin Plug Rear Fastened Solder Type	1
2	825-H.S-XX-BK	Heat Shrink Tube Color:Black	A/R
3	809-TPE22TSW-XX	TPE 22AWG Wire Color:XX	A/R

3P PIN OUT:

P1	
1	Black
3	Brown
4	Red

ITEM	PART NO.	DESCRIPTION	Q'TY
1	M12-03P-RX-PMX	M12 3Pin Plug Rear Fastened Solder Type	1
2	825-H.S-XX-BK	Heat Shrink Tube Color:Black	A/R
3	809-TPE22TSW-XX	TPE 22AWG Wire Color:XX	A/R

4P PIN OUT:

P1	
1	Black
2	White
3	Brown
4	Red

ITEM	PART NO.	DESCRIPTION	Q'TY
1	M12-04P-RX-PMX	M12 4Pin Plug Rear Fastened Solder Type	1
2	825-H.S-XX-BK	Heat Shrink Tube Color:Black	A/R
3	809-TPE22TSW-XX	TPE 22AWG Wire Color:XX	A/R

5P PIN OUT:

P1	
1	Black
2	White
3	Brown
4	Red
5	Yellow

ITEM	PART NO.	DESCRIPTION	Q'TY
1	M12-05P-RX-PMX	M12 5Pin Plug Rear Fastened Solder Type	1
2	825-H.S-XX-BK	Heat Shrink Tube Color:Black	A/R
3	809-TPE22TSW-XX	TPE 22AWG Wire Color:XX	A/R

6P PIN OUT:

P1	
1	Black
2	White
3	Brown
4	Red
5	Yellow
6	Blue

ITEM	PART NO.	DESCRIPTION	Q'TY
1	M12-06P-RX-PMX	M12 6Pin Plug Rear Fastened Solder Type	1
2	825-H.S-XX-BK	Heat Shrink Tube Color:Black	A/R
3	809-TPE24TSW-XX	TPE 24AWG Wire Color:XX	A/R

7P PIN OUT:

P1	
1	Black
2	White
3	Brown
4	Red
5	Yellow
6	Blue
7	Orange

ITEM	PART NO.	DESCRIPTION	Q'TY
1	M12-07P-RX-PMX	M12 7Pin Plug Rear Fastened Solder Type	1
2	825-H.S-XX-BK	Heat Shrink Tube Color:Black	A/R
3	809-TPE24TSW-XX	TPE 24AWG Wire Color:XX	A/R

8P PIN OUT:

P1	
1	Black
2	White
3	Brown
4	Red
5	Yellow
6	Blue
7	Orange
8	Green

ITEM	PART NO.	DESCRIPTION	Q'TY
1	M12-08P-RX-PMX	M12 8Pin Plug Rear Fastened Solder Type	1
2	825-H.S-XX-BK	Heat Shrink Tube Color:Black	A/R
3	809-TPE24TSW-XX	TPE 24AWG Wire Color:XX	A/R

9P PIN OUT:

P1	
1	Black
2	White
3	Brown
4	Red
5	Yellow
6	Blue
7	Orange
8	Green
9	Purple

ITEM	PART NO.	DESCRIPTION	Q'TY
1	M12-09P-RX-PMX	M12 9Pin Plug Rear Fastened Solder Type	1
2	825-H.S-XX-BK	Heat Shrink Tube Color:Black	A/R
3	809-TPE26TSW-XX	TPE 26AWG Wire Color:XX	A/R

10P PIN OUT:

P1	
1	Black
2	White
3	Brown
4	Red
5	Yellow
6	Blue
7	Orange
8	Green
9	Purple
10	Grey

ITEM	PART NO.	DESCRIPTION	Q'TY
1	M12-10P-RX-PMX	M12 10Pin Plug Rear Fastened Solder Type	1
2	825-H.S-XX-BK	Heat Shrink Tube Color:Black	A/R
3	809-TPE26TSW-XX	TPE 26AWG Wire Color:XX	A/R

11P PIN OUT:

P1	
1	Black
2	White
3	Brown
4	Red
5	Yellow
6	Blue
7	Orange
8	Green
9	Purple
10	Grey
11	Pink

ITEM	PART NO.	DESCRIPTION	Q'TY
1	M12-11P-RX-PMX	M12 11Pin Plug Rear Fastened Solder Type	1
2	825-H.S-XX-BK	Heat Shrink Tube Color:Black	A/R
3	809-TPE26TSW-XX	TPE 26AWG Wire Color:XX	A/R

12P PIN OUT:

P1	
1	Black
2	White
3	Brown
4	Red
5	Yellow
6	Blue
7	Orange
8	Green
9	Purple
10	Grey
11	Pink
12	Light Green

ITEM	PART NO.	DESCRIPTION	Q'TY
1	M12-12P-RX-PMX	M12 12Pin Plug Rear Fastened Solder Type	1
2	825-H.S-XX-BK	Heat Shrink Tube Color:Black	A/R
3	809-TPE26TSW-XX	TPE 26AWG Wire Color:XX	A/R

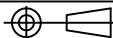
F				DRAWN: Andrew	GENERAL TOLERANCE:			ON-SHORE TECHNOLOGY, INC.	DESCRIPTION: M12 PLUG REAR FASTENED WIRE HARNESS	PART NO: M12-XXPRXXTXXXX
E					CHECKED: Bill He	.X=±0.50 .XX=±0.30				
D				APPROVAL: Bill He	UNIT: MM	SCALE: 1:1	PROJECTION: 			
C					SHEET: 2/2					
B										
A	01-Jul-2022		Andrew							
REV	DATE	FILE	BY							