

Evaluating the **AD74413R** Quad-Channel, Software Configurable Input and Output

FEATURES

Fully featured evaluation board for the **AD74413R**

On-board 2.5 V **ADR4525** reference

SPI-compatible

PC-based software for control

EVALUATION KIT CONTENTS

EV-AD74413RSDZ evaluation board

EQUIPMENT NEEDED

EVAL-SDP-CS1Z (SDP-S)

Benchtop power supply and connector cables

PC running 7 and 10 Windows® operating system

DOCUMENTS NEEDED

AD74413R data sheet

SOFTWARE NEEDED

AD74413R evaluation software

GENERAL DESCRIPTION

The EV-AD74413RSDZ (see Figure 1) is a fully featured evaluation board that can be used to evaluate the features of the **AD74413R**. The **AD74413R** is a quad-channel, software configurable, input and output device. The device has functionality for analog output, analog input, digital input, and resistance temperature detector (RTD) measurements integrated into a single chip solution with a serial peripheral interface (SPI).

The EV-AD74413RSDZ can be controlled via a system demonstration platform (**SDP**). The **SDP-S** controls the EV-AD74413RSDZ via the USB port of a PC using the **AD74413R** evaluation software.

The EV-AD74413RSDZ requires an AVDD operating supply of 14 V to 28.8 V. When the EV-AD74413RSDZ is connected to the PC, the PC powers the **SDP-S**.

See the **AD74413R** data sheet for more information about the **AD74413R**, and users must consult the data sheet in conjunction with this user guide when using the EV-AD74413RSDZ.

TABLE OF CONTENTS

Features	1	Test Points	4
Evaluation Kit Contents.....	1	Link Configuration Options	4
Equipment Needed.....	1	Software Quick Start Procedures.....	6
Documents Needed.....	1	Accessing the AD74413R Evaluation Software Graphical User Interface (GUI)	6
Software Needed	1	Configuring the EV-AD74413RSDZ.....	6
General Description	1	Using the Software for Testing.....	6
Revision History	2	Example Sequence.....	9
Evaluation Board Photograph.....	3	Discrete Digital Output Circuits	10
Evaluation Board Hardware	4	Evaluation Board Schematics.....	11
Power Supplies	4	Ordering Information.....	19
Reference Options	4	Bill of Materials.....	19
Output Channels	4		
SPI Communication.....	4		

REVISION HISTORY

11/2019—Revision 0: Initial Version

EVALUATION BOARD PHOTOGRAPH

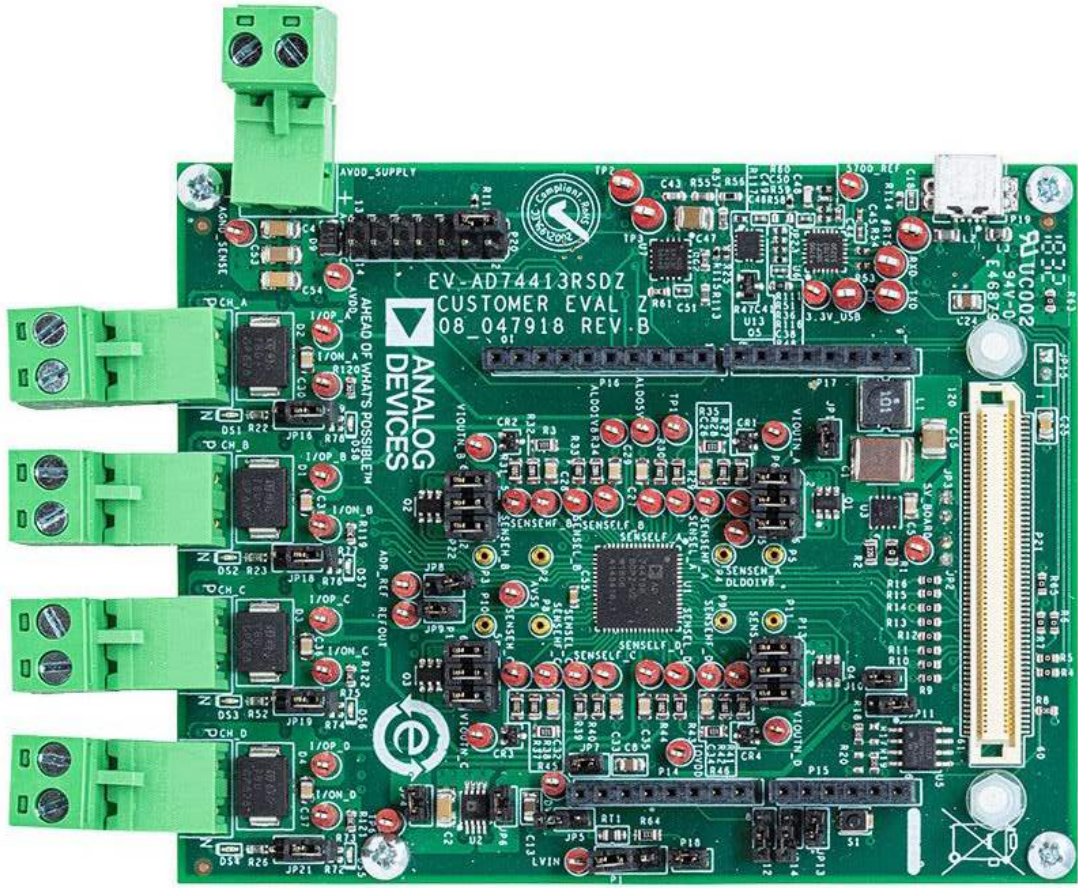

Figure 1.

EVALUATION BOARD HARDWARE

POWER SUPPLIES

The EV-AD74413RSDZ comes with a single power supply connector that directly powers the AVDD pin of the AD74413R. Set the AVDD supply as described in the AD74413R data sheet.

The EV-AD74413RSDZ AVDD supply powers an on-board regulator (ADP2360) that generates a 5 V supply to the EV-AD74413RSDZ (see Figure 2). Use the 5 V supply for the following purposes:

- To power a 2.5 V external reference (ADR4525). The ADR4525 can be used as an alternative to the AD74413R on-chip reference.
- To power a 3.3 V regulator (ADP1720). The 3.3 V from the regulator powers the DVCC and IOVDD supplies of the AD74413R.

Figure 2 shows a simplified drawing of the power connections on the EV-AD74413RSDZ.

REFERENCE OPTIONS

By default, the EV-AD74413RSDZ uses the AD74413R on-chip reference by shorting the REFOUT pin to the REFIN pin. There is also an external reference option (ADR_REF) available on the EV-AD74413RSDZ. The ADR4525 can be used as an external reference instead of using the internal reference. Connect the appropriate jumpers if using the external reference. See Table 1 for the specific link options and functions.

OUTPUT CHANNELS

The AD74413R has four channels, see the AD74413R data sheet for more information. Figure 13 shows the schematic details for all four channels.

There are four channel screw terminal connectors on the EV-AD74413RSDZ. These terminal connectors, CH_A, CH_B, CH_C, and CH_D, connect the desired loads to the four AD74413R channels.

SPI COMMUNICATION

The SDP-S board handles the communication to the EV-AD74413RSDZ via the PC. By default, the SDP-S board controls the SPI communication, the RESET pin (driven high), and LDAC pin (driven low). The SDP-S board also monitors the ALERT pin, ADC_RDY pin, and the GPO_x pins of the AD74413R.

A reset button (S1) is available on the EV-AD74413RSDZ.

The EV-AD74413RSDZ supports using an Arduino® board (such as the EVAL-ADICUP3029) when connected to the headers provided on the EV-AD74413RSDZ. See Table 1 for the necessary links to the Arduino header.

TEST POINTS

The EV-AD74413RSDZ has multiple test points. Debug access is available for all AD74413R pins and all four channel screw terminals. The test points are located adjacent to the relevant pins on the AD74413R.

LINK CONFIGURATION OPTIONS

Set the JPx and Px jumpers correctly to properly operate the EV-AD74413RSDZ before using this board. The functions and default states of these options are listed in Table 1.

Before applying power and signals to the EV-AD74413RSDZ, ensure that all links are set to the default positions defined in Table 1.

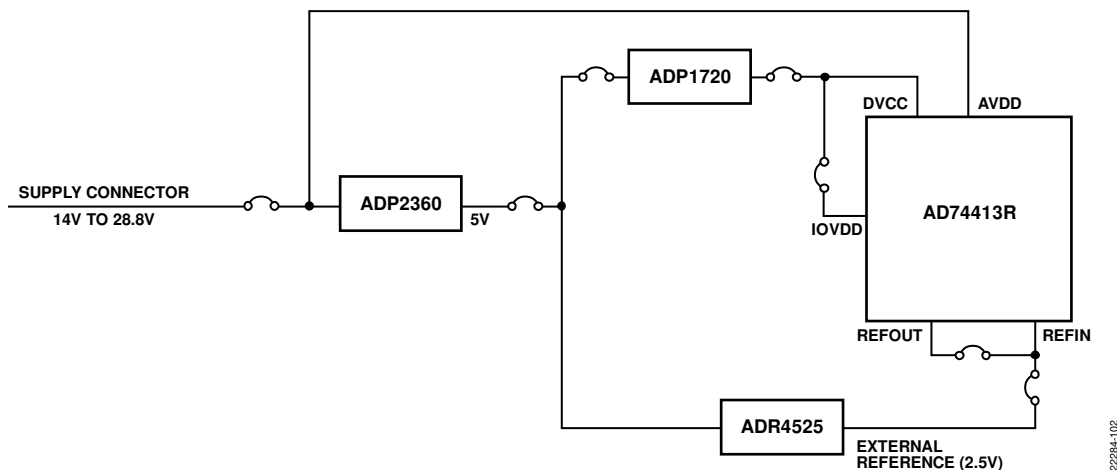

Figure 2. EV-AD74413RSDZ Simplified Power Diagram

Table 1. EV-AD74413RSDZ Link Option Functions

Link	Function	Default Position
JP1	When inserted, the AVDD supply powers the ADP2360 .	Inserted
JP2	When inserted, the Arduino connector supplies 5 V. When not inserted, use JP3 to provide the 5 V supply instead.	Not inserted
JP3	When inserted, the ADP2360 supplies 5 V. When not inserted, use JP2 to provide the 5 V supply instead.	Inserted
JP4	When inserted, 5 V powers the ADP1720 . When not inserted, no power is provided to the ADP1720 .	Inserted
JP5	When inserted, the Arduino connector supplies the DVCC voltage. When not inserted, use JP6 to provide the DVCC supply instead.	Not inserted
JP6	When inserted, the ADP1720 supplies the DVCC voltage. When not inserted, use the Arduino connector to provide the DVCC supply instead.	Inserted
JP7	When inserted, the IOVDD voltage is connected to the DVCC voltage. When not inserted, no power is supplied to the IOVDD pin.	Inserted
JP8	When inserted, the REFIN pin is tied to the output of the AD74413R .	Not inserted
JP9	When inserted, the REFIN pin is tied to the REFOUT pin (the internal reference of the AD74413R).	Inserted
JP10	When inserted, the SDP-S board provides 3.3 V. When not inserted, use JP11 to provide the 3.3 V supply instead.	Inserted
JP11	When inserted, the Arduino connector provides 3.3 V. When not inserted, use JP10 to provide the 3.3 V supply instead.	Not inserted
JP12	When inserted, the Arduino reset function can trigger the AD74413R reset.	Not inserted
JP13	When inserted, the EV-AD74413RSDZ reset button can reset the AD74413R .	Inserted
JP14	When inserted, an Arduino general-purpose input/output (GPIO) can trigger the AD74413R reset.	Not inserted
JP15	When inserted, use the 5 V supply to supply the SDP-S board.	Not inserted
JP16	When inserted, the AD74413R GPO_A pin can be configured to enable the digital output circuit on Channel A. It is important that this jumper is not inserted if the digital output circuit is not in use.	Not inserted
JP17	When inserted, the AD74413R GPO_B pin can be configured to enable the digital output circuit on Channel B. It is important that this jumper is not inserted if the digital output circuit is not in use.	Not inserted
JP18	When inserted, the AD74413R GPO_C pin can be configured to enable the digital output circuit on Channel C. It is important that this jumper is not inserted if the digital output circuit is not in use.	Not inserted
JP19	When inserted, the AD74413R GPO_D pin can be configured to enable the digital output circuit on Channel D. It is important that this jumper is not inserted if the digital output circuit is not in use.	Not inserted
P6	Used to connect or to bypass the optional P-channel field effect transistor (PFET) for low resistive loads on the AD74413R Channel A. Connect Pin 1 to Pin 2, Pin 3 to Pin 4, and Pin 5 to Pin 6 to include the external PFET in the Channel A circuit. Connect Pin 1 to Pin 3 to bypass the external PFET.	PFET connected
P12	Used to connect or to bypass the optional PFET for low resistive loads on the AD74413R Channel B. Connect Pin 1 to Pin 2, Pin 3 to Pin 4, and Pin 5 to Pin 6 to include the external PFET in the Channel B circuit. Connect Pin 1 to Pin 3 to bypass the external PFET.	PFET connected
P13	Used to connect or to bypass the optional PFET for low resistive loads on the AD74413R Channel C. Connect Pin 1 to Pin 2, Pin 3 to Pin 4, and Pin 5 to Pin 6 to include the external PFET in the Channel C circuit. Connect Pin 1 to Pin 3 to bypass the external PFET.	PFET connected
P22	Used to connect or to bypass the optional PFET for low resistive loads on the AD74413R Channel D. Connect Pin 1 to Pin 2, Pin 3 to Pin 4, and Pin 5 to Pin 6 to include the external PFET in the Channel D circuit. Connect Pin 1 to Pin 3 to bypass the external PFET.	PFET connected

SOFTWARE QUICK START PROCEDURES

ACCESSING THE AD74413R EVALUATION SOFTWARE GRAPHICAL USER INTERFACE (GUI)

Use the AD74413R evaluation software to communicate with the EV-AD74413RSDZ. To download the software executable, go to www.analog.com/AD74413R.

CONFIGURING THE EV-AD74413RSDZ

To set up the EV-AD74413RSDZ, take the following steps:

1. Connect a USB cable between the PC and the SDP-S.
2. Connect the SDP-S to the EV-AD74413RSDZ through the provided evaluation board header (P21). The PC then recognizes the EV-AD74413RSDZ.
3. Power up the EV-AD74413RSDZ with the relevant power supplies as described in the Power Supplies section.
4. Download the AD74413R evaluation software executable, AD7441xR_Eval_setup.exe file, which can require a restart. After the file is installed, click the software icon to open the GUI.
5. The GUI displays a green indicator (indicated by the arrow in Figure 3) that confirms if the AD74413R is connected.
6. Click the START button to begin configuring the AD74413R (see Figure 3). The bottom of the GUI lists the tabs covered in the following sections.

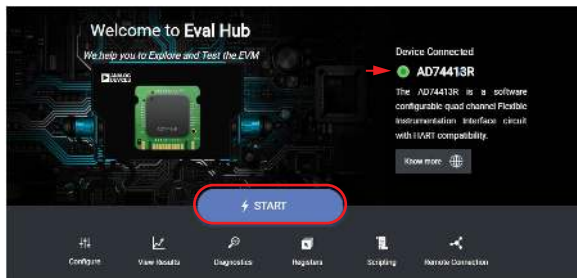

Figure 3. AD74413R Evaluation Software Start Page

USING THE SOFTWARE FOR TESTING

Configure Tab

The **Configure** tab configures the four channels of the AD74413R. Each channel can be configured as described in the AD74413R data sheet. Use the dropdown menus to configure the required use case (see Figure 4).

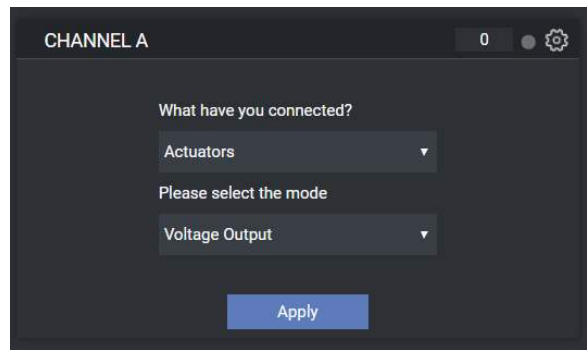

Figure 4. Channel Use Case View

After selecting the use case, the corresponding advanced settings are displayed in the channel window (see Figure 5). The gear icon in the top right corner allows the user to toggle between the main settings and the advanced settings.

Click **Apply** to update the device with the selected settings (see Figure 5).

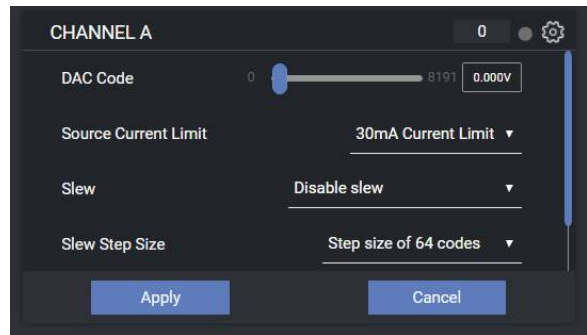

Figure 5. Channel Use Case Advanced Settings

View Results Tab

After applying the channel configuration, click the **View Results** tab to see the channel monitor. Results from each channel are shown in a separate graph (see Figure 6).

Diagnostics Tab

In the **Diagnostics** tab, click any of the test points shown in the evaluation board representation in Figure 7 to enable measurements of the required diagnostics. Up to four diagnostics can be simultaneously enabled by clicking on the available test points in the evaluation board representation.



Figure 6. View Results Tab

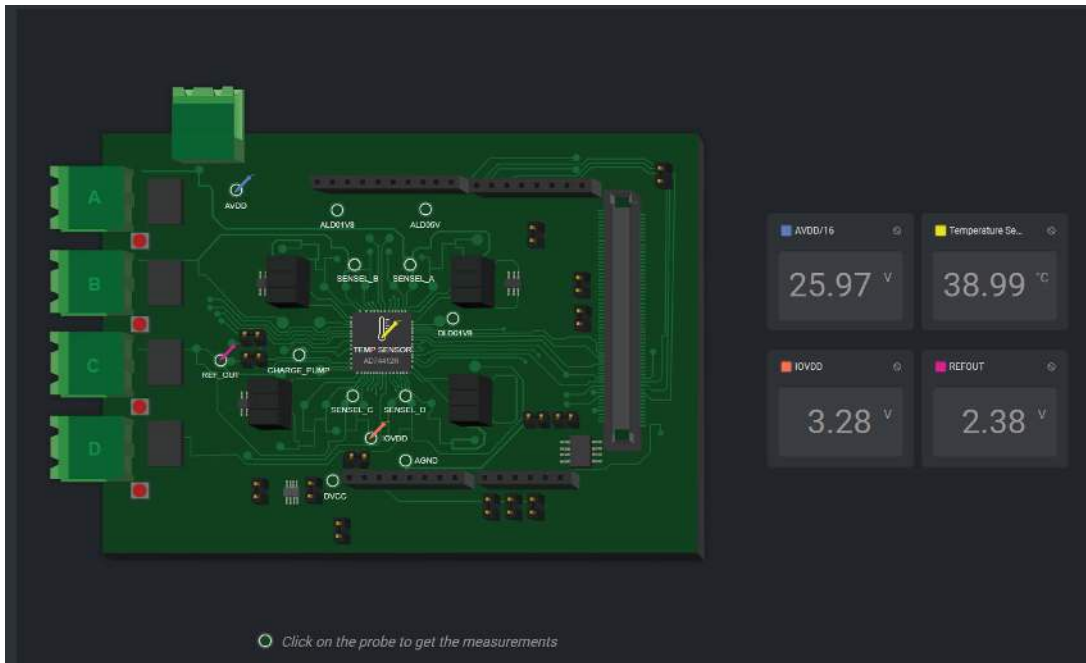

Figure 7. Diagnostics Tab

Register Map

To get to the register map, which is used to interface with the [AD74413R](#), navigate to the **Registers** tab (see Figure 9).

Two operation modes are available in the **Registers** tab, **Immediate Mode** and **Deferred Mode**, and these modes are located to the right of the **Search register** field. Click the corresponding radio button to select each mode.

Immediate mode executes register writes as soon as the bit fields are changed.

In deferred mode, no register edits are applied to the [AD74413R](#) until the **Write Register** button is clicked. Click the **Read Register** button in deferred mode to manually read from the [AD74413R](#) device (see Figure 9).

Any changes made on the register map are automatically reflected in the **Configure** tab. Click **Apply** in the **Configure** tab shown in Figure 4 and Figure 5 to display results in the **View Results** tab (see Figure 6).

Scripting Tab

The scripting tool programs, executes, and saves simple scripts. When a script is written in the left **Editor** panel in Figure 10, click the **Run** icon in the same panel (see Figure 8) to execute the writes to the [AD74413R](#). The right **Status** panel in Figure 10 displays results from any readbacks executed in the script. The commands supported by the scripting tool are limited to write, read, delay, and for loop operations shown in Figure 10. The scripting feature has autocomplete enabled by default and validates the written syntax of the script. The user can save and load configurations using the save and file open buttons, the two icons to the right of the **Auto Enable** checkbox (see Figure 10).



Figure 8. Run Icon

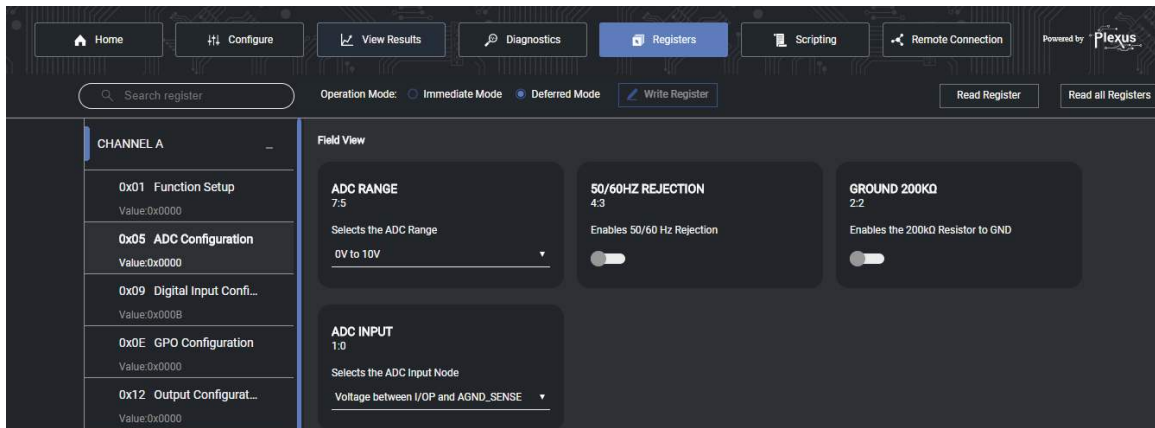

Figure 9. Register Map Display

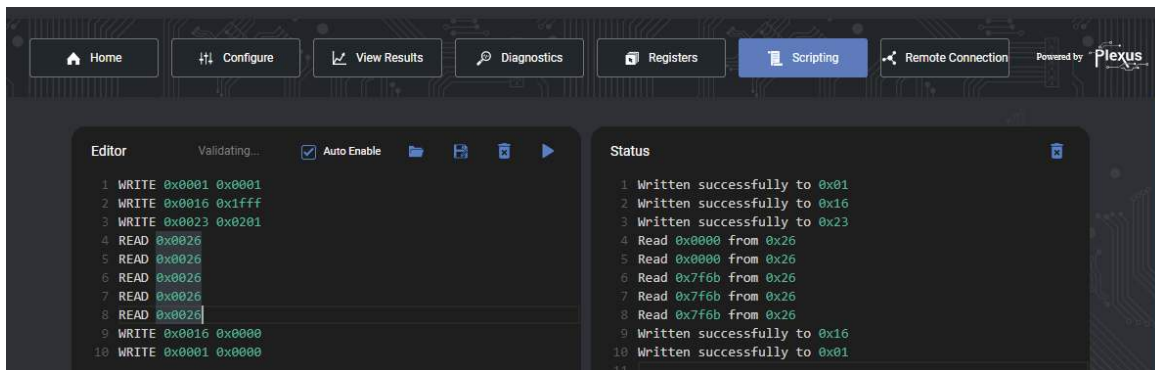

Figure 10. Scripting Page Display

EXAMPLE SEQUENCE

This section provides an example showing how to configure the AD74413R for a selected function. Consult the AD74413R data sheet when programming the AD74413R.

Force Voltage Measure Current Example

In this example, the AD74413R is configured in voltage output mode and sources 11 V across the Channel A screw terminals with the CH_A connector. This example also shows how to measure the corresponding current through the sense resistor (R_{SENSE}) using the on-chip, analog-to-digital converter (ADC). The ADC measurement is completed using a conversion rate of 20 SPS with 50 Hz and 60 Hz rejection enabled. See Table 2 for the full list of commands.

Place a suitable load across the Channel A screw terminals by using the CH_A connector. Refer to the AD74413R data sheet for the recommended load range in voltage output mode.

To complete the register write steps shown in Table 2 with the AD74413R software GUI, take the following steps:

1. In the **Configure** tab, use the dropdown menus to select **Actuators** and **Voltage Output** (see Figure 4).
2. In the advanced settings window (see Figure 5), set the **DAC Code** slider to 8191 (11 V).
3. Click **Apply**. Clicking this executes all writes required to configure the device and to enable ADC conversions in default mode. This configuration allows the AD74413R to measure voltage across R_{SENSE} in the 0 V to 2.5 V range at a 20 SPS conversion rate.
4. Click the **View Results** tab to view the ADC results.

See Figure 10 for a script example that executes the AD74413R commands described in Table 2.

Table 2. Force Voltage Measure Current Command List

Instruction	Instruction Description	W/R ¹	Register Name and Address	Data	Notes
1	Configures Channel A in voltage output mode	W	CH_FUNC_SETUPA, Register Address 0x01	0x0001	
2	Writes full-scale code to DAC_CODEA to generate 11 V	W	DAC_CODEA, Register Address 0x16	0x1FFFF	LDAC pin voltage = 0 V to update outputs instantly.
3	Measures 11 V across the Channel A screw terminals	N/A ²	N/A ²	N/A ²	Use handheld meter to measure across Test Point I/OP_A and Test Point I/ON_A to verify the voltage on Channel A.
4	Enables ADC to convert and measure current through R _{SENSE}	W	ADC_CONV_CTRL, Register Address 0x23	0x0201	When the write in Instruction 1 executes, the ADC automatically configures to measure voltage across R _{SENSE} in a 0 V to 2.5 V range.
5	Reads ADC results	R	ADC_RESULTA, Register Address 0x26		
6	Calculates current through R _{SENSE} using the equation available in the AD74413R data sheet	N/A ²	N/A ²	N/A ²	$I_{RSENSE} = \frac{V_{MIN} + \left(\left(\frac{ADC_CODE}{65,535} \right) \times Voltage\ Range \right)}{R_{SENSE}}$ <p>where: I_{RSENSE} is the current through R_{SENSE}. V_{MIN} is the minimum voltage of the selected ADC range, which is -2.5 V by default. ADC_CODE is the value of the ADC_RESULTx registers. Voltage Range is the full range of the ADC range, which is 5 V. R_{SENSE} is the sense resistor, which is 100 Ω.</p>
7	Stops ADC conversions	W	ADC_CONV_CTRL, Register Address 0x23	0x0000	
8	Programs DAC_CODEA to zero scale	W	DAC_CODEA, Register Address 0x16	0x0000	Users are recommended to clean up the DAC code and channel configuration before reprogramming the device.
9	Resets Channel A to high-Z mode	W	CH_FUNC_SETUPA, Register Address 0x01	0x0000	

¹ W stands for write and R stands for read.
² N/A is not applicable.

DISCRETE DIGITAL OUTPUT CIRCUITS

The EV-AD74413RSDZ evaluation board has four digital output circuits that are adjacent to the channel screw terminals. The circuits are an example of how the [ADM1270](#) hot swap controller can implement a digital output circuit with the [AD74413R](#).

Table 1 describes the required jumper connections for digital output operation.

Figure 14 shows the schematic for the digital output circuits. The circuits use the [ADM1270](#) and are powered from the AVDD supply.

The current limit is set by the 100 m Ω sense resistor and the voltage at the ISET pin. Connecting the ISET pin directly to the VCAP pin sets the circuit current limit to 500 mA. The current limit is adjusted by either changing the value of the sense resistor or by applying a voltage to the ISET pin using a voltage divider to the VCAP pin. Consult the [ADM1270](#) data sheet when using the digital output circuit.

When the [ADM1270](#) is enabled with the [AD74413R](#) GPO_x pin, the [ADM1270](#) controls the gate voltage of the external FET FDMC86139P while monitoring the voltage across a 100 m Ω sense resistor.

The current through the external FET is passed to the channel screw terminal, I/OP_x. The [ADM1270](#) turns off the FET after a short delay when an overcurrent fault is detected. The capacitor on the TIMER pin sets the current limit time to approximately 66 μ s.

The automatic retry function allows the [ADM1270](#) to turn on the FET after detecting an overcurrent. The capacitor on the TIMER_OFF pin generates a delay before automatically trying to turn the FET on. The automatic retry function is only activated if the 0 Ω links (JP17, JP10, JP20 and JP22) are in place. The capacitor on the TIMER_OFF pin sets the fault current limit off time to approximately 100 ms.

Undervoltage and overvoltage monitors are also available on the digital output circuit and are set to approximately 14 V and 35 V, respectively, using a voltage divider configuration on the [ADM1270](#) UV and OV pins.

Any PFET selected for this circuit contribute leakages to the I/OP_x screw terminal. This leakage can affect the accuracy of other analog functions, particularly at higher temperatures (depending on the chosen PFET and leakage profile). Consider the required accuracy of the analog function when implementing this circuit.

Users must, and can, verify their specific digital output load condition is supported by carrying out load specific testing with the digital output circuit.

Using the Digital Output Circuits

To control the digital output circuits with the [AD74413R](#), insert the appropriate jumpers as defined in Table 1.

Configure the corresponding [AD74413R](#) GPO_x pin to be controlled by the GPO_DATA bit by setting the GPO_SELECT bit in the GPO_CONFIGx register to use the logic state set by the GPO_DATA bit.

Setting the GPO_SELECT bit allows the [AD74413R](#) to enable the digital output circuits. Set the GPO_DATA bit in the GPO_CONFIGx register to 1 to enable the digital output circuit and set the bit to 0 to disable the digital output circuit.

After a channel is enabled, the channel attempts to source current up to approximately 500 mA from AVDD to the associated screw terminal.

EVALUATION BOARD SCHEMATICS

22284-011

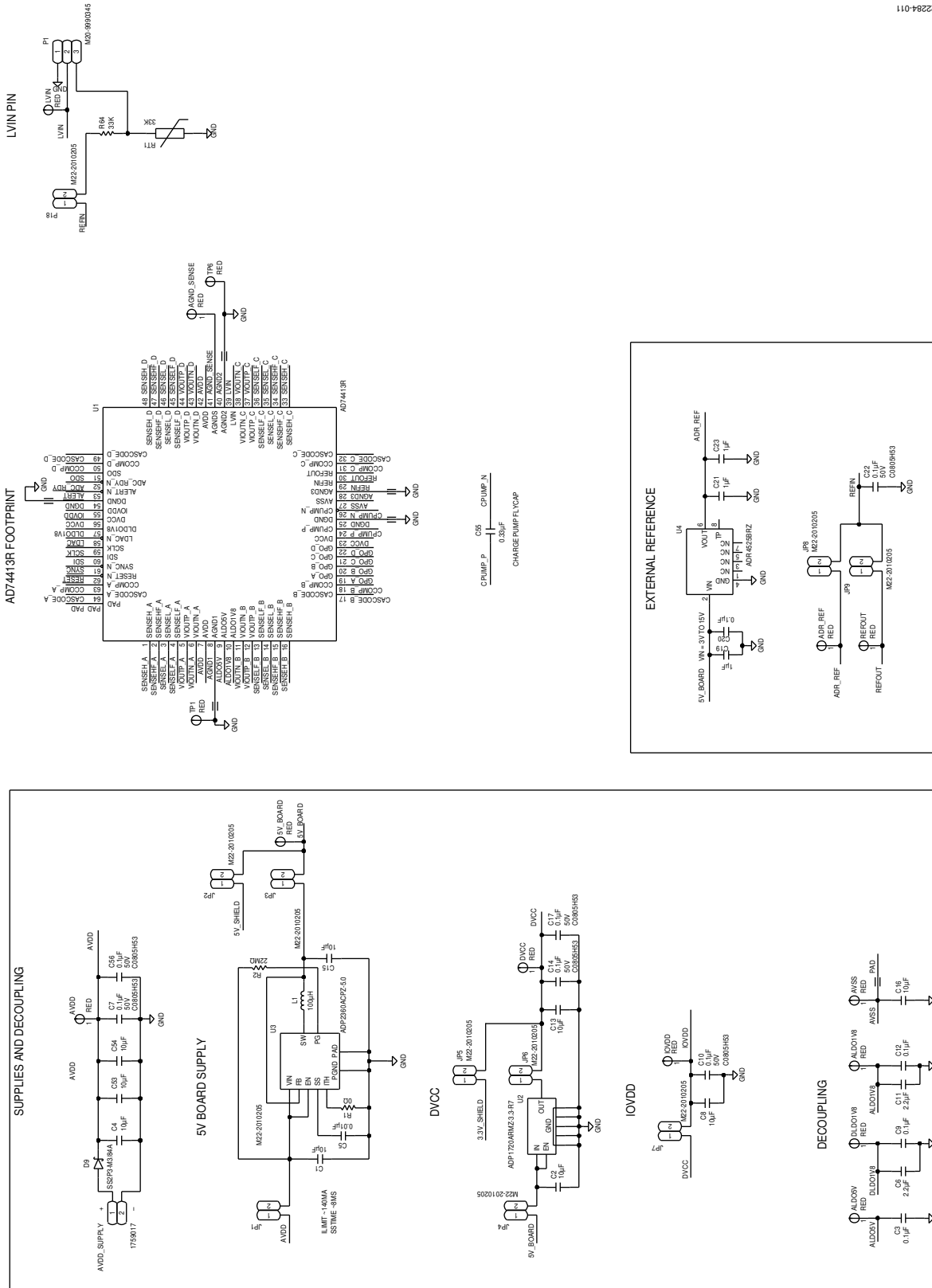

Figure 11. AD74413R, Supply and Reference Options

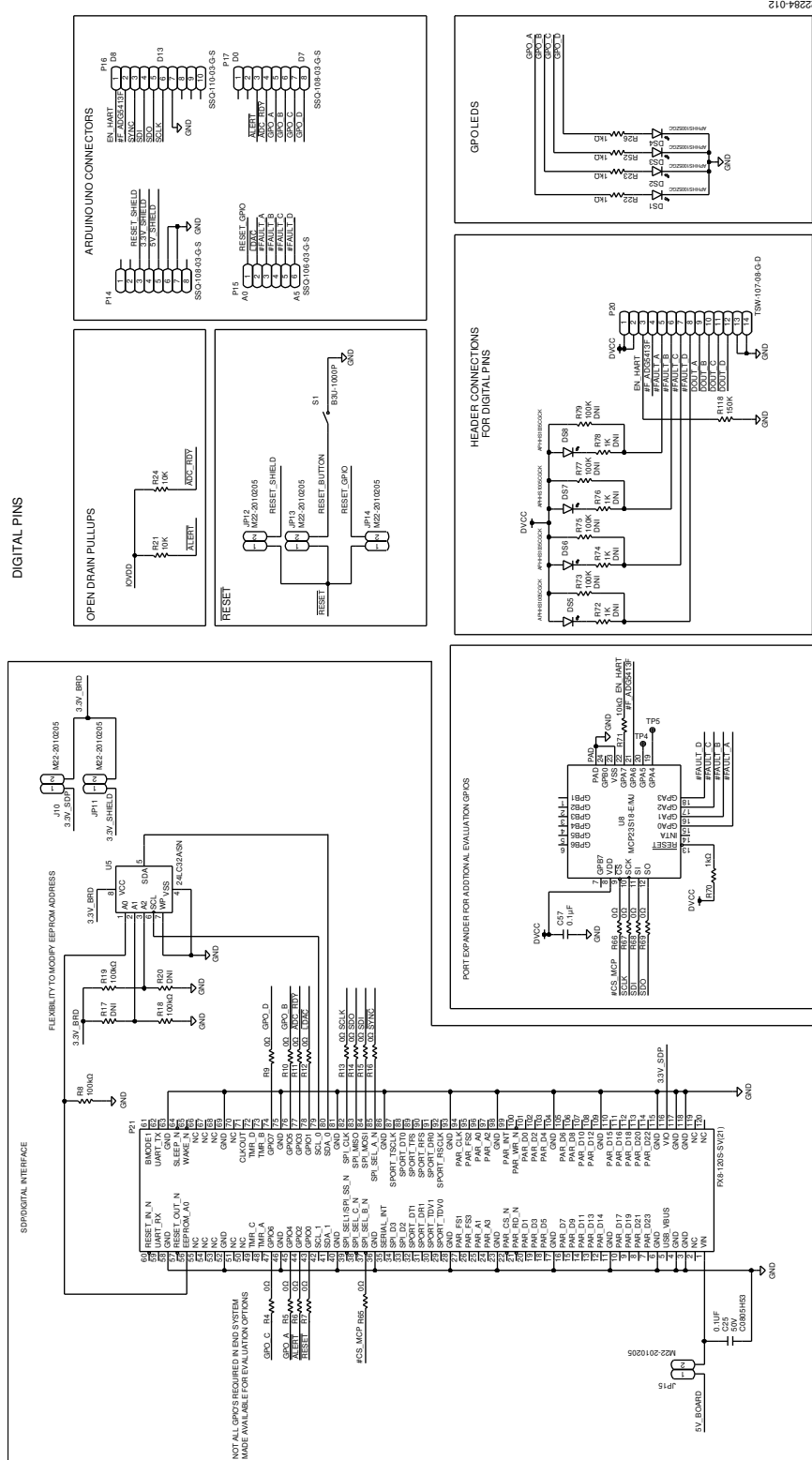

Figure 12. Digital Pins Including SDP-S Board and Arduino Board Connections

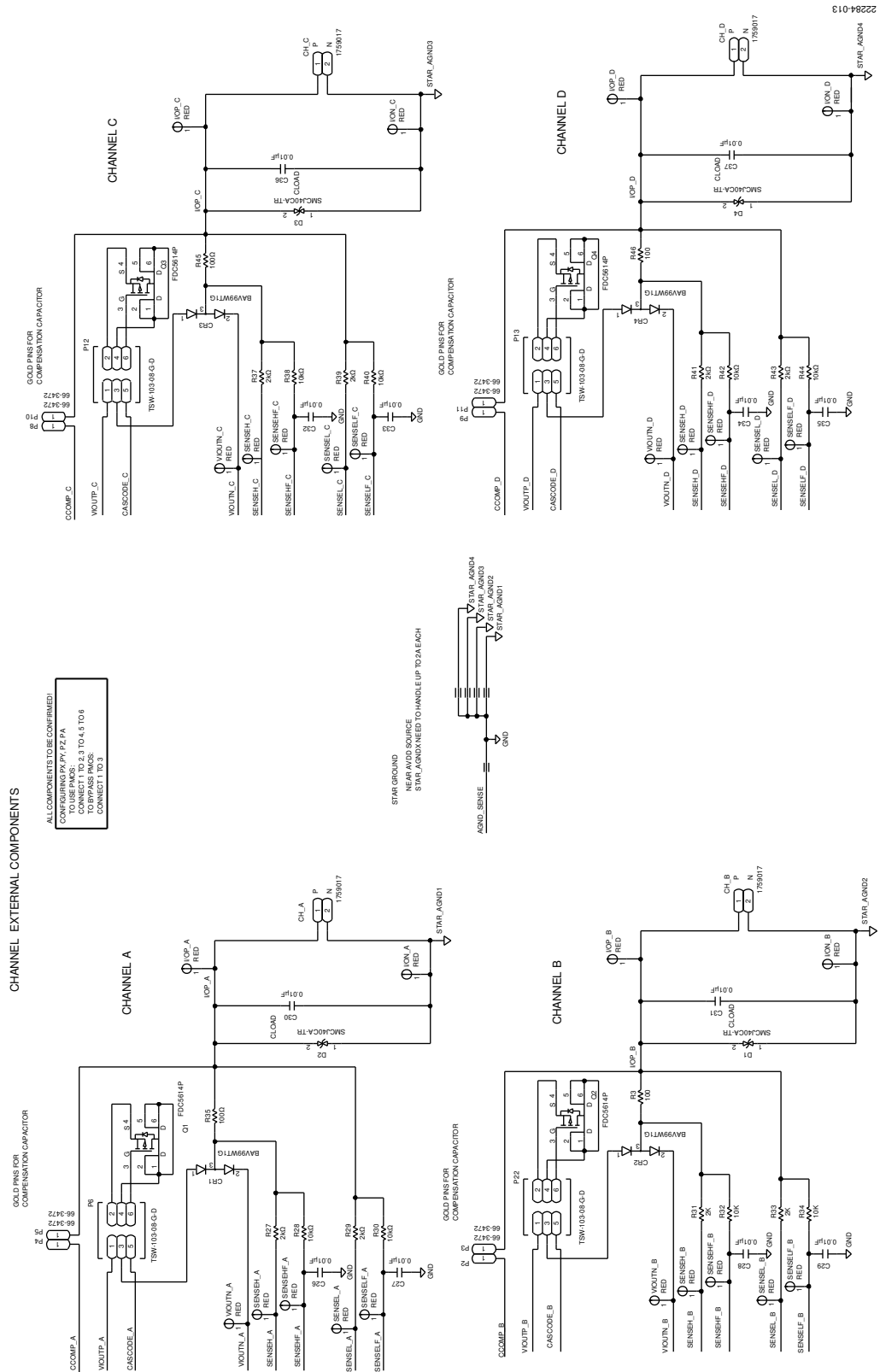

Figure 13. Channel Input and Output Circuitry Including Screw Terminals

22894-014

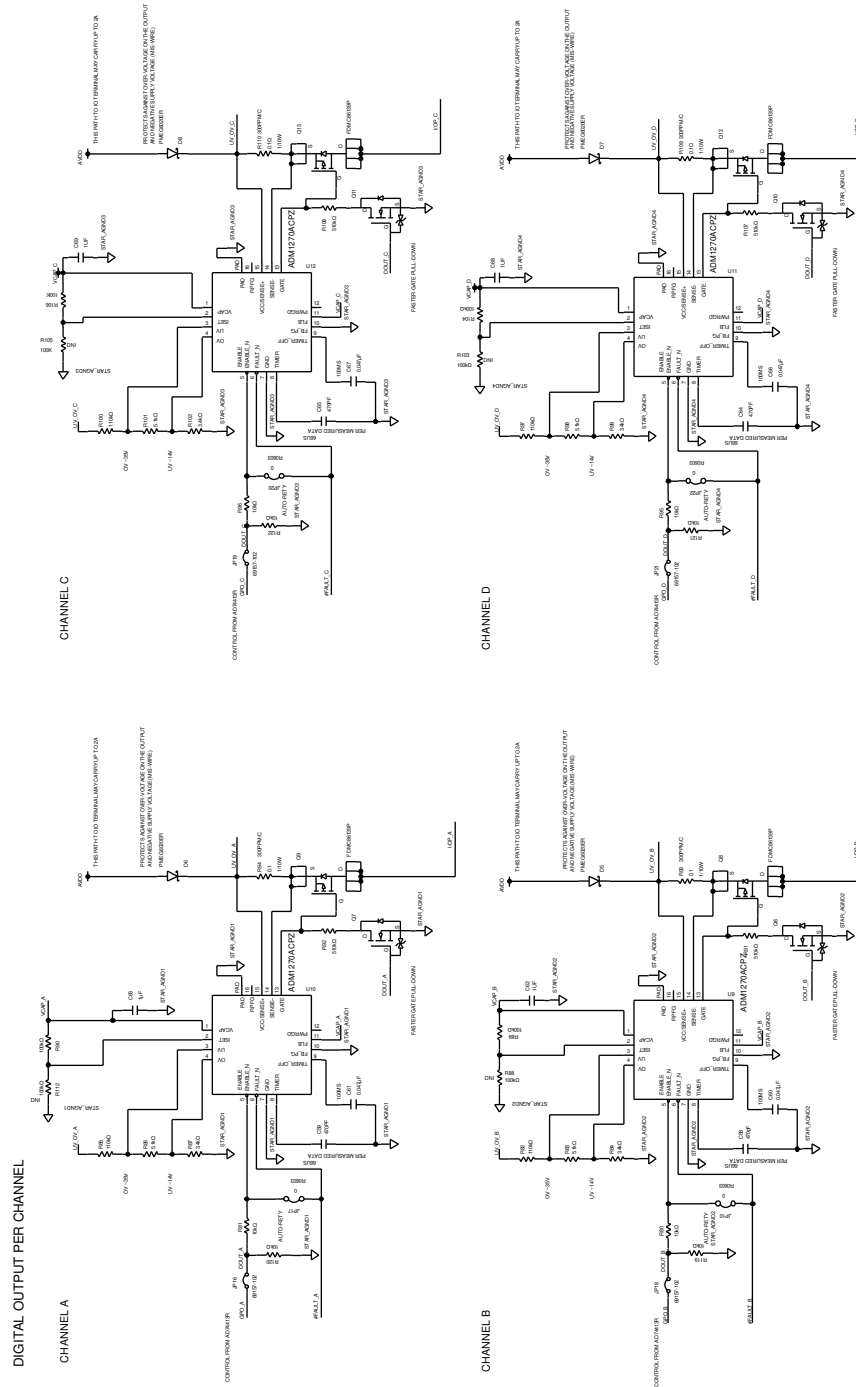

Figure 14. Digital Output Circuitry

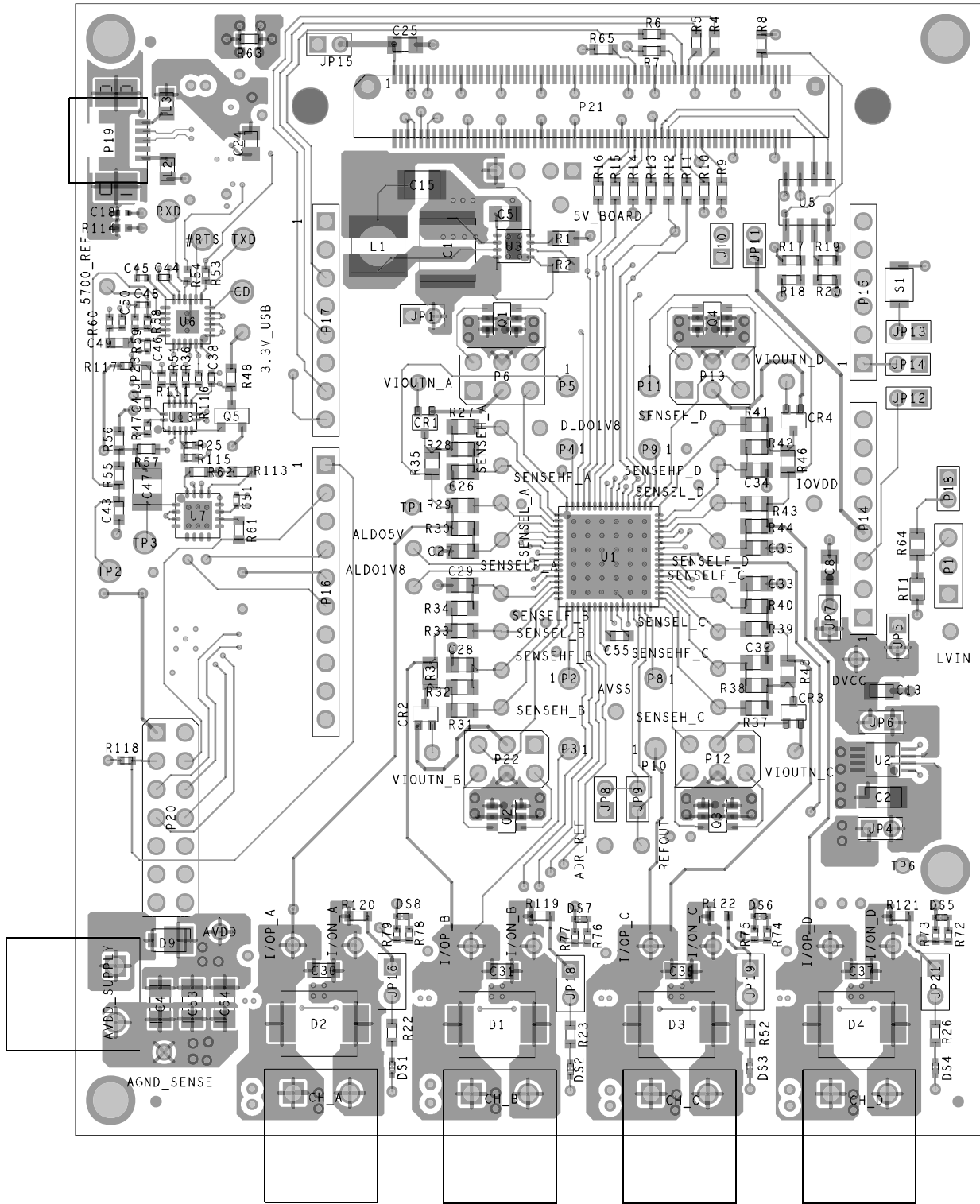
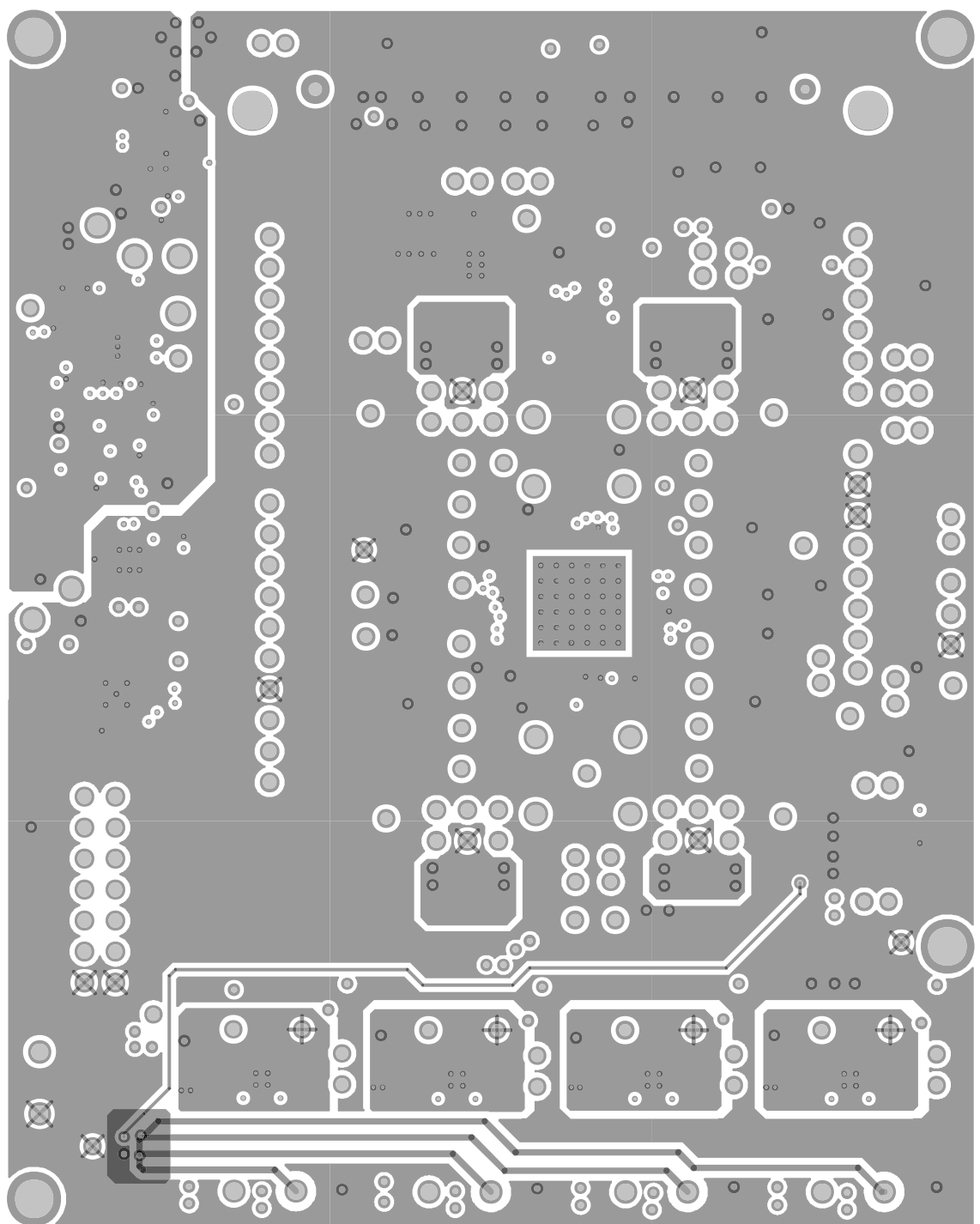

Figure 15. Layer 1, Top Layer

22284-015



22284-016

Figure 16. Layer 2, Ground Layer

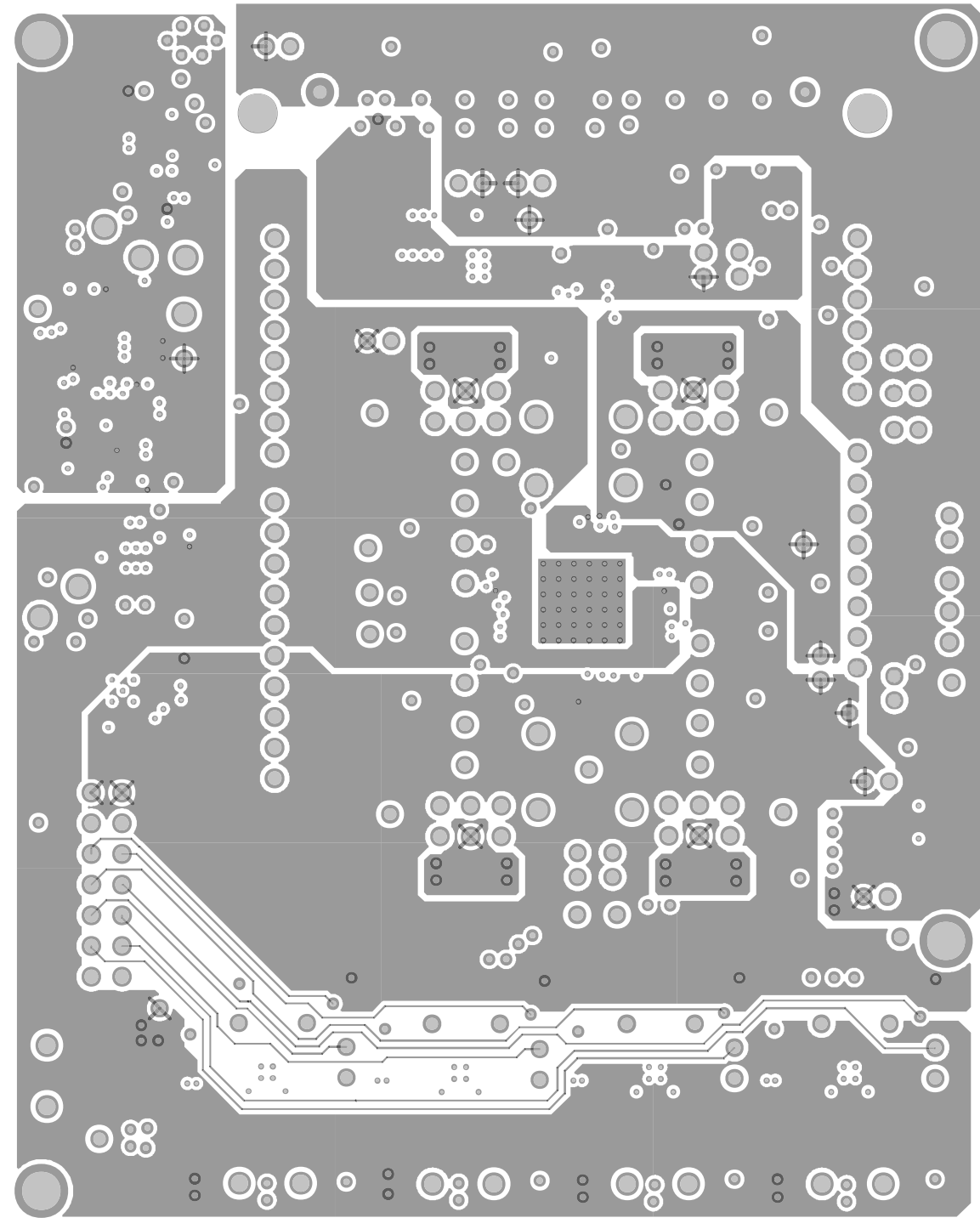

22284-017

Figure 17. Layer 3, Power Layer

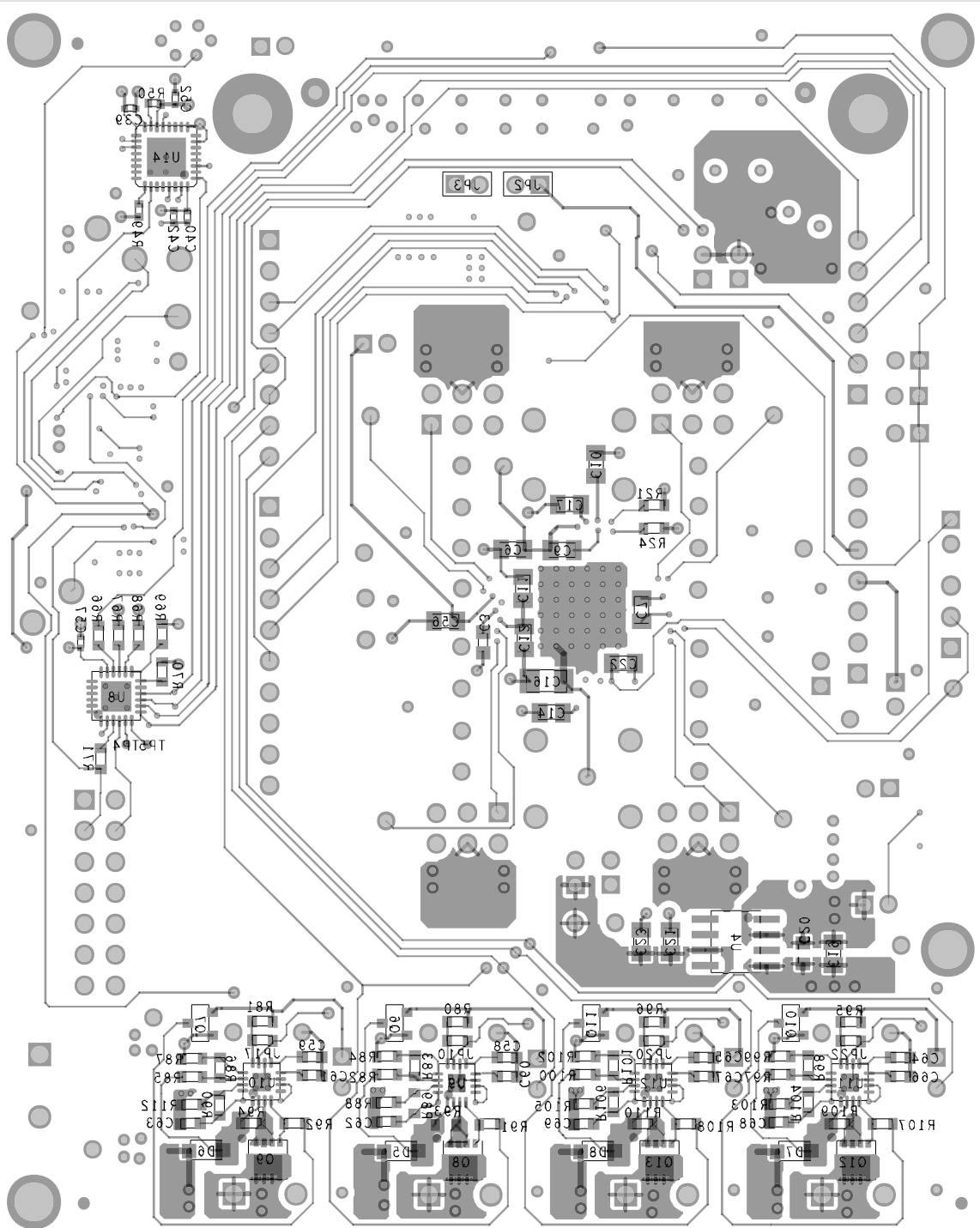

Figure 18. Layer 4, Bottom Layer

22284-018

ORDERING INFORMATION

BILL OF MATERIALS

Table 3.

Qty	Reference Designator	Description	Manufacturer	Part Number
42	5V_BOARD, ADR_REF, AGND_SENSE, ALDO1V8, ALDO5V, AVDD, AVSS, DLDO1V8, DVCC, I/ON_A, I/ON_B, I/ON_C, I/ON_D, I/OP_A, I/OP_B, I/OP_C, I/OP_D, IOVDD, LVIN, REFOUT, SENSEHF_A, SENSEHF_B, SENSEHF_C, SENSEHF_D, SENSEH_A, SENSEH_B, SENSEH_C, SENSEH_D, SENSELF_A, SENSELF_B, SENSELF_C, SENSELF_D, SENSEL_A, SENSEL_B, SENSEL_C, SENSEL_D, TP1, TP6, VIOUTN_A, VIOUTN_B, VIOUTN_C, VIOUTN_D	Red test points	Vero Technologies	20-313137
5	AVDD_SUPPLY, CH_A, CH_B, CH_C, CH_D	Printed circuit board (PCB) connectors, 2-position header	Phoenix Contact	1759017
1	C1	10 μ F capacitor	TDK	C5750X7S2A106M230KB
9	C7, C9, C10, C12, C14, C17, C22, C25, C56	0.1 μ F capacitors	AVX Corporation	08055C104K4T4A
2	C6, C11	2.2 μ F capacitors	Yageo	CC0805KKX7R6BB225
2	C8, C13	10 μ F capacitors	Murata	GRM21BR61C106KE15L
1	C15	10 μ F capacitor	Murata	GRM32ER71H106KA12L
5	C2, C4, C16, C53, C54	10 μ F capacitors	Samsung	CL31B106KBHNNNE
3	C19, C21, C23	1 μ F capacitors	Murata	GCM21BR71E105KA56L
2	C3, C20	0.1 μ F capacitors	Dielectric Labs	P62BN820MA2636
13	C5, C26 to C37	0.01 μ F capacitors	Murata	GRM2195C1H103JA01D
1	C57	0.1 μ F capacitor	TDK	CGA2B3X7R1H104K050BB
1	C55	0.33 μ F capacitor	Samsung	CL10B334K08NNNC
4	C58, C59, C64, C65	470 pF capacitors	Phycomp (Yageo)	2238 867 15471
4	C60, C61, C66, C67	0.047 μ F capacitors	TDK	CGJ3E2X7R1H473K080AA
4	C62, C63, C68, C69	1 μ F capacitors	Kemet	C0603C105K8RACTU
4	CR1 to CR4	Screw terminal isolation diodes	ON Semiconductor	BAV99WT1G
4	D1 to D4	Transient voltage suppressors (TVSs)	ST Microelectronics	SMCJ40CA-TR
4	D5 to D8	Schottky diodes	Nexperia	PMEG6020ER
1	D9	Schottky diode	Vishay	SS2P3-M3/84A
4	DS1 to DS4	Green light emitting diodes (LEDs)	Kingbright	APHHS1005ZGC
4	DS5 to DS8	Green light emitting diodes (LEDs)	Kingbright	APHHS1005CGCK
16	J10, JP1 to JP9, JP11 to JP15, P18	2-pin jumpers	Harwin	M22-2010205
4	JP10, JP17, JP20, JP22	0 Ω jumpers	Panasonic	ERJ-3GEY0R00V
4	JP16, JP18, JP19, JP21	2-pin jumpers	Amphenol FCI	69157-102
1	L1	100 μ H inductor	Würth Elektronik Group	744043101
1	P1	120-pin connector	Harwin	M20-9990345
8	P2 to P5, P8 to P11	Pin sockets	Vero Technologies	66-3472
4	P6, P12, P13, P22	6-pin jumpers	Samtec	TSW-103-08-G-D
2	P14, P17	8-pin connectors	Samtec	SSQ-108-03-G-S
1	P15	6-pin connector	Samtec	SSQ-106-03-G-S
1	P16	10-pin connector	Samtec	SSQ-110-03-G-S
1	P20	14-pin header	Samtec	TSW-107-08-G-D
1	P21	120-pin connector	HRS	FX8-1205-SV(21)

Qty	Reference Designator	Description	Manufacturer	Part Number
4	Q1 to Q4	Power metal-oxide semiconductor field effect transistors (MOSFETs)	Fairchild Semiconductor	FDC5614P
4	Q6, Q7, Q10, Q11	N-channel MOSFETs	Vishay	2N7002K-T1-E3
4	Q8, Q9, Q12, Q13	P-channel MOSFETs	ON Semiconductor	FDMC86139P
1	R1	0 Ω resistor	Panasonic	ERJ-6GEY0R00V
17	R4 to R7, R9 to R16, R65 to R69	0 Ω resistors	Multicomp (SPC)	MC0603WG00000T5E-TC
4	R82, R85, R97, R100	110 k Ω resistors	Rohm	MCR03EZPFX1103
4	R83, R86, R98, R101	5.1 k Ω resistors	Bourns	CR0603-FX-5101ELF
4	R84, R87, R99, R102	3.4 k Ω resistors	Panasonic	ERJ-3EKF3401V
4	R89, R90, R104, R106	100 k Ω resistors	Panasonic	ERJ-3EKF1003V
4	R91, R92, R107, R108	510 k Ω resistors	Yageo	RC0603FR-07510KL
4	R93, R94, R109, R110	0.1 Ω resistors	Panasonic	ERJ-3RSFR10V
1	R118	150 k Ω resistor	Panasonic	ERJ-2RKF1503X
11	R21, R24, R71, R80, R81, R95, R96, R119, R120 to R122	10 k Ω resistors	Panasonic	ERJ-3EKF1002V
3	R8, R18, R19	100 k Ω resistors	Multicomp (SPC)	MC 0.063W 0603 1% 100K
1	R2	22 M Ω resistor	Stackpole Electronics, Inc.	RMCF 1/10 22M 5% R
5	R22, R23, R26, R52, R70	1 k Ω resistors	Panasonic	ERJ-3EKF1001V
4	R27, R31, R37, R41	2 k Ω resistors	TE Connectivity	RN73C2A2K0BTG
8	R28, R30, R32, R34, R38, R40, R42, R44	10 k Ω resistors	Panasonic	ERJ-6ENF1002V
4	R29, R33, R39, R43	2 k Ω resistors	Panasonic	ERJ-6ENF2001V
4	R3, R35, R45, R46	100 Ω resistors	Yageo	RT0805BRB07100RL
1	R64	33 k Ω resistor	Panasonic	ERA-6AEB333V
1	RT1	33 k Ω thermistor	Vishay	NTCS0805E3333JHT
1	S1	Switch	Omron	B3U-1000P
1	U1	Software configurable input/output	Analog Devices	AD74413R
4	U9, U10, U11, U12	Hot swap controller	Analog Devices	ADM1270ACPZ-R7
1	U2	3.3 V regulator	Analog Devices	ADP1720ARMZ-3.3-R7
1	U3	Buck regulator	Analog Devices	ADP2360ACPZ-5.0-R7
1	U4	External reference	Analog Devices	ADR4525BRZ
1	U5	I ² C serial electrically erasable programmable read-only memory (EEPROM)	Microchip Technology	24LC32A/SN
1	U8	16-bit input/output expander	Microchip Technology	MCP23S18-E/MJ
5	Not applicable	Terminal plug	Phoenix Contact	1757019
15	Not applicable	2 mm black jumpers	Samtec	25N-BK-G
18	Not applicable	2.54 mm black jumpers	Sullins	QPC02SXGN-RC

NOTES

I²C refers to a communications protocol originally developed by Philips Semiconductors (now NXP Semiconductors).



ESD Caution

ESD (electrostatic discharge) sensitive device. Charged devices and circuit boards can discharge without detection. Although this product features patented or proprietary protection circuitry, damage may occur on devices subjected to high energy ESD. Therefore, proper ESD precautions should be taken to avoid performance degradation or loss of functionality.

Legal Terms and Conditions

By using the evaluation board discussed herein (together with any tools, components documentation or support materials, the "Evaluation Board"), you are agreeing to be bound by the terms and conditions set forth below ("Agreement") unless you have purchased the Evaluation Board, in which case the Analog Devices Standard Terms and Conditions of Sale shall govern. Do not use the Evaluation Board until you have read and agreed to the Agreement. Your use of the Evaluation Board shall signify your acceptance of the Agreement. This Agreement is made by and between you ("Customer") and Analog Devices, Inc. ("ADI"), with its principal place of business at One Technology Way, Norwood, MA 02062, USA. Subject to the terms and conditions of the Agreement, ADI hereby grants to Customer a free, limited, personal, temporary, non-exclusive, non-sublicensable, non-transferable license to use the Evaluation Board FOR EVALUATION PURPOSES ONLY. Customer understands and agrees that the Evaluation Board is provided for the sole and exclusive purpose referenced above, and agrees not to use the Evaluation Board for any other purpose. Furthermore, the license granted is expressly made subject to the following additional limitations: Customer shall not (i) rent, lease, display, sell, transfer, assign, sublicense, or distribute the Evaluation Board; and (ii) permit any Third Party to access the Evaluation Board. As used herein, the term "Third Party" includes any entity other than ADI, Customer, their employees, affiliates and in-house consultants. The Evaluation Board is NOT sold to Customer; all rights not expressly granted herein, including ownership of the Evaluation Board, are reserved by ADI. CONFIDENTIALITY. This Agreement and the Evaluation Board shall all be considered the confidential and proprietary information of ADI. Customer may not disclose or transfer any portion of the Evaluation Board to any other party for any reason. Upon discontinuation of use of the Evaluation Board or termination of this Agreement, Customer agrees to promptly return the Evaluation Board to ADI. ADDITIONAL RESTRICTIONS. Customer may not disassemble, decompile or reverse engineer chips on the Evaluation Board. Customer shall inform ADI of any occurred damages or any modifications or alterations it makes to the Evaluation Board, including but not limited to soldering or any other activity that affects the material content of the Evaluation Board. Modifications to the Evaluation Board must comply with applicable law, including but not limited to the RoHS Directive. TERMINATION. ADI may terminate this Agreement at any time upon giving written notice to Customer. Customer agrees to return to ADI the Evaluation Board at that time. LIMITATION OF LIABILITY. THE EVALUATION BOARD PROVIDED HEREUNDER IS PROVIDED "AS IS" AND ADI MAKES NO WARRANTIES OR REPRESENTATIONS OF ANY KIND WITH RESPECT TO IT. ADI SPECIFICALLY DISCLAIMS ANY REPRESENTATIONS, ENDORSEMENTS, GUARANTEES, OR WARRANTIES, EXPRESS OR IMPLIED, RELATED TO THE EVALUATION BOARD INCLUDING, BUT NOT LIMITED TO, THE IMPLIED WARRANTY OF MERCHANTABILITY, TITLE, FITNESS FOR A PARTICULAR PURPOSE OR NON-INFRINGEMENT OF INTELLECTUAL PROPERTY RIGHTS. IN NO EVENT WILL ADI AND ITS LICENSORS BE LIABLE FOR ANY INCIDENTAL, SPECIAL, INDIRECT, OR CONSEQUENTIAL DAMAGES RESULTING FROM CUSTOMER'S POSSESSION OR USE OF THE EVALUATION BOARD, INCLUDING BUT NOT LIMITED TO LOST PROFITS, DELAY COSTS, LABOR COSTS OR LOSS OF GOODWILL. ADI'S TOTAL LIABILITY FROM ANY AND ALL CAUSES SHALL BE LIMITED TO THE AMOUNT OF ONE HUNDRED US DOLLARS (\$100.00). EXPORT. Customer agrees that it will not directly or indirectly export the Evaluation Board to another country, and that it will comply with all applicable United States federal laws and regulations relating to exports. GOVERNING LAW. This Agreement shall be governed by and construed in accordance with the substantive laws of the Commonwealth of Massachusetts (excluding conflict of law rules). Any legal action regarding this Agreement will be heard in the state or federal courts having jurisdiction in Suffolk County, Massachusetts, and Customer hereby submits to the personal jurisdiction and venue of such courts. The United Nations Convention on Contracts for the International Sale of Goods shall not apply to this Agreement and is expressly disclaimed.

©2019 Analog Devices, Inc. All rights reserved. Trademarks and registered trademarks are the property of their respective owners.
UG22284-0-11/19(0)



www.analog.com