



BR3500W - BR3510W

SILICON BRIDGE RECTIFIERS

PRV : 50 - 1000 Volts
Io : 35 Amperes

FEATURES :

- * High current capability
- * High surge current capability
- * High reliability
- * Low reverse current
- * Low forward voltage drop
- * High case dielectric strength
- * Pb / RoHS Free

MECHANICAL DATA :

- * Case : Molded plastic with heatsink integrally mounted in the bridge encapsulation
- * Epoxy : UL94V-0 rate flame retardant
- * Terminals : Plated lead solderable per MIL-STD-202, Method 208 guaranteed
- * Polarity : Polarity symbols marked on case
- * Mounting position : Bolt down on heat-sink with silicone thermal compound between bridge and mounting surface for maximum heat transfer efficiency
- * Weight : 15.95 grams

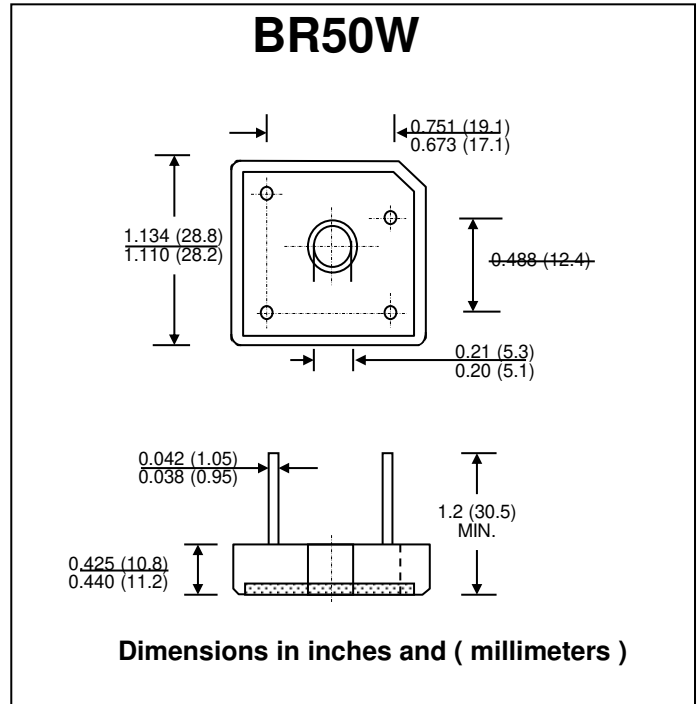

MAXIMUM RATINGS AND ELECTRICAL CHARACTERISTICS

Rating at 25 °C ambient temperature unless otherwise specified.
 Single phase, half wave, 60 Hz, resistive or inductive load.
 For capacitive load, derate current by 20%.

| RATING | SYMBOL | BR 3500W | BR 3501W | BR 3502W | BR 3504W | BR 3506W | BR 3508W | BR 3510W | UNITS | |
|--|-------------------------|---------------|----------|----------|----------|----------|----------|----------|-------|------------------|
| Maximum Recurrent Peak Reverse Voltage | V _{RRM} | 50 | 100 | 200 | 400 | 600 | 800 | 1000 | V | |
| Maximum RMS Voltage | V _{RMS} | 35 | 70 | 140 | 280 | 420 | 560 | 700 | V | |
| Maximum DC Blocking Voltage | V _{DC} | 50 | 100 | 200 | 400 | 600 | 800 | 1000 | V | |
| Maximum Average Forward Current T _c = 55°C | I _{F(AV)} | 35 | | | | | | | | A |
| Peak Forward Surge Current Single half sine wave Superimposed on rated load (JEDEC Method) | I _{FSM} | 400 | | | | | | | | A |
| Current Squared Time at t < 8.3 ms. | I ² t | 660 | | | | | | | | A ² S |
| Maximum Forward Voltage per Diode at I _F = 17.5 A | V _F | 1.1 | | | | | | | | V |
| Maximum DC Reverse Current at Rated DC Blocking Voltage | T _a = 25 °C | 10 | | | | | | | | μA |
| | T _a = 100 °C | 200 | | | | | | | | μA |
| Typical Thermal Resistance at Junction to Case (Note 1) | R _{θJC} | 1.5 | | | | | | | | °C/W |
| Typical Thermal Resistance at Junction to Ambient | R _{θJA} | 10 | | | | | | | | °C/W |
| Operating Junction Temperature Range | T _J | - 40 to + 150 | | | | | | | | °C |
| Storage Temperature Range | T _{STG} | - 40 to + 150 | | | | | | | | °C |

Note :

1. Thermal Resistance from junction to case with units mounted on a 7.5" x 3.5" x 4.6" (19cm.x 9cm.x 11.8cm.) Al.-Finned Plate



RATING AND CHARACTERISTIC CURVES (BR3500W THRU BR3510W)

FIG.1 - DERATING CURVE FOR OUTPUT RECTIFIED CURRENT

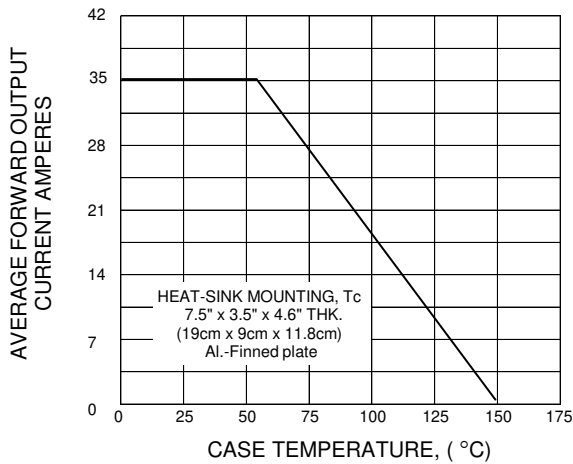

FIG.2 - MAXIMUM NON-REPETITIVE PEAK FORWARD SURGE CURRENT

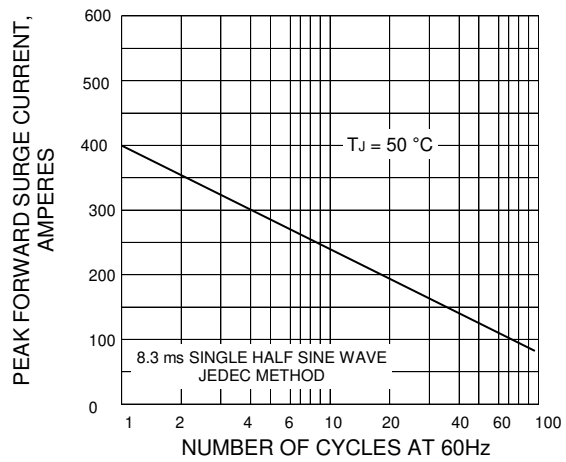

FIG.3 - TYPICAL FORWARD CHARACTERISTICS PER DIODE

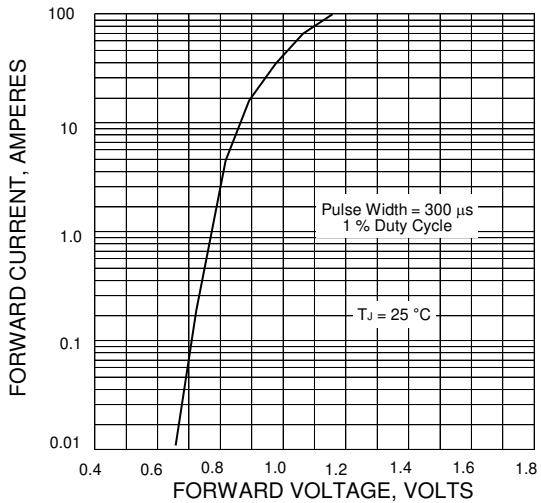

FIG.4 - TYPICAL REVERSE CHARACTERISTICS PER DIODE

