

Advanced Headless HMI with IIoT Features



- Enhanced Graphics, Animation, and Security
- Email Alarm Notification
- Recipe, Data Logging, Pie Charts
- Trend Graphics, Circular Trends
- Optional CODESYS® and OPC-UA Support
- Fanless Cooling System with Heatsink



| | | |
|-----------------------------|---|---|
| System | CPU | Quad-core RISC |
| | Memory (RAM) | 1 GB |
| | Memory (Flash) | 4 GB |
| | RTC | Built-in |
| I/O Ports | Serial | 1 x DE9P COM1: RS-232, COM2: RS-485 2 or 4 wire, COM3: RS-485 2 wires |
| | LAN | 1 x GbE RJ-45; 1 x 10/100 Base-T RJ-45 |
| | CANbus | N/A |
| | USB Host | 1 x USB 2.0 |
| | USB Client | N/A |
| | Audio | N/A |
| | Video | N/A |
| | Wi-Fi | N/A |
| | HDMI® | N/A |
| | SD Card Slot | 1x Micro Secure Digital Memory Card (SD/SDHC) Socket, 32GB Capacity |
| | Electrical | Input Voltage |
| Input Current | | 850 mA @ 24 VDC |
| Input Power | | 20.4 W |
| Power Isolation | | Built-in |
| Isolation Resistance | | Exceed 50 MΩ at 500 VDC |
| Mechanical | Enclosure | Plastic, charcoal grey |
| | PCB Coating | Yes |
| | Dimensions (W x H x D) | 1.17 x 5.11 x 4.52 inches [29.8 x 130 x 115 mm] |
| | Net Weight | Approx. 0.53 lbs. [0.24 kg] |
| | Mounting | 35 mm DIN rail |
| Environmental | Operating Temperature | 32° ~ 122°F (°0 ~ 50°C) |
| | Storage Temperature | -4° ~ 140°F (-20° ~ 60°C) |
| | Relative Humidity | 10% ~ 90% (non-condensing) |
| | Vibration Endurance | 10 to 25 Hz (X, Y, Z direction, 2G, 30 minutes) |
| | Rating | IP20 |
| | Certifications | cULus, CE, RoHS |
| Software | EBPro (v6.07.01 or later), EasyAccess 2.0 (optional), CODESYS (optional), IIoT Ready, MQTT, Sparkplug, cMT Viewer | |
| Notes | Specifications subject to change without notice | |

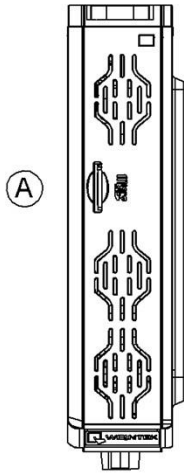

Top View

Dimensions are in inches [mm]

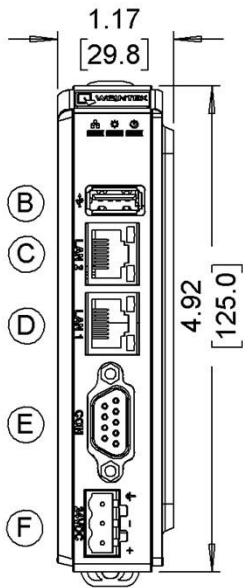

Front View

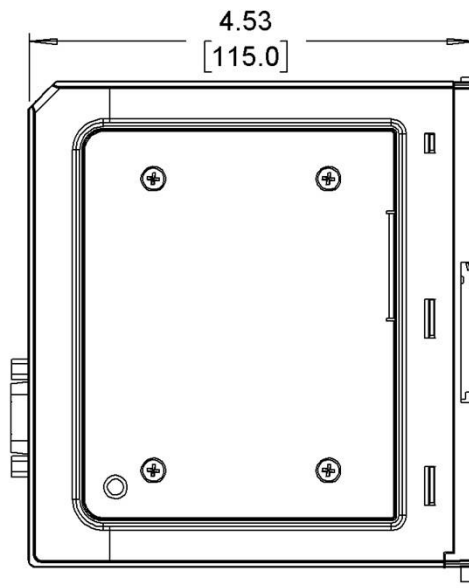

Side View

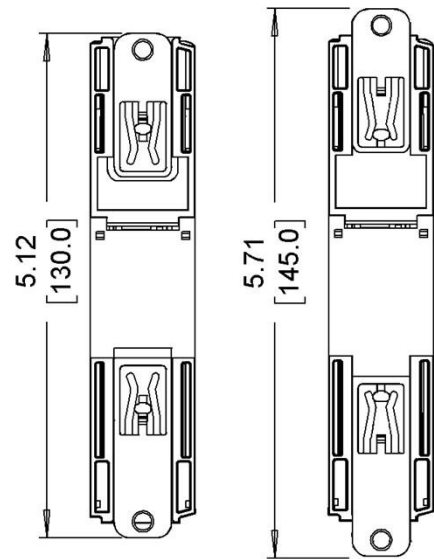

Rear View

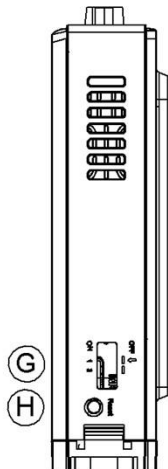

Bottom View

- | | | | |
|---|-----------------------|---|-----------------|
| A | SD/SDHC Card Slot | E | COM Port DE9P |
| B | USB 2.0 Host Port | F | Power Connector |
| C | Ethernet Port | G | DIP Switches |
| D | Gigabit Ethernet Port | H | Reset Button |

Why Buy A Maple HMI

In addition to our powerful and affordable hardware, we'll also continue to support your company long after a sale. Wide product selection, large in-stock inventory, outstanding product warranty, free technical support and software, and in-house repairs with quick turnaround times, Maple Systems has your business covered.



Add Remote IO for PLC Functionality

Select Maple Advanced and High-Performance HMIs have a sleek hardware platform that runs both an HMI application created with our free HMI software and PLC logic programmed with CODESYS; each on its own dedicated processor. Unlike the typical multicore set up, where the operating system scheduler is responsible for allocating tasks to each processor, these HMIs have a hard separation between cores. One core is dedicated to the HMI application, the other to executing PLC logic of the CODESYS project. This ensures taxing graphics processing operations will not interfere with deterministic real time control tasks executing on the other processor.

After selecting your HMI, choose from a suite of easy to use [powerful I/O modules](#) to connect to your field equipment. We offer a complete set of I/O modules which can be combined with one of our communication couplers to create a remote I/O block.

Remote Access and the IIoT

[Remote access](#) is the ability to access an HMI or connected device, from another device, at any time, and from anywhere. With our [free HMI software](#) and supported hardware solutions, you have the freedom to access the HMI, and all its data and applications, from another device and control it as if you were standing in front of it. Our Advanced and High-Performance HMIs support [cMT Viewer](#), [WebView](#), Web Streaming, and [EasyAccess 2.0](#) and are designed to make accessing your HMI and data fast and streamlined.

Let us serve as your guide, making it an easy process to join the next evolution of automated control. Our Advanced and High-Performance HMIs can act as an access point enabling operating equipment on the plant floor to connect to information technologies of the Industrial Internet of Things (IIoT). With our IIoT solutions, that are already included in the EBPro software, we can help you achieve better access to invaluable data and open a world of possibilities for your business. Read more about our [IIoT solutions](#).

Build your SCADA

We offer all the components you need to create your own unique level of supervisory data acquisition and control, from the simplest stand-alone machine to sophisticated multi-device networked production line(s), all the way to enterprise-level operations and IIoT functionalities leveraging cloud connectivity.

Our products can help you standardize communications between devices, gluing different systems together for one source to your SCADA. No need to redesign your entire application. Keep the components that are already working for you, just add Maple Systems components to grow your abilities to supervise, control, and acquire data.

Incredible Functionality Out of the Box

- Easily and quickly create the project with functional objects including numeric object, lamp object, combo-button, alarms, and recipes
- Pick and place objects, pictures, and shapes
- Import/export recipes
- Create trend display, graphs, XY plots, and pie charts
- Add passwords and security levels
- Assign communication (PLC) drivers easily and more with our Free HMI software

Additionally our HMIs support remote access solutions with VNC, MQTT, and OPC UA. For additional features see our Advanced HMI series.



User Friendly HMI Configuration Software

Because designing the layout of screens and user-interface (UI) of the HMI is typically where most of the development time is spent, we've made our Free HMI configuration software easy to use.

- Import tags feature
- Tools to diagnose and monitor PLC to HMI connection
- Debugging tools
- Pre-built libraries
- Off-line and on-line simulation

These are just a few of the ways our software makes creating your project easier. We also have controller information sheets, cable drawings, sample projects, Getting Started Guides, and videos/tutorials available in our [support center](#) 24/7.



Programmable Logic Controller (PLC) Connectivity

With over 300 PLC & Controller communication protocols, these HMIs will easily integrate with your preferred PLC brands, including:

Allen-Bradley
Siemens
Omron
Emerson
GE
Panasonic
Mitsubishi
[...and many more](#)

Allen-Bradley **ABB** babcock™

BALDOR *Danfoss* SIEMENS

MITSUBISHI **Parker**

TOSHIBA YASKAWA **Koyo**

Matsushita

Headless HMIs Feature Overview

| Standard Headless HMI | Advanced Headless HMI | High-Performance Headless HMI |
|---|---|---|
| Alarm & Event Messages | Alarm & Event Messages | Alarm & Event Messages |
| Animation - Flow Block | Animation - Flow Block | Animation - Flow Block |
| ASCII Characters | ASCII Characters | ASCII Characters |
| BACnet | BACnet | BACnet |
| Bar Graphs | Bar Graphs | Bar Graphs |
| Barcode Scanner (Android Camera) | Barcode Scanner (Android Camera) | Barcode Scanner (Android Camera) |
| cMT Diagnoser | cMT Diagnoser | cMT Diagnoser |
| cMT Viewer Support | cMT Viewer Support | cMT Viewer Support |
| Combo Button | Combo Button | Combo Button |
| Data Logging and Sampling | Data Logging and Sampling | Data Logging and Sampling |
| Database Server | Database Server | Database Server |
| Date / Time | Date / Time | Date / Time |
| Dynamic Drawing | Dynamic Drawing | Dynamic Drawing |
| Dynamic Scale | Dynamic Scale | Dynamic Scale |
| EasyAccess 2.0 | EasyAccess 2.0 | EasyAccess 2.0 |
| EasyWatch | EasyWatch | EasyWatch |
| Email | Email | Email |
| Enhanced Security Mode | Enhanced Security Mode | Enhanced Security Mode |
| Event Alarm Log | Event Alarm Log | Event Alarm Log |
| File Transfer Protocol (FTP) | File Transfer Protocol (FTP) | File Transfer Protocol (FTP) |
| Grid Display | Grid Display | Grid Display |
| Languages (Up to 24) | Languages (Up to 24) | Languages (Up to 24) |
| Libraries | Libraries | Libraries |
| Macro Windows Open / Cycle / Close | Macro Windows Open / Cycle / Close | Macro Windows Open / Cycle / Close |
| Macros | Macros | Macros |
| Meters & Gauges | Meters & Gauges | Meters & Gauges |
| Modbus | Modbus | Modbus |
| MQTT | MQTT | MQTT |
| MQTT - Advanced JSON | MQTT - Advanced JSON | MQTT - Advanced JSON |
| MQTT - AWS IoT, Sparkplug B, Azure IoT Hub, Google Cloud IoT Core | MQTT - AWS IoT, Sparkplug B, Azure IoT Hub, Google Cloud IoT Core | MQTT - AWS IoT, Sparkplug B, Azure IoT Hub, Google Cloud IoT Core |
| Objects (Grouping, Layering, Aligning, Flip) | Objects (Grouping, Layering, Aligning, Flip) | Objects (Grouping, Layering, Aligning, Flip) |
| Off-line / On-line Simulation | Off-line / On-line Simulation | Off-line / On-line Simulation |
| OPC UA Client | OPC UA Client | OPC UA Client |
| OPC UA Server | OPC UA Server | OPC UA Server |
| Operation Log | Operation Log | Operation Log |
| Pass-Through Mode | Pass-Through Mode | Pass-Through Mode |
| Picture Object | Picture Object | Picture Object |
| Pie Chart | Pie Chart | Pie Chart |
| PLC Tag Embedded in Project | PLC Tag Embedded in Project | PLC Tag Embedded in Project |
| Project Password | Project Password | Project Password |
| Recipes | Recipes | Recipes |
| Remote Access | Remote Access | Remote Access |
| Scheduler | Scheduler | Scheduler |
| Security Levels (Enhanced) | Security Levels (Enhanced) | Security Levels (Enhanced) |
| SQL Database Server Integration | SQL Database Server Integration | SQL Database Server Integration |
| String Table | String Table | String Table |
| System Setting Editor | System Setting Editor | System Setting Editor |
| Table | Table | Table |
| Text Object | Text Object | Text Object |
| Time Synchronization | Time Synchronization | Time Synchronization |
| Timer Object | Timer Object | Timer Object |
| Trend Display (Graphs) | Trend Display (Graphs) | Trend Display (Graphs) |
| USB Tethering | USB Tethering | USB Tethering |
| Utility Manager | Utility Manager | Utility Manager |
| XY Plot | XY Plot | XY Plot |
| | CODESYS | CODESYS |
| | WebView | WebView |
| | | Create a Andon/Status Display |
| | | VNC Viewer |
| | | VNC Server |
| | | User-Defined Start-Up Screen |
| | | Picture Viewer |
| | | File Browser |
| | | IP Camera |
| | | USB Camera |
| | | Media Player |
| | | PLC Web Browser |
| | | PDF Reader |
| | | Web Streaming |

This table is for illustration only and subject to change. Always check the software to see if a feature is supported in your specific hardware.