

- NOTES:
1. EACH PART SHALL BE MARKED WITH U-92A/U & M9177/3-1.
 2. PART SHALL BE ON QUALIFIED PRODUCT LIST FOR MIL-C-9177/3A.
 3. CRIMPING TOOLS USE M22520/5-01 HAND TOOL W/CRIMP DIE M22520/5-29, M22520/5-35 OR M22520/5-55.
 4. MATING CONNECTORS M9177/1-1 & M9177/2-1.

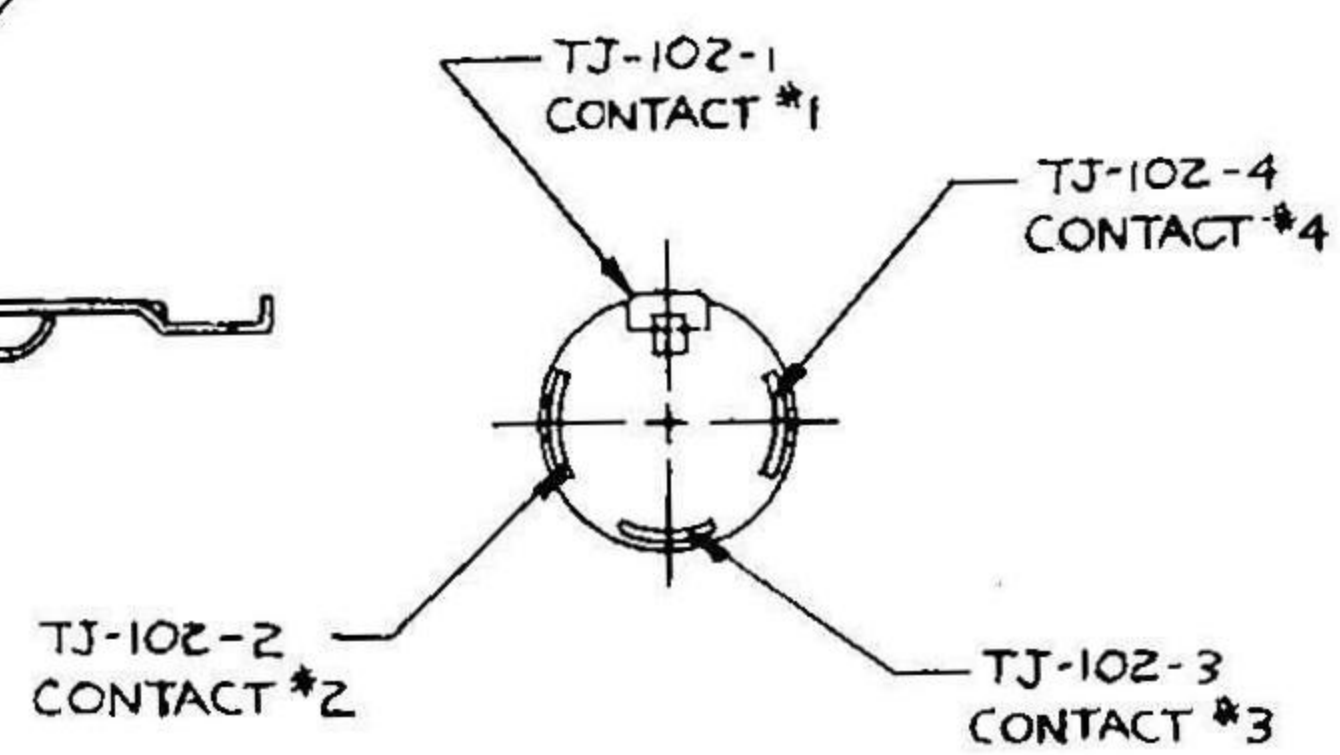

JACK ASSEMBLY TJ-102-9

.6875-24 UNEF-2A
FULL THREADS
TO WITHIN .063
OF SHOULDER

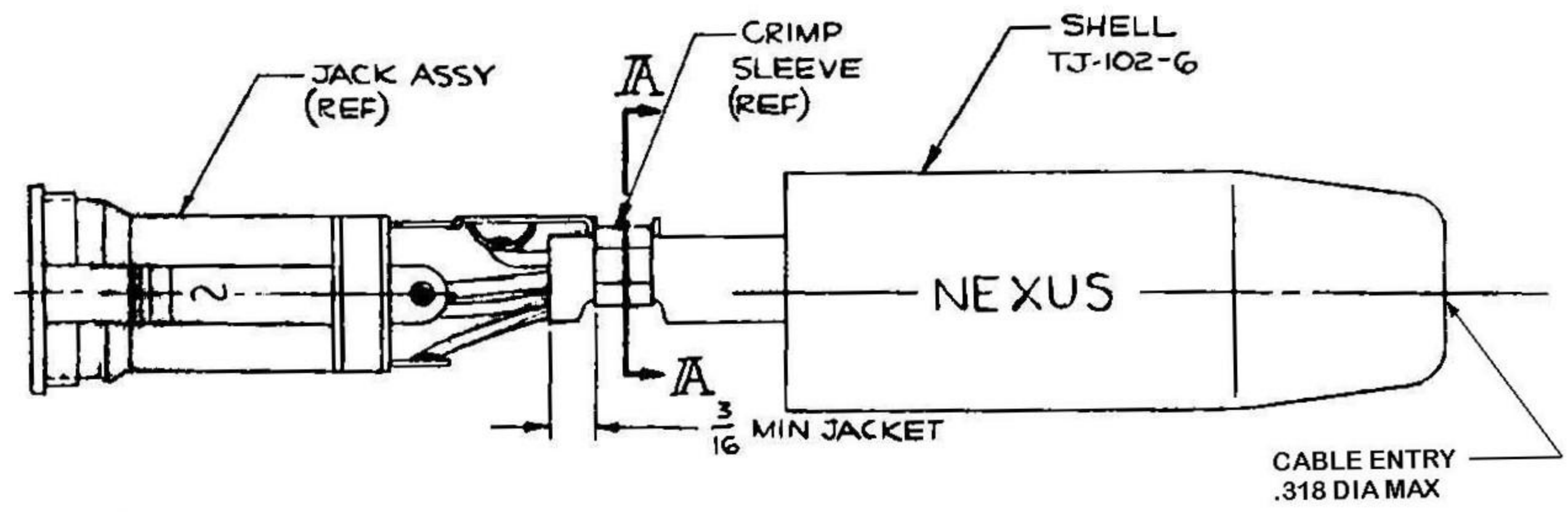

C TJ-102

CORD: WF-14/U (4 COND)
FOR USE WITH U-94A/U

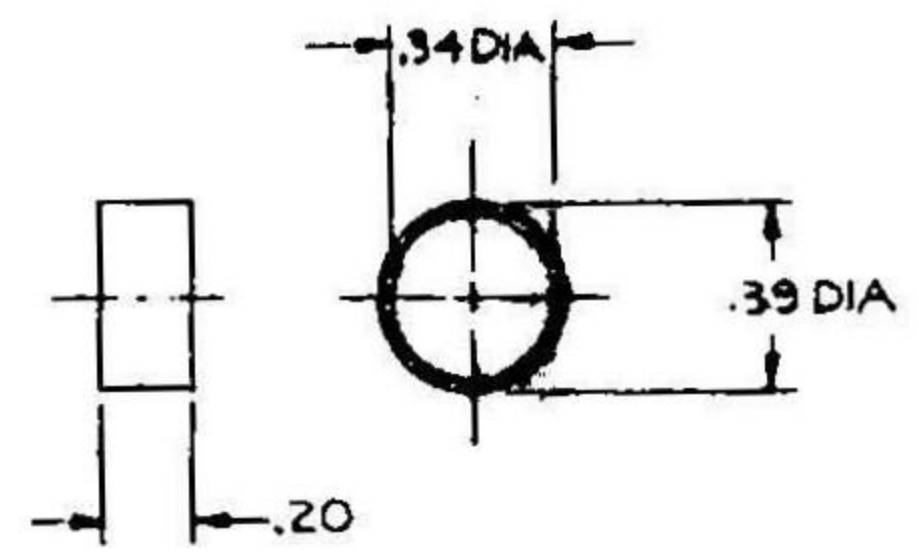
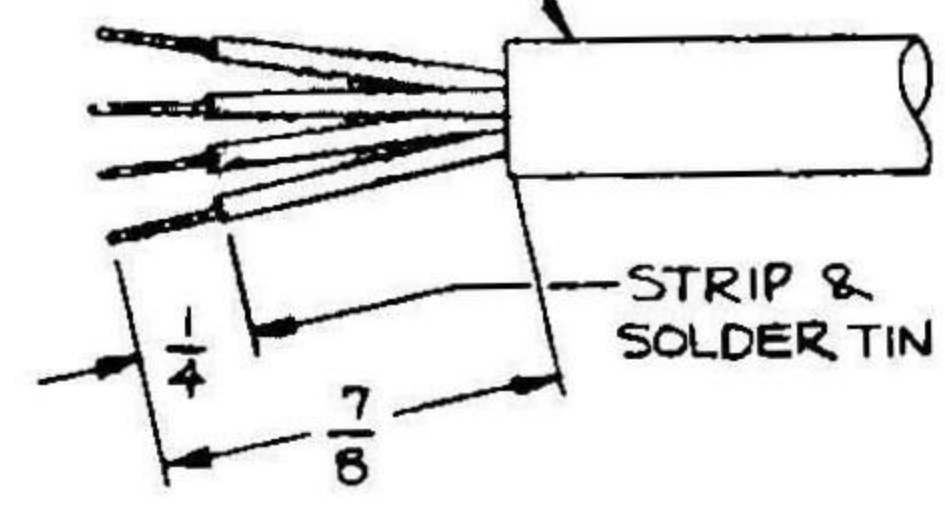

CRIMP SLEEVE TP-102-20

DESIGNED BY IDH	DATE 1/23/87	MATERIAL	
CHECKED BY		FINISH	
APPROVED BY		WEIGHT	SCALE 2:1
UNLESS OTHERWISE SPECIFIED DIMENSIONS ARE IN INCHES TOLERANCES BY FRACTIONS DECIMALS ANGLES		TITLE TELEPHONE JACK	
REVISION A 1) SECT A-A CONFIG CHANGED 1-26-89		DO NOT SCALE DWG. SHEET OF	
		<p style="text-align: center;">NEXUS STAMFORD, CONN.</p> <p style="text-align: right;">C TJ-102</p>	