



Product Specification

Ningbo East Electronics Limited

NO. 88 East Jinhui Road, Yinzhou Ningbo 315100, P.R.China

<http://www.east-mingtao.com>

Product Name:	Pi ezo Buzzer
Part Number :	EFM 320SA
Ver si on:	1. 01
Dat e:	2019- 11- 7
Not e:	

East is an ISO 9001 , IATF16949 and ISO 14001 Certified Company

Revision History

Rev.	Description	Author/Date	Checked By	Approver
1.01	Quality management system revised	汤礼东 2019-11-7	吕文斌	王建成
1.0	Released	汤礼东 2015-4-30	郭波波	王建成

1. Part Number EFM-320SA

2. Dimension Drawing (Unit: mm)

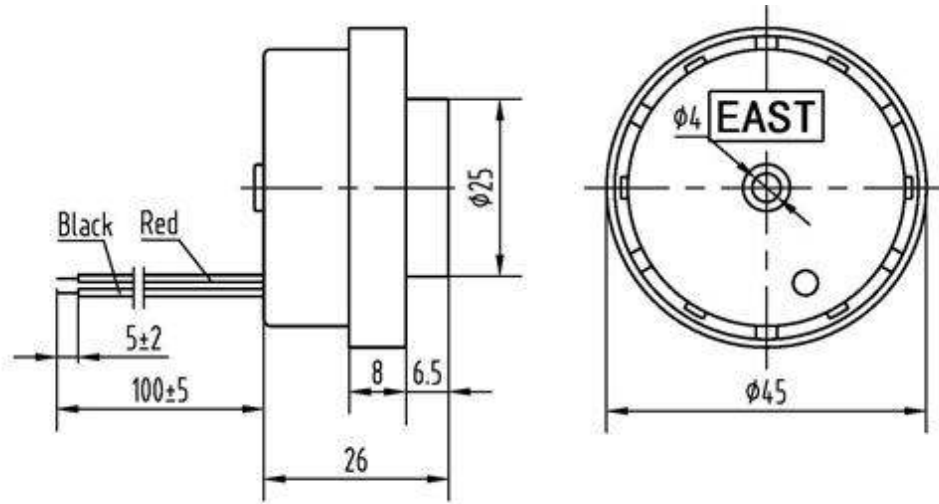

3. Specification

No.	Item	Specification
3-1	Min. Sound Pressure Level	105dB/12V _{DC} /30cm
3-2	Rated Voltage	12V _{DC}
3-3	Operating Voltage	3~16V _{DC}
3-4	Max. Consumption	35mA/12V _{DC}
3-5	Oscillating Frequency	2.9±0.5 kHz
3-6	Tone Nature	Continuous
3-7	Operating Temperature	-20~+70°C
3-8	Case Material/Color	Fire-resistance ABS/White
3-9	Weight	18.8g
3-10	Wire Standard	UL1095-22AWG

NOTES:

Test should be made under the conditions of room temperature (20±10°C), normal humidity (60±20%) and normal atmospheric pressure. In this case, however, that the judgment is questionable, the test conditions are to be changed to room temperature 20±2°C, relative humidity 60~70% and normal atmospheric pressure

4. Typical Frequency Response Curve

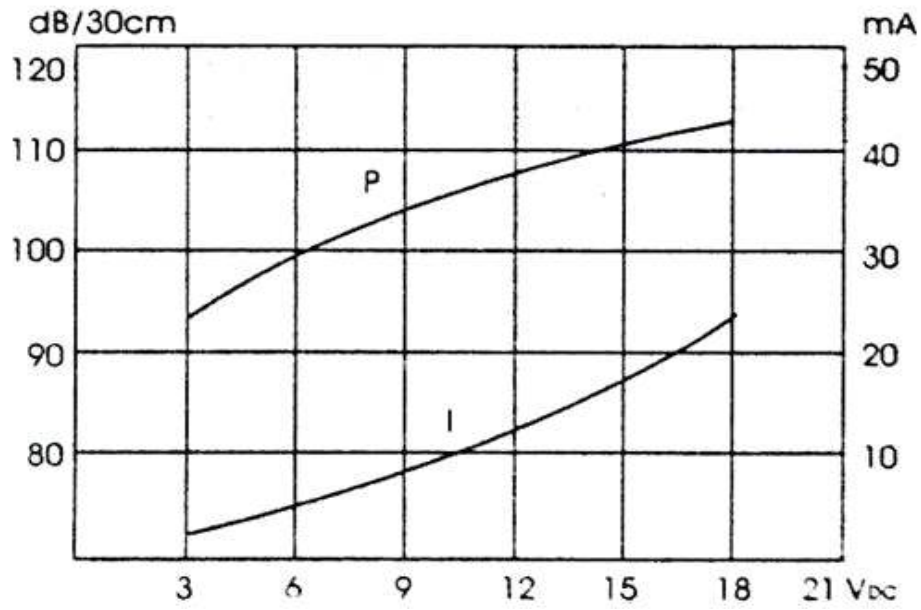

Note:Distance 30 cm

5. Reliability Test

No.	Item	Method of Test	Tolerance after Testing
5-1	Operating Temperature	-20~+70°C	Sound pressure level initial value $\pm 10\text{dB}$ Max. consumption value $\pm 20\%$ Oscillating Frequency value $\pm 20\%$
5-2	Storage in high temperature	Storage in +70°C test box 96 hours then exposed to the room temperature for 2 hours	
5-3	Storage in low temperature	Storage in -20°C test box 96 hours then exposed to the room temperature for 2 hours	
5-4	Life test in the room temperature	Operate the product continuously 5 seconds on 5 seconds off 300 hours at rated voltage	
5-5	Temperature / humidity cycle test	Storage in +40°C, 93 \pm 3%RH test box 96 hours then exposed to the room temperature for 2 hours	
5-6	Temperature (high and low) cycle test	Conduct the test for 5 cycles without applying power then expose to the room temperature for 2 hours.(See Figure 5-6)	
5-7	Vibration test	Conduct the test for the directions of X Y and Z for 0.5 hour each (total 1.5 hours). To-and Fri sweep time(from 10 to 55Hz and then 55 to 10) under single amplitude of 0.75mm is 3 minute, then expose to the room temperature for 2 hours	
5-8	Drop test	Drop a product naturally from the height of 700mm onto the surface of 100mm thick wooden board. Two directions: upper and side of the product are to be applied for this drop test once respectively	

Figure 5-6

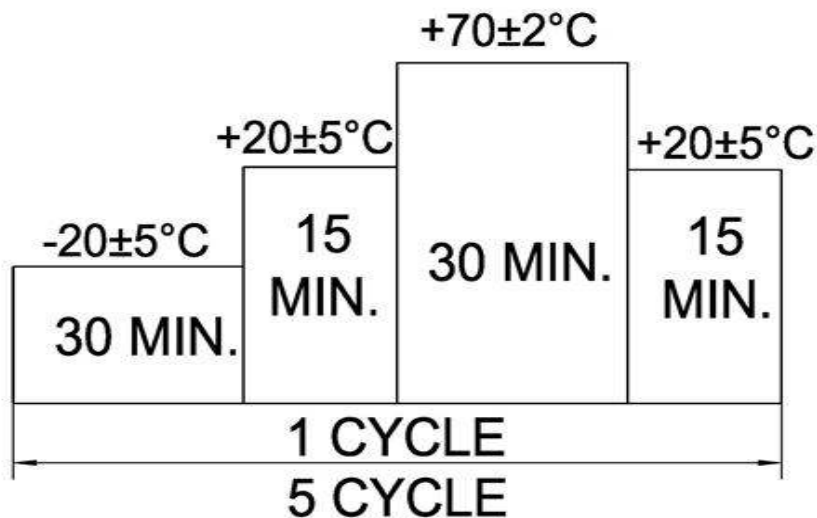

6. Electrical Testing Method

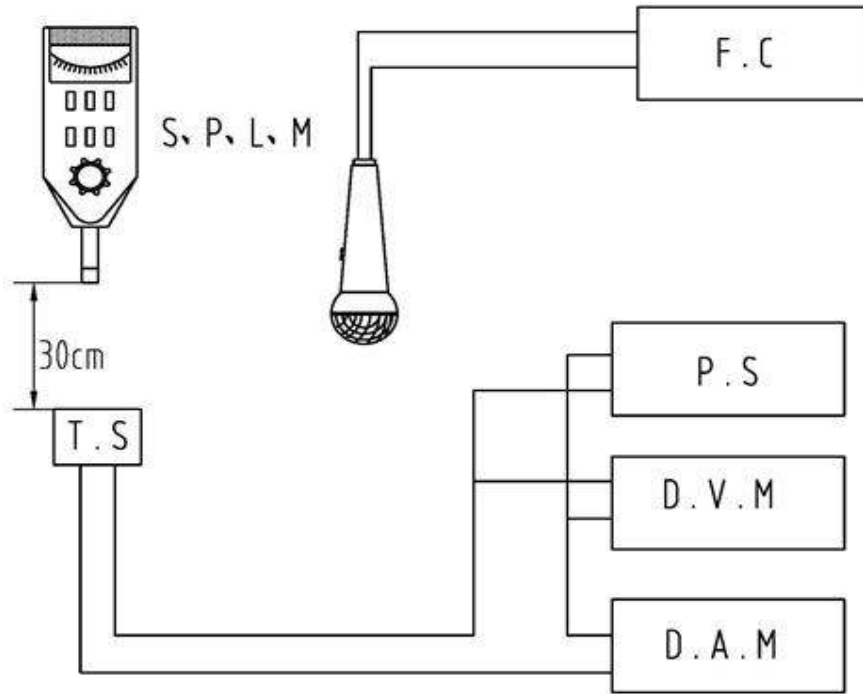

S.P.L.M	Sound Pressure Level Meter
T.S	Testing Sample
F.C	Frequency Counter
P.S	Power Supply
D.V.M	DC Voltage Meter
D.A.M	DC Ampere Meter

7. Packing Information

Packing: 500 pcs per export carton

Carton Size: 47× 30.5× 33 cm

G. Weight: 12.2 kgs N. Weight: 9.4 kgs