

LCD-1B

Multi-configurable Small Flat Panel Articulating Wall Mount

Product Features:

Holds 10" – 23" flat panels

Can be configured as a single arm, double arm or near flush mount with parts provided

Accommodates flat panels w/ 75 or 100 mm VESA hole patterns

Adjustable -5° to +20° tilt

Rotates 240° at the elbow joint (double arm configuration)

Rotates 240° at the flat panel / Rotates 160° at the wall

Feed through wall plate with decorative cover

Clip based cable management system

Load capacity - 25 lbs / Black powder coat finish / UL listed

Also available in silver finish (LCD-1)

Product Specifications:

(for Architects & Engineers)

The wall mount for the flat panel display shall be the Video Mount Products (VMP) model LCD-1. The mount shall be designed to attach to a single stud or other suitable support surface. The mount shall be constructed primarily of tubular steel and shall incorporate nylon filled nuts and arc welds. The mount shall be a universal style mount capable of mounting to all 10" - 23" flat panels that incorporate 75mm and 100mm VESA standard mounting hole patterns and not necessarily be model specific. The mount shall include a cable management system. The mount shall be multi-configurable and capable of being assembled as a double arm articulating, single arm or near flush mount with parts provided. The mount must allow for adjustable tilt from -5° to +20°. The UL listed load capacity shall be 25 lbs.

Video Mount Products

345 Log Canoe Circle Stevensville, MD 21666

Toll Free: 877.281.2169 Telephone: 410.643.6390

Facsimile: 410.643.6615

www.videomount.com

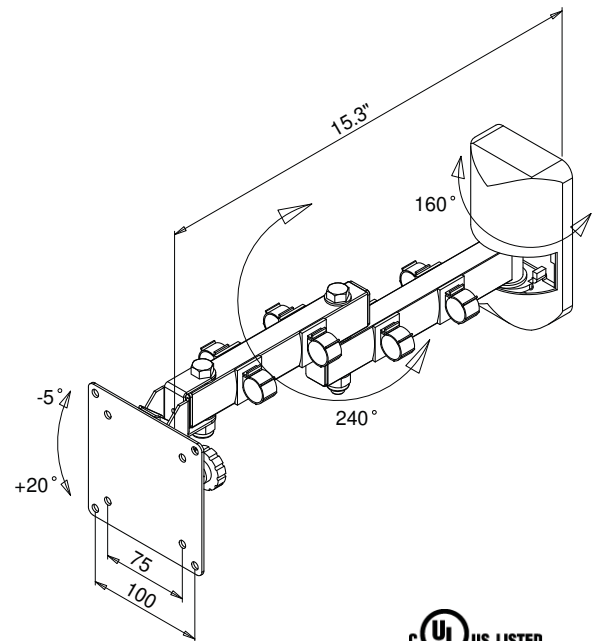
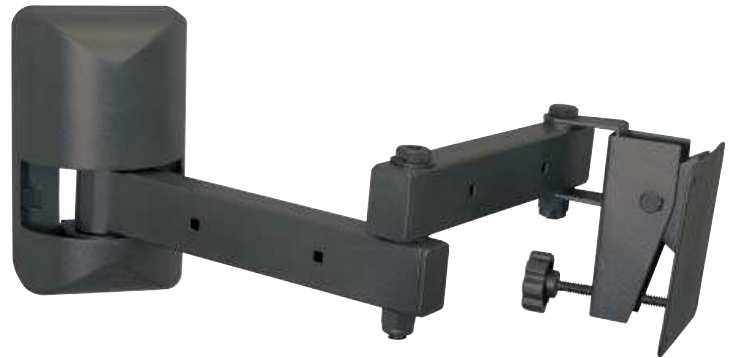

VMP

VIDEO MOUNT PRODUCTS