

# PART NUMBER CODING

## N\_E140DHHN-T9

REVISIONS				
REV.	ECO. NO	DESCRIPTION	DATE	BY
A	1595	INITIAL RELEASE	04/01/08	VJ
B	1707	UPDATE P/N CODING CHART, PLATING	05/30/08	ASK
C	1946	UPDATE NOTES, COLOR CODE & TOLERANCE BLOCK, TAIL LENGTH OPTION 1 REMOVED	06/26/09	JH

### PLATING

(ALL PLATINGS ARE LEAD FREE AND HAVE 50μ" NICKEL UNDERPLATE)

CONTACT SURFACE	TERMINATION
W = GOLD FLASH	.000100" PURE TIN, MATTE
B = .000010" GOLD	.000100" PURE TIN, MATTE
C = .000030" GOLD	.000100" PURE TIN, MATTE

### TAIL LENGTH

2=2.54[.100]  
3=3.00[.118]

### COLOR

1= BLACK  
6= WHITE

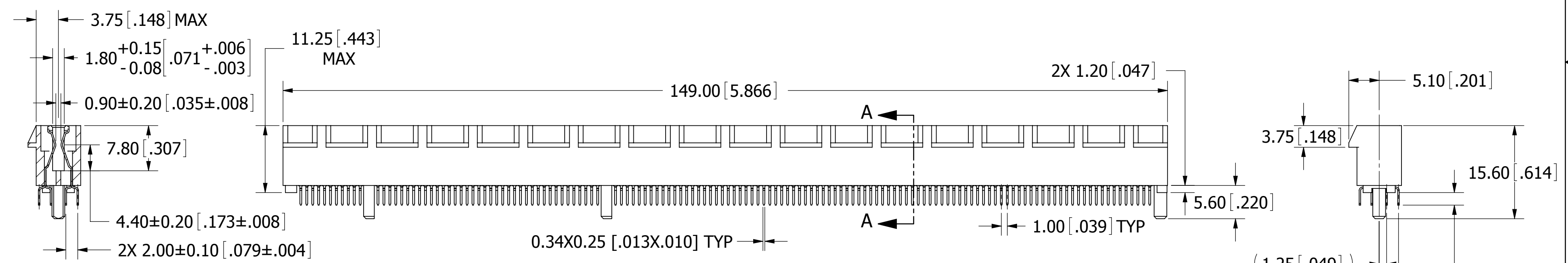
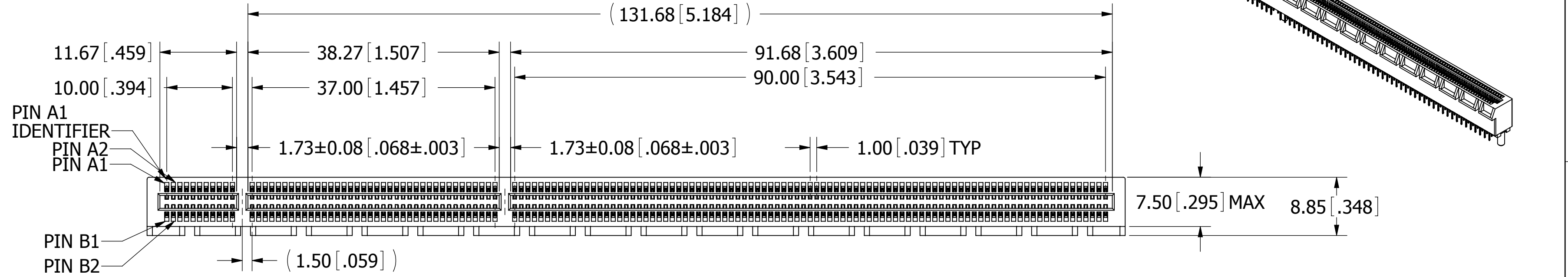
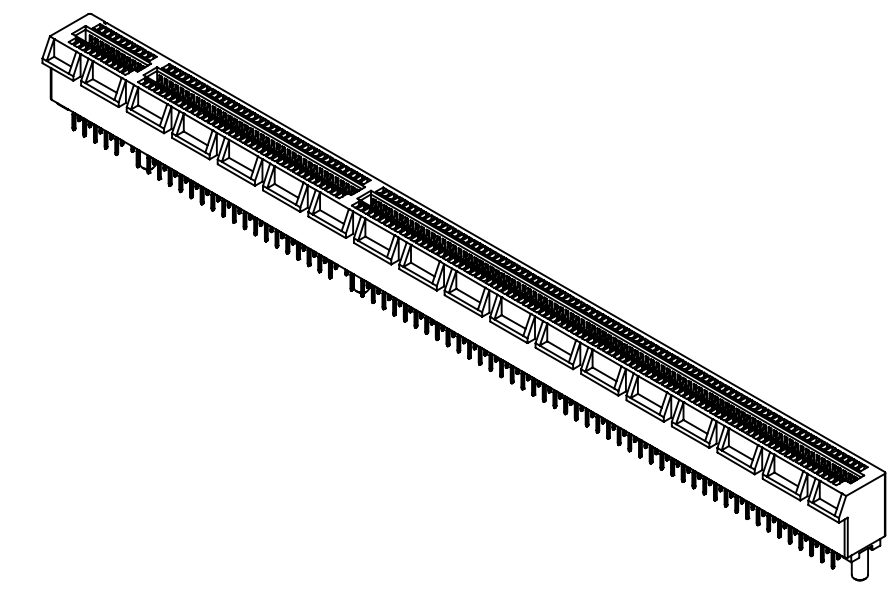

SECTION A-A

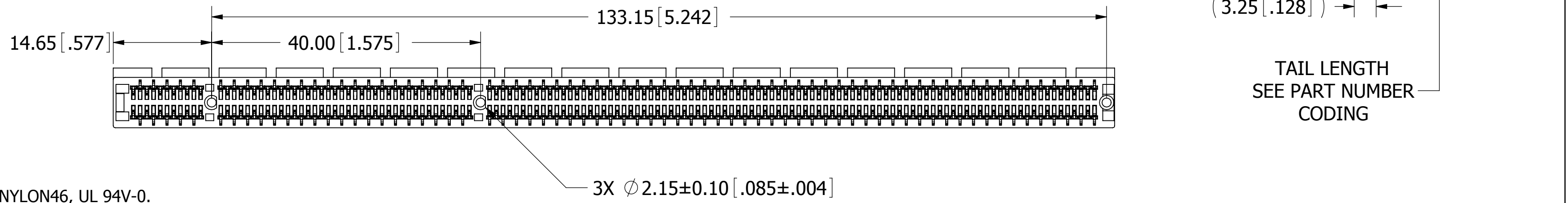

TAIL LENGTH  
SEE PART NUMBER  
CODING

### NOTES:

- INSULATOR MATERIAL: NYLON46, UL 94V-0.
  - CONTACT MATERIAL: PHOSPHOR BRONZE.
  - CONTACT PLATING: SEE PART NUMBER CODING.
  - CURRENT RATING: 1.1 AMP.
  - VOLTAGE RATING: 50 V DC.
  - INSULATOR RESISTANCE: 1000 MEGOHMS MIN.
  - CONTACT RESISTANCE: 30 MILLI OHMS MAX.
  - DIELECTRIC WITHSTANDING: 500V DC.
  - INSERTION FORCE: 117gf (1.15 N) MAX PER CONTACT PAIR USING A 1.7 mm (.067") STEEL CARD.
  - WITHDRAWAL FORCE: 15.3gf (0.15 N) MIN PER CONTACT PAIR USING A 1.44 mm (.057") STEEL CARD.
  - OPERATING TEMPERATURE: -55° C TO +105° C.
  - PROCESSING TEMP.: 260° C FOR 10 SECS MAX.
- (INDICATED TEMPERATURE AND TIME IS FOR COMPONENT INSULATOR. HIGHER PROCESSING TEMPERATURE MAY BE USED, PROVIDED HEAT IS APPLIED FROM BACK SIDE OF PCB, AND INSULATOR DOES NOT EXCEED INDICATED TEMPERATURE AND TIME.)

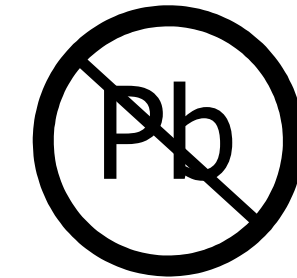

RoHS COMPLIANT

UNLESS OTHERWISE SPECIFIED:  
DIMENSIONS ARE IN MM[INCHES]  
TOLERANCES:  
ANGULAR: ± 5°  
.X= ± .3 [.01]  
.XX= ± .25 [.010]  
.XXX= ± .080 [.0030]  
SURFACE FINISH: 63 R<sub>a</sub>  
REMOVE ALL BURRS AND SHARP EDGES .010 MAX

INTERPRET DIMENSIONS AND GEOMETRIC TOLERANCING PER: ANSI Y14.5M-1994

DRAWN		DATE	NAME	
DRAWN		3/23/09	JH	
<small>THE INFORMATION HEREIN CONTAINS PROPRIETARY INFORMATION OF SULLINS ELECTRONICS AND IS NOT TO BE REPRODUCED, USED OR DISCLOSED TO OTHERS FOR ANY PURPOSE EXCEPT AS SPECIFICALLY AUTHORIZED IN WRITING BY AN OFFICER OF SULLINS ELECTRONICS.</small>				DESCRIPTION PCI EXPRESS, 1mm CC, 140P, DIP SOLDER PART NUMBER <b>N_E140DHHN-T9</b>
SIZE	DWG. NO.	REV		
<b>C</b>	11040	<b>C</b>		
SCALE: 1:1		SHEET 1 OF 2		

8 7 6 5 4 3 2 1

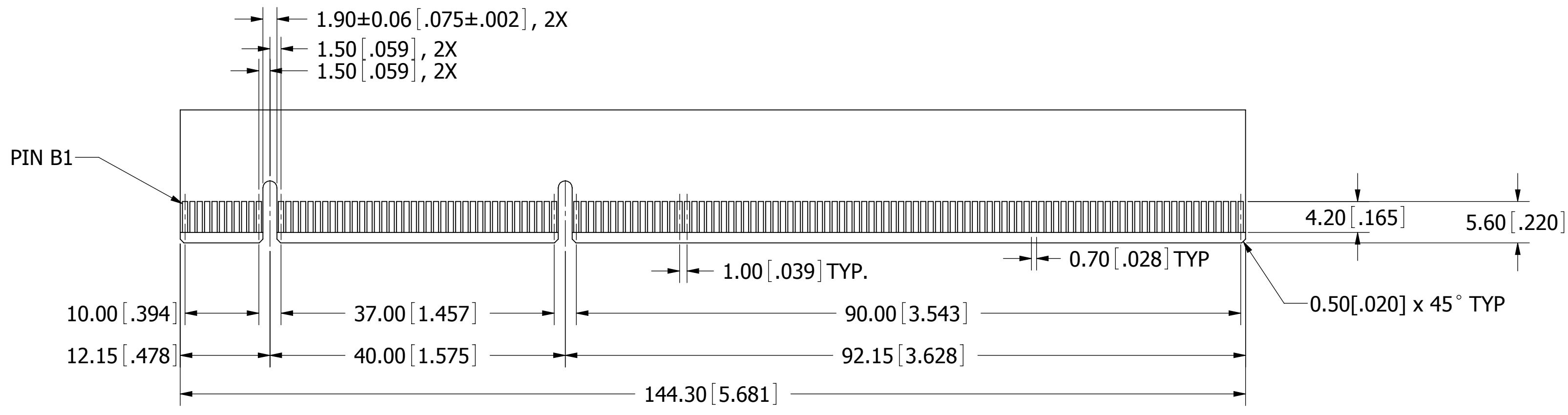
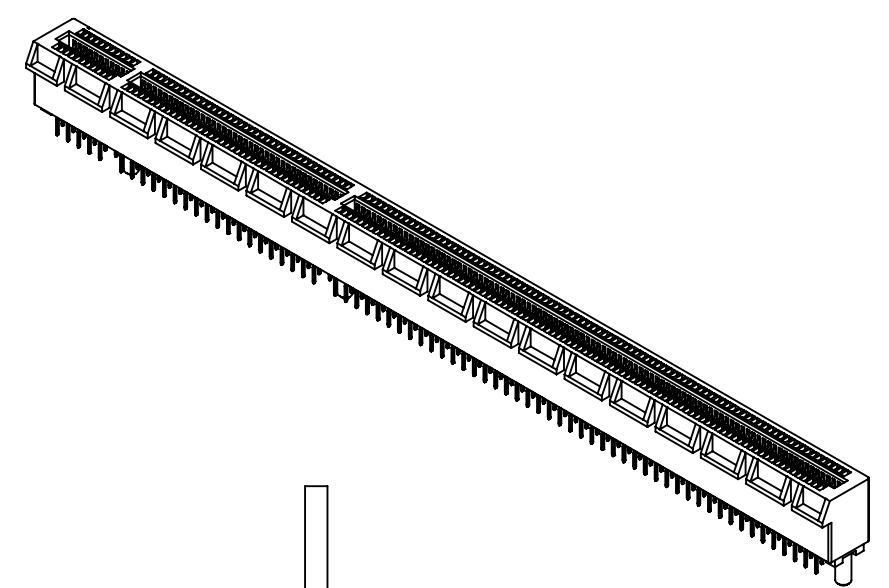

**I/O PANEL DIRECTION PRIMARY (COMPONENT) SIDE**

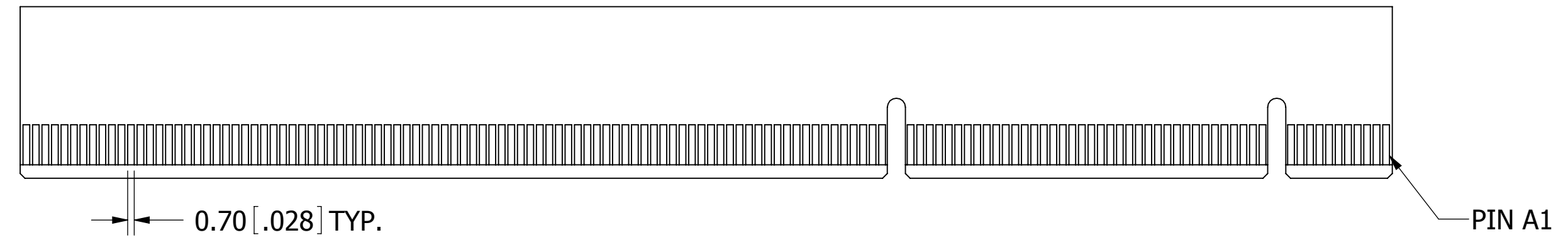

**I/O PANEL DIRECTION SECONDARY (SOLDER) SIDE**  
**ADD-IN CARD EDGE-FINGER DIMENSIONS**

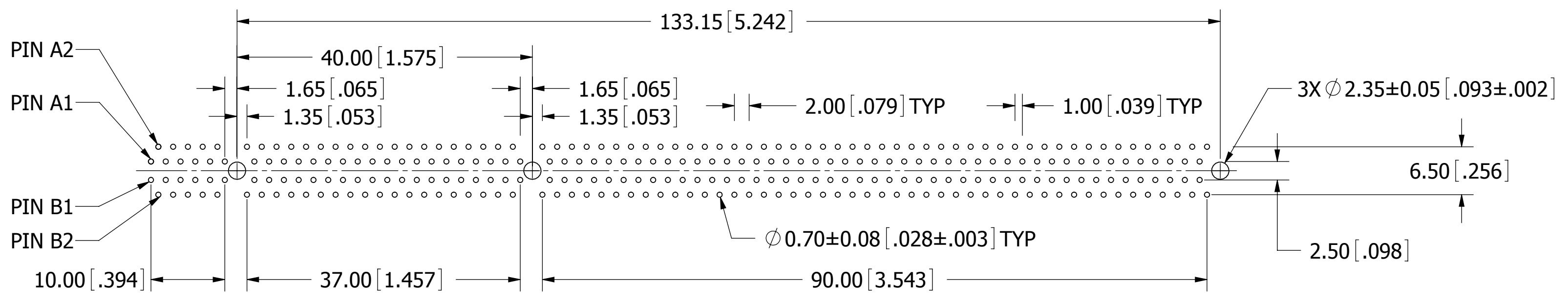
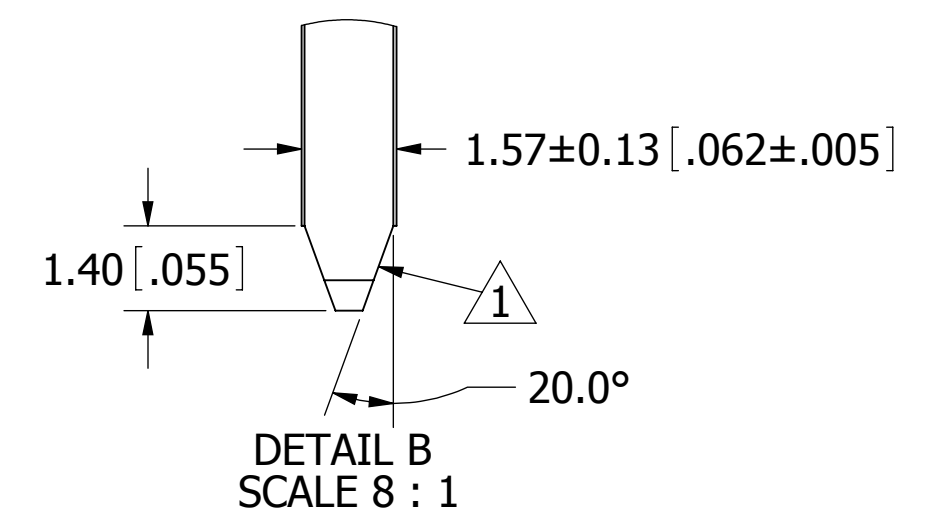

**RECOMMENDED PCB LAYOUT**  
 TOLERANCE: ±0.13 [.005]

1. CHAMFER EDGE MUST BE FREE OF CUTTING BURRS.

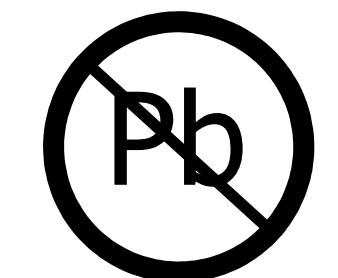

**RoHS COMPLIANT**

DESCRIPTION PCI EXPRESS, 1mm CC, 140P, DIP SOLDER		
PART NUMBER N_E140DHNN-T9_		
SIZE <b>C</b>	DWG. NO. 11040	REV <b>C</b>
SCALE: NTS		SHEET 2 OF 2