

THIS DRAWING IS UNPUBLISHED. RELEASED FOR PUBLICATION 2014
 © COPYRIGHT 2014 BY - ALL RIGHTS RESERVED.

| REVISIONS | | | | | |
|-----------|-----|-------------|-----------|------|------|
| P | LTR | DESCRIPTION | DATE | DWN | APVD |
| A | | RELEASED | 11MAR2015 | Y. S | M. K |
| A1 | | REVISED | 16MAR2015 | Y. S | M. K |
| B | | REVISED | 28JAN2016 | Y. S | M. K |
| B1 | | REVISED | 19JUL2021 | Y. S | M. K |

ROHS COMPLIANT

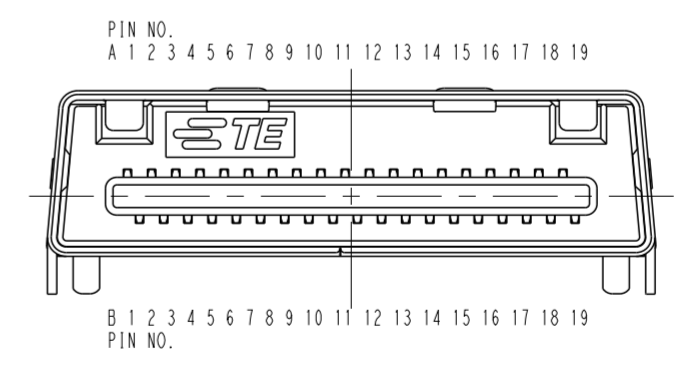
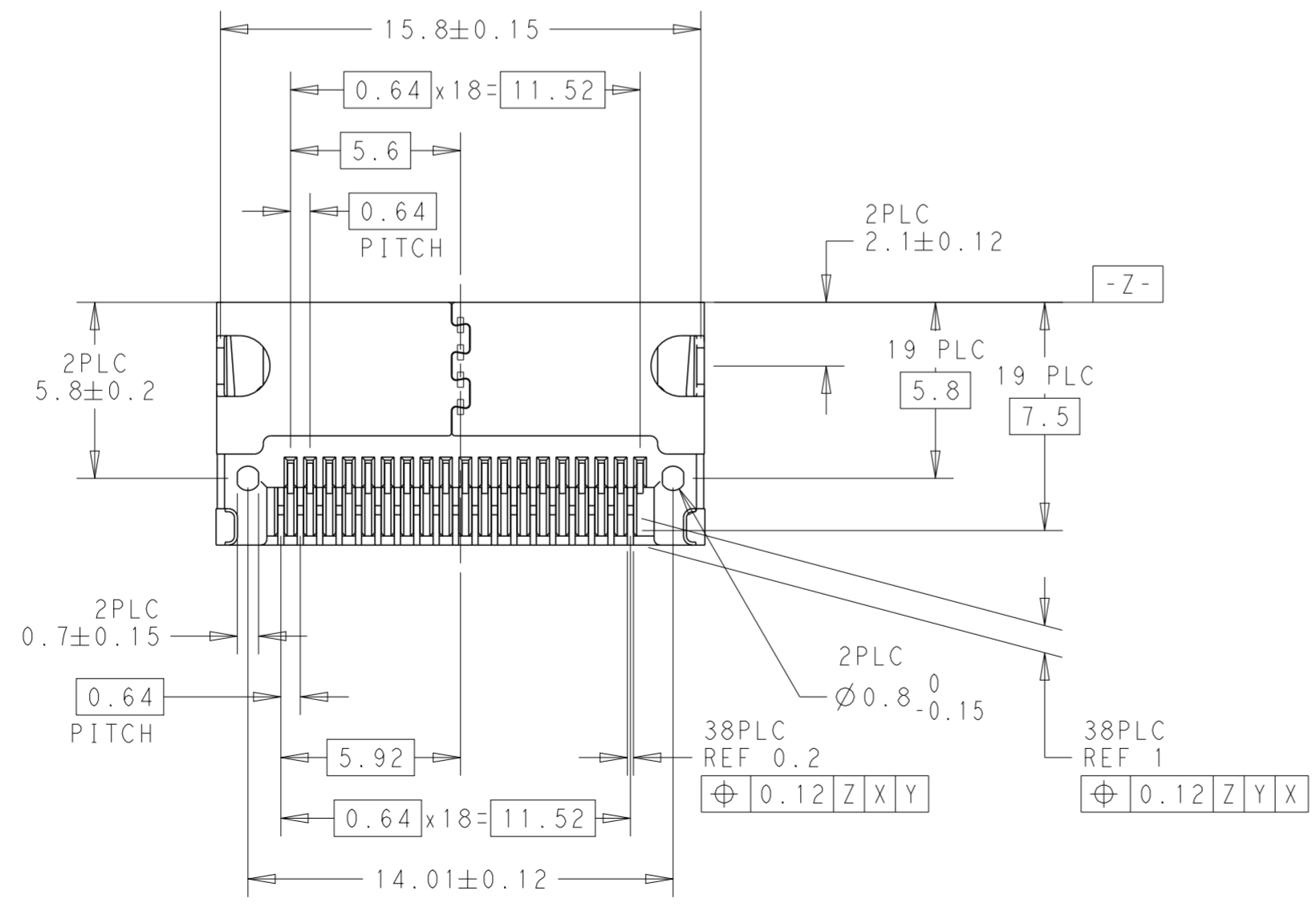
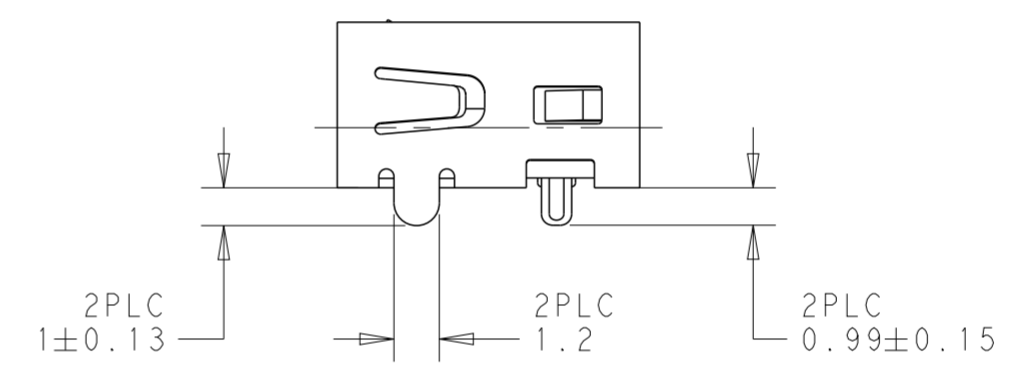
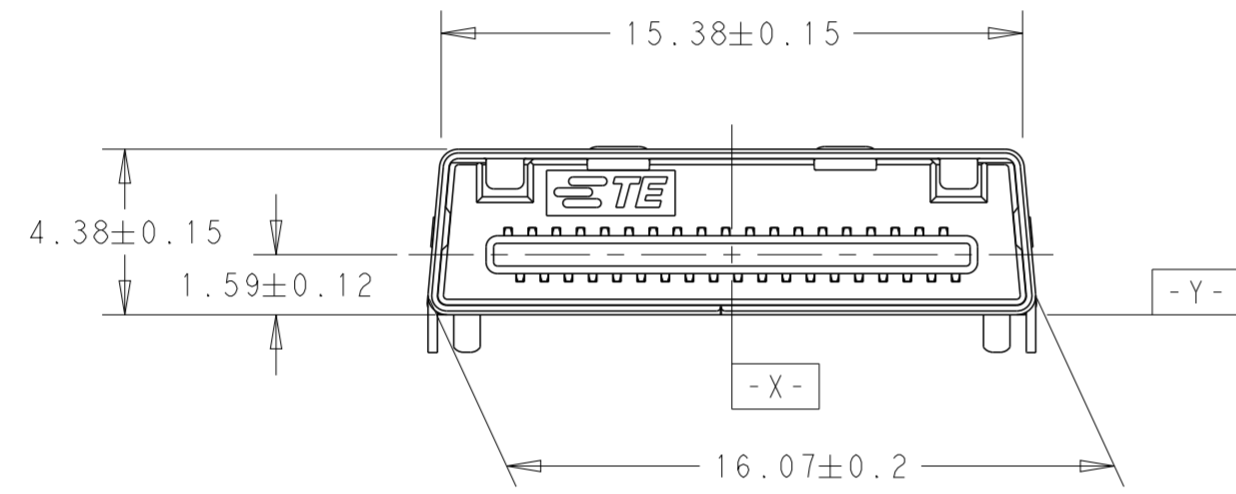
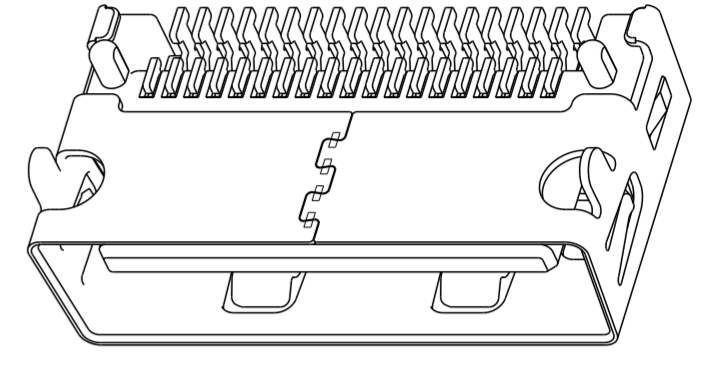
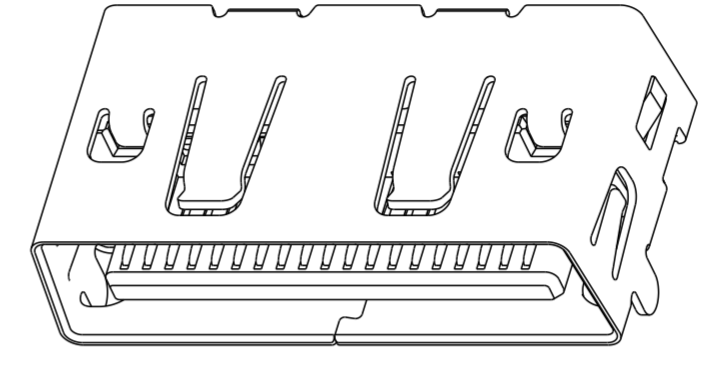
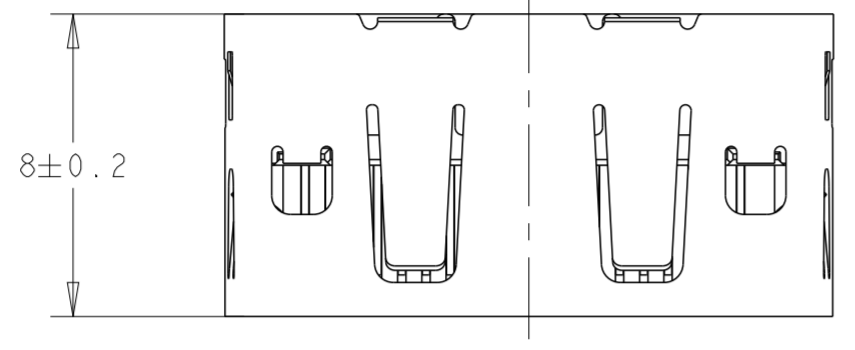

| | | | | |
|----------------------------------------|--|--------------------------|---------------------------------|-----------------|
| THIS DRAWING IS A CONTROLLED DOCUMENT. | | DWN Y. SASAKI 09DEC2013 | TE Connectivity | |
| DIMENSIONS: mm | | CHK M. KIMURA 09DEC2013 | | |
| TOLERANCES UNLESS OTHERWISE SPECIFIED: | | APVD M. KIMURA 09DEC2013 | NAME | |
| 0-PLC ±0.15 | | PRODUCT SPEC | RECEPTACLE CONNECTOR ASSEMBLY | |
| 1-PLC ±0.1 | | APPLICATION SPEC | HASAKI 38P RECEPTACLE CONNECTOR | |
| 2-PLC ±0.01 | | 108-140067 | KEEN EDGE CONNECTOR SERIES | |
| 3-PLC ±0.001 | | WEIGHT 1.02g | SIZE A2 | CAGE CODE - |
| 4-PLC ±0.0001 | | CUSTOMER DRAWING | DRAWING NO. C-2822022 | RESTRICTED TO - |
| ANGLES ±0.5 | | SCALE 5:1 | SHEET 1 OF 2 | REV B1 |
| FINISH - | | | | |
| MATERIAL SEE TABLE 1 | | | | |

| REVISIONS | | | | | |
|-----------|-----|-------------|------|-----|------|
| P | LTR | DESCRIPTION | DATE | DWN | APVD |
| - | | SEE SHEET 1 | - | - | - |
| | | | | | |
| | | | | | |

RoHS COMPLIANT

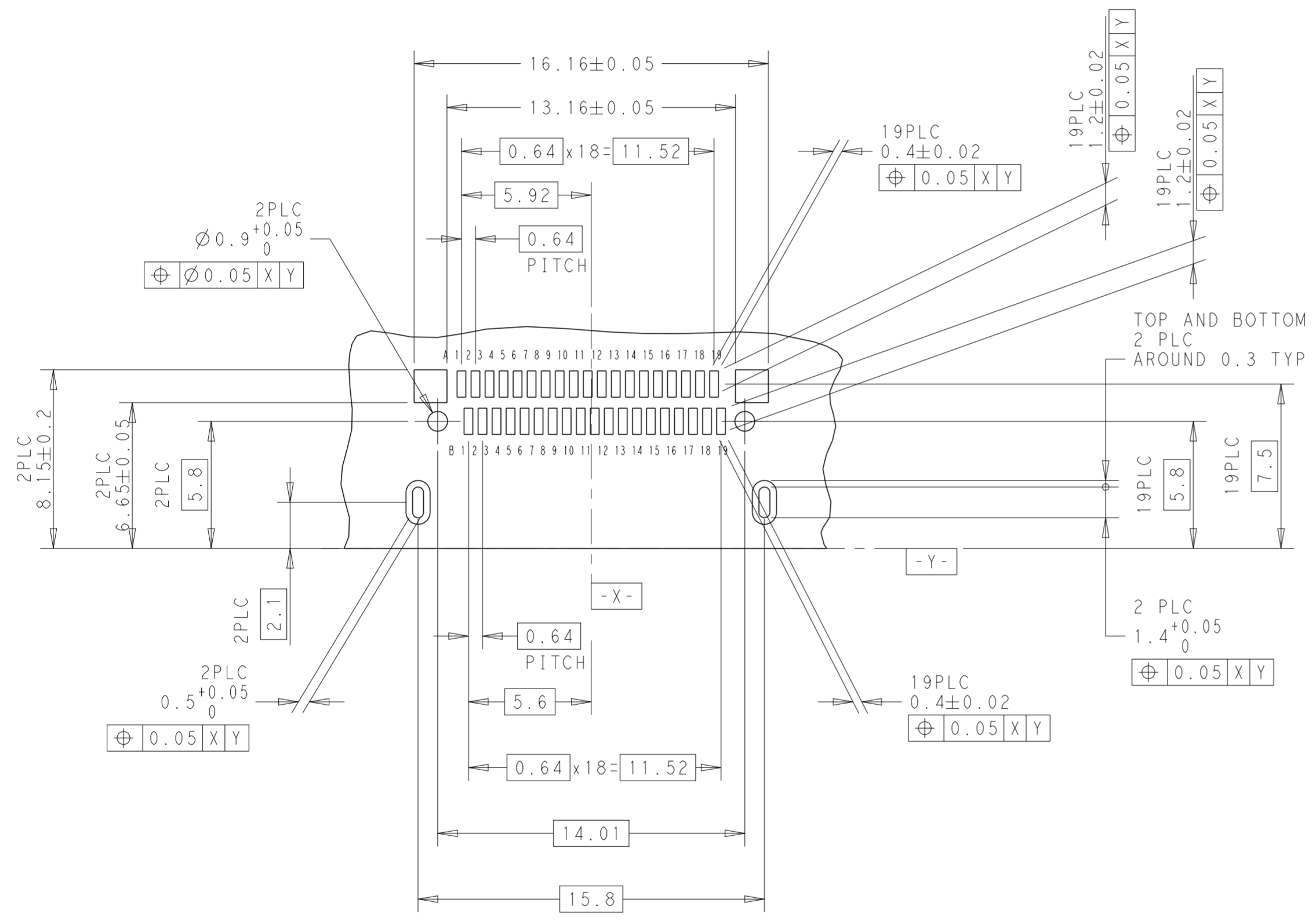

① ② ③ ④

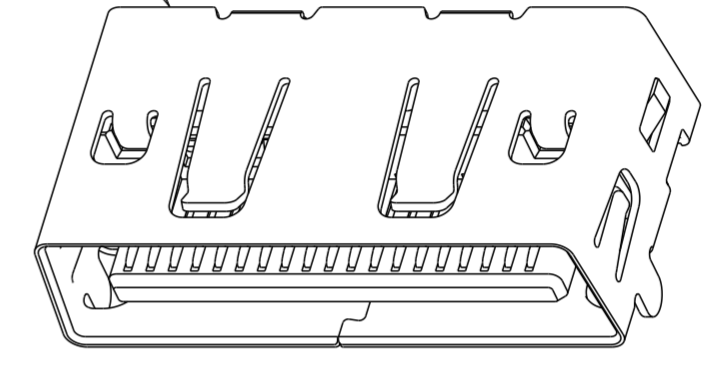

1. USED MATERIAL : SEE TABLE
2. REFLOW OR SPLDERING
 REFLOW CONDITION : AIR REFLOW, TEST PCB BOARD THICKNESS : 1.8 mm MAX.
 PEAK 250°C-255°C, 230°C MIN 30±10sec, 150°C-180°C 90±30sec.

| QTY | DESCRIPTION | MATERIAL | ITEM NO. |
|-----|--------------------------------------------------------|------------------|----------|
| 1 | RECEPTACLE OUTER SHELL KEEN EDGE CONNECTOR SERIES | PH BRONZE | 4 |
| 19 | RECEPTACLE LOWER CONTACT KEEN EDGE CONNECTOR SERIES | BERYLLIUM COPPER | 3 |
| 19 | RECEPTACLE UPPER CONTACT KEEN EDGE CONNECTOR SERIES | BERYLLIUM COPPER | 2 |
| 1 | RECEPTACLE HOUSING KEEN EDGE CONNECTOR SERIES | LCP BLACK | 1 |
| - 1 | NAME | MATERIAL | ITEM NO. |

RECEPTACLE PCB FOOTPRINT
SCALE 5:1

THIS DRAWING IS A CONTROLLED DOCUMENT.

DWN Y. SASAKI 09DEC2013
 CHK M. KIMURA 09DEC2013
 APVD M. KIMURA 09DEC2013

STE TE Connectivity

NAME RECEPTACLE CONNECTOR ASSEMBLY
 HASAKI 38P RECEPTACLE CONNECTOR
 KEEN EDGE CONNECTOR SERIES

PRODUCT SPEC 108-140067
 APPLICATION SPEC -

SIZE A2 CAGE CODE - DRAWING NO. C-2822022 RESTRICTED TO -

MATERIAL SEE TABLE 1 FINISH - WEIGHT 1.02g SCALE 5:1 SHEET 2 OF 2 REV B1

CUSTOMER DRAWING