

NOTES:

- 1- MATERIAL :
 - HOUSING : - LCP GLASS FILLED UL 94V0, COLOR: BLACK
 - TERMINAL : COPPER ALLOY PLATED WITH :
 - PLATING 2: 0.00127 MIN GOLD IN CONTACT AREA, 0.00190 MIN TIN IN TAIL AREA, BOTH OVER 0.00127 MIN NICKEL OVERALL
 - PLATING 7: POST PLATE 0.00005 MIN GOLD FLASH OVER 0.00060 MIN PALLADIUM NICKEL IN CONTACT AREA 0.00190 MIN TIN IN TAIL AREA BOTH OVER 0.00127 MIN NICKEL OVERALL.
 - SHIELD : COPPER ALLOY PLATED WITH 0.0020 MIN. TIN
- 2- P.C. BOARD THICKNESS : 1.57 ±0.15
- 3- JACK FOR MATING WITH F.C.C. 68 PLUGS 95043 MOLEX SERIES.
- 4- PRODUCT SPECIFICATION: PS-95540-002
- 5- PACKAGING SPECIFICATION: MOLEX PK-95040
- 6- MANUFACTURING I.D. CAN BE EITHER MXF, MG OR MXI. LAST INSPECTION NUMBER: 16

PART NUMBER	PLATING
95540-2881	2
95540-7881	7

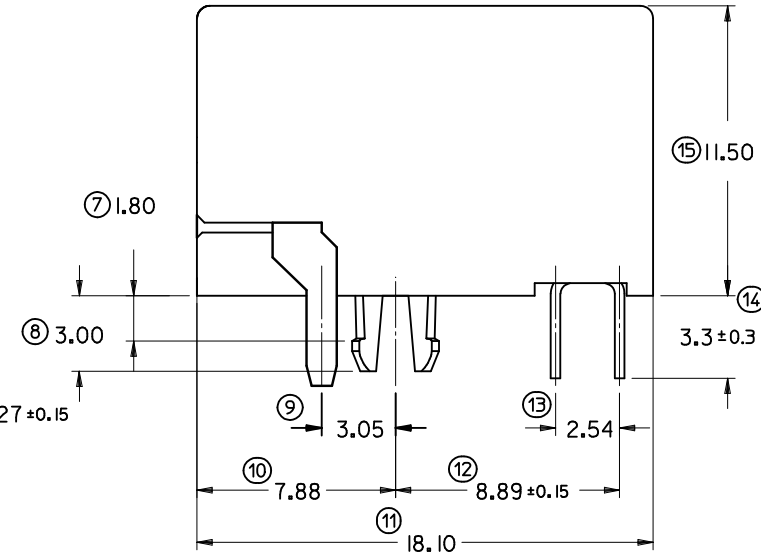
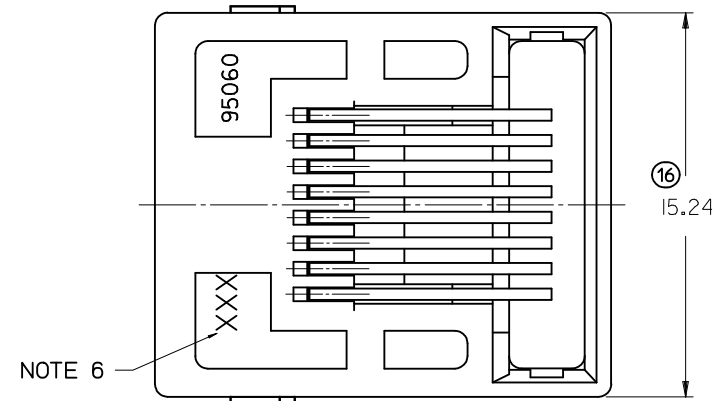
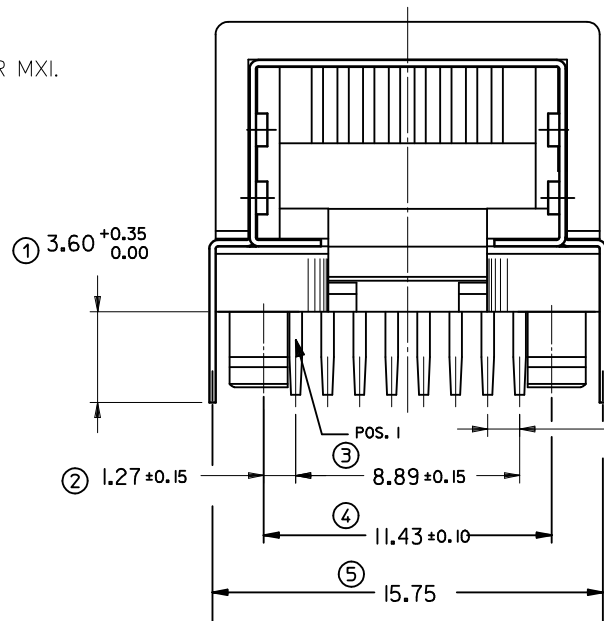
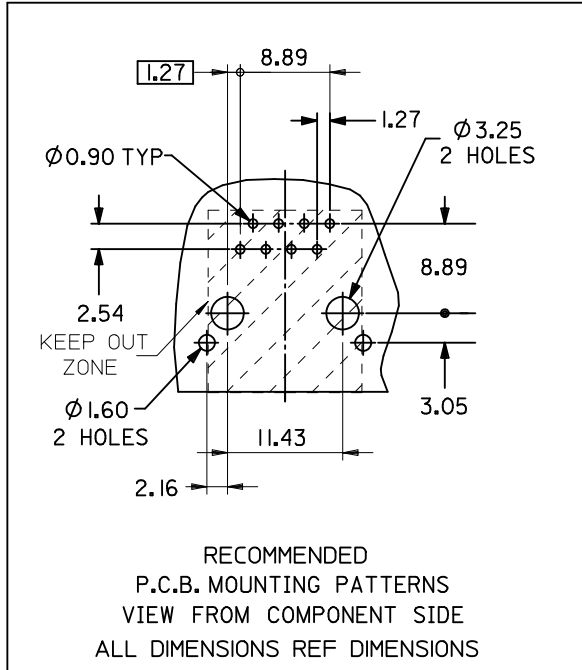

ADDED OPTION EC NO: E2012-0079 DRWN: JCONNOR 2011/03/11 CHKD: APPR: EFOLAN 2011/09/28	QUALITY SYMBOLS ▽=0 C=0	GENERAL TOLERANCES (UNLESS SPECIFIED)		DIMENSION STYLE MM ONLY		SCALE 5:1	DESIGN UNITS METRIC	THIRD ANGLE PROJECTION	
		mm	INCH	DRAWN BY KNOLLER	DATE 04/06/18	TITLE RIGHT ANGLE LOW PROFILE SHIELDED PC JACK (THROUGH HOLE VERSION)			
D	REV	4 PLACES	± ---	± ---	CHECKED BY FCARABET	DATE 04/08/28	MOLEX INCORPORATED		
		3 PLACES	± ---	± ---	APPROVED BY KNOLLER	DATE 04/06/29	DOCUMENT NO. SD-95540-001		SHEET NO. 1 OF 3
		2 PLACES	± 0.1	± ---	THIS DRAWING CONTAINS INFORMATION THAT IS PROPRIETARY TO MOLEX INCORPORATED AND SHOULD NOT BE USED WITHOUT WRITTEN PERMISSION				
		1 PLACE	± 0.15	± ---					
		ANGULAR ±1/2°		MATERIAL NO. SEE CHART					
		DRAFT WHERE APPLICABLE MUST REMAIN WITHIN DIMENSIONS		SIZE A3					