

THIS DRAWING IS UNPUBLISHED. RELEASED FOR PUBLICATION  
 © COPYRIGHT - By - ALL RIGHTS RESERVED.

LOC		DIST		REVISIONS			
P	LTR	DESCRIPTION	DATE	DWN	APVD		
B1		REVISED PER ECO-11-004917	11MAR11	RK	HMR		

CONVERSION CHART	
INCH	MM
.010	0,25
.020	0,51
.030	0,76
.040	1,01
.100	2,54
.105	2,67
.110	2,79
.130	3,30
.200	5,08
.206	5,23
.220	5,59
.320	8,13
.360	9,14
.380	9,65
.400	10,16

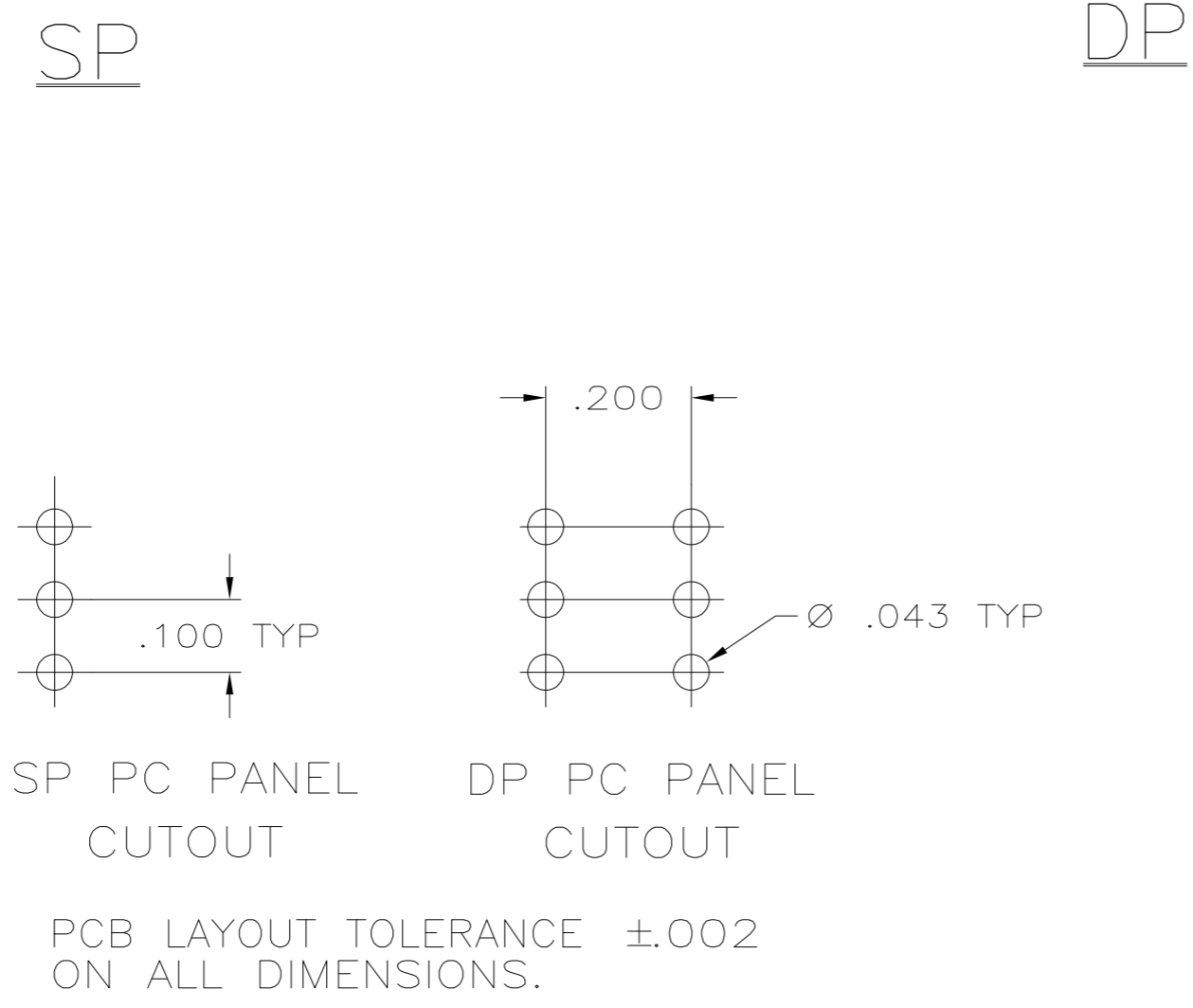
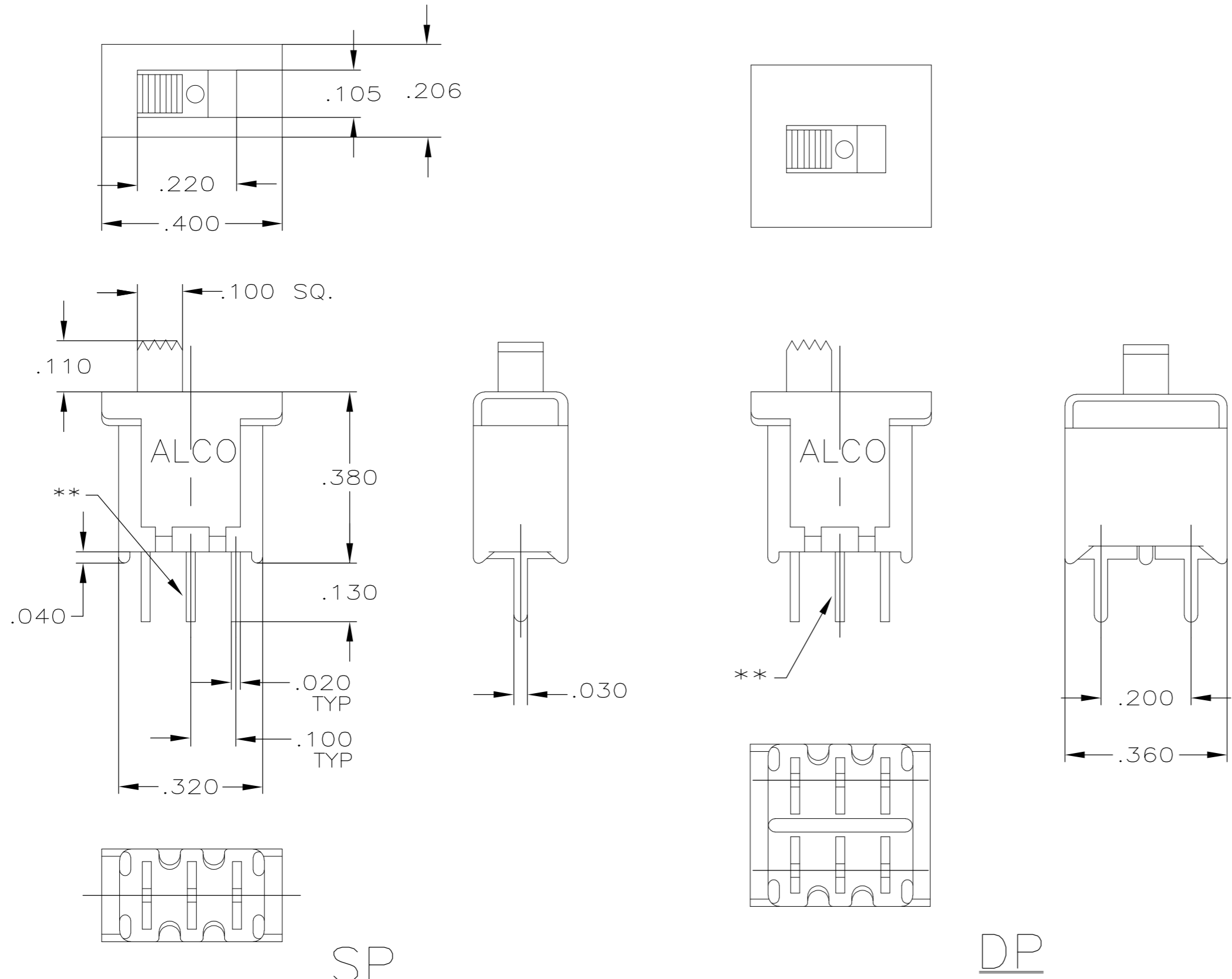

SPECIFICATIONS:

**MATERIALS:**  
 CASE: LCP, 94V-0.  
 ACTUATOR: PBT, 94V-0.  
 MOVING CONTACT: COPPER, GOLD PLATE OVER NICKEL.  
 FIXED CONTACT/TERMINAL: COPPER, GOLD PLATE OVER NICKEL.

**ELECTRICAL:**  
 CONTACT RATING: 0.4 VA MAX. @ 20 VDC OR PEAK AC.  
 INITIAL CONTACT RESISTANCE: 20 MILLIOHMS MAX. @ 100 MV & 1 MA.  
 INSULATION RESISTANCE: 1,000 M. MIN. AT 500 VDC.  
 DIELECTRIC STRENGTH: 1000 VOLTS RMS AT SEA LEVEL.  
 LIFE: 60,000 - 80,000 CYCLES.

**MECHANICAL:**  
 ACTUATION FORCE: (EG OPTION ONLY)  
 LEFT TO CENTER & RIGHT TO CENTER: 160 TO 665 GRAMS WITH AN AVERAGE OF 412 GRAMS WHILE UTILIZING A 3 SIGMA VARIATION.  
 CENTER TO RIGHT & CENTER TO LEFT: 170 TO 685 GRAMS WITH AN AVERAGE OF 428 GRAMS WHILE UTILIZING A 3 SIGMA VARIATION.

**ENVIRONMENTAL:**  
 OPERATING TEMPERATURE: -4°F TO +176°F (-20°C TO +80°F).  
 STORAGE TEMPERATURE: -4°F TO +176°F (-20°C TO +80°F).

NOTES:

- INTERPRET DRAWING PER ASME Y14.5M-1994.
- SOLDERABILITY PER EIA 364-52, CLASS 2, CATEGORY 1

\*\* CENTER TERMINAL NOT FURNISHED WITH A & K ACTION CODES.

THIS DRAWING IS A CONTROLLED DOCUMENT.		DWN R BROWN 06SEP2007	<b>TE</b> TE Connectivity	
DIMENSIONS: INCHES		CHK M SARVER 06SEP2007		
TOLERANCES UNLESS OTHERWISE SPECIFIED:		APVD M SARVER 06SEP2007	NAME SLIDE SWITCH	
0 PLC ± -		PRODUCT SPEC	SIZE CAGE CODE DRAWING NO RESTRICTED TO	
1 PLC ± -		APPLICATION SPEC	A2 00779 C=1437579-8	
2 PLC ± -		WEIGHT -	SCALE 4:1 SHEET 1 OF 1 REV B1	
3 PLC ± .010		CUSTOMER DRAWING		
4 PLC ± -				
ANGLES ± -				
FINISH -				