

TLE4959-5U FX FlexibleTransmission Speed Sensor



Features

- Hall based differential speed sensor
- High magnetic sensitivity
- Large operating airgap
- Dynamic self-calibration principle
- Adaptive hysteresis
- Output protocol with and without direction of rotation detection
- High vibration suppression capabilities
- Three wire voltage interface
- Magnetic encoder and ferromagnetic wheel application
- High immunity against ESD, EMC and mechanical stress, improved voltage dropout capability
- Automotive operating temperature range
- End-of-line programmable to adjust transmission requirements
- Green Product (RoHS compliant)
- AEC Qualified

Applications

The TLE4959-5U FX is an integrated differential Hall speed sensor ideally suited for transmission applications. Its basic function is to provide information about rotational speed and direction of rotation to the transmission control unit. TLE4959-5U FX includes a sophisticated algorithm which actively suppresses vibration while keeping excellent airgap performance.

Table 1 Description

Type	Marking	Ordering Code	Package
TLE4959-5U FX	59AYA1	SP001040496	PG-SSO-4-1

Description

The TLE4959-5U FX comes in a RoHs compliant four-pin package, qualified for automotive usage. the recommended capacitors increase the EMC robustness of the device. In 12V applications it is further recommended to use a serial resistor R_{Supply} for protection on the supply line. A pull-up resistor R_{Load} is mandatory on the output pin and determines the maximum current flowing through the output transistor. A value of 1.2 k Ω is recommended for the 5V application. (see [Figure 1](#))

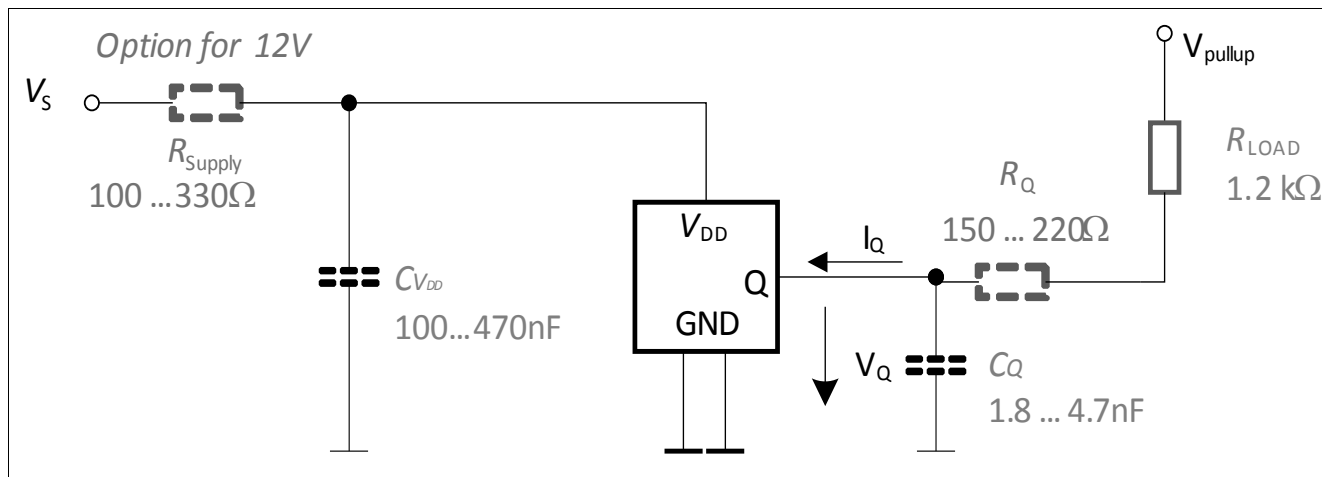

Figure 1 Typical Application Circuit

Functional Description

1 Functional Description

The differential Hall sensor IC detects the motion of tooth and magnet encoder applications. To detect the motion of ferromagnetic objects, the magnetic field must be provided by a back biasing permanent magnet. Either south or north pole of the magnet can be attached to the rear unmarked side of the IC package (See [Figure 2](#)). The magnetic measurement is based on three equally spaced Hall elements, integrated on the IC. Both magnetic and mechanical offsets are cancelled by a self calibration algorithm.

1.1 Definition of the Magnetic Field Direction

The magnetic field of a permanent magnet exits from the north pole and enters the south pole. If a north pole is attached to the backside of the High End Transmission Sensor, the field at the sensor position is positive, as shown in [Figure 2](#).

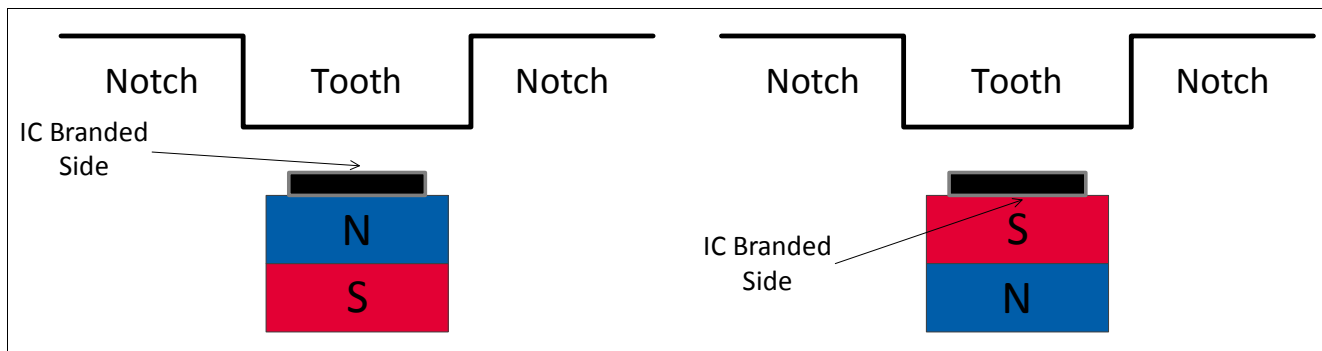

Figure 2 Definition of the Positive Magnetic Field Direction

1.2 Block Diagram

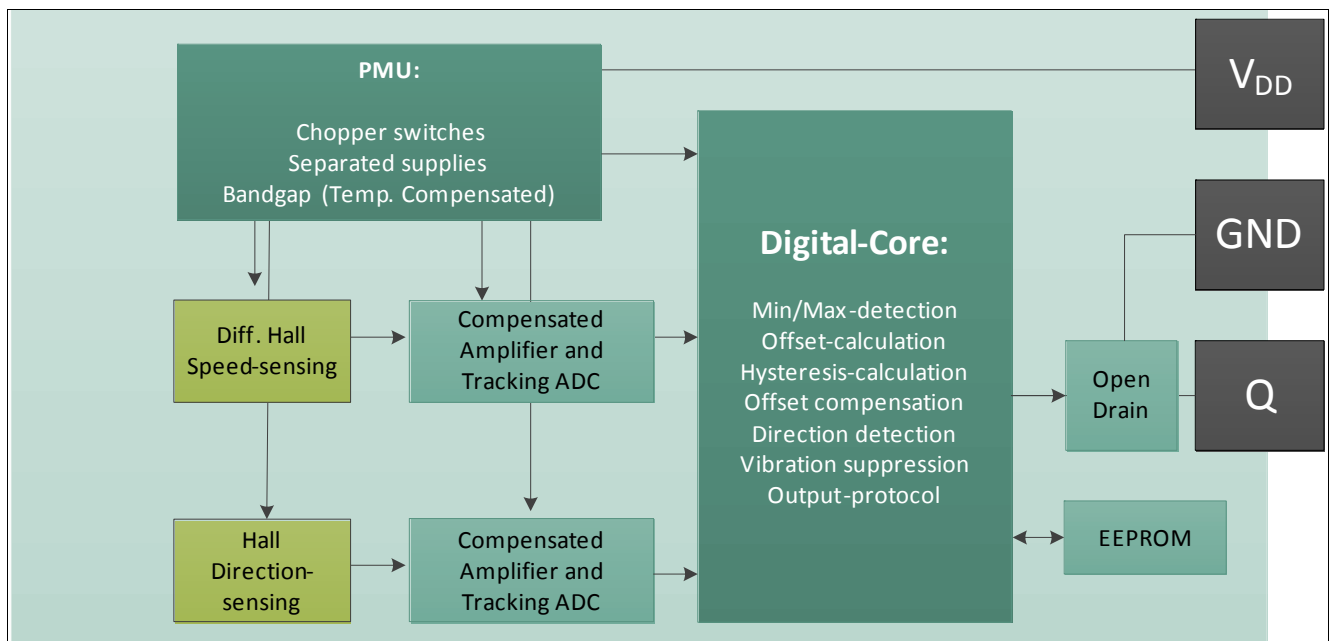

Figure 3 Block Diagram

Functional Description

1.3 Basic Operation

The speed signal calculated out of the differential hall elements, is amplified, filtered and digitized. An algorithm in the digital core for peak detection and offset calculation will be executed. The offset is fed back into the speed signal path with a digital to analog converter for offset correction. During uncalibrated mode, the output of the speed pulse is triggered in the digital core by exceeding a certain threshold of the tracking ADC. In calibrated mode the output is triggered by the visible hysteresis.

The direction signal is calculated out of center Hall signals. The direction signal is amplified, filtered, and digitized. In the digital core the direction and the vibration detection information is determined and the output protocol is issued.

1.4 Uncalibrated and Calibrated Mode

After power on the differential magnetic speed signal is tracked by an analog to digital converter (Tracking ADC) and monitored within the digital core. If the signal slope is identified as a rising edge or falling edge, the first output pulse is triggered. A second trigger pulse is issued with direction information.

In uncalibrated mode, the output protocols are triggered by the DNC (detection noise constant) in the speed path. After start up the sensor switches with the DNC min value and after that the DNC is adapted to the magnetic input signal amplitude.

The offset update starts if two valid extrema values are found and the direction of the update has the same orientation as the magnetic signal. For example, a positive offset update is being issued on a rising magnetic edge only. After a successful offset correction, the sensor is in calibrated mode. Switching occurs at the adaptive hysteresis threshold level.

In calibrated mode, the DNC is adapted to magnetic input signal amplitude with a minimum of ΔB_{limit} . The output pulses are then triggered with adaptive hysteresis.

1.5 Hysteresis Concept

The adaptive hysteresis is linked to the input signal. Therefore, the system is able to suppress switching if vibration or noise signals are smaller than the adaptive hysteresis levels. The typical value for the hysteresis level is 1/4 of the magnetic input signal amplitude, the minimum hysteresis level is ΔB_{limit} .

The visible hysteresis keeps the excellent performance in large pitch transmission application wheels.

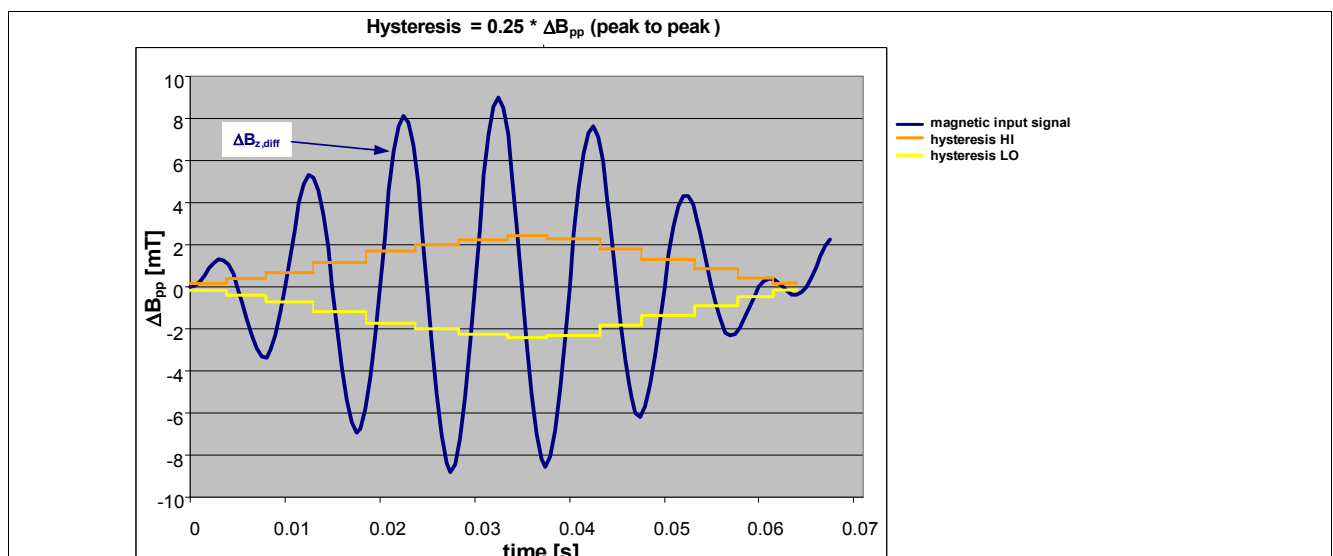

Figure 4 Adaptive Hysteresis

Functional Description

1.6 Rotational Direction

The direction signal is digitized by an analog to digital converter (direction ADC) and fed into the digital core. Depending upon the rotation direction of the target wheel, the signal of the center probe anticipates or lags behind for 90°. This phase relationship is evaluated and converted into rotation direction information by sampling the signal of the center probe in the proximity of the zero crossing of the “speed” bridge signal.

The first pulse after power has a different length to signalize that there is no direction information available.

1.7 Vibration Suppression

The magnetic signal amplitude and the direction information are used for detection of parasitic magnetic signals. Unwanted magnetic signal can be caused by angular or air gap vibrations. If an input signal is identified as a vibration the output pulse will be suppressed.

General Characteristics

2 General Characteristics

2.1 Absolute Maximum Ratings

Table 2 Absolute Maximum Ratings

Parameter	Symbol	Values			Unit	Note or Test Condition
		Min.	Typ.	Max.		
Supply voltage without supply resistor	V_{DD}	-16	–	18	V	continuous, $T_J \leq 175^\circ\text{C}$
				27	V	max. 60 s, $T_J \leq 175^\circ\text{C}$
		-18			V	max. 60 s, $T_J \leq 175^\circ\text{C}$
Output OFF voltage	V_{Q_OFF}	-1.0	–		V	max. 1 h, $T_{Amb} \leq 40^\circ\text{C}$
		-0.3	–	26.5	V	continuous, $T_J \leq 175^\circ\text{C}$
Output ON voltage	V_{Q_ON}	–	–	16	V	continuous, $T_{Amb} \leq 40^\circ\text{C}$
		–	–	18	V	max. 1 h, $T_{Amb} \leq 40^\circ\text{C}$
		–	–	26.5	V	max. 60 s, $T_{Amb} \leq 40^\circ\text{C}$
Junction temperature range	T_J	-40	–	185	$^\circ\text{C}$	exposure time: max. 10×1 h, $V_{DD} = 16\text{V}$
Magnetic field induction	B_Z	-5	–	5	T	magnetic pulse during magnet magnetization; valid 10 s with $T_{ambient} \leq 80^\circ\text{C}$
ESD compliance	ESD_{HBM}	-2	–	2	kV	HBM ¹⁾

1) ESD susceptibility, HBM according to EIA/JESD 22-A114B

Note: Stresses above the max values listed here may cause permanent damage to the device. Exposure to absolute maximum rating conditions for extended periods may affect device reliability. Maximum ratings are absolute ratings; exceeding only one of these values may cause irreversible damage to the integrated circuit.

General Characteristics

2.2 Operating Range

All parameters specified in the following sections refer to these operating conditions unless otherwise specified.

Table 3 General Operating Conditions

Parameter	Symbol	Values			Unit	Note or Test Condition
		Min.	Typ.	Max.		
Supply voltage without supply resistance R_s	V_{DD}	4.0	-	16	V	
Continuous Output Off voltage	V_{Q_OFF}	-	-	16	V	
Supply voltage power- up/down voltage ramp	dV_{DD}/dt	3.0	-	1e4	V/ms	
Supply current	I_{DD}	8.0	-	13.4	mA	
Continuous output On current	I_{Q_ON}		-	15	mA	$V_{Q_LOW} < 0.5 V$
Magnetic signal frequency range	f	0	-	10	kHz	
Frequency range for direction detection (hysteresis) once high speed has been selected	f_{Dir}	0		4.3	kHz	increasing rotational frequency
		0		4	kHz	decreasing rotational frequency
Maximum number of EEPROM programming cycles	N_{PROG}			100	n	
Dynamic range of the magnetic field of the differential speed channel	$DR_{mag_field_s}$	-120	-	120	mT	
Dynamic range of the magnetic field of the direction channel	$DR_{mag_field_dir}$	-60	-	60	mT	
Static range of the magnetic field of the outer Hall probes	$SR_{mag_field_s}$	0	-	550	mT	
Static range of the magnetic field of the center Hall probe	$DR_{mag_field_dir}$	-100	-	450	mT	
Allowed static difference between outer probes	$SR_{mag_field_diff}$	-30	-	30	mT	
Normal operating junction temperature	T_J	-40	-	175	°C	exposure time: max. 2500 h at $T_J = 175^\circ C$, $V_{DD} = 16 V$
		-	-	185	°C	exposure time: max. $10 \times 1 h$ at $T_J = 185^\circ C$, $V_{DD} = 16 V$, additive to other lifetime
Not operational lifetime	T_{no}	-40		150	°C	without sensor function; exposure time max 500 h @ $150^\circ C$; increased time for lower temperatures according to Arrhenius-Model, additive to other lifetime

General Characteristics

Table 3 General Operating Conditions (cont'd)

Parameter	Symbol	Values			Unit	Note or Test Condition
		Min.	Typ.	Max.		
Ambient temperature range for device features reading and programming	T_{RDPROG}	15	25	130	°C	during programming at customer
Temperature compensation range of magnetic material	TC		-600		ppm	internal compensation of magnetic signal amplitude of speed signal

Note: *In the operating range the functions given in the functional description are fulfilled*

Electrical and Magnetic Characteristics

3 Electrical and Magnetic Characteristics

All values specified at constant amplitude and offset of input signal, over operating range, unless otherwise specified. Typical values correspond to $V_S = 5\text{ V}$ and $T_{Amb.} = 25^\circ\text{C}$

Table 4 Electrical and Magnetic Parameters

Parameter	Symbol	Values			Unit	Note or Test Condition
		Min.	Typ.	Max.		
Output saturation voltage	V_{Qsat}	0	-	500	mV	$I_Q \leq 15\text{ mA}$
Clamping voltage V_{DD} -Pin	V_{DD_clamp}	42		-	V	leakage current through ESD diode < 0.5mA
Clamping voltage V_Q -Pin	V_{Qclamp}	42		-	V	leakage current through ESD diode < 0.5mA
Reset voltage	V_{DD_reset}	2.8		3.6	V	
Output leakage current	I_{Qleak}	0	0.1	10	μA	$V_Q = 18\text{ V}$
Output current limit during short-circuit condition	I_{Qshort}	30	-	80	mA	
Junction temperature limit for output protection	T_{prot}	190	-	205	$^\circ\text{C}$	
Power on time	t_{power_on}	0.8	0.9	1	ms	during this time the output is locked to high.
Delay time between magnetic signal switching point and corresponding output signal falling edge switching event	t_{delay}	10	14	19	μs	
Output fall time	t_{fall}	2.0	2.5	3.0	μs	$V_{Pullup} = 5\text{ V}$, $R_{Pullup} = 1.2\text{ k}\Omega$ (+/-10%), $C_Q = 1.8\text{ nF}$ (+/-15%), valid between 80% - 20%
		3.2	4.5	5.8	μs	$V_{Pullup} = 5\text{ V}$, $R_{Pullup} = 1.2\text{ k}\Omega$ (+/-10%), $C_Q = 1.8\text{ nF}$ (+/-15%), valid between 90% - 10%
Output rise time	$t_{rise}^{1)}$	4	-	11.4	μs	$R_{Pullup} = 1.2\text{ k}\Omega$ (+/-10%), $C_Q = 1.8\text{ nF}$ (+/-15%), valid between 10% - 90%
Digital noise constant of speed channel during start up	DNC_{min}	1.22	1.5	1.78	mT	
Adaptive hysteresis threshold	$HYS_{adaptive}$		25		%	EEPROM "HYST_ADAPT"Option 0
			12.5		%	EEPROM "HYST_ADAPT"Option 1
Period Jitter, $f \leq 8\text{ kHz}^{2)}$	Jit_{8kHz}	-1	-	1	%	1 sigma, $\Delta B_{pkpk} = 3\text{mT}$
Period Jitter, $8\text{ kHz} \leq f \leq 10\text{ kHz}^{2)}$	Jit_{10kHz}	-1.1	-	1.1	%	1 sigma, $\Delta B_{pkpk} = 3\text{mT}$
Number of wrong pulses at start-up	n_{Start}	-	-	0	n	in forward rotational direction
		0	-	1	n	in backward rotational direction

Electrical and Magnetic Characteristics

Table 4 Electrical and Magnetic Parameters (cont'd)

Parameter	Symbol	Values			Unit	Note or Test Condition
		Min.	Typ.	Max.		
Global run out ³⁾	$Runout_{global, speed}$	0	–	40	%	of magnetic speed signal amplitude
		0	–	60	%	of magnetic speed signal amplitude with reduced performance on stand-still functionality
	$Runout_{global, dir}$	0	–	40	%	of magnetic direction signal amplitude
		0	–	60	%	of magnetic direction signal amplitude with reduced performance on stand-still functionality
Tooth to tooth run out (peak to peak variation on two consecutive teeth / pole-pair) ³⁾	$Runout_{tooth, speed}$	0	–	40	%	of magnetic speed signal amplitude
	$Runout_{tooth, dir}$	0	–	40	%	of magnetic direction signal amplitude

- 1) Application parameter, IC shall not increase the rise time, Values are calculated and not tested
- 2) Parameter not subject to productive test. Verified by lab characterization based on jitter-measurement > 1000 periods
- 3) Defined as 1-(amplitude_min/amplitude_max)

Note: The listed Electrical and magnetic characteristics are ensured over the operating range of the integrated circuit. Typical characteristics specify mean values expected over the production spread. If not other specified, typical characteristics apply at $T_{Amb} = 25^{\circ}C$ and $V_S = 5 V$.

3.1 Output protocols

TLE4959-5U FX provides the option to select output protocol without direction detection. As well as the following direction detection options where the direction is provided via PWM protocol.

Table 5 Option 1

Parameter	Symbol	Values			Unit	Note or Test Condition
		Min.	Typ.	Max.		
Output pulse in forward direction	t_{fwd}	38	45	52	μs	
Output pulse in backward direction	t_{bwd}	114	135	155	μs	
Power on pulse	$t_{power-on}$	153	180	207	μs	

Electrical and Magnetic Characteristics

Table 5 Option 1 (cont'd)

Parameter	Symbol	Values			Unit	Note or Test Condition
		Min.	Typ.	Max.		
Output pulse at High speed	t_{high_speed}	25.5	30	34.5	μs	pulse available after High speed option has been selected
Stand still pulse	$t_{stand-still}$	51	60	69	μs	pulse available stand still after pulse option has been selected. Pulse delivered if no relevant magnetic signal change has been detected within 50ms

Note: $V_{Pullup} = 5 V$, $RPullup = 1.2 k\Omega (+/-10\%)$, $CQ = 1.8 nF (+/-15\%)$, valid between 50% of falling edge to 50% of next rising edge

Table 6 Option 2

Parameter	Symbol	Values			Unit	Note or Test Condition
		Min.	Typ.	Max.		
Output pulse in forward direction	t_{fwd}	38	45	52	μs	
Output pulse in backward direction	t_{bwd}	153	180	207	μs	
Output pulse at High speed	$t_{stand-still}$	38	45	52	μs	pulse available after High speed option has been selected

Attention: First pulse after magnetic edge suppressed

Note: $V_{Pullup} = 5 V$, $RPullup = 1.2 k\Omega (+/-10\%)$, $CQ = 1.8 nF (+/-15\%)$, valid between 50% of falling edge to 50% of next rising edge

Table 7 Option 3

Parameter	Symbol	Values			Unit	Note or Test Condition
		Min.	Typ.	Max.		
Output pulse in forward direction	t_{fwd}	51	60	69	μs	
Output pulse in backward direction	t_{bwd}	102	120	138	μs	
Power on pulse	$t_{power-on}$	25.5	30	34.5	μs	
Output pulse at High speed	t_{high_speed}	25.5	30	34.5	μs	pulse available after High speed option has been selected

Electrical and Magnetic Characteristics

Note: $V_{Pullup} = 5\text{ V}$, $RPullup = 1.2\text{ k}\Omega$ (+/-10%), $CQ = 1.8\text{ nF}$ (+/-15%), valid between 50% of falling edge to 50% of next rising edge

Table 8 Option 4

Parameter	Symbol	Values			Unit	Note or Test Condition
		Min.	Typ.	Max.		
Output pulse in forward direction	t_{fwd}	38	45	52	μs	
Output pulse in backward direction	t_{bwd}	76.5	90	103.5	μs	
Power on pulse	$t_{power-on}$	153	180	207	μs	
Output pulse at High speed	t_{high_speed}	38	45	52	μs	pulse available after High speed option has been selected

Note: $V_{Pullup} = 5\text{ V}$, $RPullup = 1.2\text{ k}\Omega$ (+/-10%), $CQ = 1.8\text{ nF}$ (+/-15%), valid between 50% of falling edge to 50% of next rising edge

EEPROM Functional Description

4 EEPROM Functional Description

4.1 Serial Interface

The serial interface is used to set parameter and to program the sensor IC, it allows writing and reading of internal registers. Data transmission to the IC is done by supply voltage modulation, by providing the clock timing and data information via only one line. Data from the IC are delivered via the output line, triggered by as well clocking the supply line. In normal application operation the interface is not active, for entering that mode a certain command right after power-on is required.

A detailed document (TLE4959C FX EEPROM Programming Guide) is available on request. It contains the description of electrical timing and voltage requirements, as well as the information about data protocol, available registers and addresses.

4.1.1 Data Transmission

Commands to the sensor are sent by modulating the supply voltage between two levels $V_{DD,high}$ and $V_{DD,low}$. They are sent in series of 17 pulses corresponding to 16 bit words, with MSB transmitted first and LSB last, respectively the stop bit. Each of the 16 pulses is coded by the duty cycle as logical "0" or "1". Logical "1" is represented by a duty cycle of 2/3 of the period on $V_{DD,high}$, logical "0" is represented by a duty cycle of 1/3 at $V_{DD,high}$. This forms the bit information and acts also as serial interface clock. Data transmission from the device is represented by the state of the output, high for logical "1" and low for logical "0". Recommended period length is around 200 (tbd) μ s per bit.

End of word is indicated by a long "low" supply (> 750 ms, first 30 ms should be $> V_{DD,high}$, remaining time $< V_{DD,low}$). Please note, that for transmission of 16 data bits in total 17 pulses on V_{DD} are necessary. If more than 16 input bits are transmitted the output bits are irrelevant (transmission buffer empty), whereas the input bits remain valid and start overwriting the previously transmitted bits. In any case the last 17 transmitted bits are interpreted as transmitted data word (16 bit) + 1 stop bit.

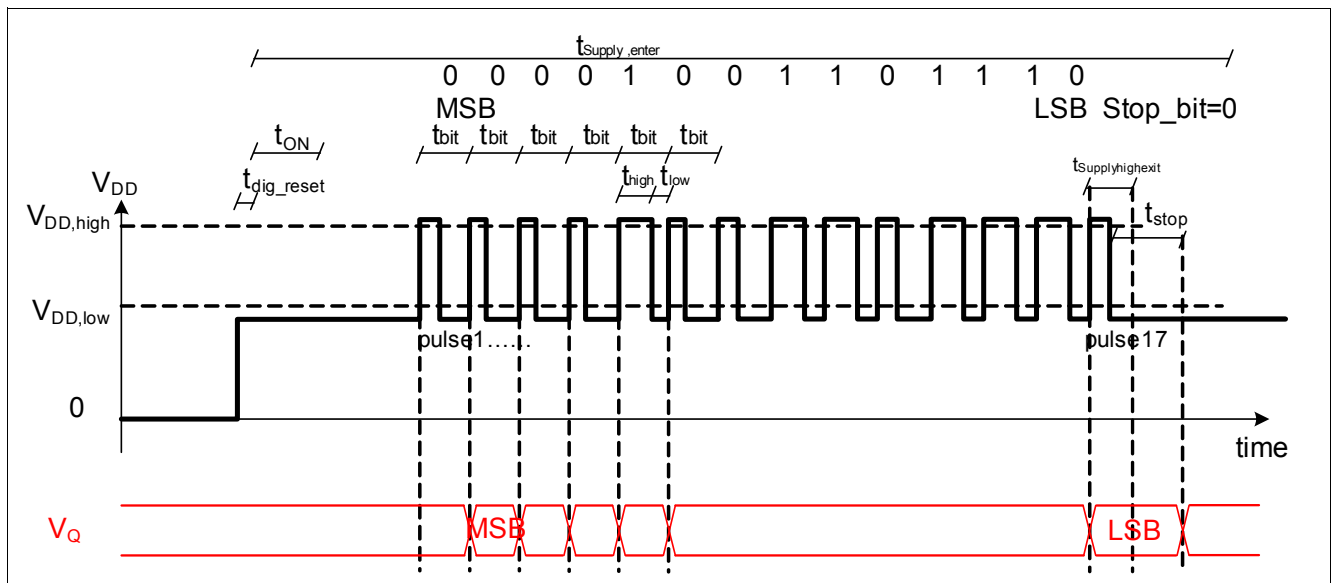

Figure 5 Serial Protocol

EEPROM Functional Description

4.2 EEPROM Description

Several options of TLE4959C FX can be programmed via an EEPROM to optimize the sensor algorithm to the individual target wheel and application requirements. The EEPROM memory is organized in 2 customer lines. Each line is composed of 16 data bits and additional 6 bits for error detection and correction, based on ECC (Error Correction Code). For more detailed information about EEPROM access and programming an additional document is available on request.

Table 9 EEPROM Address 0x0

15	14	13	12	11	10	9	8	7	6	5	4	3	2	1	0
-----------	-----------	-----------	-----------	-----------	-----------	----------	----------	----------	----------	----------	----------	----------	----------	----------	----------

Table 10 Functional Description Address 0x0

Field	Bit	Type	Description	Default value
Not used	15	r	Always read as “0”	0
Not used	14	rw	To be set to “0”	0
HIGH_SPEED	13	rw	0 = Enabled motion detection 1 = According selected protocol when above 4.3kHz	0
Not used	12	rw	To be set to “0”	0
STAND_EN	11	rw	0=disable stand-still pulse 1=enable stand-still pulse Stand still pulse is provided, if enabled, only if PW_CHIOICE=00	0
Not used	10..0	rw	To be set to “00000000000”	00000000000

Table 11 EEPROM Address 0x1

15	14	13	12	11	10	9	8	7	6	5	4	3	2	1	0
-----------	-----------	-----------	-----------	-----------	-----------	----------	----------	----------	----------	----------	----------	----------	----------	----------	----------

Table 12 Functional Description Address 0x1

Field	Bit	Type	Description	Default value
Not used	15:14	rw	To be set to “01”	01
PW_CHOICE	13:12	rw	Choice of PWM protocol for direction detection. 00 = Option 1 01 = Option 2 10 = Option 3 11 = Option 4	11
FORWARD_DEF	11	rw	0 = None inversion of forward definition 1 = Inversion of forward definition	0
EDGE_POLAR	10	rw	0 = None inversion 1 = Inversion	0
HYST_ADAPT	9	rw	0 = 25% 1 = 12.5%	1

EEPROM Functional Description

Table 12 Functional Description Address 0x1 (cont'd)

Field	Bit	Type	Description	Default value
Not used	8.. 5	rw	To be set to "1101"	1101
DNC_ADAPT	4	rw	DNC Adaption: 0 = 25% 1 = 12.5%	0
Not used	3	rw	To be set to "0"	0
DIR_ENABLE	2	rw	0 = Direction detection off 1 = Direction detection on	1
Not used	1	rw	To be set to "1"	1
LOCK	0	rw	0 = User area of EEPROM is unlocked 1 = User area of EEPROM is locked (no reprogramming possible)	0

Package Information

5 Package Information

Pure tin covering (green lead plating) is used. The product is RoHS (Restriction of Hazardous Substances) compliant and marked with letter G in front of the data code marking and may contain a data matrix code on the rear side of the package (see also information note 136/03). Please refer to your key account team or regional sales if you need further information.

The specification for soldering and welding is defined in the latest revision of application note “Recommendation for Board Assembly-Hallsensor SSO Packages”.

5.1 Package Outline

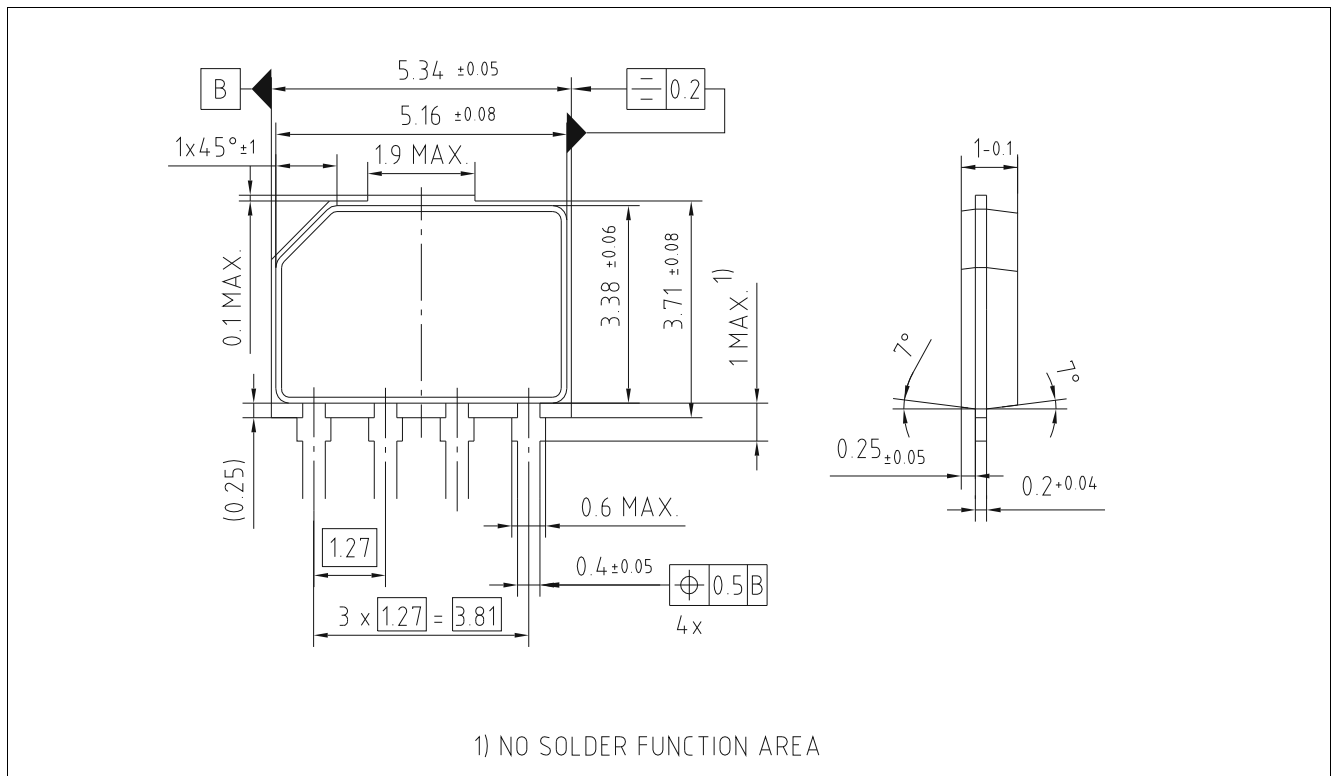

Figure 6 PG-SSO-4-1 (Plastic Green Single Slim Outline), Package Dimensions

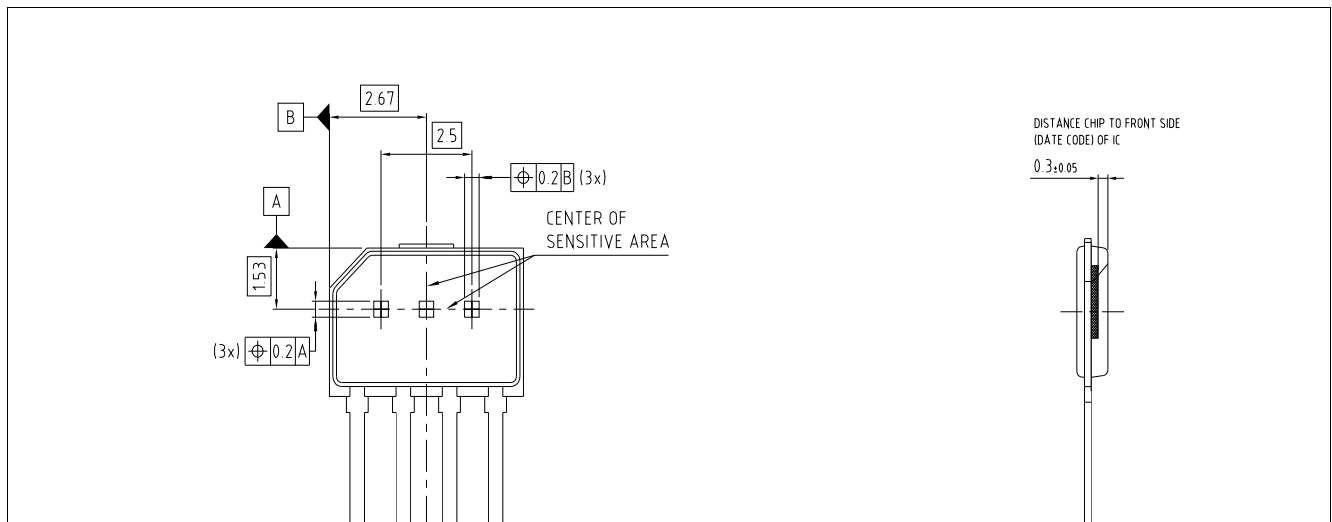

Figure 7 Position of the Hall Elements and distance to the branded Side

Package Information

5.2 Marking and Data Matrix Code

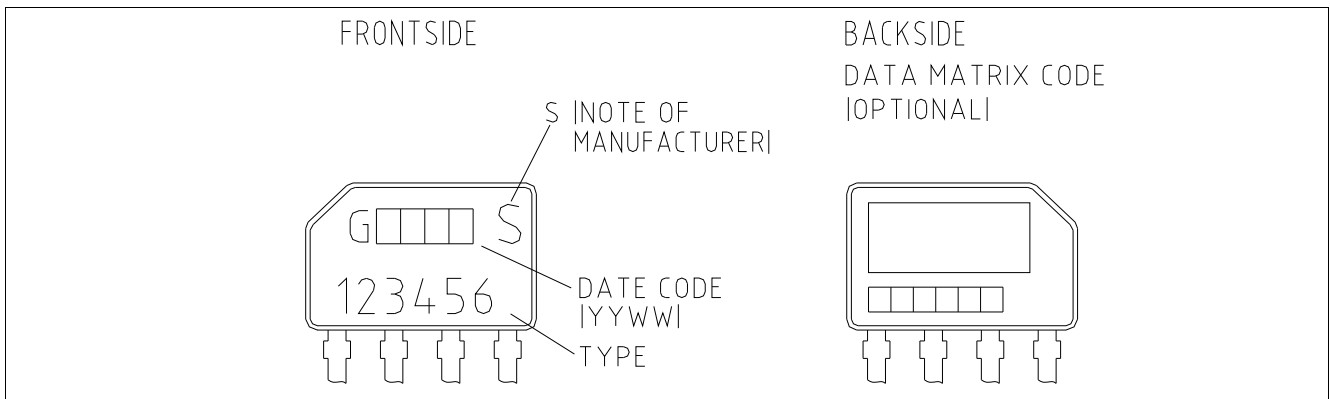

Figure 8 Marking of PG-SSO-4-1 Package

Table 13 Pin Description

Pin Number ¹⁾	Symbol	Function
1	V_{DD}	Supply Voltage
2	GND	Ground
3	GND	Ground
4	Q	Open Drain Output

1) Refer to frontside view: leftmost pin corresponding to pin number 1

Package Information

5.3 Packing Information

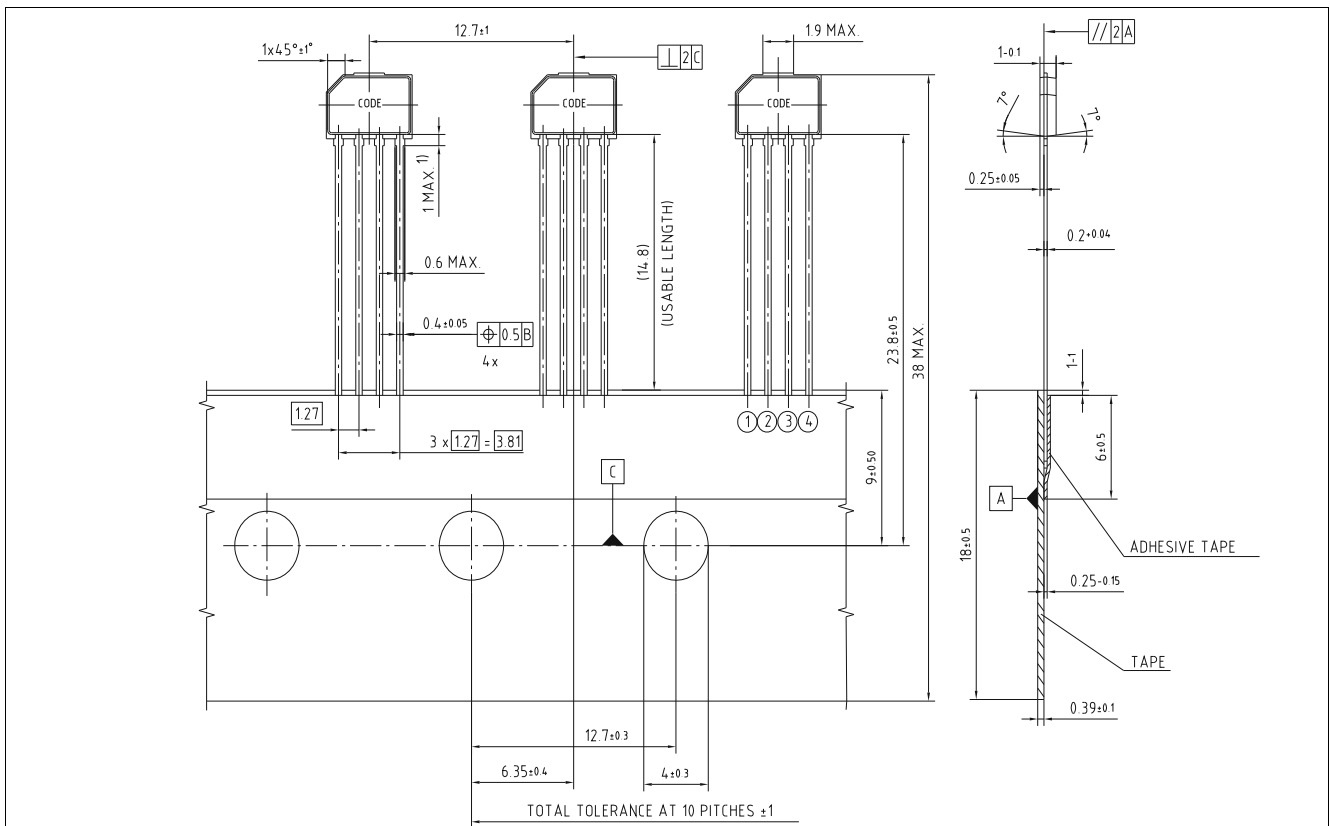

Figure 9 PG-SSO-4-1 Ammopack



Revision History

6 Revision History

Revision	Date	Changes
1.0	2018-07	First released version of Datasheet

Trademarks of Infineon Technologies AG

μ HVIC™, μ IPM™, μ PFC™, AU-ConvertIR™, AURIX™, C166™, CanPAK™, CIPOS™, CIPURSE™, CoolDP™, CoolGaN™, COOLiR™, CoolMOS™, CoolSET™, CoolSiC™, DAVE™, DI-POL™, DirectFET™, DrBlade™, EasyPIM™, EconoBRIDGE™, EconoDUAL™, EconoPACK™, EconoPIM™, EiceDRIVER™, eupec™, FCOS™, GaNpowIR™, HEXFET™, HITFET™, HybridPACK™, iMOTION™, IRAM™, ISOFACE™, IsoPACK™, LEDriviR™, LITIX™, MIPAQ™, ModSTACK™, my-d™, NovalithIC™, OPTIGA™, OptiMOS™, ORIGA™, PowIRaudio™, PowIRstage™, PrimePACK™, PrimeSTACK™, PROFET™, PRO-SIL™, RASIC™, REAL3™, SmartLEWIS™, SOLID FLASH™, SPOC™, StrongIRFET™, SupIRBuck™, TEMPFET™, TRENCHSTOP™, TriCore™, UHVIC™, XHP™, XMC™.

Trademarks updated November 2015

Other Trademarks

All referenced product or service names and trademarks are the property of their respective owners.

Edition 2018-07

Published by

Infineon Technologies AG

81726 Munich, Germany

© 2018 Infineon Technologies AG.

All Rights Reserved.

Do you have a question about any aspect of this document?

Email: erratum@infineon.com

IMPORTANT NOTICE

The information given in this document shall in no event be regarded as a guarantee of conditions or characteristics ("Beschaffheitsgarantie").

With respect to any examples, hints or any typical values stated herein and/or any information regarding the application of the product, Infineon Technologies hereby disclaims any and all warranties and liabilities of any kind, including without limitation warranties of non-infringement of intellectual property rights of any third party.

In addition, any information given in this document is subject to customer's compliance with its obligations stated in this document and any applicable legal requirements, norms and standards concerning customer's products and any use of the product of Infineon Technologies in customer's applications.

The data contained in this document is exclusively intended for technically trained staff. It is the responsibility of customer's technical departments to evaluate the suitability of the product for the intended application and the completeness of the product information given in this document with respect to such application.

For further information on technology, delivery terms and conditions and prices, please contact the nearest Infineon Technologies Office (www.infineon.com).

WARNINGS

Due to technical requirements products may contain dangerous substances. For information on the types in question please contact your nearest Infineon Technologies office.

Except as otherwise explicitly approved by Infineon Technologies in a written document signed by authorized representatives of Infineon Technologies, Infineon Technologies' products may not be used in any applications where a failure of the product or any consequences of the use thereof can reasonably be expected to result in personal injury.