

Series 18  
*Streamlined. Compact and tactile.*

<https://eao.com/18>



# 18 Information about the Series

## Key advantages

- Excellent tactile feedback when switching
- Gold-plated silver contacts available for low voltages and currents
- Bright, homogenous illumination
- Compact construction
- Can be mounted on PCBs
- Raised 8mm or flush 16mm mounting

## Typical application areas

- Audio / video
- Measurement technology
- Medical engineering

## Functions

- Pushbutton
- Illuminated pushbutton
- Indicator

## Design

- Flush
- Raised

## IP front protection

- IP40

## Rating

- 42 VAC (100 mA)

## Mounting cut-outs

- Ø 8 mm
- Ø 16 mm
- Square

## Terminal

- Soldering terminal
- PCB (with PCB plug-in base)

## Lens Material

- Plastic

## Markings

- Engraving
- Laser marking

## Approvals

- No approvals

## Conformities

- CE
- 2011/65/EU (RoHS)



<b>Flush design</b>		
Pushbutton square	368	01
Pushbutton round	370	02
Illuminated pushbutton square	372	03
Illuminated pushbutton round	374	04
Indicator square	376	09
Indicator	378	14
<b>Raised design</b>		
Pushbutton square	380	17
Pushbutton rectangular	382	18
Pushbutton round	384	19
Illuminated pushbutton square	386	22
Illuminated pushbutton rectangular	388	31
Illuminated pushbutton round	390	41
Indicator square	392	45
Indicator rectangular	394	51
Indicator round	396	56
<b>Components</b>	398	57
<b>Accessories</b>	401	61
<b>Technical data</b>	404	70
<b>Application guidelines</b>	405	71

# 18 Flush design

## Pushbutton square, IP40



Product can differ from the current configuration.

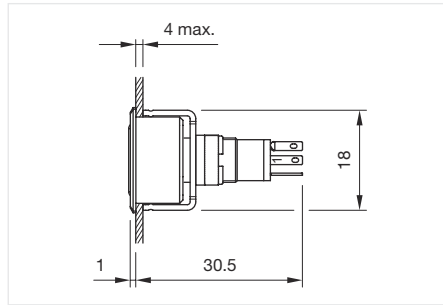

Dimensions [mm]

### General information

- +/- terminals are not connected

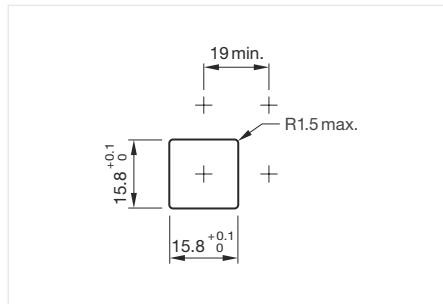

Mounting cut-outs [mm]

### Equipment consisting of (schematic overview)

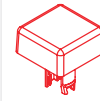

Lens

Page 398

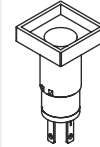

Actuator

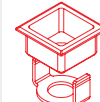

Front bezel set

Page 400



Fixing nut

Each Part Number listed below includes all the black components shown in the 3D-drawing.

To obtain a complete unit, please select the red components from the pages shown.



Actuator, Front dimension 19 mm x 19 mm

Switching action	Contacts	Terminal	Part No.	Wiring diagram	Component Layout
Momentary	1 NO	Soldering terminal	18-187.035	133	7
	1 NC	Soldering terminal	18-188.035	131	7
Maintained	1 NO	Soldering terminal	18-287.035	134	7
	1 NC	Soldering terminal	18-288.035	132	7

Contacts: NC = Normally closed, NO = Normally open

### Wiring diagrams

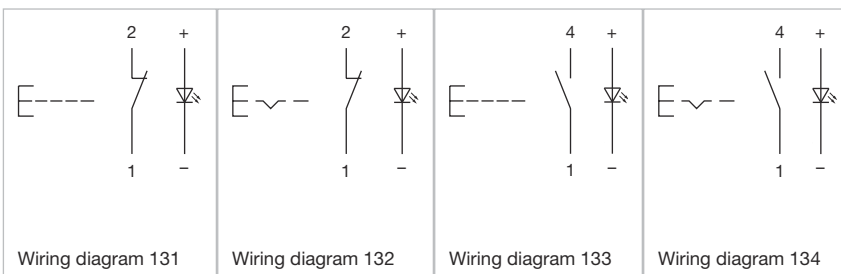

## Component layouts

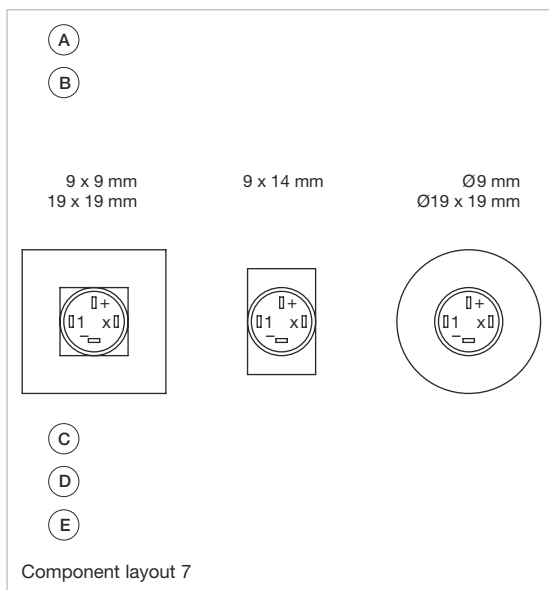

- A = Terminals (rear side)
- B = Illuminated pushbutton
- C = x = Contact No.
- D = 2 = Normally open
- E = 4 = Normally close

01
02
03
04
09
14
17
<b>18</b>
19
22
31
41
45
51
56
57
61
70
71
82
84
92
96

# 18 Flush design

## Pushbutton round, IP40

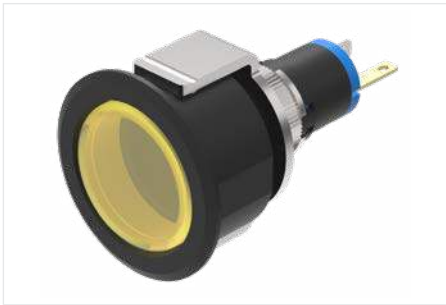

Product can differ from the current configuration.

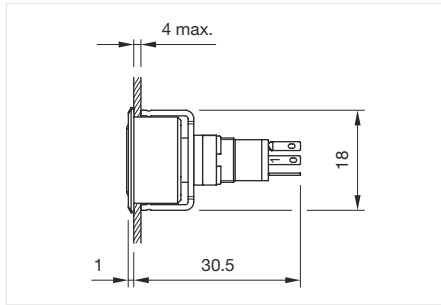

Dimensions [mm]

### General information

- +/- terminals are not connected

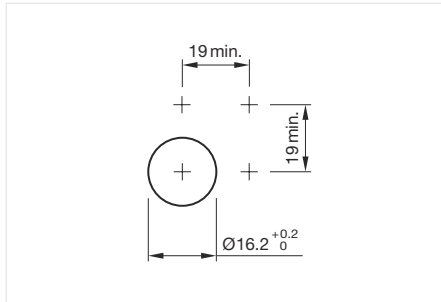

Mounting cut-outs [mm]

### Equipment consisting of (schematic overview)



Lens

Page 398

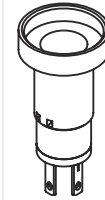

Actuator

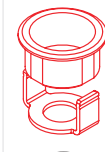

Front bezel set

Page 400



Fixing nut

Each Part Number listed below includes all the black components shown in the 3D-drawing.

To obtain a complete unit, please select the red components from the pages shown.



Actuator, Front dimension Ø 19 mm

Switching action	Contacts	Terminal	Part No.	Wiring diagram	Component Layout
Momentary	1 NO	Soldering terminal	18-167.035	133	7
	1 NC	Soldering terminal	18-168.035	131	7
Maintained	1 NO	Soldering terminal	18-267.035	134	7
	1 NC	Soldering terminal	18-268.035	132	7

Contacts: NC = Normally closed, NO = Normally open

## Wiring diagrams

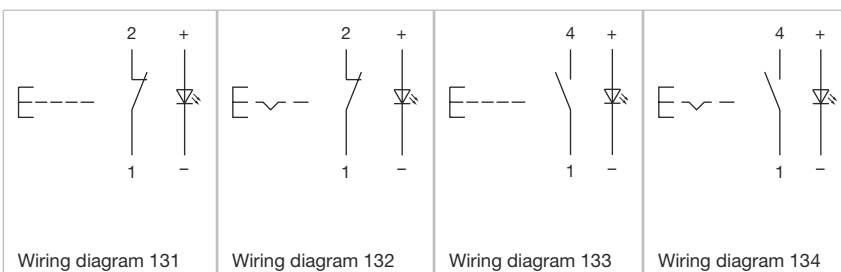

## Component layouts

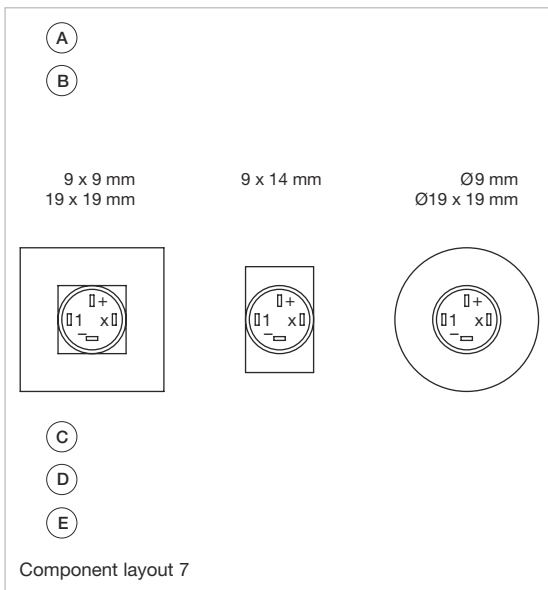

- A = Terminals (rear side)
- B = Illuminated pushbutton
- C = x = Contact No.
- D = 2 = Normally open
- E = 4 = Normally close

- 01
- 02
- 03
- 04
- 09
- 14
- 17
- 18**
- 19
- 22
- 31
- 41
- 45
- 51
- 56
- 57
- 61
- 70
- 71
- 82
- 84
- 92
- 96

# 18 Flush design

## Illuminated pushbutton square, IP40



Product can differ from the current configuration.

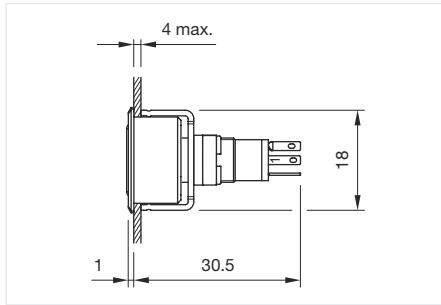

Dimensions [mm]

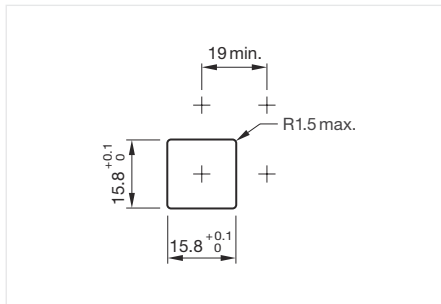

Mounting cut-outs [mm]

### Equipment consisting of (schematic overview)

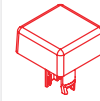

Lens

Page 398

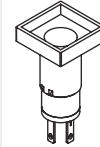

Actuator

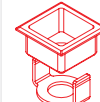

Front bezel set

Page 400



Fixing nut

Each Part Number listed below includes all the black components shown in the 3D-drawing.

To obtain a complete unit, please select the red components from the pages shown.



Actuator, Front dimension 19 mm x 19 mm

Switching action	Contacts	Terminal	Part No.	Wiring diagram	Component Layout
Momentary	1 NO	Soldering terminal	18-187.035	133	7
	1 NC	Soldering terminal	18-188.035	131	7
Maintained	1 NO	Soldering terminal	18-287.035	134	7
	1 NC	Soldering terminal	18-288.035	132	7

Contacts: NC = Normally closed, NO = Normally open

### Wiring diagrams

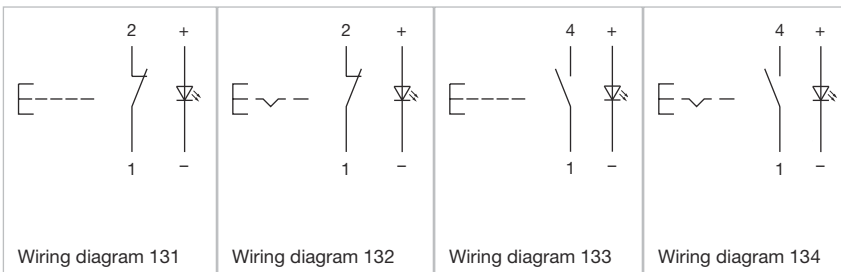



## Component layouts

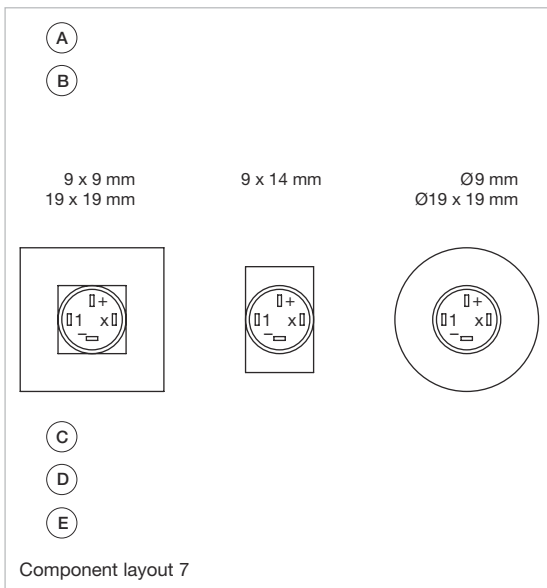

- A = Terminals (rear side)
- B = Illuminated pushbutton
- C = x = Contact No.
- D = 2 = Normally open
- E = 4 = Normally close



Tactile, compact and bright.  
*EAO Series 18.*

Especially well-suited as controls and indicators – thanks to the tactile feedback and the outstanding illumination.

- Excellent tactile feedback
- Outstanding illumination
- Long service life
- Gold-plated nickel contacts
- Flush and raised variants
- Compact design

[www.eao.com/18](http://www.eao.com/18)

**eao** ■

Your Expert Partner for Human Machine Interfaces

# 18 Flush design

## Illuminated pushbutton round, IP40



Product can differ from the current configuration.

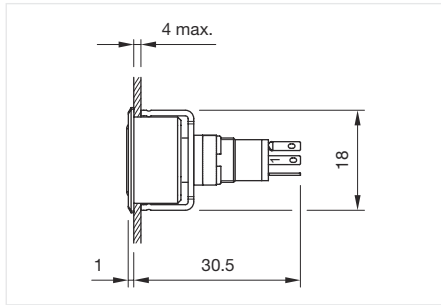

Dimensions [mm]

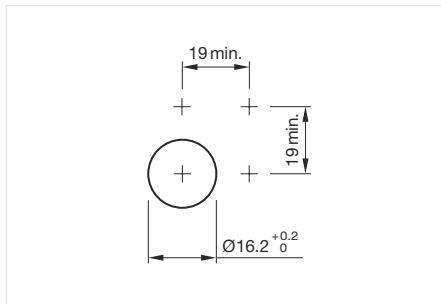

Mounting cut-outs [mm]

### Equipment consisting of (schematic overview)



Lens

Page 398

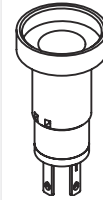

Actuator



Front bezel set

Page 400



Fixing nut

Each Part Number listed below includes all the black components shown in the 3D-drawing.

To obtain a complete unit, please select the red components from the pages shown.



Actuator, Front dimension Ø 19 mm

Switching action	Contacts	Terminal	Part No.	Wiring diagram	Component Layout
Momentary	1 NO	Soldering terminal	18-167.035	133	7
	1 NC	Soldering terminal	18-168.035	131	7
Maintained	1 NO	Soldering terminal	18-267.035	134	7
	1 NC	Soldering terminal	18-268.035	132	7

Contacts: NC = Normally closed, NO = Normally open

### Wiring diagrams

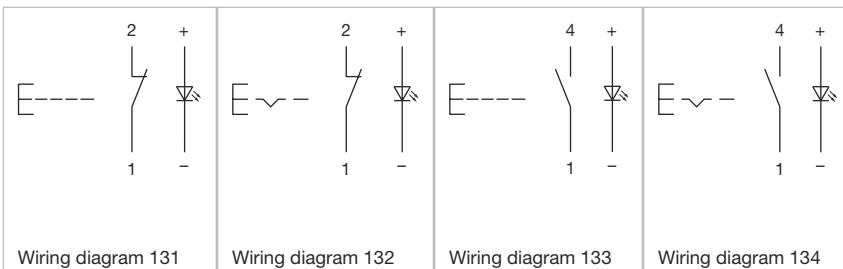

## Component layouts

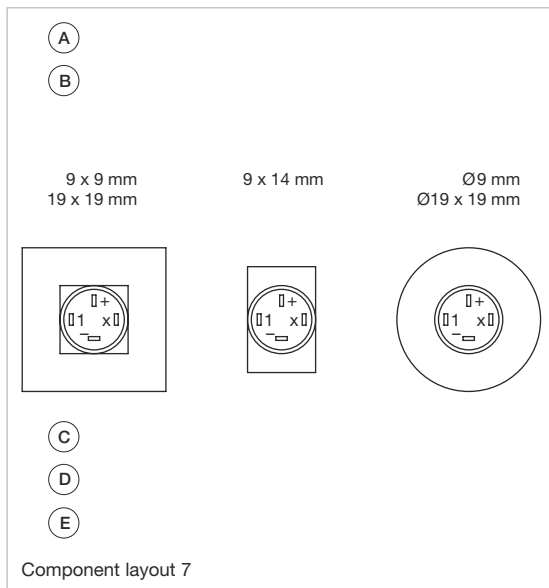

- A = Terminals (rear side)
- B = Illuminated pushbutton
- C = x = Contact No.
- D = 2 = Normally open
- E = 4 = Normally close

- 01
- 02
- 03
- 04
- 09
- 14
- 17
- 18**
- 19
- 22
- 31
- 41
- 45
- 51
- 56
- 57
- 61
- 70
- 71
- 82
- 84
- 92
- 96

# 18 Flush design

## Indicator square, IP40



Product can differ from the current configuration.

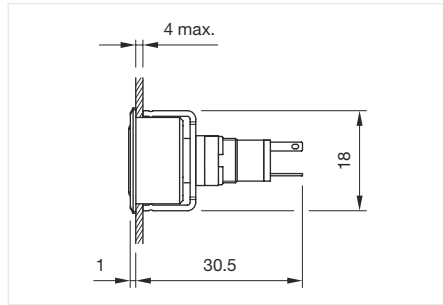

Dimensions [mm]

### General information

- Luminosity and wave length variations caused by LED manufacturing processes may cause slight differences regarding the illumination. The customer has to decide what resistor shall be used to the LED
- The customer has to decide what series resistor shall be used to the LED

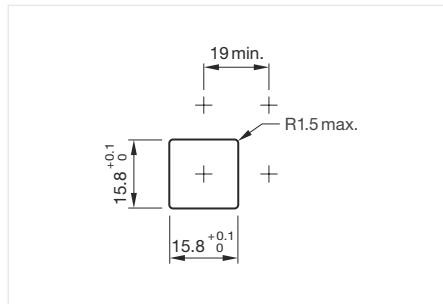

Mounting cut-outs [mm]

### Equipment consisting of (schematic overview)

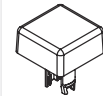

Lens

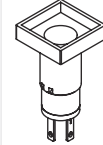

Actuator

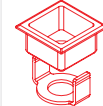

Front bezel set

Page 400



Fixing nut

Each Part Number listed below includes all the black components shown in the 3D-drawing.

To obtain a complete unit, please select the red components from the pages shown.



Actuator, Front dimension 19 mm x 19 mm

Operating voltage	Illumination colour	Lens colour	Lens shape	Terminal	Part No.	Wiring diagram	Component Layout
Customer specific	Red	Red	flush	Soldering terminal	18-080.0052L	130	6
	White	Yellow	flush	Soldering terminal	18-080.0054L	130	6
	Green	Green	flush	Soldering terminal	18-080.0055L	130	6
12 V DC $\pm 10\%$	Red	Red	flush	Soldering terminal	18-081.0052L	440	6
24 V DC $\pm 10\%$	Red	Red	flush	Soldering terminal	18-082.0052L	440	6
	Yellow	Yellow	flush	Soldering terminal	18-082.0054L	440	6
	Green	Green	flush	Soldering terminal	18-082.0055L	440	6

## Wiring diagrams

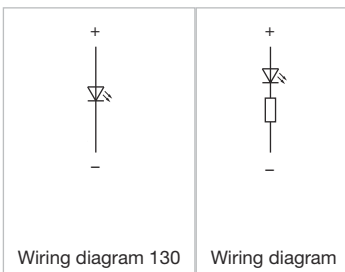

## Component layouts

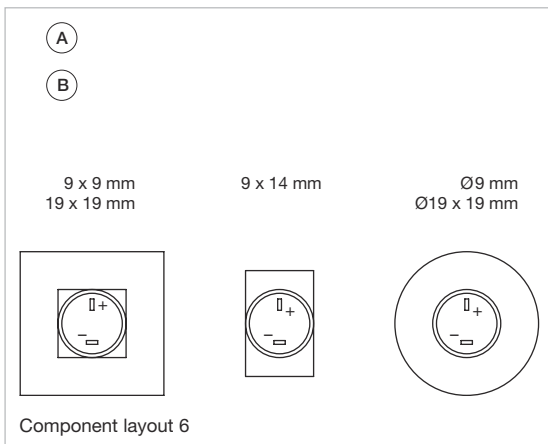

A = Terminals (rear side)  
 B = Indicator

- 01
- 02
- 03
- 04
- 09
- 14
- 17
- 18**
- 19
- 22
- 31
- 41
- 45
- 51
- 56
- 57
- 61
- 70
- 71
- 82
- 84
- 92
- 96

# 18 Flush design

## Indicator, IP40



Product can differ from the current configuration.

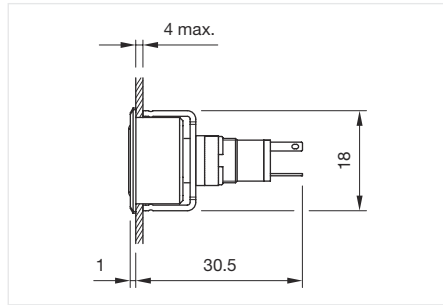

Dimensions [mm]

### General information

- Luminosity and wave length variations caused by LED manufacturing processes may cause slight differences regarding the illumination. The customer has to decide what resistor shall be used to the LED
- The customer has to decide what series resistor shall be used to the LED

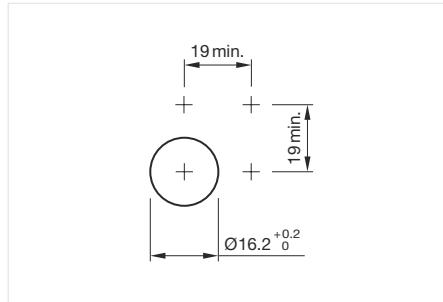

Mounting cut-outs [mm]

### Equipment consisting of (schematic overview)

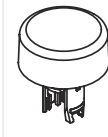

Lens

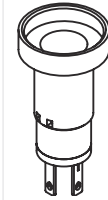

Actuator

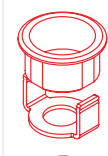

Front bezel set

Page 400



Fixing nut

Each Part Number listed below includes all the black components shown in the 3D-drawing.

To obtain a complete unit, please select the red components from the pages shown.



### Actuator, Front dimension Ø 19 mm

Operating voltage	Illumination colour	Lens colour	Lens shape	Terminal	Part No.	Wiring diagram	Component Layout
Customer specific	Red	Red	flush	Soldering terminal	18-060.0052L	130	6
	White	Yellow	flush	Soldering terminal	18-060.0054L	130	6
	Green	Green	flush	Soldering terminal	18-060.0055L	130	6
12 V DC ±10 %	Red	Red	flush	Soldering terminal	18-061.0052L	440	6
	Yellow	Yellow	flush	Soldering terminal	18-061.0054L	440	6
	Green	Green	flush	Soldering terminal	18-061.0055L	440	6
24 V DC ±10 %	Red	Red	flush	Soldering terminal	18-062.0052L	440	6
	Yellow	Yellow	flush	Soldering terminal	18-062.0054L	440	6
	Green	Green	flush	Soldering terminal	18-062.0055L	440	6

## Wiring diagrams

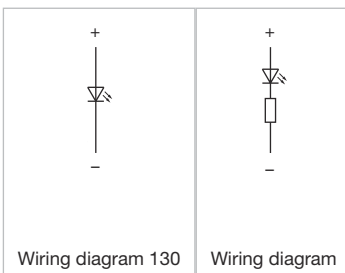

Wiring diagram 130

Wiring diagram

## Component layouts

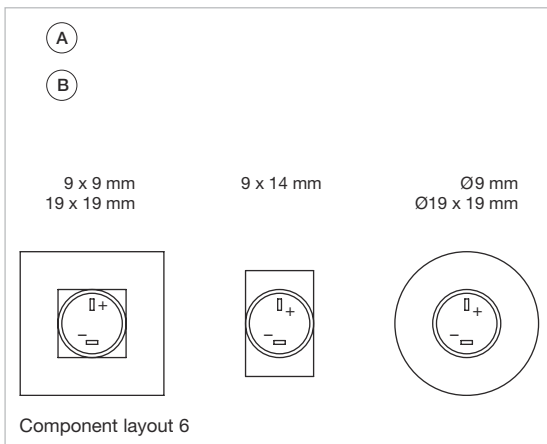

A = Terminals (rear side)  
B = Indicator



### Taktil, kompakt und lichtstark. *EAO Baureihe 18.*

Prädestiniert für Steuerungen und Statusanzeigen – dank des taktilen Schaltgefühls und einer lichtstarken Ausleuchtung.

- Hervorragendes, taktiler Schaltgefühl
- Ausgezeichnete Ausleuchtung
- Lange Lebensdauer
- Goldplattierte Nickelkontakte
- Flache und erhabene Versionen
- Kompaktes Design

[www.eao.com/18](http://www.eao.com/18)

**eao** ■

Your Expert Partner for Human Machine Interfaces

# 18 Raised design

## Pushbutton square, IP40



Product can differ from the current configuration.

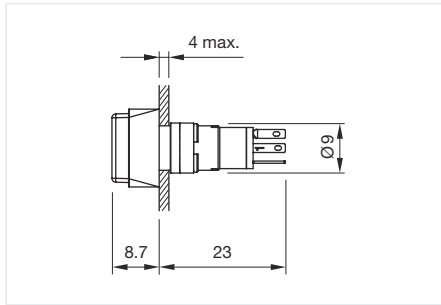

Dimensions [mm]

### General information

- +/- terminals are not connected

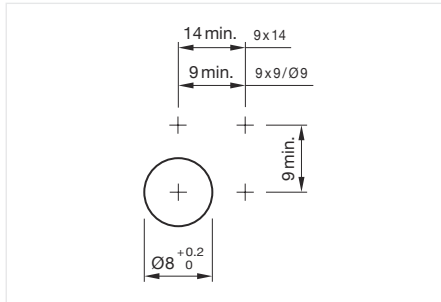

Mounting cut-outs [mm]

### Equipment consisting of (schematic overview)



Lens

Page 398

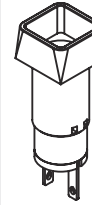

Actuator



Fixing nut

Each Part Number listed below includes all the black components shown in the 3D-drawing.

To obtain a complete unit, please select the red components from the pages shown.



### Actuator, Front dimension 9 mm x 9 mm

Switching action	Contacts	Terminal	Part No.	Wiring diagram	Component Layout
Momentary	1 NO	Soldering terminal	18-157.035	133	7
	1 NC	Soldering terminal	18-158.035	131	7
Maintained	1 NO	Soldering terminal	18-257.035	134	7
	1 NC	Soldering terminal	18-258.035	132	7

Contacts: NC = Normally closed, NO = Normally open

### Wiring diagrams

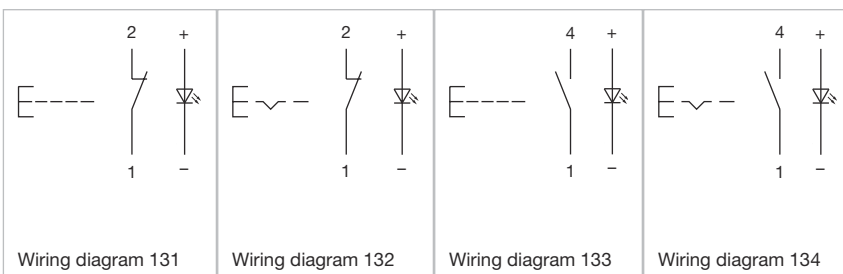



## Component layouts

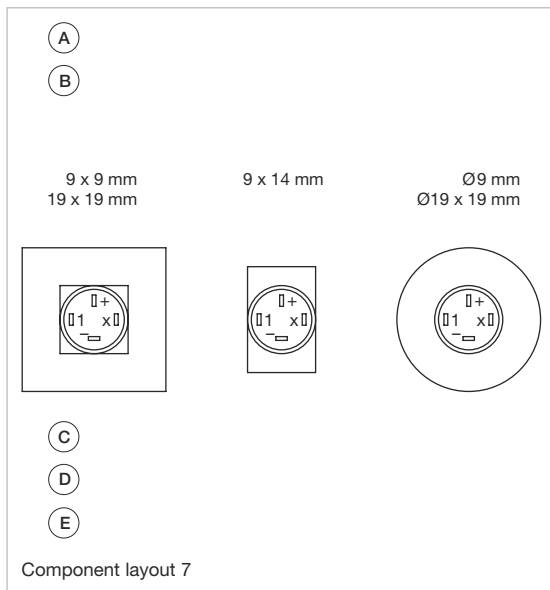

- A = Terminals (rear side)
- B = Illuminated pushbutton
- C = x = Contact No.
- D = 2 = Normally open
- E = 4 = Normally close

- 01
- 02
- 03
- 04
- 09
- 14
- 17
- 18**
- 19
- 22
- 31
- 41
- 45
- 51
- 56
- 57
- 61
- 70
- 71
- 82
- 84
- 92
- 96

# 18 Raised design

## Pushbutton rectangular, IP40



Product can differ from the current configuration.

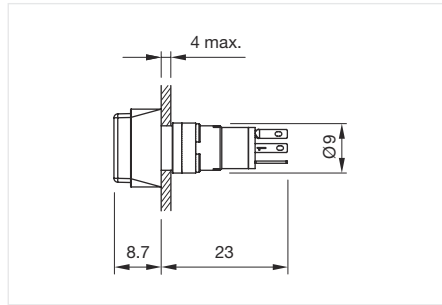

Dimensions [mm]

### General information

- +/- terminals are not connected

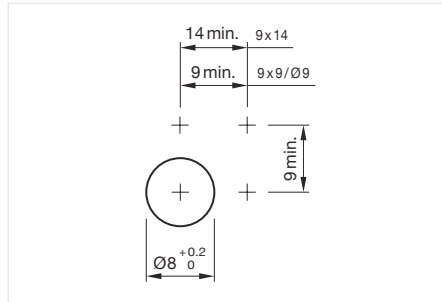

Mounting cut-outs [mm]

### Equipment consisting of (schematic overview)

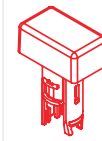

Lens

Page 398

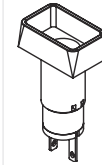

Actuator



Fixing nut

Each Part Number listed below includes all the black components shown in the 3D-drawing.

To obtain a complete unit, please select the red components from the pages shown.



Actuator, Front dimension 14 mm x 9 mm

Switching action	Contacts	Terminal	Part No.	Wiring diagram	Component Layout
Momentary	1 NO	Soldering terminal	18-147.035	133	7
	1 NC	Soldering terminal	18-148.035	131	7
Maintained	1 NO	Soldering terminal	18-247.035	134	7
	1 NC	Soldering terminal	18-248.035	132	7

Contacts: NC = Normally closed, NO = Normally open

### Wiring diagrams

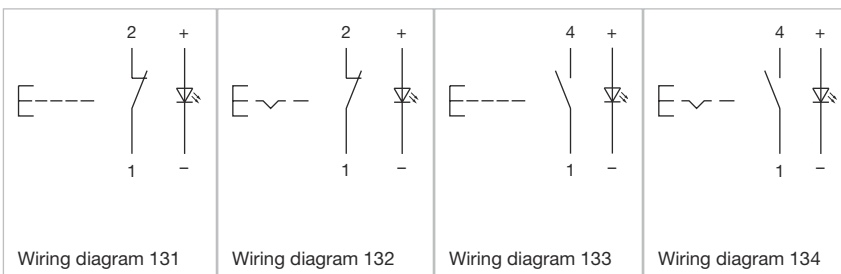

## Component layouts

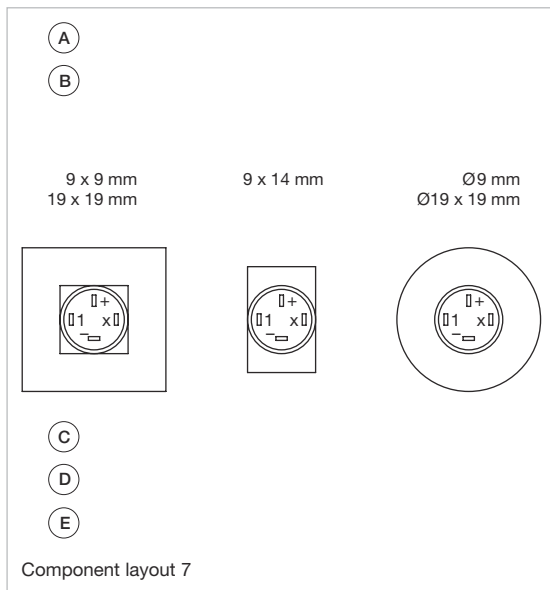

- A = Terminals (rear side)
- B = Illuminated pushbutton
- C = x = Contact No.
- D = 2 = Normally open
- E = 4 = Normally close

- 01
- 02
- 03
- 04
- 09
- 14
- 17
- 18**
- 19
- 22
- 31
- 41
- 45
- 51
- 56
- 57
- 61
- 70
- 71
- 82
- 84
- 92
- 96

# 18 Raised design

## Pushbutton round, IP40



Product can differ from the current configuration.

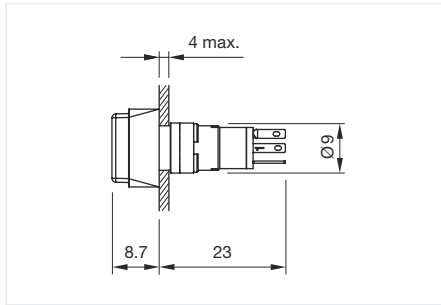

Dimensions [mm]

### General information

- +/- terminals are not connected

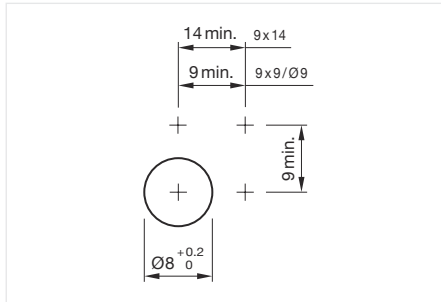

Mounting cut-outs [mm]

### Equipment consisting of (schematic overview)



Lens

Page 398



Actuator



Fixing nut

Each Part Number listed below includes all the black components shown in the 3D-drawing.

To obtain a complete unit, please select the red components from the pages shown.



### Actuator, Front dimension Ø 9 mm

Switching action	Contacts	Terminal	Part No.	Wiring diagram	Component Layout
Momentary	1 NO	Soldering terminal	18-137.035	133	7
	1 NC	Soldering terminal	18-138.035	131	7
Maintained	1 NO	Soldering terminal	18-237.035	134	7
	1 NC	Soldering terminal	18-238.035	132	7

Contacts: NC = Normally closed, NO = Normally open

### Wiring diagrams

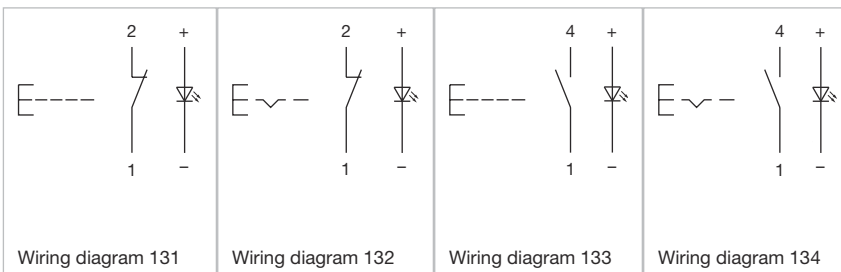

## Component layouts

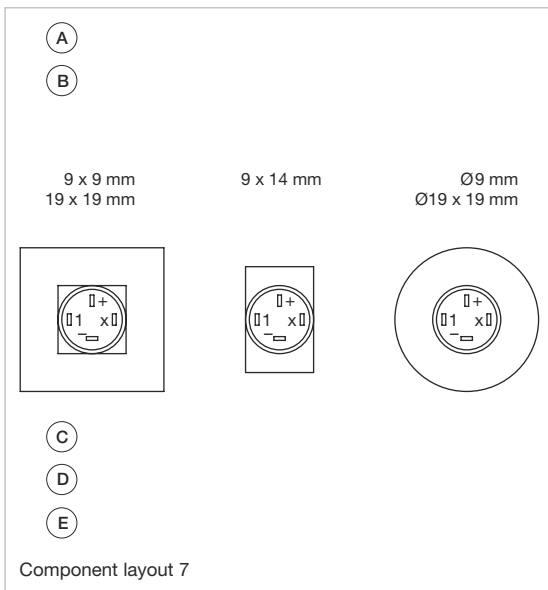



- A = Terminals (rear side)
- B = Illuminated pushbutton
- C = x = Contact No.
- D = 2 = Normally open
- E = 4 = Normally close

- 01
- 02
- 03
- 04
- 09
- 14
- 17
- 18
- 19
- 22
- 31
- 41
- 45
- 51
- 56
- 57
- 61
- 70
- 71
- 82
- 84
- 92
- 96



Follow us.  
We are on LinkedIn!  
*EAO creates possibilities. Since 1947.*





**[Come take a look at our LinkedIn profile today!](https://www.linkedin.com/company/eao/)** *Be sure to give us a follow so that you can fully interact with us.*

<https://www.linkedin.com/company/eao/>

[www.eao.com](http://www.eao.com)



Your Expert Partner for Human Machine Interfaces

# 18 Raised design

## Illuminated pushbutton square, IP40



Product can differ from the current configuration.

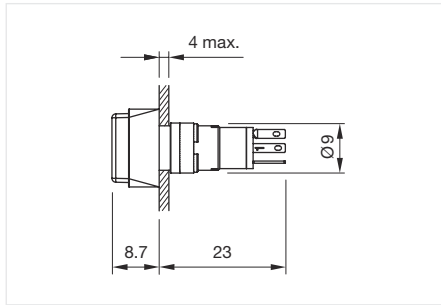

Dimensions [mm]

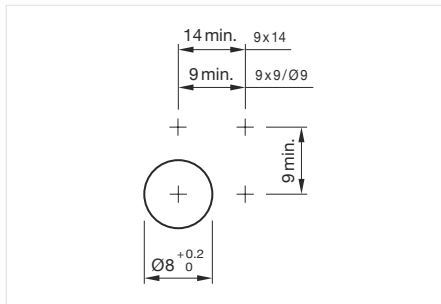

Mounting cut-outs [mm]

### Equipment consisting of (schematic overview)



Lens

Page 398



Actuator



Fixing nut

Each Part Number listed below includes all the black components shown in the 3D-drawing.

To obtain a complete unit, please select the red components from the pages shown.



Actuator, Front dimension 9 mm x 9 mm

Switching action	Contacts	Terminal	Part No.	Wiring diagram	Component Layout
Momentary	1 NO	Soldering terminal	18-157.035	133	7
	1 NC	Soldering terminal	18-158.035	131	7
Maintained	1 NO	Soldering terminal	18-257.035	134	7
	1 NC	Soldering terminal	18-258.035	132	7

Contacts: NC = Normally closed, NO = Normally open

### Wiring diagrams

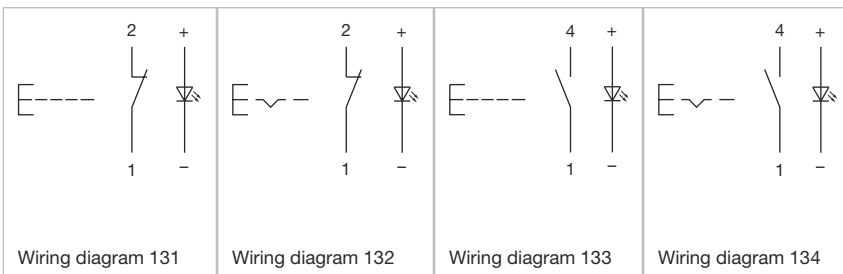

## Component layouts

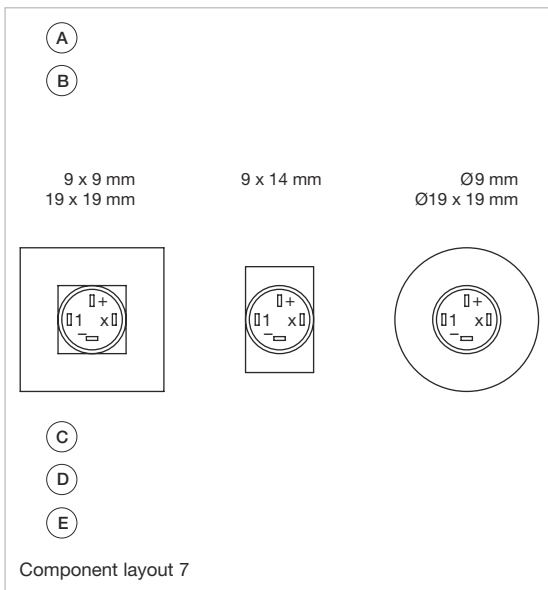

- A = Terminals (rear side)
- B = Illuminated pushbutton
- C = x = Contact No.
- D = 2 = Normally open
- E = 4 = Normally close

- 01
- 02
- 03
- 04
- 09
- 14
- 17
- 18**
- 19
- 22
- 31
- 41
- 45
- 51
- 56
- 57
- 61
- 70
- 71
- 82
- 84
- 92
- 96

# 18 Raised design

## Illuminated pushbutton rectangular, IP40



Product can differ from the current configuration.

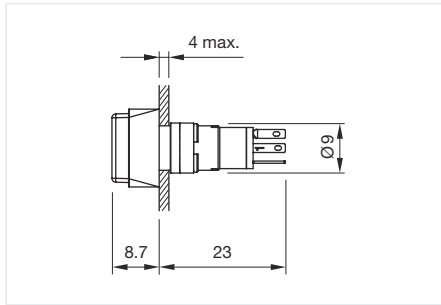

Dimensions [mm]

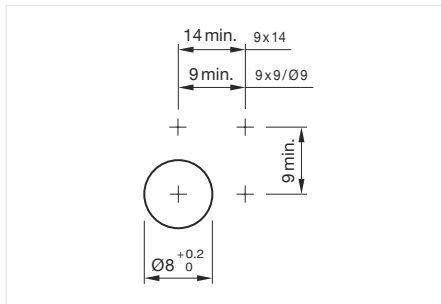

Mounting cut-outs [mm]

### Equipment consisting of (schematic overview)



Lens

Page 398

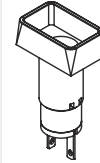

Actuator



Fixing nut

Each Part Number listed below includes all the black components shown in the 3D-drawing.

To obtain a complete unit, please select the red components from the pages shown.



Actuator, Front dimension 14 mm x 9 mm

Switching action	Contacts	Terminal	Part No.	Wiring diagram	Component Layout
Momentary	1 NO	Soldering terminal	18-147.035	133	7
	1 NC	Soldering terminal	18-148.035	131	7
Maintained	1 NO	Soldering terminal	18-247.035	134	7
	1 NC	Soldering terminal	18-248.035	132	7

Contacts: NC = Normally closed, NO = Normally open

### Wiring diagrams

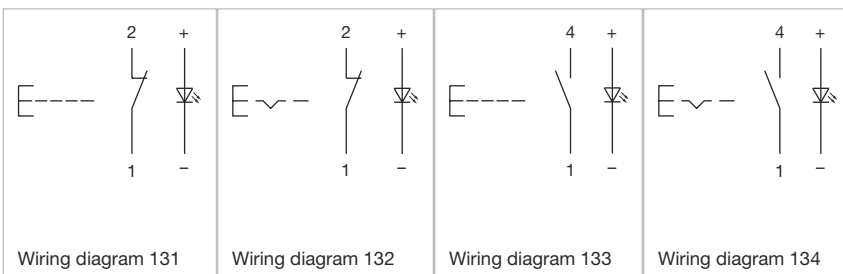



## Component layouts

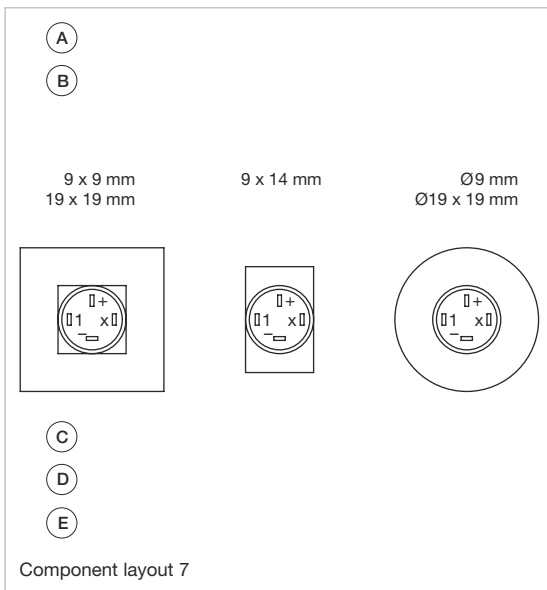

- A = Terminals (rear side)
- B = Illuminated pushbutton
- C = x = Contact No.
- D = 2 = Normally open
- E = 4 = Normally close

- 01
- 02
- 03
- 04
- 09
- 14
- 17
- 18**
- 19
- 22
- 31
- 41
- 45
- 51
- 56
- 57
- 61
- 70
- 71
- 82
- 84
- 92
- 96

# 18 Raised design

## Illuminated pushbutton round, IP40



Product can differ from the current configuration.

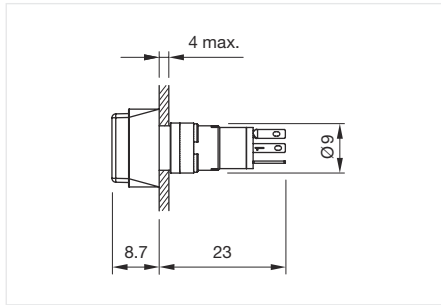

Dimensions [mm]

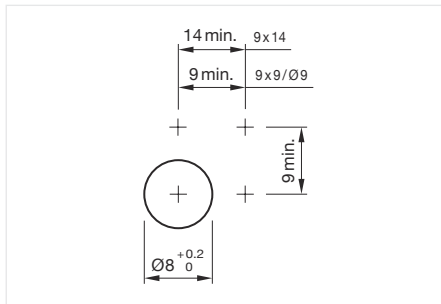

Mounting cut-outs [mm]

### Equipment consisting of (schematic overview)



Lens

Page 398



Actuator



Fixing nut

Each Part Number listed below includes all the black components shown in the 3D-drawing.

To obtain a complete unit, please select the red components from the pages shown.



Actuator, Front dimension Ø 9 mm

Switching action	Contacts	Terminal	Part No.	Wiring diagram	Component Layout
Momentary	1 NO	Soldering terminal	18-137.035	133	7
	1 NC	Soldering terminal	18-138.035	131	7
Maintained	1 NO	Soldering terminal	18-237.035	134	7
	1 NC	Soldering terminal	18-238.035	132	7

Contacts: NC = Normally closed, NO = Normally open

### Wiring diagrams

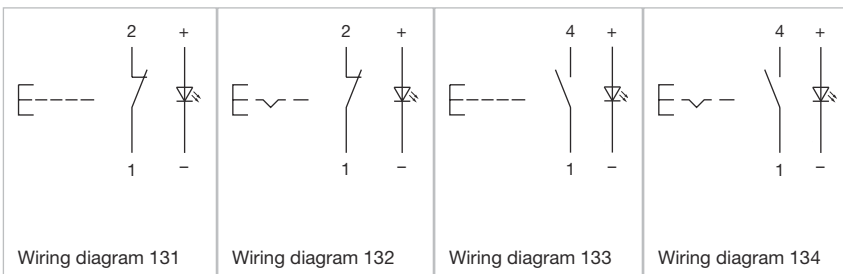

## Component layouts

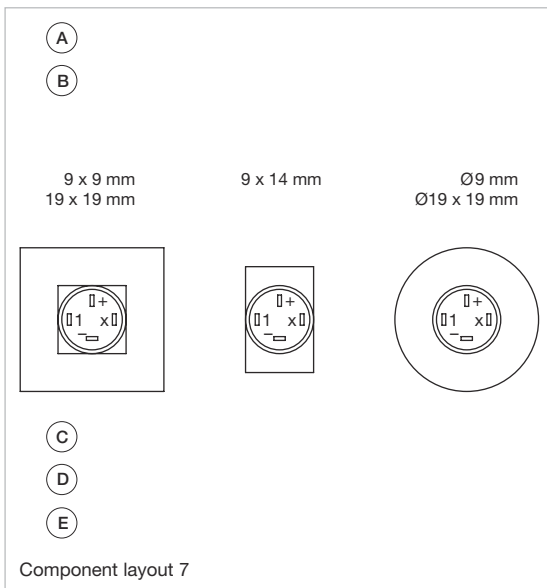

- A = Terminals (rear side)
- B = Illuminated pushbutton
- C = x = Contact No.
- D = 2 = Normally open
- E = 4 = Normally close

- 01
- 02
- 03
- 04
- 09
- 14
- 17
- 18
- 19
- 22
- 31
- 41
- 45
- 51
- 56
- 57
- 61
- 70
- 71
- 82
- 84
- 92
- 96

Follow us.  
We are on YouTube!  
*EAO ermöglicht. Seit 1947.*

[Come take a look at our YouTube profile today!](https://www.youtube.com/user/eaoswitches) Be sure to give us a follow so that you can fully interact with us.

<https://www.youtube.com/user/eaoswitches>

[www.eao.com](http://www.eao.com)

Your Expert Partner for Human Machine Interfaces

# 18 Raised design

## Indicator square, IP40



Product can differ from the current configuration.

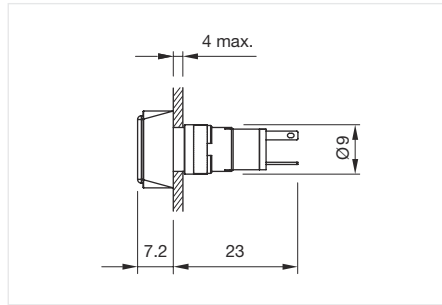

Dimensions [mm]

### General information

- Luminosity and wave length variations caused by LED manufacturing processes may cause slight differences regarding the illumination. The customer has to decide what resistor shall be used to the LED

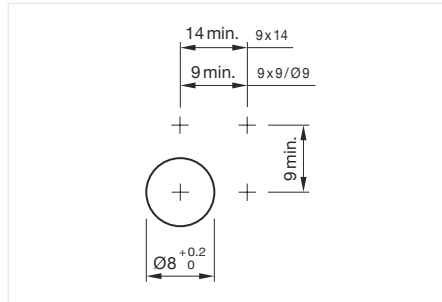

Mounting cut-outs [mm]

### Equipment consisting of (schematic overview)

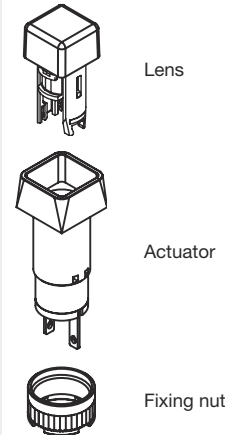

Each Part Number listed below includes all the black components shown in the 3D-drawing.



### Actuator, Front dimension 9 mm x 9 mm

Operating voltage	Illumination colour	Lens colour	Lens shape	Terminal	Part No.	Wiring diagram	Component Layout
Customer specific	Red	Red	flush	Soldering terminal	18-050.0052L	130	6
	White	Yellow	flush	Soldering terminal	18-050.0054L	130	6
	Green	Green	flush	Soldering terminal	18-050.0055L	130	6
12 V DC $\pm 10\%$	Red	Red	flush	Soldering terminal	18-051.0052L	130	6
	Yellow	Yellow	flush	Soldering terminal	18-051.0054L	130	6
24 V DC $\pm 10\%$	Red	Red	flush	Soldering terminal	18-052.0052L	130	6
	Yellow	Yellow	flush	Soldering terminal	18-052.0054L	130	6
	Green	Green	flush	Soldering terminal	18-052.0055L	130	6

## Wiring diagrams

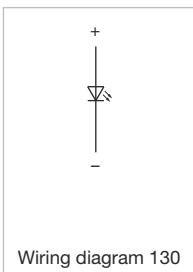

## Component layouts

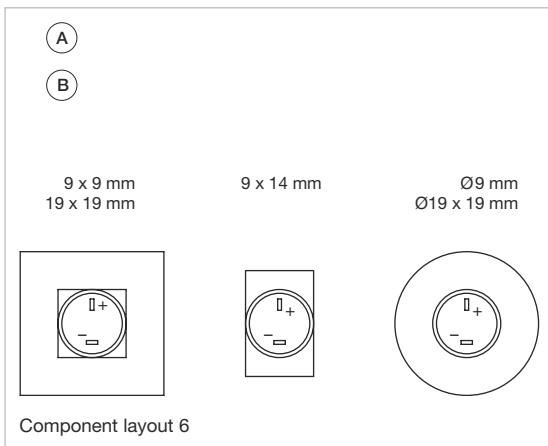

A = Terminals (rear side)  
 B = Indicator

- 01
- 02
- 03
- 04
- 09
- 14
- 17
- 18**
- 19
- 22
- 31
- 41
- 45
- 51
- 56
- 57
- 61
- 70
- 71
- 82
- 84
- 92
- 96

# 18 Raised design

## Indicator rectangular, IP40



Product can differ from the current configuration.

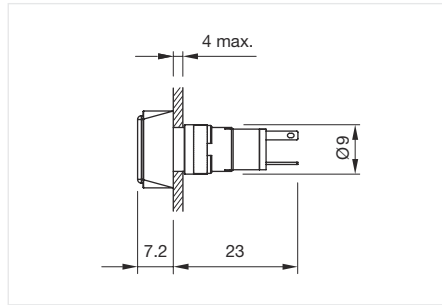

Dimensions [mm]

### General information

- Luminosity and wave length variations caused by LED manufacturing processes may cause slight differences regarding the illumination. The customer has to decide what resistor shall be used to the LED

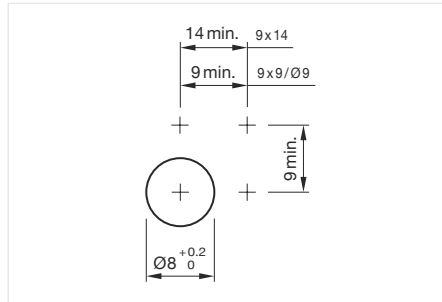

Mounting cut-outs [mm]

### Equipment consisting of (schematic overview)

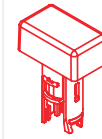

Lens

Page 398



Actuator



Fixing nut

Each Part Number listed below includes all the black components shown in the 3D-drawing.

To obtain a complete unit, please select the red components from the pages shown.



Actuator, Front dimension 14 mm x 9 mm

Operating voltage	Illumination colour	Lens colour	Lens shape	Terminal	Part No.	Wiring diagram	Component Layout
Customer specific	Red	Red	flush	Soldering terminal	18-040.0052L	130	6
	White	Yellow	flush	Soldering terminal	18-040.0054L	130	6
	Green	Green	flush	Soldering terminal	18-040.0055L	130	6
12 V DC $\pm 10\%$		Red	flush	Soldering terminal	18-041.0052L	130	6
		Yellow	flush	Soldering terminal	18-041.0054L	130	6
		Green	flush	Soldering terminal	18-041.0055L	130	6
24 V DC $\pm 10\%$		Red	flush	Soldering terminal	18-042.0052L	130	6
		Yellow	flush	Soldering terminal	18-042.0054L	130	6
		Green	flush	Soldering terminal	18-042.0055L	130	6

## Wiring diagrams

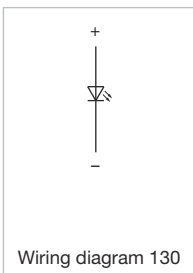

## Component layouts

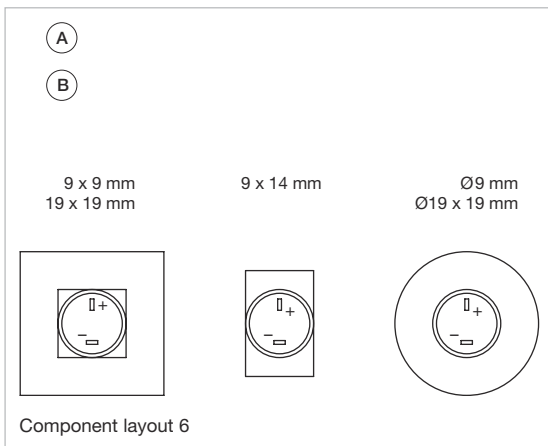

A = Terminals (rear side)  
 B = Indicator

- 01
- 02
- 03
- 04
- 09
- 14
- 17
- 18**
- 19
- 22
- 31
- 41
- 45
- 51
- 56
- 57
- 61
- 70
- 71
- 82
- 84
- 92
- 96

# 18 Raised design

## Indicator round, IP40



Product can differ from the current configuration.

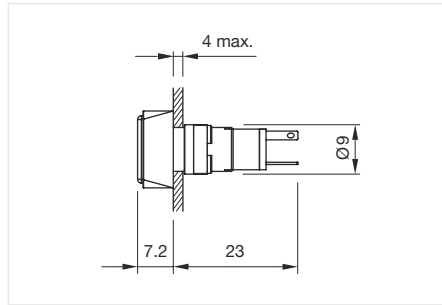

Dimensions [mm]

### General information

- Luminosity and wave length variations caused by LED manufacturing processes may cause slight differences regarding the illumination. The customer has to decide what resistor shall be used to the LED

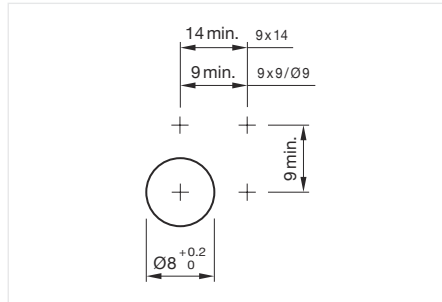

Mounting cut-outs [mm]

### Equipment consisting of (schematic overview)

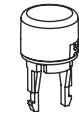

Lens



Actuator



Fixing nut

Each Part Number listed below includes all the black components shown in the 3D-drawing.



### Actuator, Front dimension Ø 9 mm

Operating voltage	Illumination colour	Lens colour	Lens shape	Terminal	Part No.	Wiring diagram	Component Layout
Customer specific	Red	Red	flush	Soldering terminal	18-030.0052L	130	6
	White	Yellow	flush	Soldering terminal	18-030.0054L	130	6
	Green	Green	flush	Soldering terminal	18-030.0055L	130	6
12 V DC ±10 %	Red	Red	flush	Soldering terminal	18-031.0052L	130	6
	Yellow	Yellow	flush	Soldering terminal	18-031.0054L	130	6
	Green	Green	flush	Soldering terminal	18-031.0055L	130	6
24 V DC ±10 %	Red	Red	flush	Soldering terminal	18-032.0052L	130	6
	Yellow	Yellow	flush	Soldering terminal	18-032.0054L	130	6
	Green	Green	flush	Soldering terminal	18-032.0055L	130	6

## Wiring diagrams

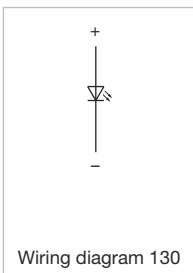



Component layouts

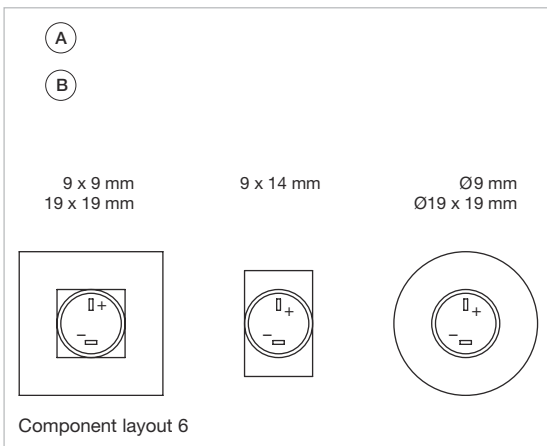

A = Terminals (rear side)  
B = Indicator

01  
02  
03  
04  
09  
14  
17  
**18**  
19  
22  
31  
41  
45  
51  
56  
57  
61  
70  
71  
82  
84  
92  
96



**EAO Downloads.**  
[www.eao.com/downloads](http://www.eao.com/downloads)  
*EAO creates possibilities. Since 1947.*



[On our website you can download technical data, assembly instructions, catalogs, brochures and much more.](http://www.eao.com/downloads)

# 18 Components



## Lens with LED raised design

Lens material	Lens colour	Lens optics	Lens shape	Lens illumination	Dimensions	Part No.	Wiring diagram
Plastic	Red	translucent	flush	illuminative	7.5 mm x 7.5 mm	18-951.2L	139
	Yellow	translucent	flush	illuminative	7.5 mm x 7.5 mm	18-951.4L	139
	Green	translucent	flush	illuminative	7.5 mm x 7.5 mm	18-951.5L	139
	Red	translucent	flush	illuminative	7.5 mm x 12.5 mm	18-941.2L	139
	Yellow	translucent	flush	illuminative	7,5 mm x 12.5 mm	18-941.4L	139
	Green	translucent	flush	illuminative	7,5 mm x 12.5 mm	18-941.5L	139
	Red	translucent	flush	illuminative	Ø 7.5 mm	18-931.2L	139
	Yellow	translucent	flush	illuminative	Ø 7.5 mm	18-931.4L	139
	Green	translucent	flush	illuminative	Ø 7.5 mm	18-931.5L	139

### Additional information

- Luminosity and wave length variations caused by LED manufacturing processes may cause slight differences regarding the illumination. The customer has to decide what resistor shall be used to the LED
- Red LED Vf = 2.0 V DC, yellow lens with white LED Vf = 3.2 V, green LED Vf = 3.2 V

## Wiring diagrams

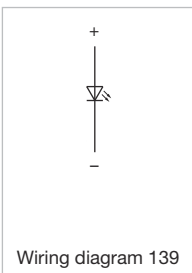

## Lens with LED flush design

Lens material	Lens colour	Lens optics	Lens shape	Lens illumination	Dimensions	Part No.	Wiring diagram
Plastic	Red	translucent	flush	illuminative	13.8 mm x 13.8 mm	18-981.2L	139
	Yellow	translucent	flush	illuminative	13.8 mm x 13.8 mm	18-981.4L	139
	Green	translucent	flush	illuminative	13.8 mm x 13.8 mm	18-981.5L	139
	Red	translucent	flush	illuminative	Ø 13.8 mm	18-961.2L	139
	Yellow	translucent	flush	illuminative	Ø 13.8 mm	18-961.4L	139
	Green	translucent	flush	illuminative	Ø 13.8 mm	18-961.5L	139

### Additional information

- Luminosity and wave length variations caused by LED manufacturing processes may cause slight differences regarding the illumination. The customer has to decide what resistor shall be used to the LED
- Red LED Vf = 2.0 V DC, yellow lens with white LED Vf = 3.2 V, green LED Vf = 3.2 V

## Wiring diagrams

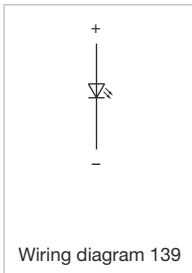

### Lens without LED raised design

Lens material	Lens colour	Lens optics	Lens shape	Lens illumination	Dimensions	Part No.
Plastic	Black	opaque	flush	non illuminative	7.5 mm x 7.5 mm	18-952.0
	Red	translucent	flush	illuminative	7.5 mm x 7.5 mm	18-952.2
	Yellow	translucent	flush	illuminative	7.5 mm x 7.5 mm	18-952.4
	Green	translucent	flush	illuminative	7.5 mm x 7.5 mm	18-952.5
	Grey	opaque	flush	non illuminative	7.5 mm x 7.5 mm	18-952.8
	White	translucent	flush	illuminative	7.5 mm x 7.5 mm	18-952.9
	Black	opaque	flush	non illuminative	7.5 mm x 12.5 mm	18-942.0
	Red	translucent	flush	illuminative	7.5 mm x 12.5 mm	18-942.2
	Yellow	translucent	flush	illuminative	7.5 mm x 12.5 mm	18-942.4
	Green	translucent	flush	illuminative	7.5 mm x 12.5 mm	18-942.5
	Grey	opaque	flush	non illuminative	7.5 mm x 12.5 mm	18-942.8
	White	translucent	flush	illuminative	7.5 mm x 12.5 mm	18-942.9
	Black	opaque	flush	non illuminative	Ø 7.5 mm	18-932.0
	Red	translucent	flush	illuminative	Ø 7.5 mm	18-932.2
	Yellow	translucent	flush	illuminative	Ø 7.5 mm	18-932.4
	Green	translucent	flush	illuminative	Ø 7.5 mm	18-932.5
	Grey	opaque	flush	non illuminative	Ø 7.5 mm	18-932.8
	White	translucent	flush	illuminative	Ø 7.5 mm	18-932.9



### Lens without LED flush design

Lens material	Lens colour	Lens optics	Lens shape	Lens illumination	Dimensions	Part No.
Plastic	Black	opaque	flush	non illuminative	13.8 mm x 13.8 mm	18-982.0
	Red	translucent	flush	illuminative	13.8 mm x 13.8 mm	18-982.2
	Yellow	translucent	flush	illuminative	13.8 mm x 13.8 mm	18-982.4
	Green	translucent	flush	illuminative	13.8 mm x 13.8 mm	18-982.5
	Grey	opaque	flush	non illuminative	13.8 mm x 13.8 mm	18-982.8
	White	translucent	flush	illuminative	13.8 mm x 13.8 mm	18-982.9
	Black	opaque	flush	non illuminative	Ø 13.8 mm	18-962.0
	Red	translucent	flush	illuminative	Ø 13.8 mm	18-962.2
	Yellow	translucent	flush	illuminative	Ø 13.8 mm	18-962.4
	Green	translucent	flush	illuminative	Ø 13.8 mm	18-962.5
	Grey	opaque	flush	non illuminative	Ø 13.8 mm	18-962.8
	White	translucent	flush	illuminative	Ø 13.8 mm	18-962.9

# 18 Components



Front bezel set flush design

Product attributes	Front bezel material	Front bezel colour	Mounting cut-out	Dimensions	Part No.
For square lens	Plastic	Black	15.8 mm x 15.8 mm	19 mm x 19 mm	18-920.1
For round lens	Plastic	Black	15.8 mm x 15.8 mm	19 mm x 19 mm	18-920.2
	Plastic	Black	Ø 16 mm	Ø 19 mm	18-920.3

- 01
- 02
- 03
- 04
- 09
- 14
- 17
- 18**
- 19
- 22
- 31
- 41
- 45
- 51
- 56
- 57
- 61
- 70
- 71
- 82
- 84
- 92
- 96

## Rear side



PCB plug-in base

Terminal	Pins	Part No.	Component Layout
PCB terminal	Axial	18-945	14
	90° angled	18-946	15

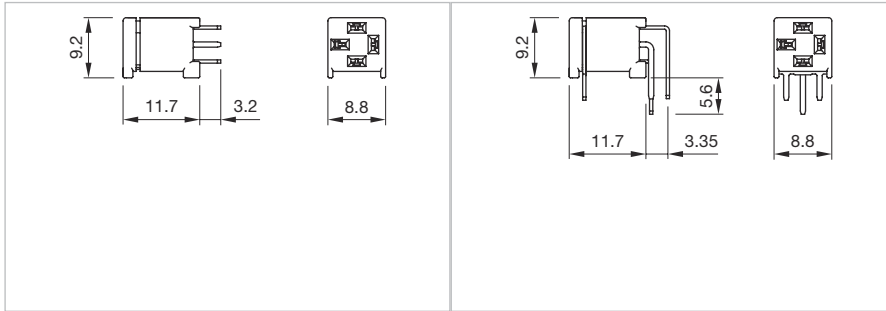

Dimensions [mm]  
for Part No. 18-945

Dimensions [mm]  
for Part No. 18-946

- 01
- 02
- 03
- 04
- 09
- 14
- 17
- 18**
- 19
- 22
- 31
- 41
- 45
- 51
- 56
- 57
- 61
- 70
- 71
- 82
- 84
- 92
- 96

# 18 Accessories

## Component layouts

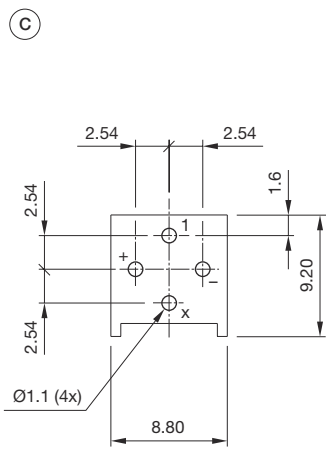
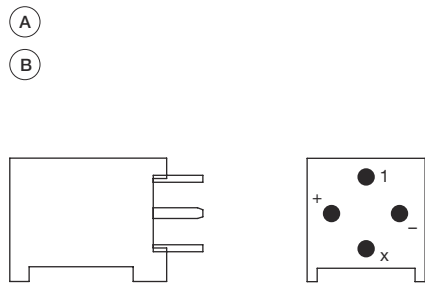

Component layout 14

Dimensions [mm]

A = Axial socket

B = Occupancy plan (component side)

C = Drilling plan (component side)

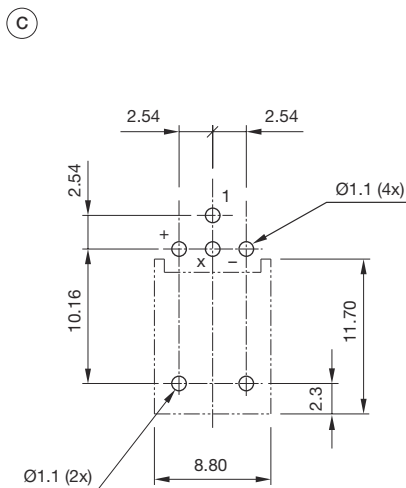
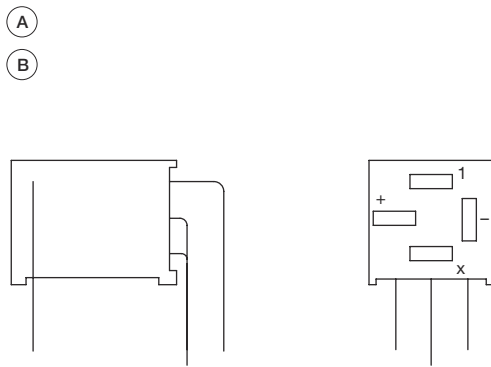

Component layout 15

Dimensions [mm]

A = Socket 90° angled

B = Occupancy plan (component side)

C = Drilling plan (component side)

D = non-metallic

E = x = Contact No.

F = 2 = Normaly open

G = 4 = Normaly close

## Mounting



**Fixing nut**

Dimensions	Material	Thread	Part No.
Ø 9 mm	metal	M8 x 13 mm	19-991



**Lens remover**

Material	Part No.
metal / plastic	18-910



**Mounting tool**

Product attributes	Material	Part No.
For fixing nut long Part No. 19-991	metal	19-905

- 01
- 02
- 03
- 04
- 09
- 14
- 17
- 18**
- 19
- 22
- 31
- 41
- 45
- 51
- 56
- 57
- 61
- 70
- 71
- 82
- 84
- 92
- 96

# 18 Technical data

## Actuator with snap-action switching element

### Switching system

The snap-action switching system was designed for switching low powers in electronic circuits.  
Single-break snap-action contact.

Operating data LED:	red	2.0 VDC @ 20mA
	yellow	2.1 VDC @ 20mA
	green	3.2 VDC @ 20mA
	white	3.2 VDC @ 20mA

### Material

Lens  
Plastic

#### Electrical life

≥ 500 000 cycles of operation at 30 VDC, 100 mA, according to IEC 61058-1

#### Switching voltage and switching current

100 mA at 42 VAC/VDC

### Material of contact

Gold contact on nickel plating

#### Electric strength

500 VAC, 50 Hz, 1 minute between all terminals and earth, as per IEC 60512-2-11

### Actuator housing

Plastic, colour black

### Ambient conditions

#### Storage temperature

−40 °C ... +80 °C

#### Operating temperature

−25 °C ... +65 °C

#### Protection degree

IP40 front side, as per IEC 60529

#### Shock resistance

(Single impacts, semi-sinusoidal)  
50 g for 11 ms, as per DIN EN 60068-2-27

#### Vibration resistance

(sinusoidal)  
10 g at 10–2000 Hz, amplitude 0.75 mm, as per IEC 60512-4-4

### Approvals

#### Conformities

2014/35/EC (LVD) for version 230 VAC  
2011/65/EC (RoHS)

### Mechanical characteristics

#### Terminals

The terminals can be used as soldering terminals.

Max. wire diameter	2 x 0.5 mm <sup>2</sup>
Max. wire cross-section of stranded cable	1 x 0.75 mm <sup>2</sup>
Wire cross-section of terminal	1.6 x 0.4 mm <sup>2</sup>

#### Tightening torque

For fixing nut max. 0.2 Nm

#### Actuating force

1.4 N

#### Actuating travel

Approx. 2.2 mm ± 0.2 mm

#### Mechanical lifetime

Momentary action 2 million cycles of operation  
Maintained action 1 million cycles of operation

### Electrical characteristics

#### Illumination

Operating voltage LED: 12 VDC ± 10 %  
24 VDC ± 10 %  
customer-specific \*)

\*) The series resistance for LEDs need to be determined and integrated by customers.

EAO reserves the right to alter specifications without further notice.



## Suppressor circuits

When switching inductive loads such as relays, DC motors, and DC solenoids, it is always important to absorb surges (e.g. with a diode) to protect the contacts. When these inductive loads are switched off, a counter emf can severely damage switch contacts and greatly shorten lifetime.

Fig. 1 shows an inductive load with a free-wheeling diode connected in parallel. This free-wheeling diode provides a path for the inductor current to flow when the current is interrupted by the switch. Without this free-wheeling diode, the voltage across the coil will be limited only by dielectric breakdown voltages of the circuit or parasitic elements of the coil. This voltage can be kilo-

volts in amplitude even when nominal circuit voltages are low (e.g. 12VDC) see Fig. 2.

The free-wheeling diode should be chosen so that the reverse breakdown voltage is greater than the voltage driving the inductive load. The DC blocking voltage ( $V_R$ ) of the free-wheeling diode can be found in the datasheet of a diode. The forward current should be equal or greater than the maximum current flowing through the load.

**To get an efficient protection, the free-wheeling diode must be connected as close as possible to the inductive load!**

Switching with inductive load  
Fig. 1

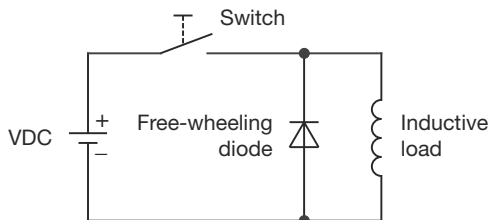

Counter EMF  
over load without free-wheeling diode  
Fig. 2

