

PRODUCT NO.

SEE TABLE

1 | 2 | 3 | 4 | 5 | 6

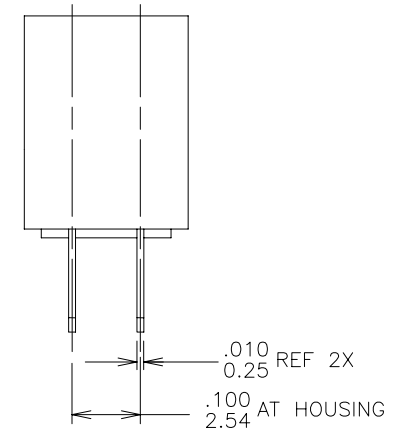
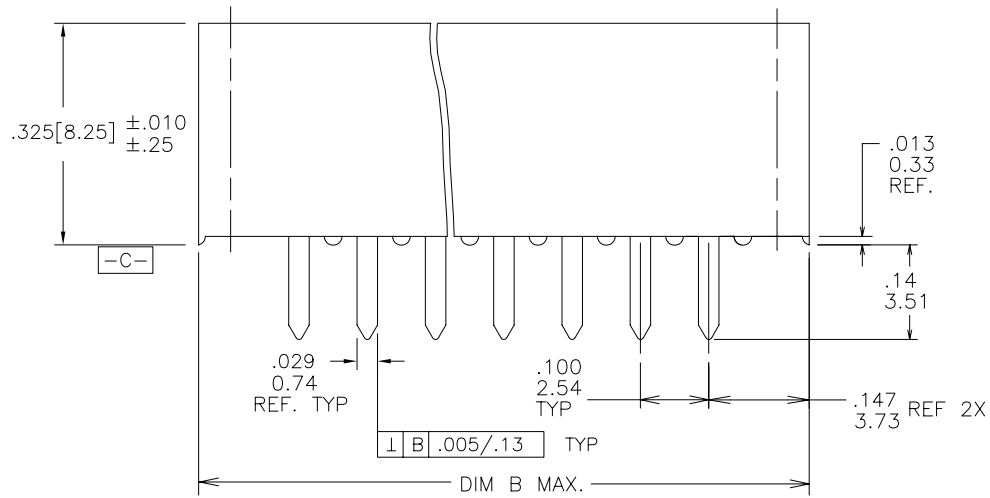
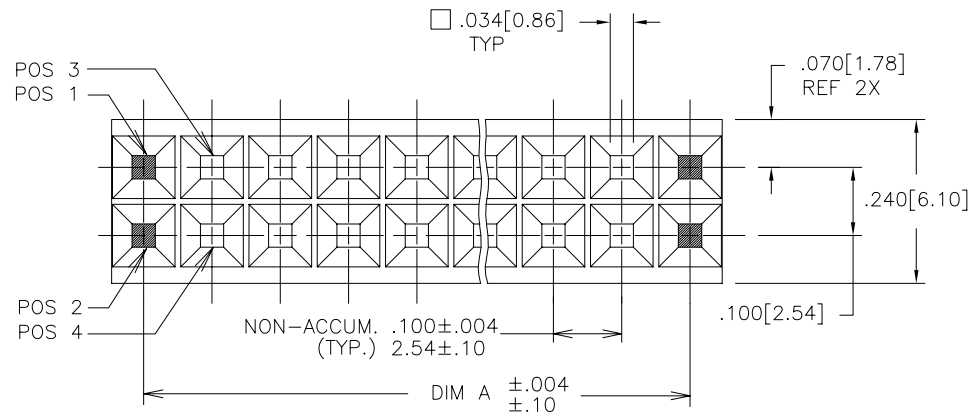

Copyright FCI

mat'l. code		surface ISO 1302 ✓		tolerance ISO 406 ISO 1101		projection ⊕		product family CARD CONN	
ltr		ecn no		date		tolerances unless otherwise specified		title	
D	V02101	JGS	1/8/91	angles	linear	.XX±.01/.X±.3	INCH/MM	VERT. CARD CONN. .100/2.54 DBL	
E	V70493	SAR	4/22/97			.XXX±.0.005/.XX±.13		ROW SELECT LOAD 30μ"/.76μ Au	
F	V70792	JM	11/15/97	0°±2'		.XXXX±.0020/.XXX±.051	scale 4:1	dwg no sheet 1 of 4 size	
G	M05-0216	ERE	10/11/05	dr	J. SHREINER	1/8/91		68768 A3	
H	M06-0210	MHT	6/03/06	engr	M.HAHN	1/8/91		type Product Customer Drawing	
J	M07-0143	ERE	03/03/07	chr	M.HAHN	1/8/91			
				appd	M.HAHN	1/8/91			
sheet index	revision sheet	J	J	J	J	J			
		1	2	3	4				

form: A3

1 | 2 | 3 | 4 | 5 | 6

PRODUCT NO.
SEE TABLE

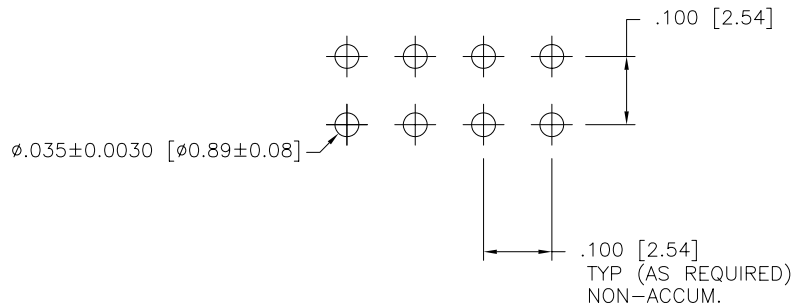

FIG. D

NOTES:

- ①. HOUSING MATERIAL: FILLED POLYESTER, FLAME RETARDANT PER UL 94V-0. COLOR: BLACK
- ②. TERMINAL MATERIAL:
 BODY: BRASS
 SPRING: BeCu HEAT TREATED
 BODY PLATING: 30u"/0.76u Au over
 50u"/1.27u Ni IN CONTACT AREA
 100u"/2.54u Sn (NOTE 8) over
 50u"/1.27u Ni ON SOLDERTAIL.
 SPRING PLATING: GOLD FLASH
3. MARKING: FCI PART NUMBER AND DATE CODE LEGIBLE ON TUBE LABEL.
4. APPLICATION INFORMATION:
 A. RECOMMENDED MOUNTING HOLE PATTERN IS SHOWN IN "FIG. D"
 B. ALL MATING PINS TO BE .025/0.64 SQUARE ON TRUE CENTER OF GIVEN TERMINAL SPACINGS WITHIN .015/0.38 DIA.
 C. SUGGESTED MATING PIN LENGTH .210±.020 / 5.33±.51.
- ⑤. ADD "LF" SUFFIX AT THE END OF PART NUMBER FOR LEAD FREE OPTION.
- ⑥. THESE PRODUCTS MEET EUROPEAN UNION DIRECTIVES AND OTHER COUNTRY REGULATIONS AS DESCRIBED IN GS-22-008.
7. THIS PART WILL WITHSTAND EXPOSURE TO 260°C PEAK TEMPERATURE FOR 20 SECONDS IN WAVE SOLDER, INFRA-RED OR VAPOR PHASE SOLDER PROCESS.
- ⑧. "THIS PRODUCT HAS 100% TIN PLATING IN THE INTERFACE AND HAS NOT BEEN TESTED FOR WHISKER GROWTH IN ALL INTERCONNECT ENVIRONMENTS."



Copyright FCI

mat'l. code		surface ISO 1302 ✓		tolerance ISO 406 ISO 1101		projection ⊕		product family CARD CONN	
ltr		ecn no		date		tolerances unless otherwise specified		title	
J						.XX±.01/.X±.3		VERT. CARD CONN. .100/2.54 DBL	
				angles		linear		INCH/MM	
				0°±2'		.XXX±.0.005/.XX±.13		ROW SELECT LOAD 30μ"/.76μ Au	
						.XXXX±.0020/.XXX±.051		scale 4:1	
				dr		J. SHREINER 1/8/91		dwg no	
				enr		M.HAHN 1/8/91		sheet 2 of 4 size	
				chr		M.HAHN 1/8/91		68768 A3	
				appd		M.HAHN 1/8/91		type Product Customer Drawing	
sheet index		revision sheet							

PRODUCT NO.	NO. OF POS.	DIM A	DIM B	UNLOADED POSITIONS	LEAD FREE OPTION
68768-004	2 X 4	.300[7.62]	.400[10.16]	1,2,7,8	NOTE 5,6
68768-005	2 X 5	.400[10.16]	.500[12.70]	1,2,9,10	
68768-006	2 X 6	.500[12.70]	.600[15.24]	1,2,11,12	
68768-007	2 X 7	.600[15.24]	.700[17.78]	1,2,13,14	
68768-008	2 X 8	.700[17.78]	.800[20.32]	1,2,15,16	
68768-009	2 X 9	.800[20.32]	.900[22.86]	1,2,17,18	
68768-010	2 X 10	.900[22.86]	1.000[25.40]	1,2,19,20	
68768-011	2 X 11	1.000[25.40]	1.100[27.94]	1,2,21,22	
68768-012	2 X 12	1.100[27.94]	1.200[30.48]	1,2,23,24	
68768-013	2 X 13	1.200[30.48]	1.300[33.02]	1,2,25,26	
68768-014	2 X 14	1.300[33.02]	1.400[35.56]	1,2,27,28	
68768-015	2 X 15	1.400[35.56]	1.500[38.10]	1,2,29,30	
68768-016	2 X 16	1.500[38.10]	1.600[40.64]	1,2,31,32	
68768-017	2 X 17	1.600[40.64]	1.700[43.18]	1,2,33,34	
68768-018	2 X 18	1.700[43.18]	1.800[45.72]	1,2,35,36	
68768-019	2 X 19	1.800[45.72]	1.900[48.26]	1,2,37,38	
68768-020	2 X 20	1.900[48.26]	2.000[50.80]	1,2,39,40	
68768-021	2 X 21	2.000[50.80]	2.100[53.34]	1,2,41,42	
68768-022	2 X 22	2.100[53.34]	2.200[55.88]	1,2,43,44	
68768-023	2 X 23	2.200[55.88]	2.300[58.42]	1,2,45,46	
68768-024	2 X 24	2.300[58.42]	2.400[60.96]	1,2,47,48	
68768-025	2 X 25	2.400[60.96]	2.500[63.50]	1,2,49,50	
68768-026	2 X 26	2.500[63.50]	2.600[66.04]	1,2,51,52	
68768-027	2 X 27	2.600[66.04]	2.700[68.58]	1,2,53,54	
68768-028	2 X 28	2.700[68.58]	2.800[71.12]	1,2,55,56	
68768-029	2 X 29	2.800[71.12]	2.900[73.66]	1,2,57,58	
68768-030	2 X 30	2.900[73.66]	3.000[76.20]	1,2,59,60	
68768-031	2 X 31	3.000[76.20]	3.100[78.74]	1,2,61,62	
68768-032	2 X 32	3.100[78.74]	3.200[81.28]	1,2,63,64	
68768-033	2 X 33	3.200[81.28]	3.300[83.82]	1,2,65,66	
68768-034	2 X 34	3.300[83.82]	3.400[86.36]	1,2,67,68	
68768-035	2 X 35	3.400[86.36]	3.500[88.90]	1,2,69,70	
68768-036	2 X 36	3.500[88.90]	3.600[91.44]	1,2,71,72	NOTE 5,6



Copyright FCI

mat'l. code		surface ISO 1302 <input checked="" type="checkbox"/>		tolerance ISO 406 ISO 1101		projection 		product family CARD CONN	
ltr	ecn	no	dr	date		tolerances unless otherwise specified		title	
J						.XX±.01/.X±.3		VERT. CARD CONN. .100/2.54 DBL	
						linear		INCH/MM	
				0'±2'		.XXX±.0.005/.XX±.13		ROW SELECT LOAD 30μ"/.76μ Au	
						.XXXX±.0020/.XXX±.051		scale 4:1	
				dr		J. SHREINER 1/8/91		sheet 3 of 4 size	
				enr		M.HAHN 1/8/91		68768 A3	
				chr		M.HAHN 1/8/91		type Product Customer Drawing	
				appd		M.HAHN 1/8/91			
sheet index	revision sheet								

PRODUCT NO.	NO. OF POS.	DIM A	DIM B	UNLOADED POSITIONS	LEAD FREE OPTION
68768-037	-2- X-37	----	DISCONTINUED	----	1,2,73,74
68768-038	-2- X-38	----	DISCONTINUED	----	1,2,75,76
68768-039	-2- X-39	----	DISCONTINUED	----	1,2,77,78
68768-040	-2- X-40	----	DISCONTINUED	----	1,2,79,80
68768-041	-2- X-41	----	DISCONTINUED	----	1,2,81,82
68768-042	-2- X-42	----	DISCONTINUED	----	1,2,83,84
68768-043	-2- X-43	----	DISCONTINUED	----	1,2,85,86
68768-044	-2- X-44	----	DISCONTINUED	----	1,2,87,88
68768-045	-2- X-45	----	DISCONTINUED	----	1,2,89,90
68768-046	-2- X-46	----	DISCONTINUED	----	1,2,91,92
68768-047	-2- X-47	----	DISCONTINUED	----	1,2,93,94
68768-048	-2- X-48	----	DISCONTINUED	----	1,2,95,96
68768-049	-2- X-49	----	DISCONTINUED	----	1,2,97,98
68768-050	-2- X-50	----	DISCONTINUED	----	1,2,99,100
68768-101	2 X 22	2.100/53.34	2.200/55.88	9	NOTE 5,6



Copyright FCI

mat'l. code		surface ISO 1302 <input checked="" type="checkbox"/>		tolerance ISO 406 ISO 1101		projection 		product family CARD CONN	
ltr	ecn	no	dr	date	tolerances unless otherwise specified		INCH/MM scale 4:1	title	
J					angles	linear		VERT. CARD CONN. .100/2.54 DBL ROW SELECT LOAD 30μ"/.76μ Au	
					0°±2'			dwg no sheet 4 of 4 size	
					dr	J. SHREINER	1/8/91	68768 A3	
					enr	M.HAHN	1/8/91	type Product Customer Drawing	
					chr	M.HAHN	1/8/91		
					appd	M.HAHN	1/8/91		
sheet index	revision sheet								

form: A3 1 2 3 4 5 6