

67 SERIES BULKHEAD COMPU-SHIELD TERMINATION INSTRUCTIONS

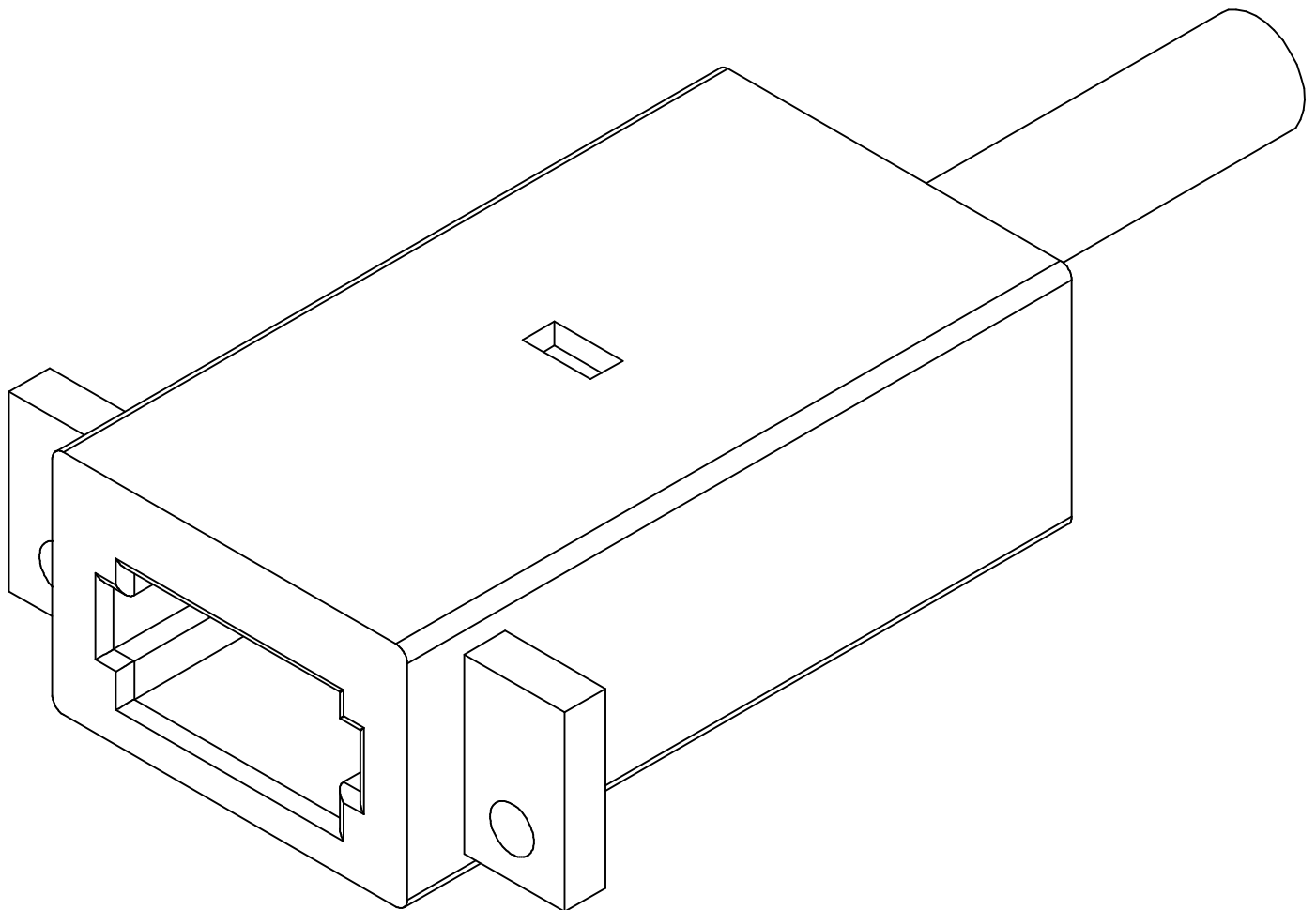

Stewart Connector

BEL STEWART CONNECTOR

11118 Susquehanna Trail South
Glen Rock, PA 17327-9199
(717) 235-7512 Fax: (717) 235-7954
WWW.STEWARTCONNECTOR.COM

1. CUT CABLE TO DESIRED LENGTH.
2. SLIDE TERMINATION END OF CABLE THROUGH THE HOLE IN THE LOAD BAR AS SHOWN.

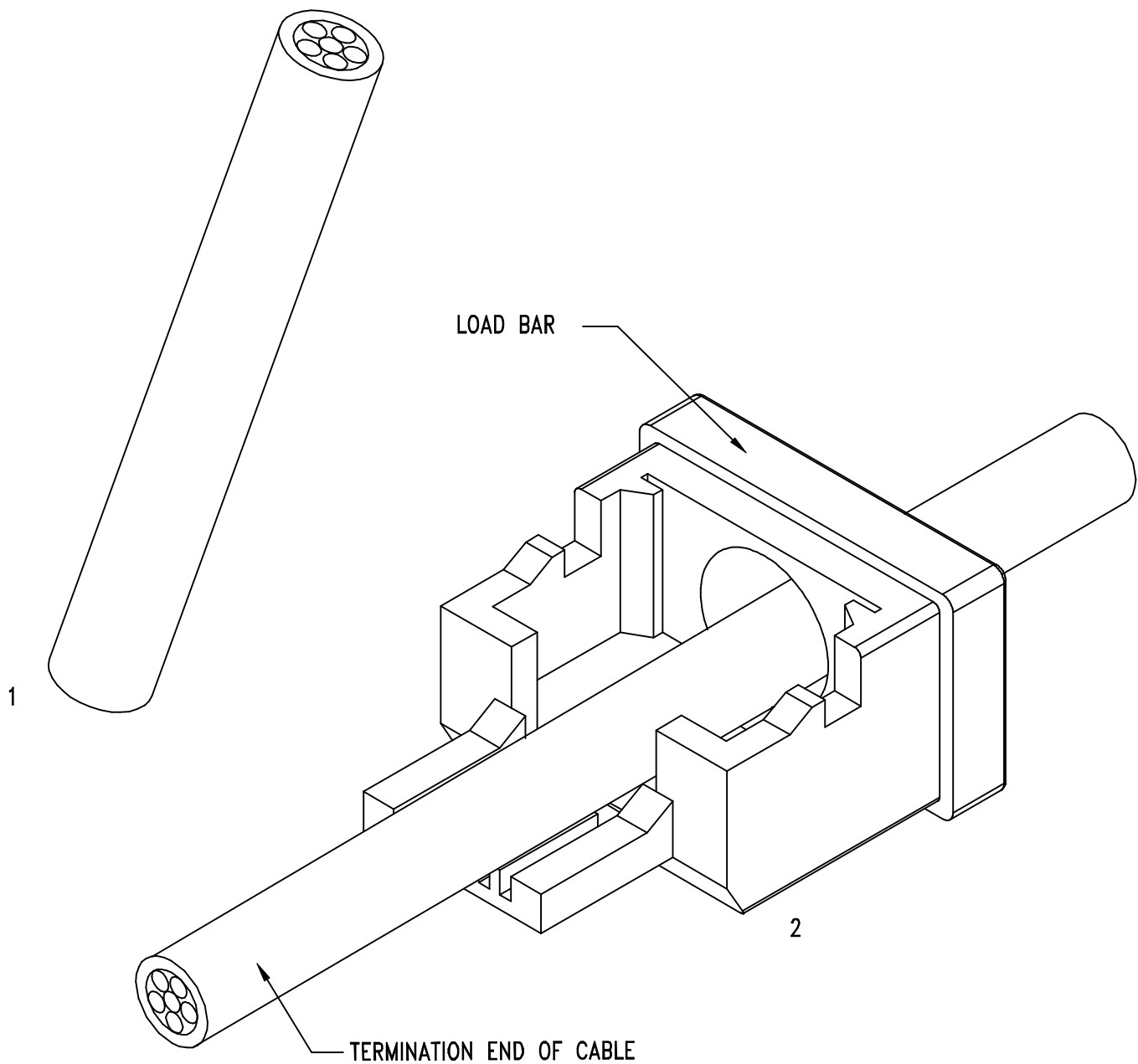

Stewart Connector

BEL STEWART CONNECTOR

11118 Susquehanna Trail South
Glen Rock, PA 17327-9199
(717) 235-7512 Fax: (717) 235-7954
WWW.STEWARTCONNECTOR.COM

3. TRIM BACK CABLE JACKET TO EXPOSE APPROXIMATELY 2.0–2.5 INCHES [50.8–63.5 mm] OF SHIELDED CONDUCTORS.
4. PEEL BACK SHIELDING OVER CABLE JACKET TO EXPOSE CONDUCTORS.

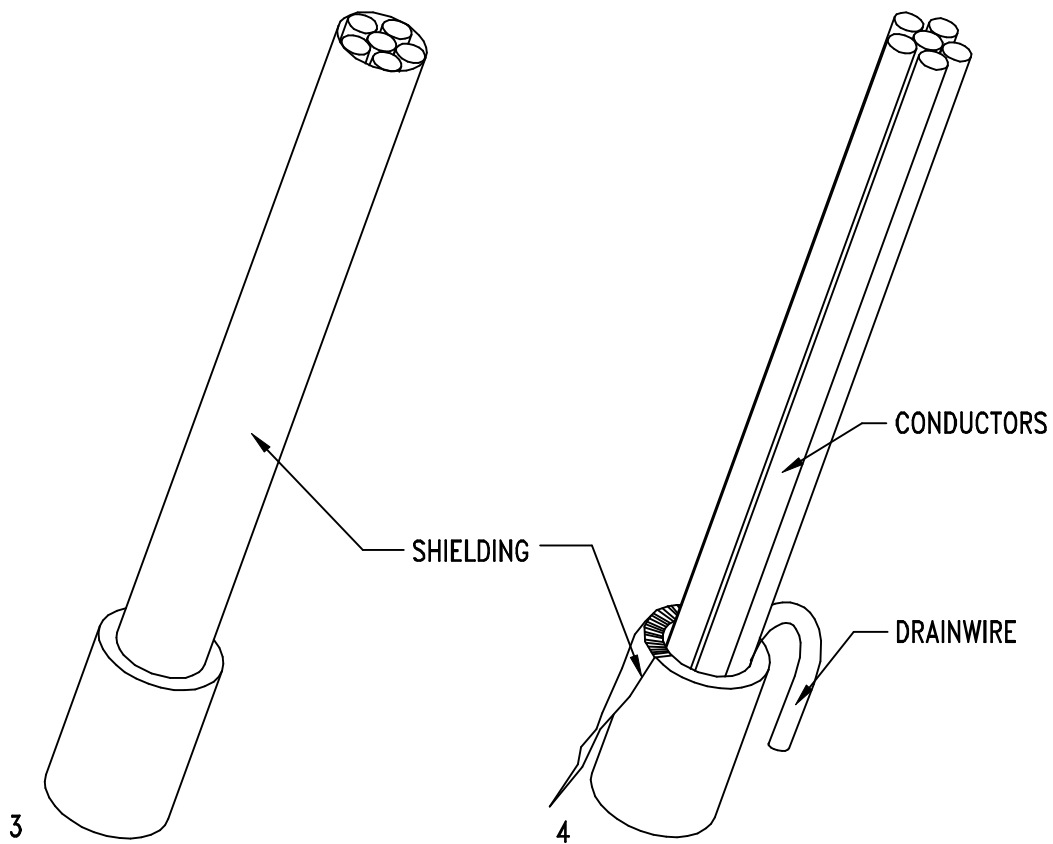

Stewart Connector

BEL STEWART CONNECTOR

11118 Susquehanna Trail South
Glen Rock, PA 17327-9199
(717) 235-7512 Fax: (717) 235-7954
WWW.STEWARTCONNECTOR.COM

5. SLIDE FERRULE OVER JACKET AND SHIELDING, BEING SURE TO MAKE CONTACT WITH SHIELDING.

NOTE: THE FERRULE'S ROUNDED EDGE GOES TOWARD THE END OF THE CABLE JACKET LEAVING APPROXIMATELY .03 OF AN INCH OF INSULATION EXPOSED.

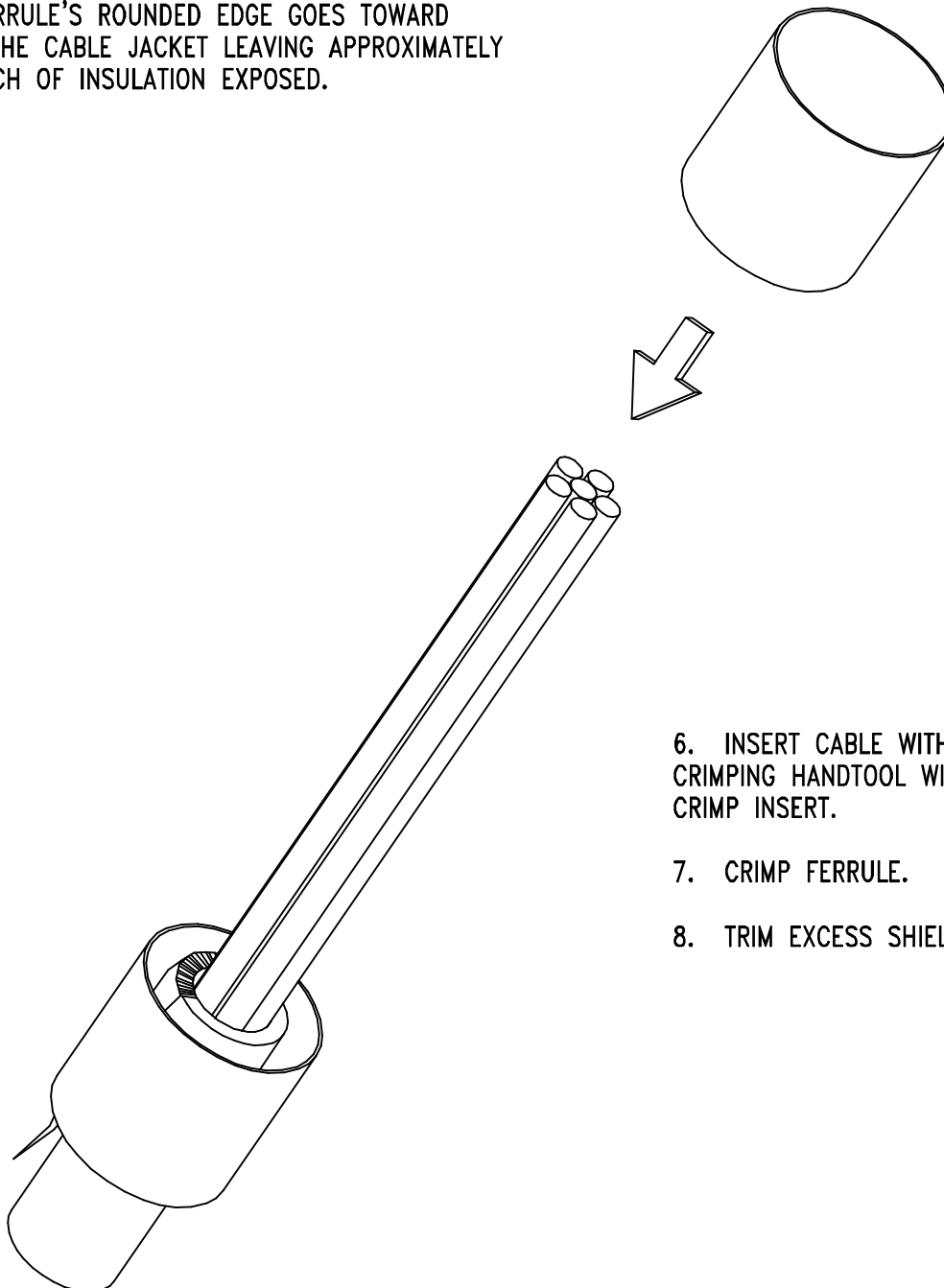

6. INSERT CABLE WITH FERRULE INTO CRIMPING HANDTOOL WITH APPROPRIATE CRIMP INSERT.

7. CRIMP FERRULE.

8. TRIM EXCESS SHIELDING AND DRAIN WIRE.

Stewart Connector

BEL STEWART CONNECTOR

11118 Susquehanna Trail South
Glen Rock, PA 17327-9199
(717) 235-7512 Fax: (717) 235-7954
WWW.STEWARTCONNECTOR.COM

FERRULE CRIMPING TOOL

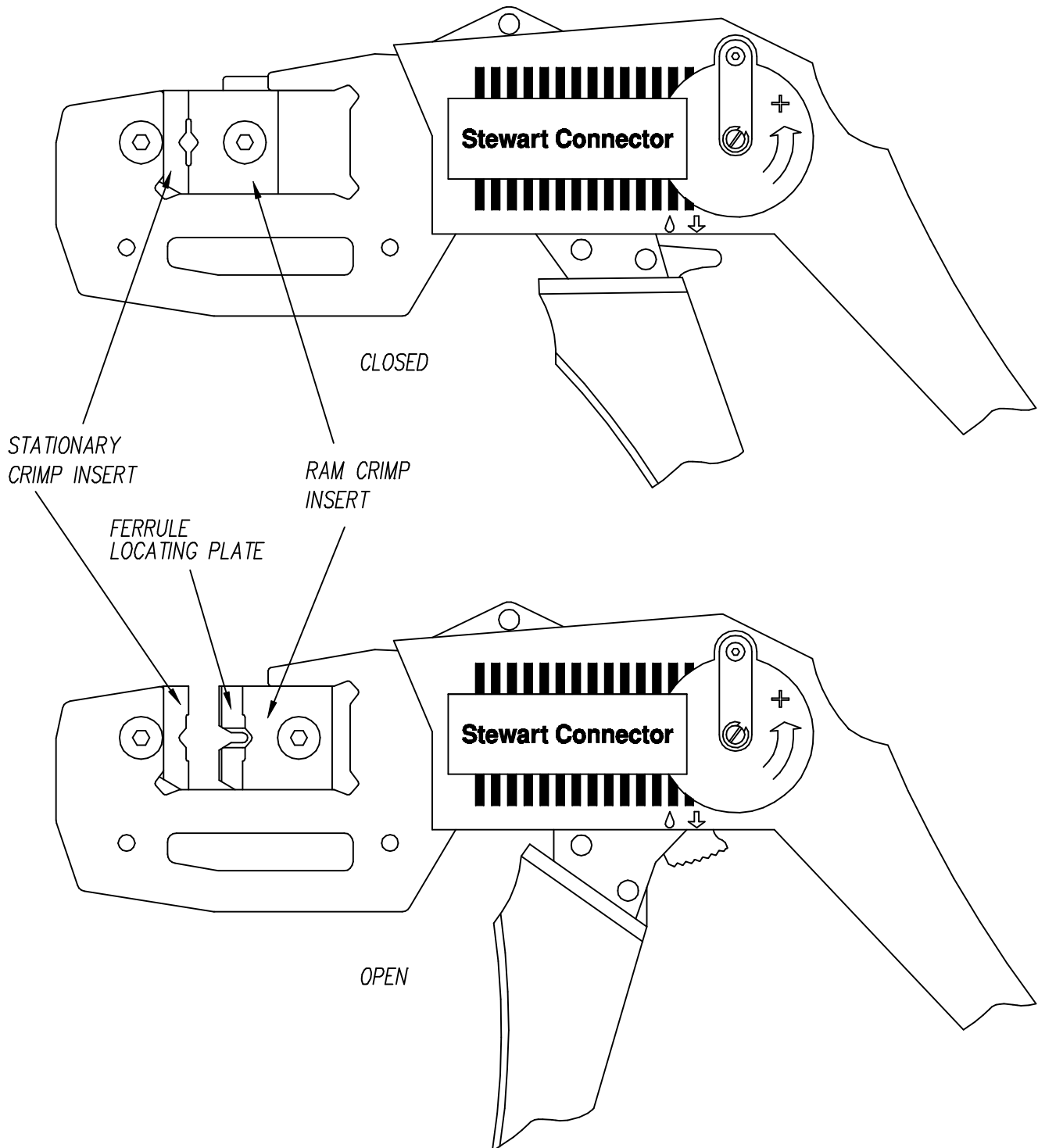

Stewart Connector

BEL STEWART CONNECTOR

11118 Susquehanna Trail South
Glen Rock, PA 17327-9199
(717) 235-7512 Fax: (717) 235-7954
WWW.STEWARTCONNECTOR.COM

9. ARRANGE CONDUCTORS INTO APPROPRIATE TERMINATION SEQUENCE,
PLACE AND LOCATE FERRULE ASSEMBLY INTO LOAD BAR. BE SURE THE
FERRULE MAKES CONTACT WITH THE METAL SHIELD IN THE LOAD BAR.

FERRULE CRIMP HEIGHT = $.19 \pm .01$ (DEPENDENT UPON CABLE TYPE AND SIZE.)

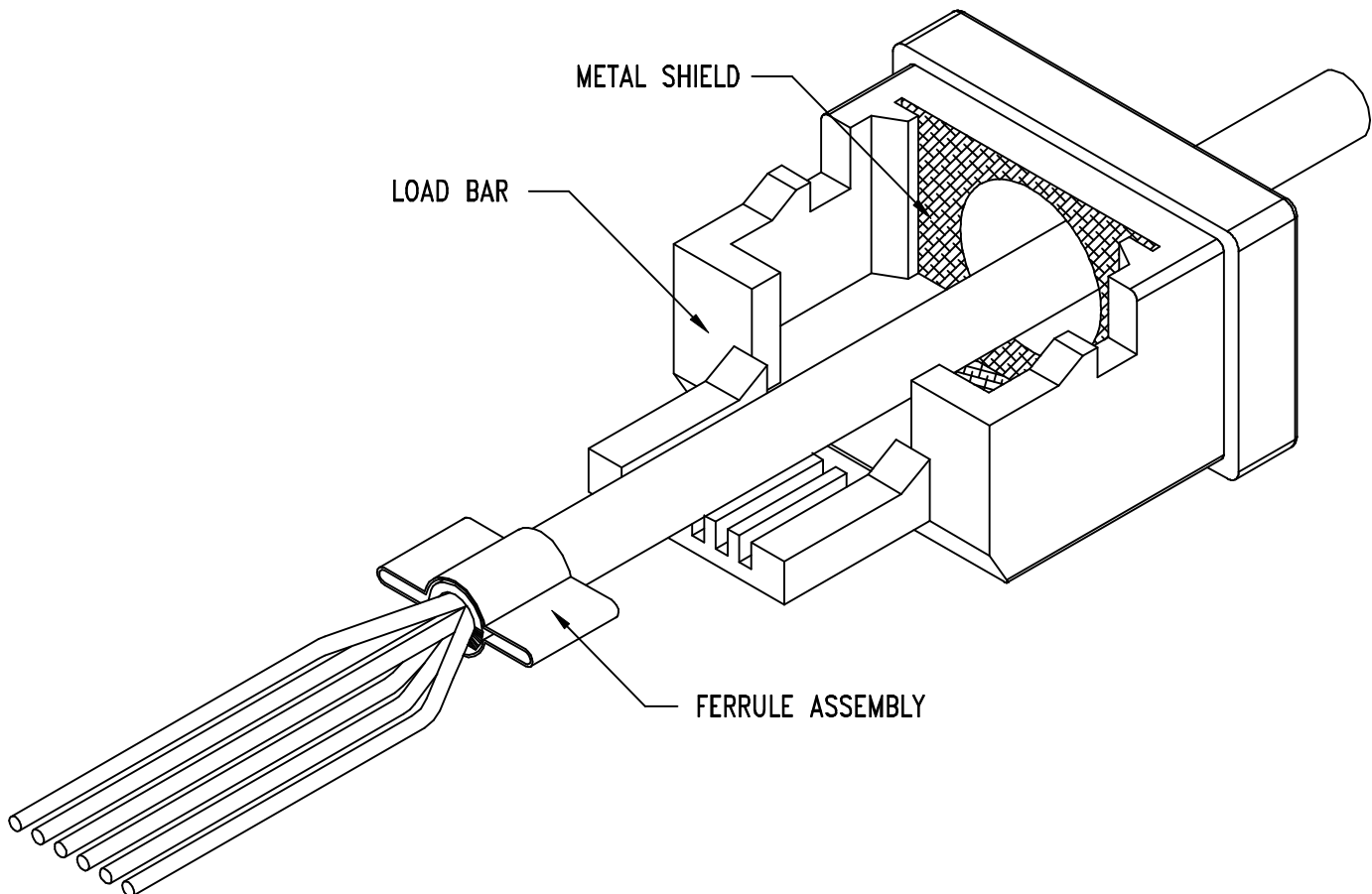

Stewart Connector

BEL STEWART CONNECTOR

11118 Susquehanna Trail South
Glen Rock, PA 17327-9199
(717) 235-7512 Fax: (717) 235-7954
WWW.STEWARTCONNECTOR.COM

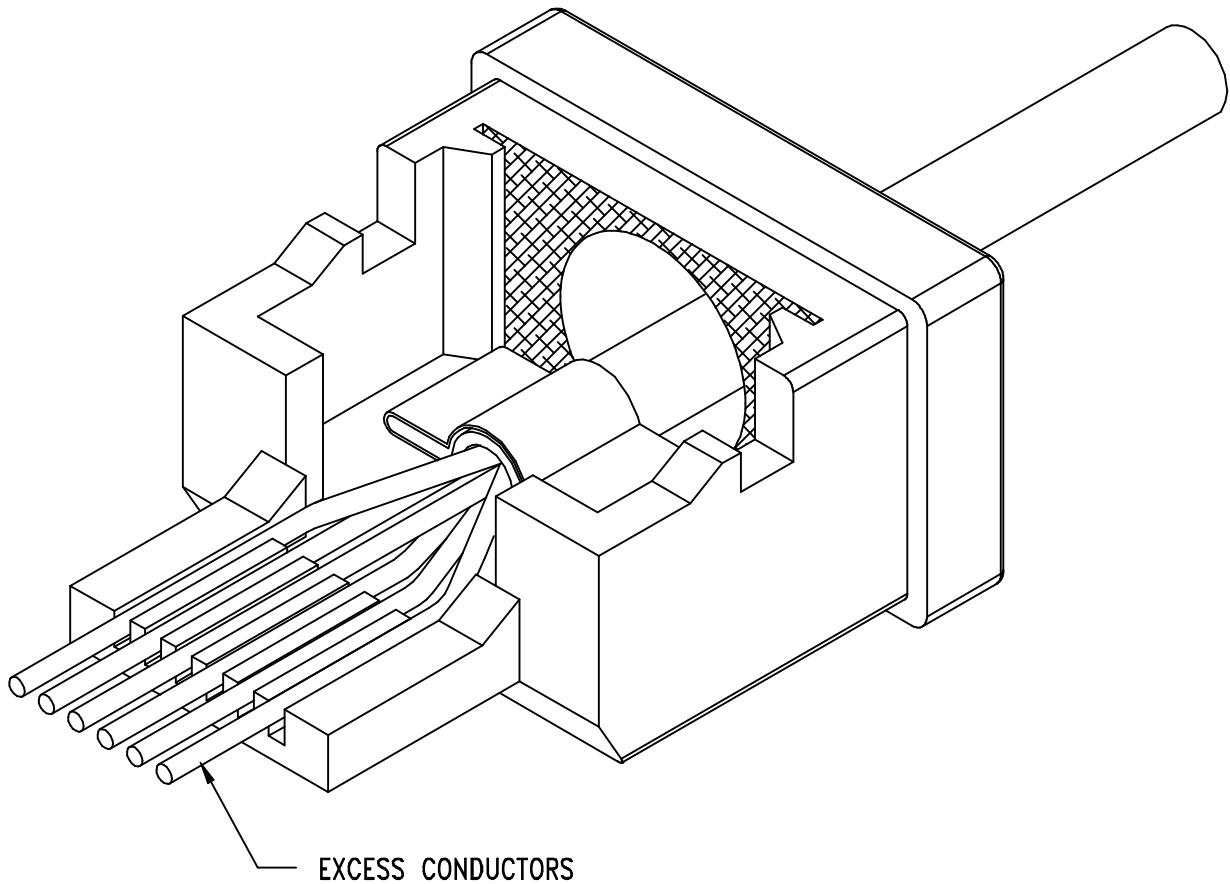

Stewart Connector

BEL STEWART CONNECTOR

11118 Susquehanna Trail South
Glen Rock, PA 17327-9199
(717) 235-7512 Fax: (717) 235-7954
WWW.STEWARTCONNECTOR.COM

11. INSERT LOAD BAR WITH CONDUCTORS AND FERRULE INTO REAR PLASTIC OF CONNECTOR.
12. INSERT LOAD BAR ASSEMBLY INTO TERMINATION HAND TOOL WITH APPROPRIATE DIE-SET AND TERMINATE.

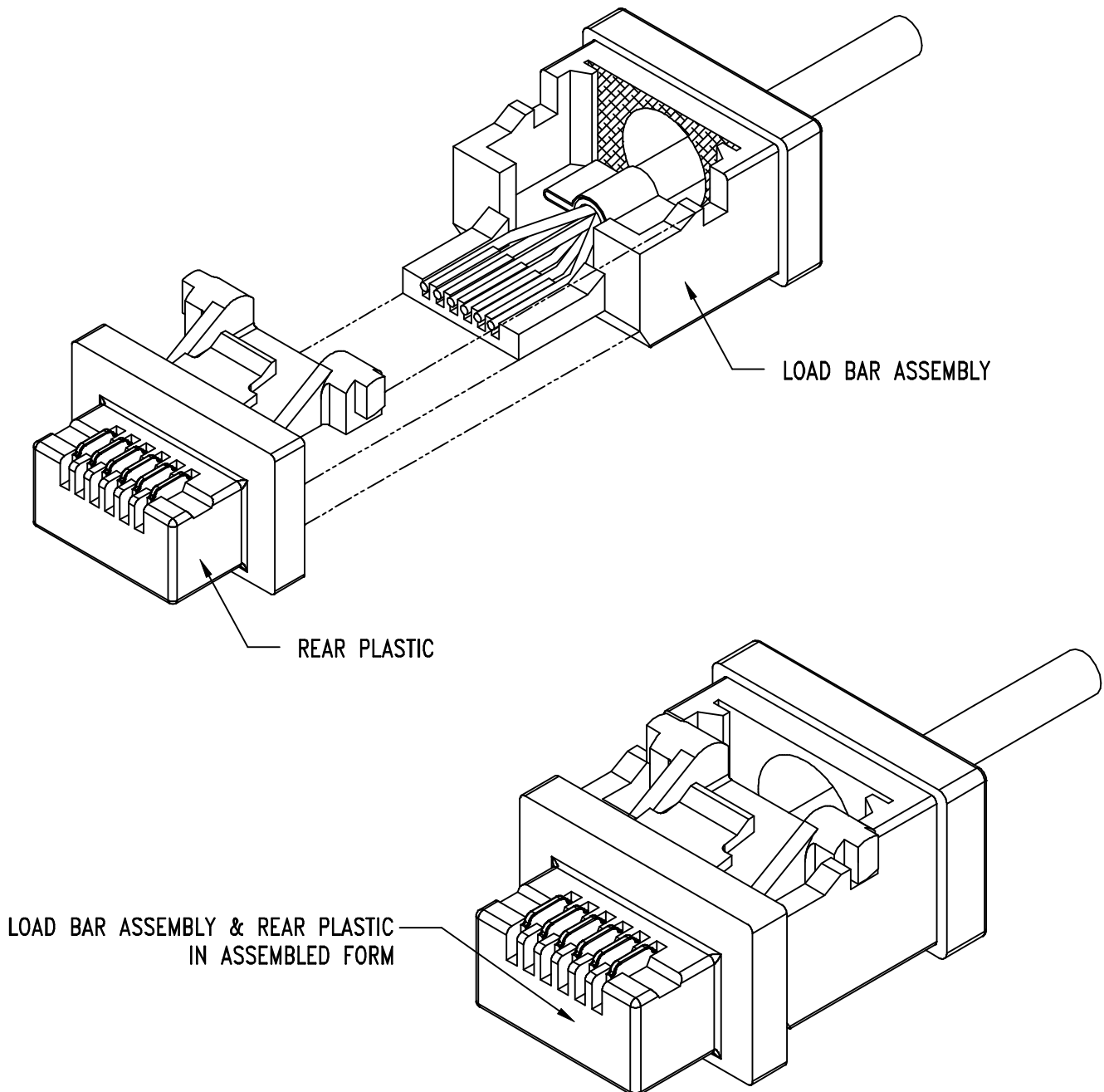

Stewart Connector

BEL STEWART CONNECTOR

11118 Susquehanna Trail South

Glen Rock, PA 17327-9199

(717) 235-7512 Fax: (717) 235-7954

WWW.STEWARTCONNECTOR.COM

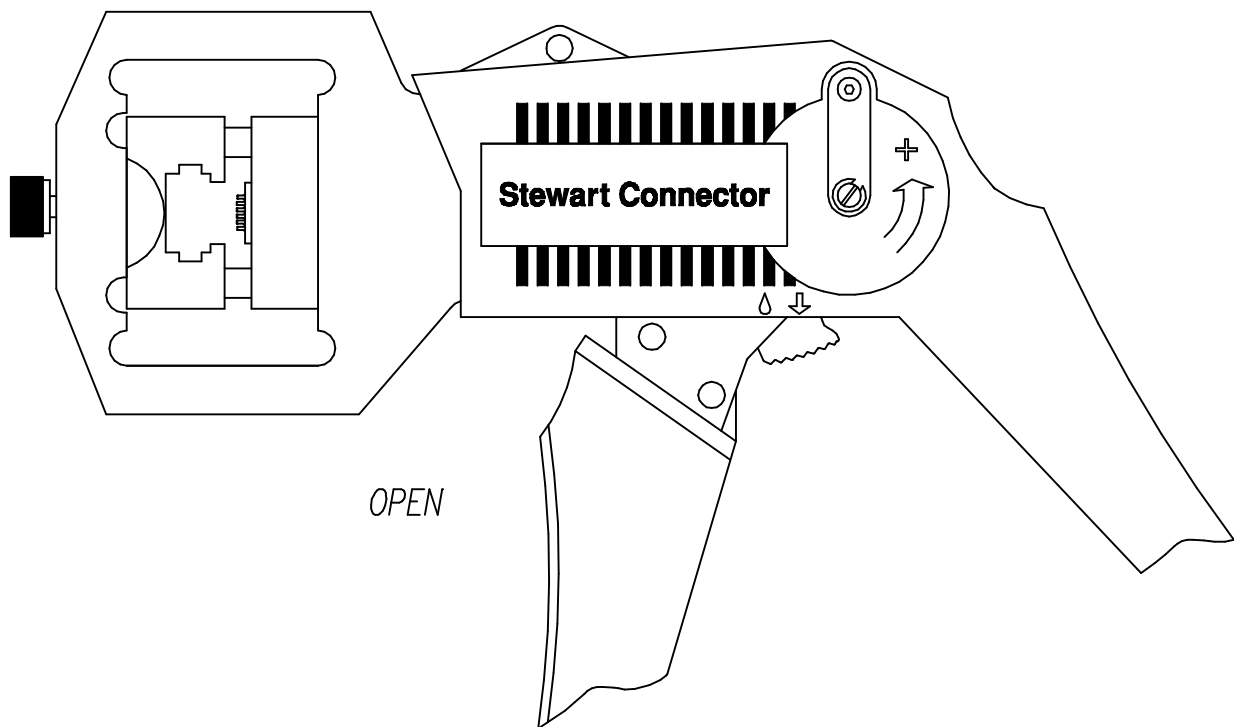
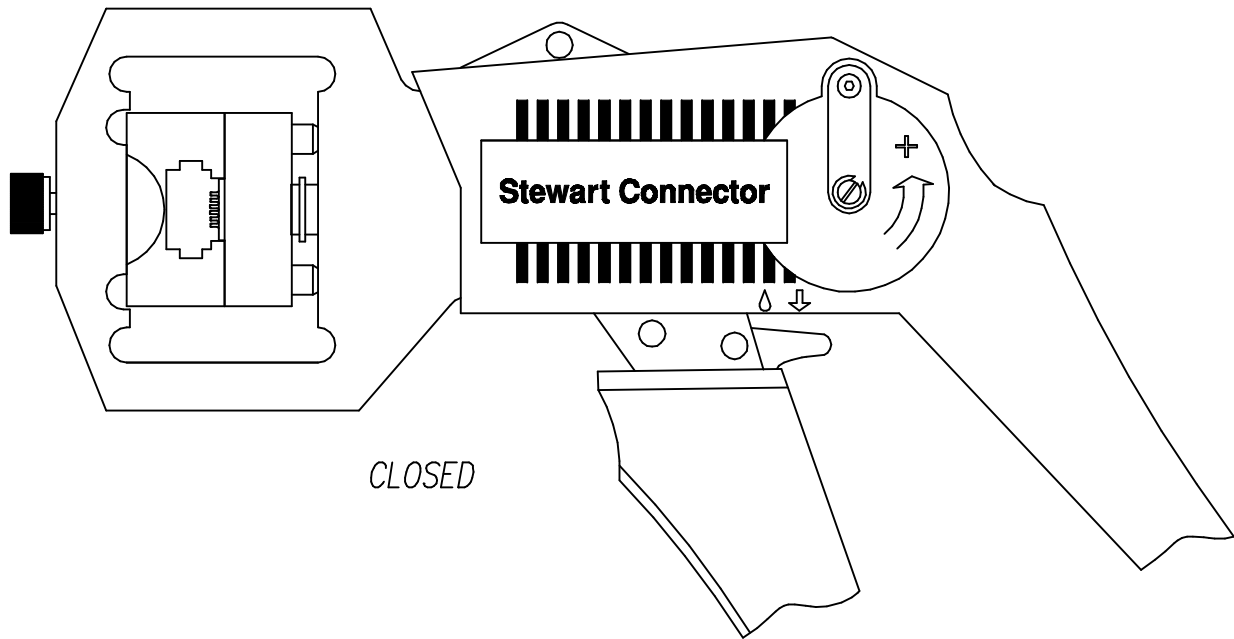

Stewart Connector

BEL STEWART CONNECTOR

11118 Susquehanna Trail South
Glen Rock, PA 17327-9199
(717) 235-7512 Fax: (717) 235-7954
WWW.STEWARTCONNECTOR.COM

13. SNAP REAR PLASTIC ASSEMBLY INTO HOUSING ASSEMBLY AS SHOWN.

