

High-performance, High-reliability 36V Withstand Voltage

BD63xxEFV-EKV-001

1. General Description

1.1 Features

This evaluation board is for ROHM stepping motor drivers BD63715AEFV, BD63725BEFV, BD63525AEFV, BD63511EFV, and BD63521EFV.

The motor can be driven by supplying power to the VCC of the motor driver and 5V power supply for the control signals. An external switch can be used to set drive/stop and excitation modes.

The input interface adopts CLK-IN drive type, and the excitation mode supports FULL STEP, HALF STEP, QUATER STEP, 1/8 STEP, 1/16 STEP mode by built-in DAC.

Lineup of Board support model

Part No.	Max Voltage [V]	Voltage Range [V]	Max Current (DC) [A/Phase]	Max Current (Peak) [A/Phase]	FULL	Half	Quarter	1/8	1/16
BD63715AEFV	36	19 to 28	1.5	2.0	○	○	○		
BD63725BEFV	36	8 to 28	2.5	3.0	○	○	○		
BD63525AEFV	36	8 to 28	2.5	3.0	○	○	○		○
BD63511EFV	36	8 to 28	1.0	1.5	○	○		○	○
BD63521EFV	36	8 to 28	2.0	2.5	○	○		○	○

Table 1. Evaluation Kit Line Up

1.2 Application(Cf. Table 1.)

Each stepping motor drivers

Supply voltage : 8 V to 28 V, 9 V to 28 V

Motor Drive Current : to 3.0 A

Excitation mode : FULL STEP, HALF STEP, QUATER STEP, 1/8 STEP, 1/16 STEP mode

1.3 Appearance of Evaluation Board

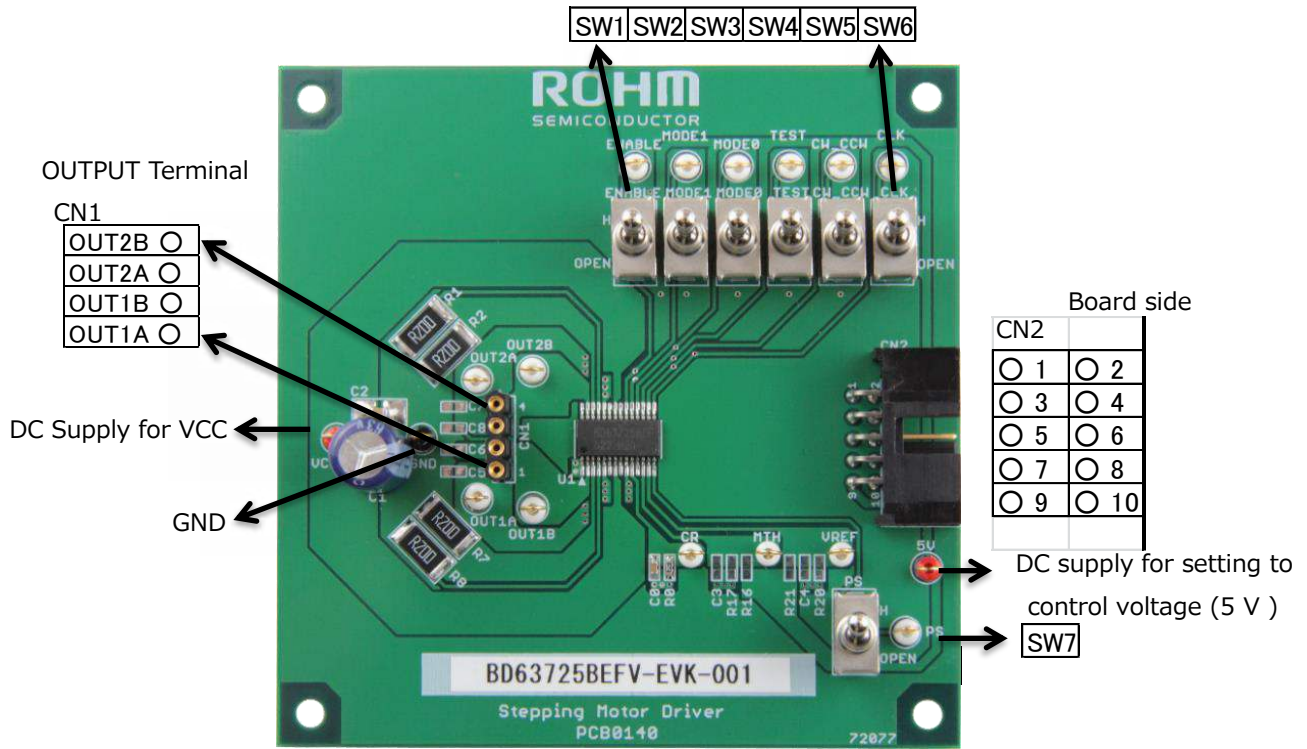

Figure 1. BD63725BEFV-EVK-001 Evaluation Board

Index

1. General Description	1
1.1 Features	1
1.2 Application	1
1.3 Appearance of Evaluation Board	2
2. Product Details	4
2.1 Block Diagram of Driver	4
2.2 Schematic Diagram of Evaluation Board	5
3. Connection and Operation	6
3.1 Necessary Equipment	6
3.2 Connection of stepping motor to Equipment	6
4. Function Setting	7
4.1 ENABLE (ENABLE Terminal)	7
4.2 Power save (P.S.Terminal)	7
4.3 Motor rotating direction setting (CW_CCW Terminal)	7
4.4 Motor excitation mode setting (MODE0,MODE1 Terminal)	7
4.5 Connection terminal of CR for setting chopping frequency (CR Terminal)	8
4.6 Current decay mode setting (MTH Terminal)	8
4.7 Output current value setting (VREF Terminal) , Connection terminal of resister for detecting of output current (RNF1 Terminal,RNF2 Terminal)	8
4.8 Clock input terminal for advancing the electrical angle (CLK Terminal)	9
4.9 Setting of smoothing capacitors in the power supply (C1,C2)	9
5. Operation Explanation	9
5.1 Chopping Operation	9
5.2 Current decay mode	11
6. Evaluation board layout	13
7. Waveforms	15
Revision History	16

2. Product details

2.1 Block Diagram of Driver

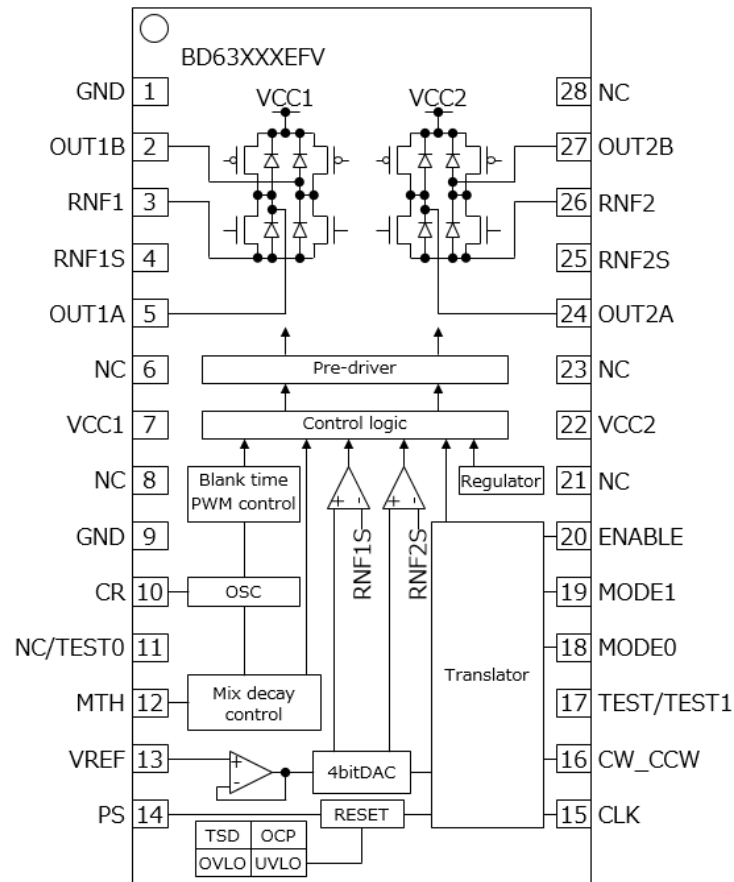

Figure 2. Block Diagram of Driver

Pin No.	Pin name	Function	Pin No.	Pin name	Function
1	GND	Ground terminal	15	CLK	Clock input terminal for advancing the electrical angle
2	OUT1B	H bridge output terminal	16	CW_CCW	Motor rotating direction setting
3	RNF1	Connection terminal of resistor for output current detection	17※1	TEST	Terminal for testing (Used by connecting with GND)
				TEST1	Terminal for testing
4	RNF1S	Input terminal of current detection comparator	18	MODE0	Motor excitation mode setting terminal
5	OUT1A	H bridge output terminal	19	MODE1	Motor excitation mode setting terminal
6	NC	Non connection	20	ENABLE	Output enable terminal
7	VCC1	Power supply terminal	21	NC	Non connection
8	NC	Non connection	22	VCC2	Power supply terminal
9	GND	Ground terminal	23	NC	Non connection
10	CR	Connection terminal of CR for setting chopping frequency	24	OUT2A	H bridge output terminal
11※1	NC	Non connection	25	RNF2S	Input terminal of current detection comparator
	TEST0	Terminal for testing			
12	MTH	Current decay mode setting terminal	26	RNF2	Connection terminal of resistor for output current detection
13	VREF	Output current value setting terminal	27	OUT2B	H bridge output terminal
14	PS	Power save terminal	28	NC	Non connection

※1 upper : BD63715AEFV, BD63725BEFV, BD63525AEFV

lower : BD63511EFV, BD63521EFV

Table 2. Terminal Function table

2.2 Schematic Diagram of Evaluation Board

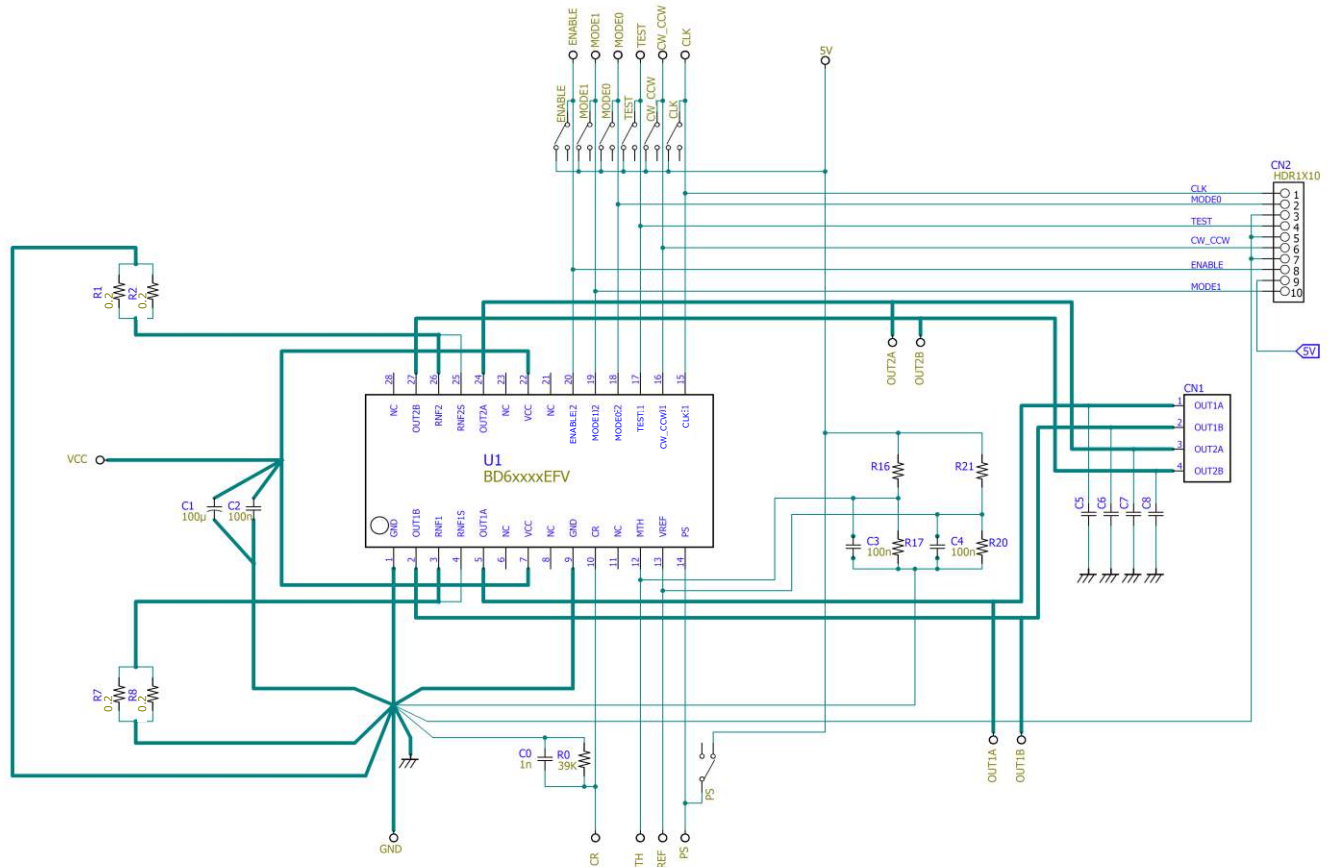

Figure 3. Schematic Diagram of Evaluation Board

Parts	Fixed number	Maker	Product number	Size (unit:mm)	Num	Use
IC1	stepping motor driver	ROHM	BD63715AEFV BD63725BEFV BD63525AEFV BD63511EFV BD63521EFV	9.70x6.40x1.00	1	
C0	1nF	Murata	GCM21BR71H104KA37L	1608	1	Chopping frequency setting
C1	100uF	Nichicon	UVZ1J101MPD1TD	10x12.5	1	Power supply stabilization
C2	100nF	Murata	GCM188R71H102KA3D	2012	1	Power supply stabilization
C3	Nonimplement			1608	1	MTH terminal stabilization
C4	Nonimplement			1608	1	VREF terminal stabilization
C5,C6,C7,C8	Nonimplement			1608	4	
R0	39kΩ	Panasonic	ERJ-3GEYJ393V	1608	1	Chopping frequency setting
R1,R2,R7,R8	0.2Ω	Yaego	RL2512FK-070R2L	6432	4	The resistor for current detection
R16	Nonimplement			1608	1	MTH terminal voltage setting
R17	Nonimplement			1608	1	MTH terminal voltage setting
R20	Nonimplement			1608	1	VREF terminal voltage setting
R21	Nonimplement			1608	1	VREF terminal voltage setting
CN2	10pin	TE connectivity	5104340 -1-ND 5103311		1	

Table 3. Parts list

Please set the MTH voltage by implementing R17 and R16 (Cf. P.8/15).

Please set the VREF voltage by implementing R20 and R21 (Cf. P.8/15).

Please implement C5, C6, C7 and C8 if needed.

3. Connection of Equipment and Operation method

3.1 Necessary Equipment

- Main Power Supply (for VCC : DC Supply under 28V)
- Sub Power Supply (for 5V DC Supply)
- Oscillator for CLK signal(Microcomputer or Function Generator)
- Stepping Motor

3.2 Connection of stepping motor to Equipment

1. Connect the motor (CN1 : OUT1A, OUT1B, OUT2A, OUT2B Terminal).
2. Connect Main Power Supply between the Terminals of Vcc to GND. Please set any voltage (19V to 28V @BD63715AEFV, other 4 are 8V to 28V). Please keep the output to OFF.
3. Connect Main Power Supply between the Terminals of 5V to GND. Set 5V voltage. Please keep the output to OFF.
4. If input CLK Signal, MODE0 Signal, CW_CCW Signal, ENABLE Signal and MODE1 Signal via CN2, set SW6, SW3, SW5 and SW2 to OPEN. Please set TEST Terminal to OPEN.
5. Connect Oscillator to CLK Terminal. Set Signal Level of Oscillator, Lo Level : under 0.6V, Hi Level : the range of 2.8V to 5.0 V. Set any frequency depending on drive speed.
6. Set ENABLE Terminal (SW1), PS Terminal (SW7) to Lo.
7. Turn on the DC Power Supply, and input CLK Signal (The motor won't rotate yet).
8. Set PS Terminal (SW7), ENABLE Terminal (SW1) to Hi (The motor rotate) .
9. If you can check the rotation of motor, please coordinate each setting condition (VREF voltage, MTH voltage) so that a motor is driven optimally. (Cf. P.8/15) .

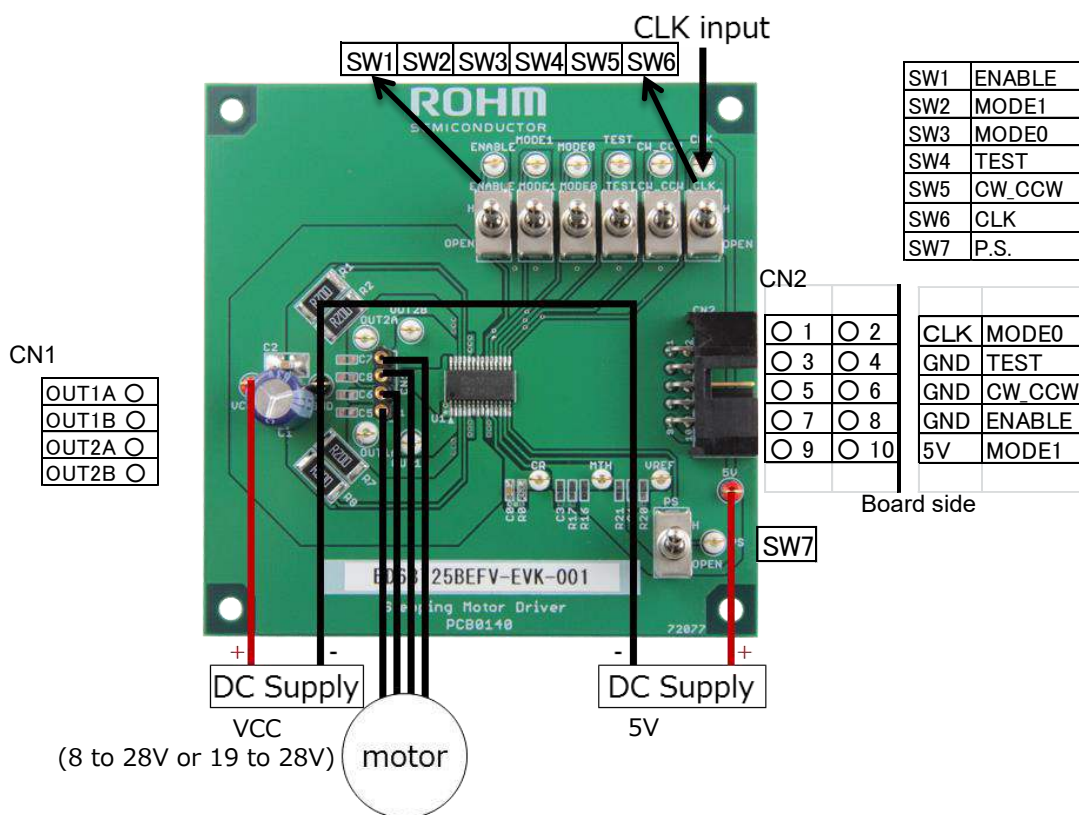

Figure 4. Motor Connection

4. Function Setting

4.1 ENABLE setting (ENABLE Terminal)

By switching SW1 (ENABLE Terminal) to "OPEN", all output transistors are forcibly turned OFF (motor output is open). And by switching to "HI" makes it ACTIVE ($2.0\text{ V} < \text{Hi} < 5.0\text{ V}$, $0.8\text{ V} > \text{Lo}$). This terminal is pull-down to GND by 100 k Ω inside the IC. This board is equipped with 5V/OPEN SW.

When ENABLE=L, input to CLK is blocked, and phase advance operation of internal translator circuit is stopped.

However, if the excitation mode (MODE0, MODE1) is switched in the ENABLE=L interval, as ENABLE is reset to HI, the new excitation mode will be applied.

ENABLE	Motor Output
L	OPEN (electrical angle maintained)
H	ACTIVE

4.2 Power save setting (PS Terminal)

By switching SW7 (PS Terminal) to "OPEN", PS can make the circuit in standby state and the motor output open.

In standby state, translator circuit is RESET and electrical angle is initialized. And by switching to "Hi" makes it ACTIVE. ($2.0\text{ V} < \text{Hi} < 5.0\text{ V}$, $0.8\text{ V} > \text{Lo}$). This terminal is pull-down to GND by 100 k Ω inside the IC. This board is equipped with 5V/OPEN SW.

When PS=OPEN and switched to HI, please note that there is a delay of 40 μs (Max) before it is returned from standby state to normal state and the motor output becomes ACTIVE.

PS	Status
L	Standby state (RESET)
H	ACTIVE

The electrical angle (initial electrical angle) of each excitation mode immediately after RESET is 45° .

4.3 Motor rotating direction setting (CW_CCW Terminal)

By switching SW5 (CW_CCW Terminal) to "Hi" or "OPEN", direction of rotation of motor can be set. ($2.0\text{ V} < \text{Hi} < 5.0\text{ V}$, $0.8\text{ V} > \text{Lo}$).

This terminal is pull-down to GND by 100 k Ω inside the IC. Change in setting is reflected at the CLK rising edge immediately after the change in setting.

CW_CCW	Rotating direction
L	Clockwise (CH2's current is outputted with a phase lag of 90° in regard to CH1's current)
H	Counter Clockwise(CH2's current is outputted with a phase lead of 90°in regard to CH1's current)

4.4 Motor excitation mode setting (MODE0, MODE1 Terminal)

By switching SW2 (MODE 0 Terminal) and SW3 (MODE 1 Terminal) to "Hi" or "OPEN", motor excitation mode can be set ($2.0\text{ V} < \text{Hi} < 5.0\text{ V}$, $0.8\text{ V} > \text{Lo}$). This terminal is pull-down to GND by 100 k Ω inside the IC.

MODE0	MODE1	BD63715AEFV	BD63725BEFV	BD63525AEFV	BD63511EFV	BD63521EFV
L	L	FULL A		FULL B		
L	H	HALF A		HALF C		
H	L	HALF B		Quarter	1/8	
H	H	Quarter		1/16		

4.5 CR chopping frequency setting (CR Terminal)

You can set frequency of the output by a capacitor (C0) and resistor (R0) to be connected between CR terminal to GND. Please connect the external C0 (470p to 1500pF) and R0 (10k to 200kΩ) between this terminal and GND. This board is connected with C0 = 1000 pF, R0 = 39 KΩ. Chopping frequency is set to about 24.5kHz. When it is open or it is biased from the outside, it is not possible to control normal PWM constant current, so if it is used in PWM constant current control, always put both C and R parts.

4.6 Current decay mode setting (MTH Terminal)

Current decay mode can be optionally set according to input voltage for MTH terminal.
(SLOW DECAY / MIX DECAY / FAST DECAY).

MTH terminal input voltage [V]	Current decay mode
0.0 to 0.3	SLOW DECAY
0.4 to 1.0	MIX DECAY
1.5 to 3.5	FAST DECAY

The input voltage of this board can be set with a division level of 5V by the resistor (R17, R16) to be connected between 5V – GND. This board does not implement R16, R17. Please adjust it while confirming motor drive. Please connect the capacitor C34 between MTH terminal - GND when the terminal voltage is unstable. Connect to GND if using at SLOW DECAY mode. Avoid using with the MTH Terminal open because if the MTH Terminal is open, the input is unsettled, and then there is the danger that PWM operation becomes unstable. Besides, take into consideration the outflowcurrent (Max2 μA) if the input used is a resistor divider.

4.7 Output current value setting (VREF Terminal),

Connection terminal of resistor for detecting of output current (RNF1 Terminal,RNF2 Terminal)

This is the terminal to set the output current value. The output current value (max value) can be set by VREF voltage (R20, R21, C4) and current-detecting resistor (RNF resistor, R1, R2, R7, R8).

This board does not implement R20, R21, C4.

The VREF terminal input voltage is set with a division level of 5V by the resistance (R20, R21) to be connected between 5V – GND. Please set the the output current in reference to the following setting method. Please connect the capacitor C4 between VREF terminal - GND when the terminal voltage is unstable.

And the resistor for detecting of current can be set by R1, R2, R7, R8, this board is connected R1 = R2 = R7 = R8 =0.2 Ω.

<How to set output current value>

The output current can be set by VREF voltage and resistor for detecting of output current (RNF resistance) .

BD63525AEFV, BD63511EFV, BD63521EFV FULL STEP only

$$\text{Output current } I_{\text{OUT}} [\text{A}] = \{ \text{VREF} [\text{V}] / 5 (\text{division ratio inside IC}) \} \times 0.7071 / \text{RNF} [\Omega]$$

BD63525AEFV, BD63511EFV, BD63521EFV other than FULL STEP

$$\text{Output current } I_{\text{OUT}} [\text{A}] = \{ \text{VREF} [\text{V}] / 5 (\text{division ratio inside IC}) \} / \text{RNF} [\Omega]$$

Avoid using the VREF Terminal open because input voltage becomes unsettled, and the VREF voltage increases, and then the set current increases and a large current flows which may cause malfunction. Keep to the input voltage range because if voltage above 3V is applied on the VREF Terminal, then there is also the danger that a large current flows in the output and so OCP or TSD will operate. Besides, take into consideration the outflow current (Max 2μA) if the input used is a resistor divider. The minimum current, which can be controlled by VREF voltage, is determined by motor coil's L, R values and minimum ON time because there is a minimum ON time in PWM drive.

4.8 Clock input for advancing the electrical angle (CLK Terminal)

Trigger is CLK's rising edge. The Electrical angle advances by one for each CLK input(2.8 V < Hi < 5.0 V, 0.6 V < Lo). This terminal is pull-down to GND by 100 kΩ inside the IC.

4.9 Setting of smoothing capacitors in the power supply (C1, C2)

Please change the capacitance of the electrolytic capacitor (C1) of the power supply part, the ceramic capacitor (C2) depending on the drive situation.

This evaluation board is connected with C1 = 100 μF, C2 = 0.1 μF.

5. Operation Explanation

5.1 Chopping Operation

The external capacitor(C0) and resistor(R0) connected to the CR Terminal is repeatedly charged and discharged between the V_{CRH} and V_{CRL} levels. The output of the current detection comparator is masked while charging from V_{CRL} to V_{CRH}. As mentioned above, this period defines the minimum ON-time. The CR Terminal begins discharging once the voltage reaches V_{CRH}. When the output current reaches the current limit during this period, then the IC enters decay mode. The CR continues to discharge during this period until it reaches V_{CRL}, at which point the IC output is switched back ON. The current output and the CR Terminal begin charging simultaneously. The CR charge time (t_{ONMIN}) and discharge time (t_{DISCHARGE}) are set by external components, according to the following formulas. The total of t_{ONMIN} and t_{DISCHARGE} yield the chopping period, t_{CHOP}.

$$t_{ONMIN}[s] \doteq C0 \cdot R' \cdot R0 / (R' + R0) \cdot \ln[(VCR - 0.4)/(VCR - 1.0)]$$

$$VCR = V \cdot R0 / (R' + R0)$$

V : internal regulator voltage 5V(typ)

R' : CR terminal internal impedance 5kΩ(typ)

$$t_{DISCHARGE}[s] \doteq C0 \cdot R0 \cdot \ln[(1 + \alpha)/0.4]$$

α: See the right graph.

$$t_{CHOP}[s] \doteq t_{ONMIN} + t_{DISCHARGE}$$

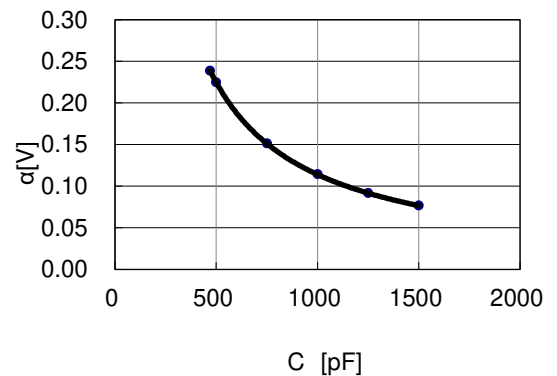

Figure 5. C vs α

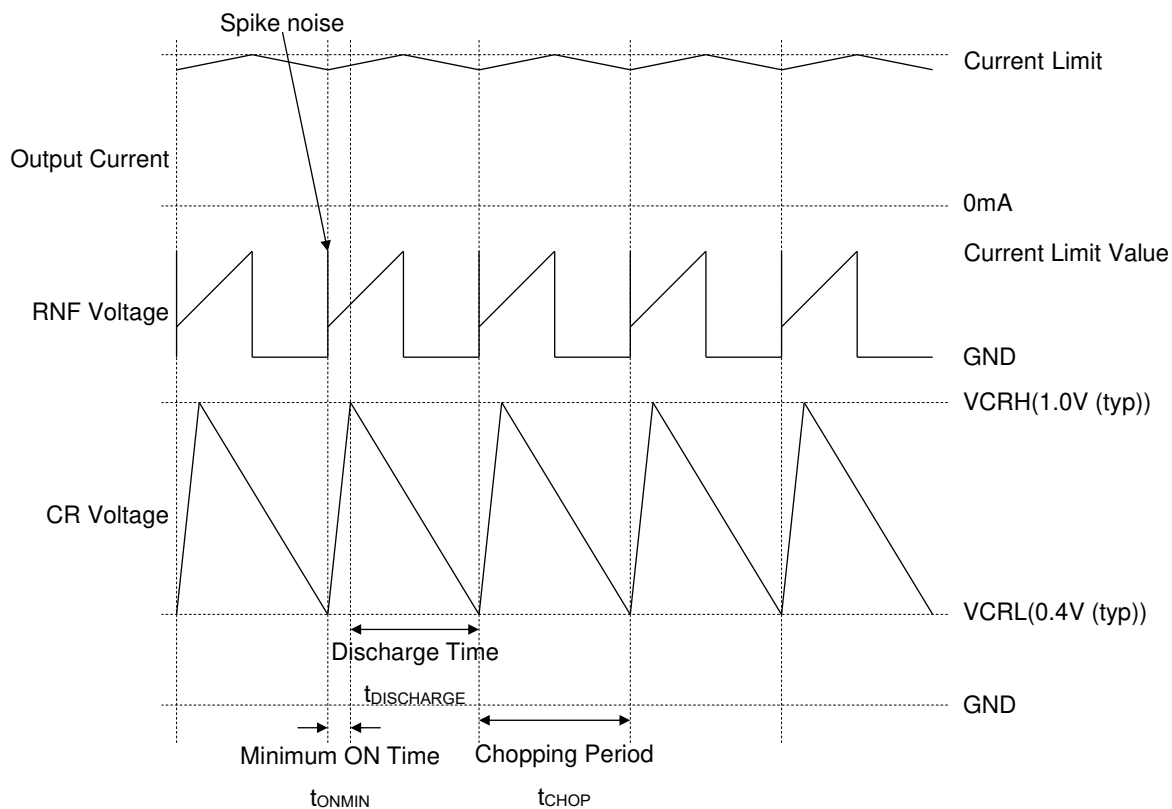

Figure 6. Timing chart of CR Voltage, RNF Voltage and Output Current

Attach a resistor of at least 10 k Ω to the CR Terminal (10 k Ω to 200 k Ω recommended) as lower values may keep the CR from reaching the V_{CRH} voltage level. A capacitor in the range of 470 pF to 1500 pF is also recommended. Using capacitance value of several thousand pF or more, however, the noise-masking period (t_{ONMIN}) also increases, and there is a risk that the output current may exceed the setting value due to the internal L and R components of the output motor coil. Also, ensure that the chopping period (t_{CHOP}) is not set longer than necessary, as doing so will increase the output ripple, thereby decreasing the average output current and yielding lower output rotation efficiency. Select optimal value so that motor drive sound, and distortion of output current waveform can be minimized.

5.2 Current decay mode

PWM Constant Current Control can be optionally set the current decay mode in which the ratio of fast and slow decay.

The following diagrams show the state of each transistor and the regenerative current path during the current decay for each decay mode.

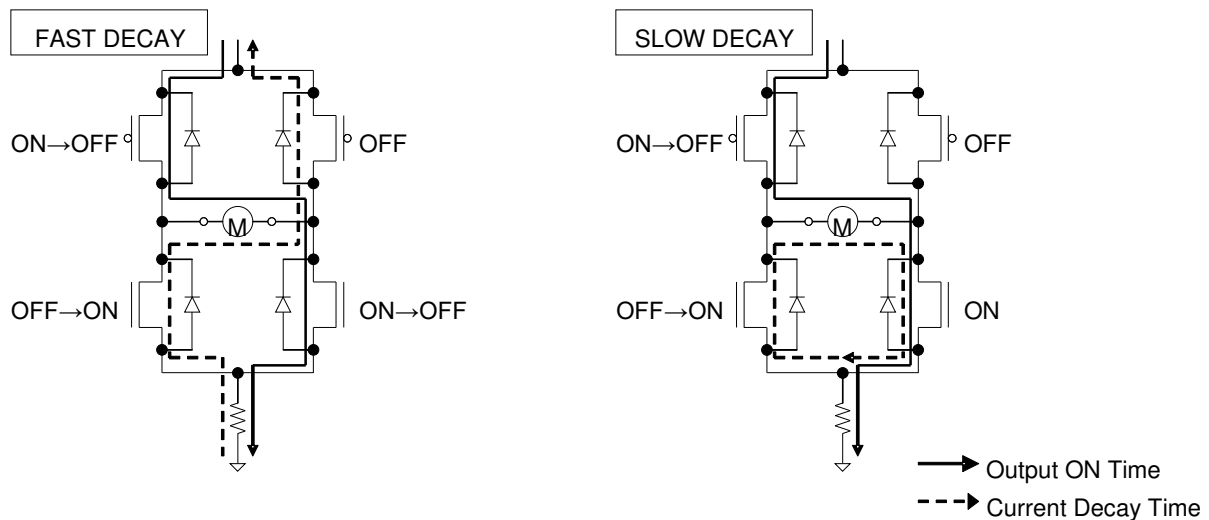

Figure 7. Route of Regenerated Current during Current Decay

The merits of each decay mode are as follows:

○SLOW DECAY

The output current ripple is small and this is favorable for keeping motor torque high because the voltage between the motor coils is small and the regenerative current decreases slowly. However, an increase in the output current due to deterioration of the current control in the lower current operation in HALF STEP, QUARTERSTEP, 1/8 STEP, 1/16 STEP, due to the influence of the motor reverse electromotive voltage during high pulse rate driving in the mode, the current waveform is not able to follow the change in the current limit and the distortion and motor vibration increases. Thus, this decay mode is suited to FULL STEP mode or low-pulse-rate driven HALF STEP, QUARTER STEP, 1/8 STEP or 1/16 STEP modes.

○FAST DECAY

Fast decay decreases the regeneration current much more quickly than slow decay, reducing distortion of the output current waveform. However, fast decay yields a much larger output current ripple, which decreases the overall average current running through the motor. This causes two problems: first, the motor torque decreases (increasing the current limit value can help eliminate this problem, but the rated output current must be taken into consideration); and second, the power loss within the motor increases and thereby radiates more heat. If neither of these problems is of concern, then fast decay can be used for high-pulse rate HALF STEP, QUARTER STEP, 1/8 STEP or 1/16 STEP drive.

Additionally, this IC allows for a mixed decay mode that can help improve upon problems that arise from using fast or slow decay alone. During current decay switching between SLOW DECAY and FAST DECAY can improve current control without increasing the current ripple. In addition, the time ratio of SLOW DECAY and FAST DECAY can be changed by the voltage input to the MTH Terminal, and it is possible to achieve optimal control state for any motor. During MIX DECAY mode about chopping cycle, the first (t_1 to t_2) of which operates the IC in SLOW DECAY mode, and the remainder (t_2 to t_3) of which operates in FAST DECAY mode. However, if the output current does not reach the set current limit during the first (t_1 to t_2) decay period, the IC operates in fast decay mode only.

MTH terminal input voltage [V]	Current decay mode
0.0 to 0.3	SLOW DECAY
0.4 to 1.0	MIX DECAY
1.5 to 3.5	FAST DECAY

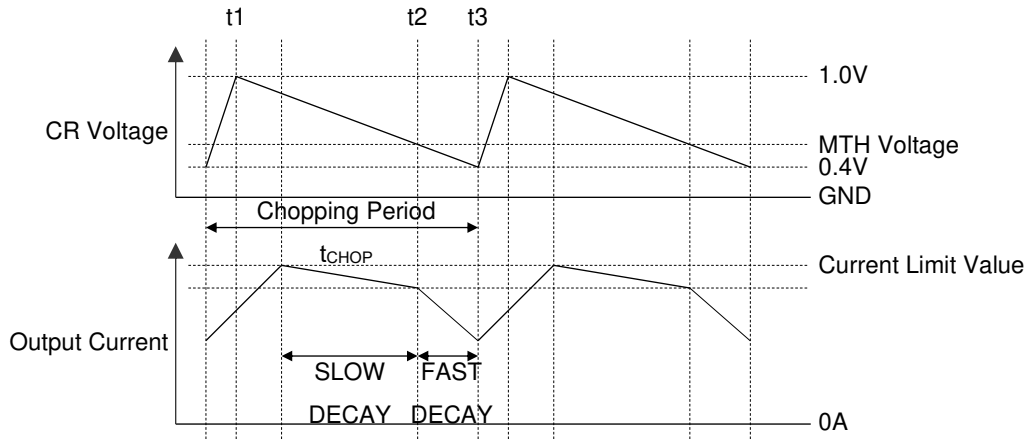

Figure 8. CR voltage and output current at MIX DECAY

6. Evaluation Board Layout

Board size : 80mm x 80mm x 1.6mm (4 Layer)

material : FR-4

Copper foil : 35 μm thickness

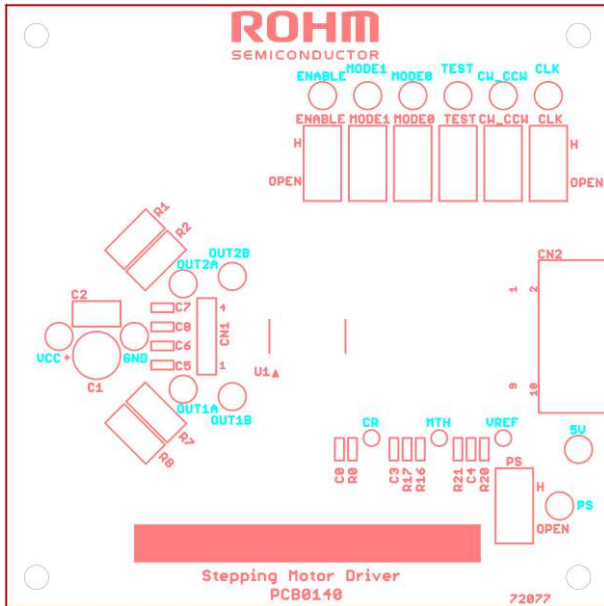

Figure 9. Evaluation board (Silkscreen)

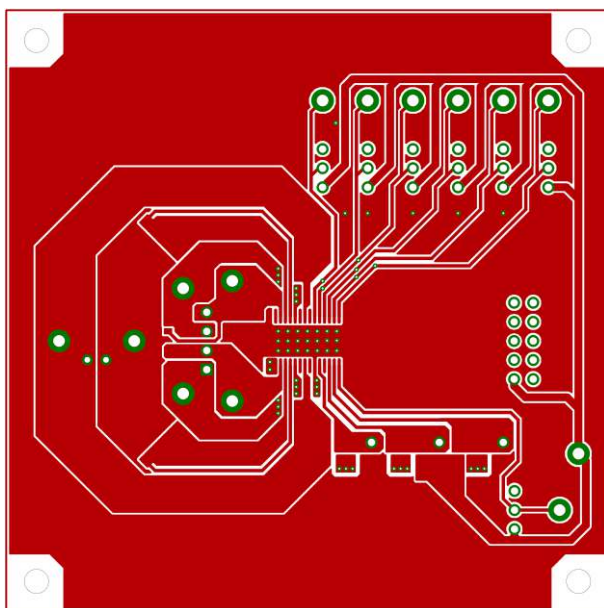

Figure 10. Evaluation board (Top Layer)

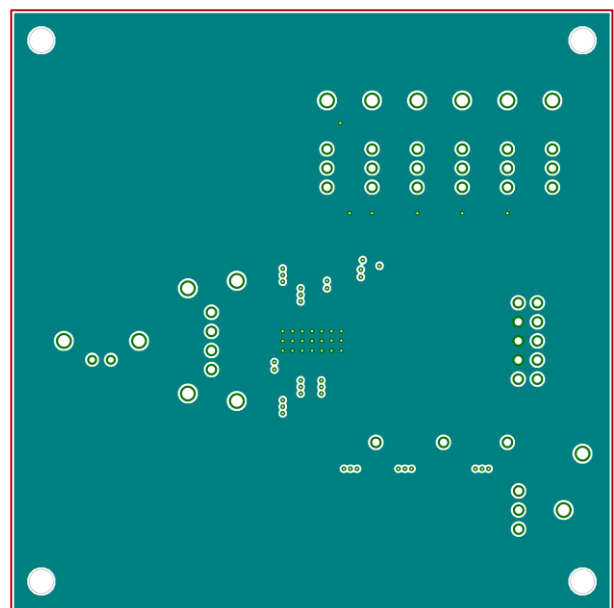

Figure 11. Evaluation board (Mid Layer1)

Evaluation board Layout – continued

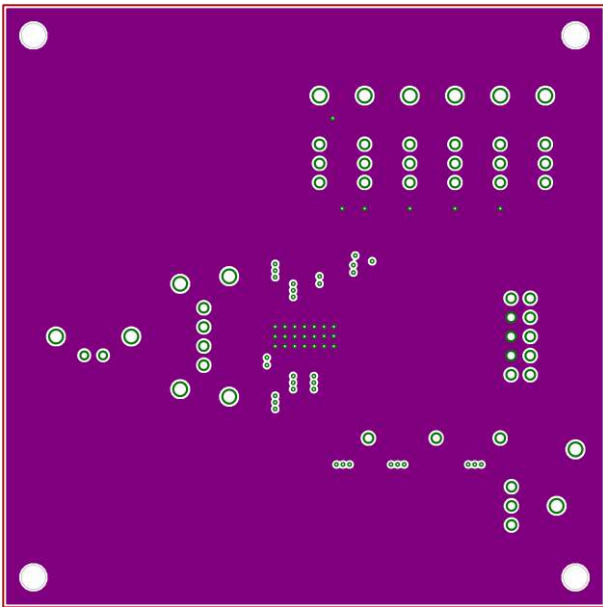

Figure 12. Evaluation board (Mid Layer2)

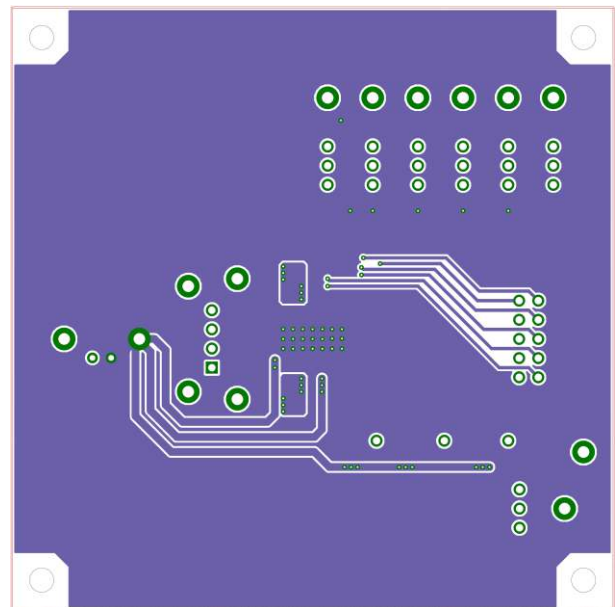

Figure 13. Evaluation board (Bottom Layer)

7. Driving Waveforms

Conditions : VCC = 24 V, VREF = 0.5 V, MTH = 0.5 V, CR = 39 kΩ / 1000 pF, RNF = 0.1 Ω



Figure 14. FULL STEP (CLK : 600 Hz)

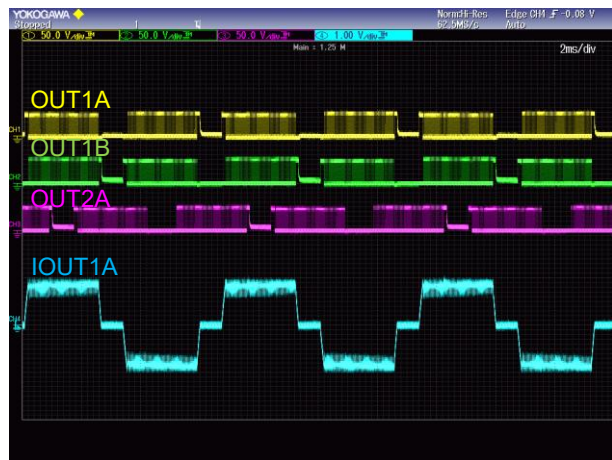

Figure 15. HALF STEP A (CLK : 1200 Hz)



Figure 16. HALF STEP B (CLK : 1200Hz)



Figure 17. QUARTER STEP (CLK : 2400Hz)

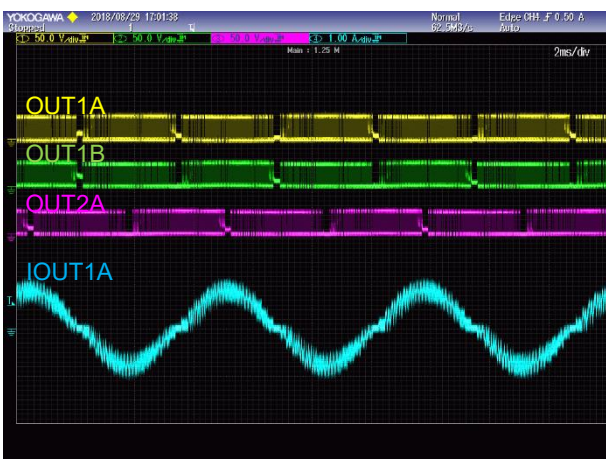

Figure 18. 1/8 STEP (CLK : 4800Hz)

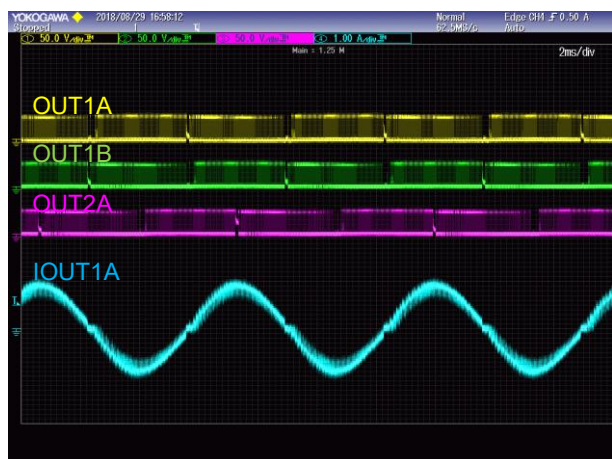

Figure 19. 1/16 STEP (CLK : 9600Hz)

Revision History

Date	Revision	Changes
26.Apr.2021	002	New Release

Notes

- 1) The information contained herein is subject to change without notice.
- 2) Before you use our Products, please contact our sales representative and verify the latest specifications :
- 3) Although ROHM is continuously working to improve product reliability and quality, semiconductors can break down and malfunction due to various factors.
Therefore, in order to prevent personal injury or fire arising from failure, please take safety measures such as complying with the derating characteristics, implementing redundant and fire prevention designs, and utilizing backups and fail-safe procedures. ROHM shall have no responsibility for any damages arising out of the use of our Products beyond the rating specified by ROHM.
- 4) Examples of application circuits, circuit constants and any other information contained herein are provided only to illustrate the standard usage and operations of the Products. The peripheral conditions must be taken into account when designing circuits for mass production.
- 5) The technical information specified herein is intended only to show the typical functions of and examples of application circuits for the Products. ROHM does not grant you, explicitly or implicitly, any license to use or exercise intellectual property or other rights held by ROHM or any other parties. ROHM shall have no responsibility whatsoever for any dispute arising out of the use of such technical information.
- 6) The Products specified in this document are not designed to be radiation tolerant.
- 7) For use of our Products in applications requiring a high degree of reliability (as exemplified below), please contact and consult with a ROHM representative : transportation equipment (i.e. cars, ships, trains), primary communication equipment, traffic lights, fire/crime prevention, safety equipment, medical systems, servers, solar cells, and power transmission systems.
- 8) Do not use our Products in applications requiring extremely high reliability, such as aerospace equipment, nuclear power control systems, and submarine repeaters.
- 9) ROHM shall have no responsibility for any damages or injury arising from non-compliance with the recommended usage conditions and specifications contained herein.
- 10) ROHM has used reasonable care to ensure the accuracy of the information contained in this document. However, ROHM does not warrants that such information is error-free, and ROHM shall have no responsibility for any damages arising from any inaccuracy or misprint of such information.
- 11) Please use the Products in accordance with any applicable environmental laws and regulations, such as the RoHS Directive. For more details, including RoHS compatibility, please contact a ROHM sales office. ROHM shall have no responsibility for any damages or losses resulting non-compliance with any applicable laws or regulations.
- 12) When providing our Products and technologies contained in this document to other countries, you must abide by the procedures and provisions stipulated in all applicable export laws and regulations, including without limitation the US Export Administration Regulations and the Foreign Exchange and Foreign Trade Act.
- 13) This document, in part or in whole, may not be reprinted or reproduced without prior consent of ROHM.



Thank you for your accessing to ROHM product informations.
More detail product informations and catalogs are available, please contact us.

ROHM Customer Support System

<http://www.rohm.com/contact/>