

- 1
- 2
- 3
- 4
- 5
- 6
- 7
- 8
- 9
- 10
- 11
- 12
- 13
- 14
- 15
- 16
- 17
- 18

STANDARD EXECUTIONS

- LM-TR:

zinc-plated steel base and ball joint with threaded blind hole.
zinc-plated steel base and ball joint with threaded stem and nut.

- LM-SST-TR:

AISI 303 stainless steel base and ball joint with threaded blind hole.
AISI 303 stainless steel base and ball joint with threaded stem.
AISI 304 stainless steel nut.

NO-SLIP COATING

Thermoplastic elastomer (TPE).

FEATURES

The resistance of the levelling element to a static load is obviously limited by the load capacity of the stem.

The static load values in the table below refer to the resistance to a load applied on the axis of the levelling foot.

Under common working conditions, side or angular loading increases the stress on the stem and reduces its load capacity.

To increase the applicable load you can use the ball joint with threaded hole by inserting a steel threaded bar of higher resistance class. We recommend to insert a pressure pad between the end of the bar and the bottom of the threaded hole to reduce loading on the threading.



Conversion Table	
1 mm = 0.039 inch	
D	
mm	inch
25	0.98
32	1.26
40	1.57
50	1.97
60	2.36

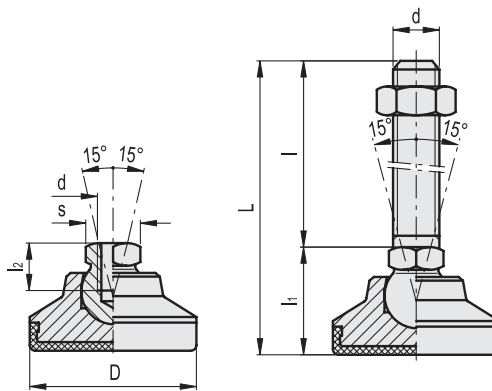

LM.TR (d)

METRIC

LM-SST-TR (d)

INOX STAINLESS STEEL

METRIC

Code	Description	D	d	l1	l2	s	Max. limit static load [N]	⚖️	Code	Description	Max. limit static load [N]	⚖️
401220	LM.25 M6-TR	25	M6	20.5	9	12	7500	40	402220	LM.25-SST M6-TR	4000	40
401221	LM.25 M8-TR	25	M8	20.5	9	12	14000	35	402221	LM.25-SST M8-TR	7000	36
401230	LM.32 M8-TR	32	M8	24.5	9	12	14000	85	402230	LM.32-SST M8-TR	7000	85
401231	LM.32 M10-TR	32	M10	24.5	10.5	15	23000	75	402231	LM.32-SST M10-TR	11000	77
401240	LM.40 M10-TR	40	M10	27.5	10.5	15	23000	120	402240	LM.40-SST M10-TR	11000	120
401241	LM.40 M12-TR	40	M12	27.5	11.5	17	33000	110	402241	LM.40-SST M12-TR	16000	113
401250	LM.50 M10-TR	50	M10	29.5	10.5	15	23000	170	402250	LM.50-SST M10-TR	11000	185
401251	LM.50 M12-TR	50	M12	29.5	11.5	17	33000	160	402251	LM.50-SST M12-TR	16000	165
401260	LM.60 M12-TR	60	M12	37.5	11.5	17	33000	335	402260	LM.60-SST M12-TR	16000	335
401261	LM.60 M16-TR	60	M16	37.5	16	24	62000	320	402261	LM.60-SST M16-TR	30000	330

Levelling feet and supports



LM.TR (d - l)

METRIC

LM-SST-TR (d - l)

INOX STAINLESS STEEL

METRIC

Code	Description	D	d	L	l	l ₁	s	Max. limit static load [N]		Code	Description	Max. limit static load [N]	
401713	LM.25 M6x40-TR	25	M6	60.5	40	20.5	12	7500	39	402711	LM.25-SST M6x40-TR	4000	39
401714	LM.25 M6x50-TR	25	M6	70.5	50	20.5	12	7500	41	402712	LM.25-SST M6x50-TR	4000	41
401715	LM.25 M6x63-TR	25	M6	83.5	63	20.5	12	7500	45	402713	LM.25-SST M6x63-TR	4000	45
401723	LM.25 M8x40-TR	25	M8	60.5	40	20.5	12	14000	66	402723	LM.25-SST M8x40-TR	7000	68
401724	LM.25 M8x50-TR	25	M8	70.5	50	20.5	12	14000	50	402724	LM.25-SST M8x50-TR	7000	50
401726	LM.25 M8x63-TR	25	M8	83.5	63	20.5	12	14000	70	402726	LM.25-SST M8x63-TR	7000	72
401716	LM.25 M10x50-TR	25	M10	70.5	50	20.5	12	23000	54	402716	LM.25-SST M10x50-TR	11000	54
401717	LM.25 M10x63-TR	25	M10	83.5	63	20.5	12	23000	64	402717	LM.25-SST M10x63-TR	11000	64
401718	LM.25 M10x80-TR	25	M10	100.5	80	20.5	12	23000	76	402718	LM.25-SST M10x80-TR	11000	76
401730	LM.32 M8x40-TR	32	M8	64.5	40	24.5	12	14000	52	402730	LM.32-SST M8x40-TR	7000	52
401731	LM.32 M8x50-TR	32	M8	74.5	50	24.5	12	14000	57	402731	LM.32-SST M8x50-TR	7000	57
401732	LM.32 M8x63-TR	32	M8	87.5	63	24.5	12	14000	67	402732	LM.32-SST M8x63-TR	7000	67
401733	LM.32 M10x50-TR	32	M10	74.5	50	24.5	15	23000	106	402733	LM.32-SST M10x50-TR	11000	109
401734	LM.32 M10x63-TR	32	M10	87.5	63	24.5	15	23000	112	402734	LM.32-SST M10x63-TR	11000	112
401736	LM.32 M10x80-TR	32	M10	104.5	80	24.5	15	23000	120	402736	LM.32-SST M10x80-TR	11000	124
401727	LM.32 M12x63-TR	32	M12	87.5	63	24.5	15	33000	166	402727	LM.32-SST M12x63-TR	16000	166
401728	LM.32 M12x80-TR	32	M12	104.5	80	24.5	15	33000	183	402728	LM.32-SST M12x80-TR	16000	183
401729	LM.32 M12x100-TR	32	M12	124.5	100	24.5	15	33000	201	402729	LM.32-SST M12x100-TR	16000	201
401737	LM.40 M8x50-TR	40	M8	77.5	50	27.5	15	14000	142	402737	LM.40-SST M8x50-TR	7000	142
401738	LM.40 M8x63-TR	40	M8	90.5	63	27.5	15	14000	150	402738	LM.40-SST M8x63-TR	7000	150
401739	LM.40 M8x80-TR	40	M8	107.5	80	27.5	15	14000	158	402739	LM.40-SST M8x80-TR	7000	158
401740	LM.40 M10x50-TR	40	M10	77.5	50	27.5	15	23000	157	402740	LM.40-SST M10x50-TR	11000	157
401741	LM.40 M10x63-TR	40	M10	90.5	63	27.5	15	23000	165	402741	LM.40-SST M10x63-TR	11000	165
401742	LM.40 M10x80-TR	40	M10	107.5	80	27.5	15	23000	172	402742	LM.40-SST M10x80-TR	11000	172
401743	LM.40 M12x63-TR	40	M12	90.5	63	27.5	17	33000	178	402743	LM.40-SST M12x63-TR	16000	183
401744	LM.40 M12x80-TR	40	M12	107.5	80	27.5	17	33000	190	402744	LM.40-SST M12x80-TR	16000	190
401746	LM.40 M12x100-TR	40	M12	127.5	100	27.5	17	33000	205	402746	LM.40-SST M12x100-TR	16000	211
401747	LM.50 M8x50-TR	50	M8	79.5	50	29.5	15	14000	172	402747	LM.50-SST M8x50-TR	7000	172
401748	LM.50 M8x63-TR	50	M8	92.5	63	29.5	15	14000	180	402748	LM.50-SST M8x63-TR	7000	180
401749	LM.50 M8x80-TR	50	M8	109.5	80	29.5	15	14000	187	402749	LM.50-SST M8x80-TR	7000	187
401750	LM.50 M10x50-TR	50	M10	79.5	50	29.5	15	23000	207	402750	LM.50-SST M10x50-TR	11000	207
401751	LM.50 M10x63-TR	50	M10	92.5	63	29.5	15	23000	215	402751	LM.50-SST M10x63-TR	11000	215
401752	LM.50 M10x80-TR	50	M10	109.5	80	29.5	15	23000	222	402752	LM.50-SST M10x80-TR	11000	222
401753	LM.50 M12x63-TR	50	M12	92.5	63	29.5	17	33000	260	402753	LM.50-SST M12x63-TR	16000	268
401754	LM.50 M12x80-TR	50	M12	109.5	80	29.5	17	33000	255	402754	LM.50-SST M12x80-TR	16000	255
401756	LM.50 M12x100-TR	50	M12	129.5	100	29.5	17	33000	285	402756	LM.50-SST M12x100-TR	16000	295
401758	LM.50 M16x63-TR	50	M16	92.5	63	29.5	17	40000	286	402757	LM.50-SST M16x63-TR	30000	286
401759	LM.50 M16x80-TR	50	M16	109.5	80	29.5	17	40000	298	402758	LM.50-SST M16x80-TR	30000	298
401757	LM.50 M16x100-TR	50	M16	129.5	100	29.5	17	40000	311	402759	LM.50-SST M16x100-TR	30000	311
401787	LM.60 M10x50-TR	60	M10	87.5	50	37.5	17	23000	367	402767	LM.60-SST M10x50-TR	11000	367
401788	LM.60 M10x63-TR	60	M10	100.5	63	37.5	17	23000	386	402768	LM.60-SST M10x63-TR	11000	386
401789	LM.60 M10x80-TR	60	M10	117.5	80	37.5	17	23000	405	402769	LM.60-SST M10x80-TR	11000	405
401760	LM.60 M12x63-TR	60	M12	100.5	63	37.5	17	33000	415	402760	LM.60-SST M12x63-TR	16000	440
401761	LM.60 M12x80-TR	60	M12	117.5	80	37.5	17	33000	450	402761	LM.60-SST M12x80-TR	16000	465
401762	LM.60 M12x100-TR	60	M12	137.5	100	37.5	17	33000	474	402762	LM.60-SST M12x100-TR	16000	500
401763	LM.60 M16x80-TR	60	M16	117.5	80	37.5	24	62000	505	402763	LM.60-SST M16x80-TR	30000	490
401765	LM.60 M16x100-TR	60	M16	137.5	100	37.5	24	62000	515	402765	LM.60-SST M16x100-TR	30000	515
401766	LM.60 M16x125-TR	60	M16	162.5	125	37.5	24	62000	550	402766	LM.60-SST M16x125-TR	30000	567
401771	LM.60 M20x98-TR	60	M20	135.5	98	37.5	24	95000	550	402771	LM.60-SST M20x98-TR	45000	550
401773	LM.60 M20x138-TR	60	M20	175.5	138	37.5	24	95000	580	402773	LM.60-SST M20x138-TR	45000	580
401776	LM.60 M20x158-TR	60	M20	195.5	158	37.5	24	95000	610	402776	LM.60-SST M20x158-TR	45000	610
401781	LM.60 M24x98-TR	60	M24	135.5	98	37.5	24	95000	610	402781	LM.60-SST M24x98-TR	30000	610
401783	LM.60 M24x138-TR	60	M24	175.5	138	37.5	24	95000	630	402783	LM.60-SST M24x138-TR	30000	630
401786	LM.60 M24x158-TR	60	M24	195.5	158	37.5	24	95000	650	402786	LM.60-SST M24x158-TR	30000	650

