

**USB Host Charger Controller supporting BC1.2, YD/T-1591, & Non-standard Protocols**

**Features**

- Manages communication to allow charging to occur
- Provides multiple modes of charging to ensure all of the following specs can be met:
  - DCP, CDP, and SDP per BC1.0, 1.1, 1.2 spec
  - DCP per YD/T-1591 spec
  - Samsung fast charging
  - Sony Ericsson fast charging
  - Apple fast charging 1A and 2A
  - Amazon Kindle Fire
- Automatic USB Device Identification Circuit (used to determine charging mode required)
- Single Power Supply, 5V ±5%
- -40°C to +85°C Operating Temperature Range
- Integrated ESD protection up to +/- 4kV contact on pins 2 and 3 per IEC61000-4-2 spec
- Detects and differentiates between High-Speed devices and mouse/keyboard (USB Low/Full Speed device) when in Auto dedicated charging mode
- Anti-loop protection for hard disk drive (HDD)
- Packaging (Pb-free & Green):
  - 8-Contact TDFN, ZA (2.0mm x 2.0mm x 0.75mm)

**Description**

Notebook PCs are used around the world to charge battery-powered handheld devices such as cell phones, tablets and MP3/MP4 players. Hand-held devices require communication with the notebook PC before they start to draw current. This ensures that the handheld device will obtain sufficient current when it wants to charge. The challenge is that notebook PC's do not provide acknowledge signal to the handheld device when the notebook is in "Sleep" mode.

The PI5USB1458(/A) solves this issue by setting the D+/D- pins in the notebook PC to the required signal levels during "sleep" mode. When the handheld device sees these required signal levels, it will then start to draw the current required to charge itself.

Cell phones within today's market use different communication schemes, so the switch will need to configure itself in different modes. PI5USB1458 (/A) can alternate between modes automatically, once device type is correctly detected.

D+, D- are protected with Diodes' ESD protection circuits supporting ESD damage as high as +/-4kV contact per IEC61000-4-2 specification.

**Block Diagram**

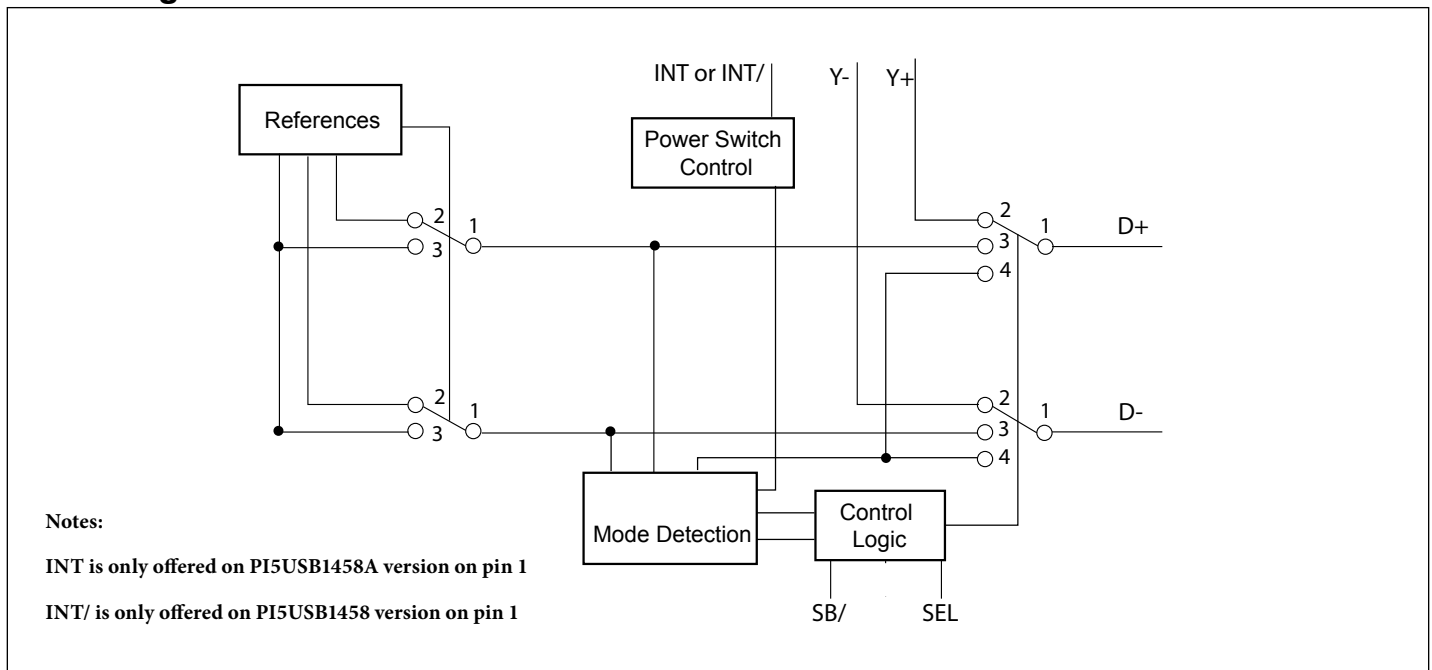

### Pin Configuration (Top View)

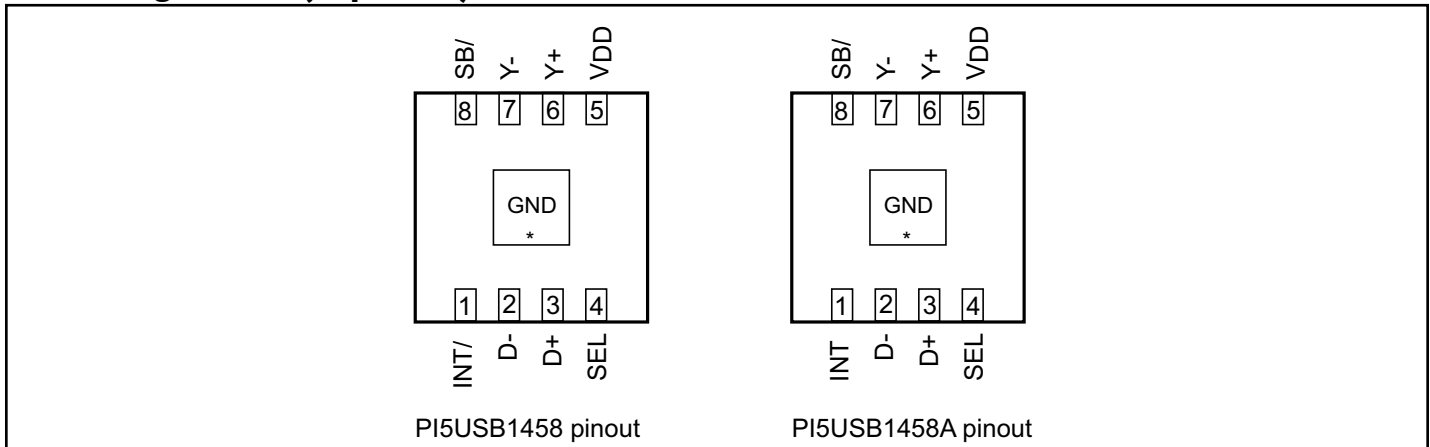

### Pin Description

P5USB1458	PI5USB1458A	Pin Name	I/O Type	Description
1	N/A	INT/	O	p-mosfet open source output. When SB/ observes a logic change (from H to L or from L to H). INT/ is high for ~ 2.4 seconds, otherwise INT/ is hi-z. External pull-down is required.
N/A	1	INT	O	n-mosfet open drain output. When SB/ observes a logic change (from H to L or from L to H). INT is LOW for ~ 2.4 seconds, otherwise, INT is hi-z. External pull-up is required.
2	2	D-	I/O	USB Connector, D- connection
3	3	D+	I/O	USB Connector, D+ connection
4	4	SEL	I	Input control logic (See truth table), 100kΩ pull down
5	5	V <sub>DD</sub>	Power	5V power supply
6	6	Y+	I/O	Host USB transceiver (if existent) D+ connection
7	7	Y-	I/O	Host USB transceiver (if existent) D- connection
8	8	SB/	I	Control input to switch between S0 charging or sleep and charge
*	*	GND	Ground	Exposed Pad. Connect to ground.

### PI5USB1458 and PI5USB1458A Truth Table

SB/	SEL	Feature	pin 1 role (INT or INT/)
0	0 or 1	Auto dedicated charger with mouse/keyboard pass through	INT or INT/
1	0	S0 charging with SDP only	INT or INT/
1	1	S0 charging with CDP or SDP only (depending on external device)	INT or INT/

## Detailed Feature Description

### Auto Dedicated Charging Mode enabled

When the PI5USB1458 (/A) is configured into auto mode with Auto dedicated charging mode enabled (see truth table to understand how to configure into auto mode), the charger controller will manage all communication with external devices to enable charging to occur. First, Diodes' IC will use load sensing techniques to detect when a device has been plugged in.

Once a device is properly detected, the Diodes IC will automatically switch to the appropriate charging mode required for the specific external USB device that was detected.

### Mouse/Keyboard pass through mode Explanation

Today's systems are enabled to wake up from S3 mode if a pre-enumerated mouse/keyboard has activity (movement or key-pressed). In order for the system to continue supporting this feature, the USB host controller must be able to communicate with the external device in S3 mode. Therefore, if a mouse/keyboard is detected (via the USB low-speed/ full-speed pass through feature), Diodes' PI5USB1458 family will enable the communication between device and controller. Our device will automatically pass the signals through with minimal degradation.

Once SB/ signal goes from high to low (indicating system has changed from S0 to S3), Diodes' device will detect the external USB device. If the device is detected as a mouse or keyboard (determined by looking at USB data-rate) we will ensure the connection between the USB device and USB host remains in place.

### Anti-Loop protection for HDD

This circuit prevents hard disk drive from turning on and off continuously.

### Auto Dedicated Charger mode description

During Diodes' Auto dedicated charger mode, we automatically detect and enable DCP charging modes for all popular USB devices on the market.

DCP stands for Dedicated Charging Port. Per the Battery Charging Spec, DCP is described as a host charging mode whereas only charging is allowed. Data transfer through USB, during DCP mode is not allowed. Per the Battery Charging Spec, the host charger must short D+ to D-, and in turn the USB device will draw up to 1.5A.

Since the release of the Battery Charging Spec, certain mobile phone and tablet OEMs have released products with unique dedicated charging modes. When Diodes' Auto dedicated charger mode is enabled, we can automatically switch between dedicated charging modes per the Battery charging spec or other dedicated charging modes supported by specific OEMs.

### CDP mode description

Charging Downstream Port (CDP) is the communication protocol found in host chargers capable of supplying up to 1.5A current to charge external USB devices. The communication scheme is defined clearly in the USB Battery Charging Spec 1.2. A CDP link can allow USB data to be transferred between the host charger and the external device as well as allow charging to occur. The actual current draw is managed by the external device while the CDP only limits the max current draw to 1.5A. Diodes is able to fully support this communication, which includes both a primary and secondary detection procedure.

### BC 1.2 Suspend Charging (DCP)

The suspend-charge (DCP) mode defined in BC 1.2 is a manual-DCP-mode, is not exactly the same as the auto suspend-charge mode in PI5USB1458. In order to offer an accurate BC 1.2 suspend-charge (DCP) mode apply: "SB/" to 1 and "SEL" pin with 1.25V, Power-off, then after re-power-on PI5USB1458/A.

**Maximum Ratings** (Above which the useful life may be impaired. For user guidelines, not tested)

All Inputs and Outputs .....	-0.5V to $V_{DD} + 0.5V$
Storage temperature.....	-65 to +150°C
Ambient Operating Temperature.....	-40 to +85°C
Supply Voltage to Ground Potential ( $V_{DD}$ ) .....	+5.5V
Junction Temperature .....	+150°C
Soldering Temperature (Max of 10 seconds) .....	+260°C

**Note:**

Stresses greater than those listed under MAXIMUM RATINGS may cause permanent damage to the device. This is a stress rating only and functional operation of the device at these or any other conditions above those indicated in the operational sections of this specification is not implied. Exposure to absolute maximum rating conditions for extended periods may affect reliability.

**Electrical Parameters/Characteristics** Recommended Operation Conditions

Parameter	Min.	Typ.	Max.	Unit
Ambient Operating Temperature	-40		+85	°C
$V_{DD}$ Power Supply Voltage (measured in respect to GND)	+4.75		+5.25	V

**DC Electrical Characteristics** ( $V_{DD} = 5.0V \pm 5\%$ , Ambient Temperature -40 to +85°C)

Symbol	Parameter	Conditions	Min.	Typ.	Max.	Unit	
$V_{DD}$	Operating Voltage		4.75		5.25	V	
$I_{DD}$	Supply Current	$V_{DD} = 5.25V$	SB/ = Low, SEL = Low		280	400	$\mu A$
			SB/ = Low, SEL = High		240	380	
			SB/ = High, SEL = Low		180	300	
			SB/ = High, SEL = High		160	250	
$V_{IH\_SB}$	Input High Voltage for SB/	$V_{DD} = 5V$	1.4			V	
$V_{IL\_SB}$	Input Low Voltage for SB/	$V_{DD} = 5V$			0.4		
$V_{IH\_SEL}$	Input High Voltage for SEL	$V_{DD} = 5V$	2.6				
$V_{IL\_SEL}$	Input Low Voltage for SEL	$V_{DD} = 5V$			0.6		
$I_{IH\_SB}$	Input High Current for SB/	$V_{DD} = 5.25V, V_{SB/} = 5.25V$	-1		+1	$\mu A$	
$I_{IL\_SB}$	Input Low Current for SB/	$V_{DD} = 5.25V, V_{SB/} = 0V$	-1		+1		
$I_{IH\_SEL}$	Input High Current for SEL	$V_{DD} = 5.25V, V_{SEL} = 5.25V$	-1		+1		
$I_{IL\_SEL}$	Input Low Current for SEL	$V_{DD} = 5.25V, V_{SEL} = 0V$	-1		+1		
$V_{OH}$ for INT/	Output high voltage for INT/	PI5USB1458ZAE only, $I_{OH} = -4mA$	4.0			V	
$V_{OL}$ for INT	Output low voltage for INT	PI5USB1458AZAE only, $I_{OL} = 4mA$			0.25	V	

**DC Electrical Characteristics** ( $V_{DD} = 5.0V \pm 5\%$ , Ambient Temperature  $-40$  to  $+85^{\circ}C$ )

Symbol	Parameter	Conditions	Min.	Typ.	Max.	Unit
$R_{ON}$	Switch On-Resistance for USB 2.0 HS signal (From $D_{\pm}$ to $Y_{\pm}$ )	$V_{DD} = 4.75V$ , $-0.4V < V_{INPUT} < +0.4V$ , $I_{INPUT} = +30mA$ , $SB/ = High$		3	5	$\Omega$
$R_{ON}$	Switch On-Resistance for USB 2.0 FS signal (From $D_{\pm}$ to $Y_{\pm}$ )	$V_{DD} = 5.0V$ , $0V < V_{INPUT} < 3.3V$ $I_{INPUT} = -15mA$ , $SB/ = High$			10	
$I_{OZ}$	I/O leakage on signal pins ( $D_{\pm}$ , $Y_{\pm}$ ) current when port is off	$V_{DD} = 5.25V$ , $V_{INPUT}$ from $0V$ to $3.6V$	-5		+5	$\mu A$
$I_{OFF}$	Signal leakage on signal pins ( $D_{\pm}$ , $Y_{\pm}$ ) when chip is off	$V_{DD} = 0V$ , $V_{INPUT}$ from $0V$ to $5.25V$	-5		+5	$\mu A$

**Capacitance** (For typical spec  $T_A = 25^{\circ}C$ , for max spec  $T_A = -40$  to  $+85^{\circ}C$ ,  $f = 1MHz$ )

Parameter	Description	Test Condition	Typ.	Max.	Unit
$C_{IN}$	Control Logic Capacitance		2.7	4	$pF$
$C_{OFF}$ - USB path only	Switch Capacitance at $D_{\pm}$ or $Y_{\pm}$ when switch is OFF	$SB/ = low$	3.1	3.5	
$C_{ON}$ - USB path only	Switch Capacitance between $D+/-$ to $Y+/-$ when switch is ON	$SB/ = high$	8	10	

**Dynamic Electrical Characteristics Over the Operating Range**

Parameter	Description	Test Condition	Min.	Typ.	Max.	Units
XTALK	Crosstalk	$R_L = 50\Omega$ , freq = 240MHz (Figure 2)		-30		dB
OIRR	Off-Isolation	$R_L = 50\Omega$ , freq = 240MHz (Figure 2)		-30		
-3dB BW	-3dB Bandwidth (along $D+/-$ path)	$R_L = 50\Omega$		1,350		MHz
-0.5dB BW	-0.5dB Bandwidth (along $D+/-$ path)	$R_L = 50\Omega$		350		
$IN_{LOSS}$	Insertion loss (along $D+/-$ path)	freq = 240MHz (Figure 2)		-0.60		dB

**PI5USB1458/PI5USB1458A**

**Internal Resistors** ( $V_{DD} = 5.0V \pm 5\%$ , Ambient Temperature  $-40$  to  $+85^{\circ}C$ )

Symbol	Parameter	Test Condition	Min.	Typ.	Max.	Unit
$R_{PD}$	D+/D- Short Pull-down		350	500	700	$k\Omega$
$R_{TRP}$	RP1/RP2 Ratio		1.485	1.5	1.515	Ratio
$R_{RP}$	RP1 + RP2 Resistance		93.75	125.0	156.25	$k\Omega$
$R_{TRM}$	RM1/RM2 Ratio		0.8544	0.863	0.872	Ratio
$R_{PM}$	RM1 + RM2 Resistance		69.75	93.0	115.18	$k\Omega$

**CDP Mode**

Symbol	Parameter	Test Condition	Min.	Max.	Units
$V_{D-\_SRC}$	Voltage source on D- for CDP detect	$V_{D-} = 0.6V$	0.5	0.7	V
$V_{D+\_SINK}$	D+_IN sink current	$0.4V \leq V_{D-} < 0.8V$	50	150	$\mu A$

Parameter	Description	Test Condition	Min .	Typ.	Max .	Units
$T_{pd}$	Propagation delay	Output has no load		0.3		ns
Intra-Pair Skew	Output skew, bit to bit (Between + and - of same pair)	Output has no load		10		ps
$T_{ON}$	Turn on time for USB path	$C_L = 35pF, R_L = 300\Omega$ (Figure 1)			0.5	$\mu s$
$T_{OFF}$	Turn off time for USB path	$C_L = 35pF, R_L = 300\Omega$ (Figure 1)			0.25	

**Application Recommendations & Reference Design Diagram**

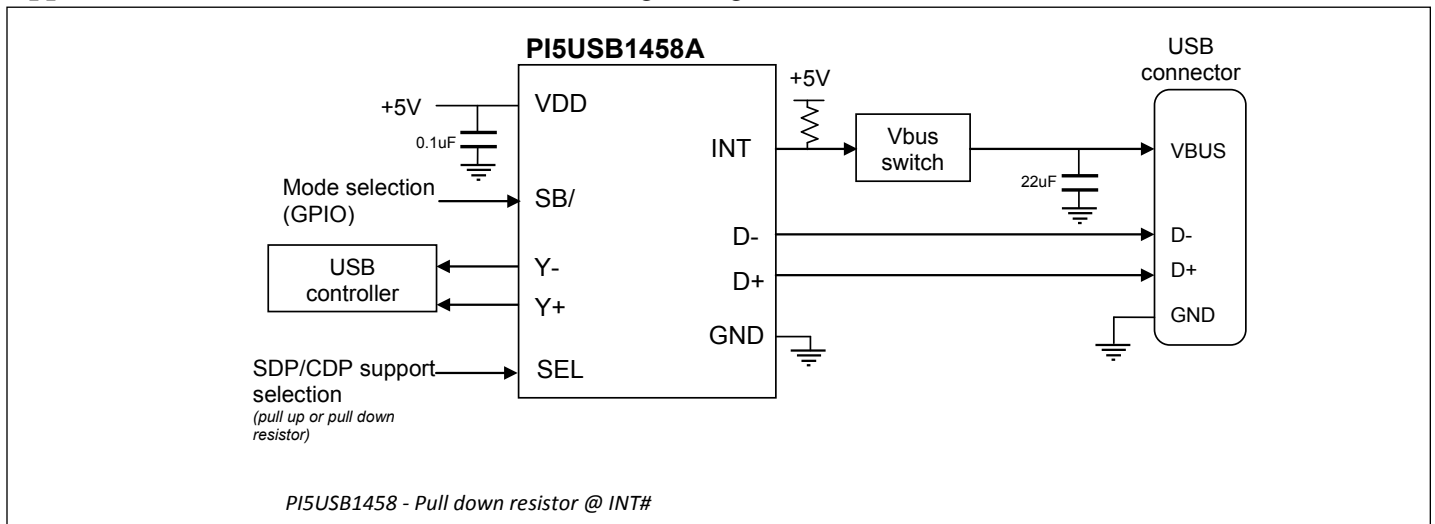

**Figure 1: Test Circuit for Electrical Characteristics**

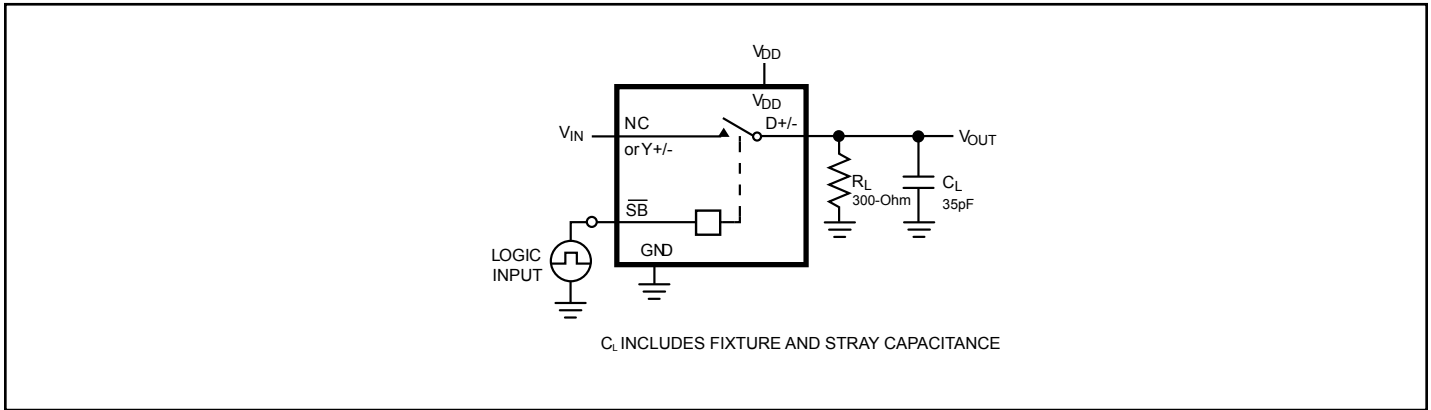

**Notes:**

1.  $C_L$  = Load capacitance: includes jig and probe capacitance.
2.  $R_T$  = Termination resistance: should be equal to  $Z_{OUT}$  of the Pulse Generator
3. All input impulses are supplied by generators having the following characteristics:  $PRR \leq \text{MHz}$ ,  $Z_o = 50\Omega$ ,  $t_R \leq 2.5\text{ns}$ ,  $t_F \leq 2.5\text{ns}$ .

**Figure 2: Test Circuit for Dynamic Electrical Characteristics**

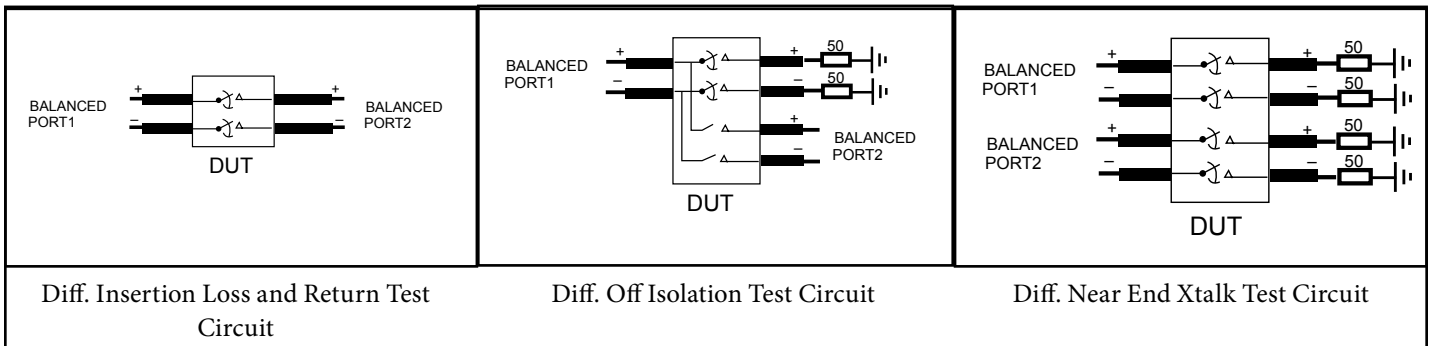

**Figure 3: CDP - HS Eye Diagram**

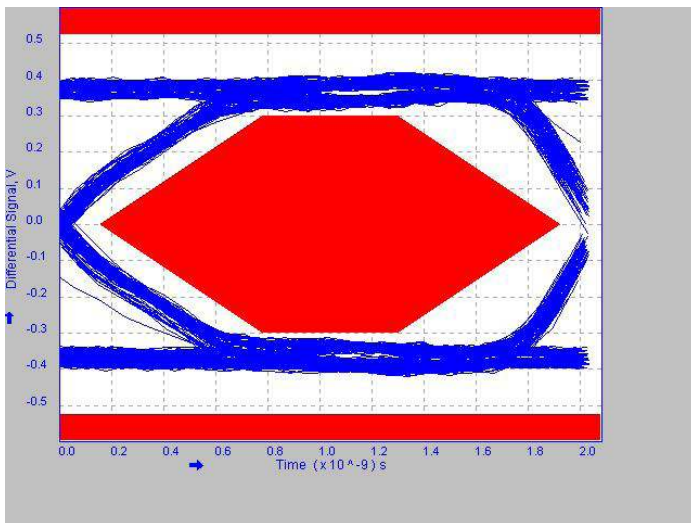

**Figure 4: SDP - HS Eye Diagram**

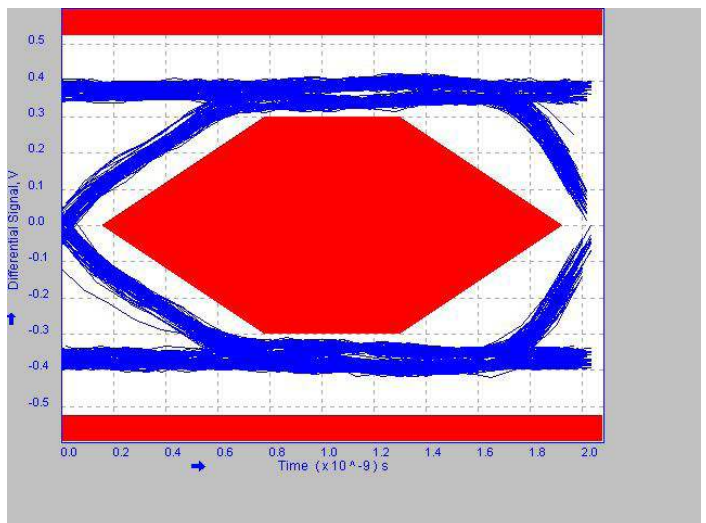

**Packaging Mechanical: 8-Pin TDFN (ZA)**

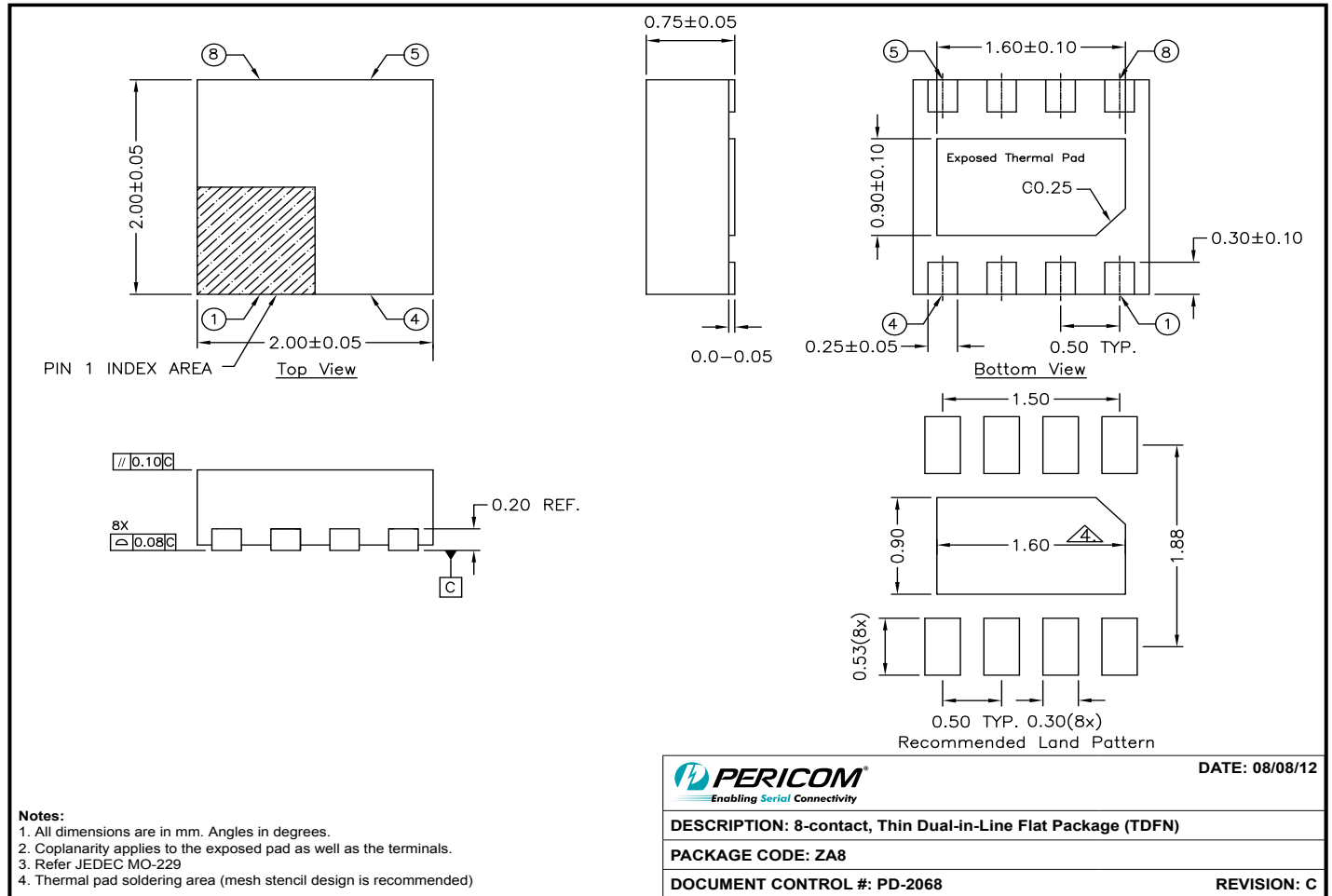

13-0126

Note: For latest package info, please check: <http://www.pericom.com/support/packaging/packaging-mechanicals-and-thermal-characteristics/>

**Ordering Information**

Ordering Code	Package Code	Package Description
PI5USB1458ZAE	ZA	8-contact, Thin Dual-in-Line Flat Package (TDFN)
PI5USB1458ZAEX	ZA	8-contact, Thin Dual-in-Line Flat Package (TDFN), Tape & Reel
PI5USB1458AZAE	ZA	8-contact, Thin Dual-in-Line Flat Package (TDFN)
PI5USB1458AZAEX	ZA	8-contact, Thin Dual-in-Line Flat Package (TDFN), Tape & Reel

**Notes:**

- Thermal characteristics can be found on the company web site at [www.pericom.com/packaging/](http://www.pericom.com/packaging/)
- E = Pb-free and Green
- X suffix = Tape/Reel



#### IMPORTANT NOTICE

DIODES INCORPORATED MAKES NO WARRANTY OF ANY KIND, EXPRESS OR IMPLIED, WITH REGARDS TO THIS DOCUMENT, INCLUDING, BUT NOT LIMITED TO, THE IMPLIED WARRANTIES OF MERCHANTABILITY AND FITNESS FOR A PARTICULAR PURPOSE (AND THEIR EQUIVALENTS UNDER THE LAWS OF ANY JURISDICTION).

Diodes Incorporated and its subsidiaries reserve the right to make modifications, enhancements, improvements, corrections or other changes without further notice to this document and any product described herein. Diodes Incorporated does not assume any liability arising out of the application or use of this document or any product described herein; neither does Diodes Incorporated convey any license under its patent or trademark rights, nor the rights of others. Any Customer or user of this document or products described herein in such applications shall assume all risks of such use and will agree to hold Diodes Incorporated and all the companies whose products are represented on Diodes Incorporated website, harmless against all damages.

Diodes Incorporated does not warrant or accept any liability whatsoever in respect of any products purchased through unauthorized sales channel.

Should Customers purchase or use Diodes Incorporated products for any unintended or unauthorized application, Customers shall indemnify and hold Diodes Incorporated and its representatives harmless against all claims, damages, expenses, and attorney fees arising out of, directly or indirectly, any claim of personal injury or death associated with such unintended or unauthorized application.

Products described herein may be covered by one or more United States, international or foreign patents pending. Product names and markings noted herein may also be covered by one or more United States, international or foreign trademarks.

This document is written in English but may be translated into multiple languages for reference. Only the English version of this document is the final and definitive format released by Diodes Incorporated.

#### LIFE SUPPORT

Diodes Incorporated products are specifically not authorized for use as critical components in life support devices or systems without the express written approval of the Chief Executive Officer of Diodes Incorporated. As used herein:

A. Life support devices or systems are devices or systems which:

1. are intended to implant into the body, or

2. support or sustain life and whose failure to perform when properly used in accordance with instructions for use provided in the labeling can be reasonably expected to result in significant injury to the user.

B. A critical component is any component in a life support device or system whose failure to perform can be reasonably expected to cause the failure of the life support device or to affect its safety or effectiveness.

Customers represent that they have all necessary expertise in the safety and regulatory ramifications of their life support devices or systems, and acknowledge and agree that they are solely responsible for all legal, regulatory and safety-related requirements concerning their products and any use of Diodes Incorporated products in such safety-critical, life support devices or systems, notwithstanding any devices- or systems-related information or support that may be provided by Diodes Incorporated. Further, Customers must fully indemnify Diodes Incorporated and its representatives against any damages arising out of the use of Diodes Incorporated products in such safety-critical, life support devices or systems.

Copyright © 2016, Diodes Incorporated

[www.diodes.com](http://www.diodes.com)