

Self-Calibrating TPOS GMR Camshaft Speed Sensor IC

FEATURES AND BENEFITS

- **GMR technology** integrates high sensitivity MR (magnetoresistive) sensor elements and high precision BiCMOS circuits on a single silicon integrated circuit, offering high accuracy, low magnetic field operation
- **Allegro SM package** with integrated EMC components eliminates need for external EMI protection
- **True target state recognition** at device power-on (TPOS)
- **EEPROM programming** for performance optimization, temperature compensation, and production traceability
- **Flexible orientation:** Able to be mounted at any angle with correct configuration
- **Stray Field Immunity:** Resists aggressor stray fields found in hybrid vehicle environments
- **Backward compatibility** with Allegro's Hall-effect solutions performance
- **Target Profile Diagnostics**

PACKAGE:



3-pin SIP (suffix SM)

Not to scale

DESCRIPTION

The ATS16351 is a True Power-On State (TPOS) camshaft sensor incorporating a back-biasing magnet, advanced fully synchronous digital IC, and EMC protection circuit all in a single sensing solution.

The ATS16351 incorporates a GMR bridge with an optimized custom magnetic circuit that switches in response to magnetic signals induced by a ferromagnetic target. The IC contains a sophisticated digital circuit designed to match the temperature behavior of the sensor IC with the integrated magnet. Signal processing is used to provide zero-speed performance independent of air gap and is designed for the typical operating conditions found in automotive camshaft sensing applications. The resulting output of the device is a digital representation of the ferromagnetic target profile.

The Auto-TPOS feature of the ATS16351 enables the sensor IC to learn the installation air gap inside of the engine and to autonomously reprogram into memory the optimal threshold for power-on accuracy.

A number of factory-programmable options allow for performance optimization to meet specific application requirements.

The ATS16351PSM is available in a 3-pin package (SM) that is lead (Pb) free, with 100% NiPdAu plating.

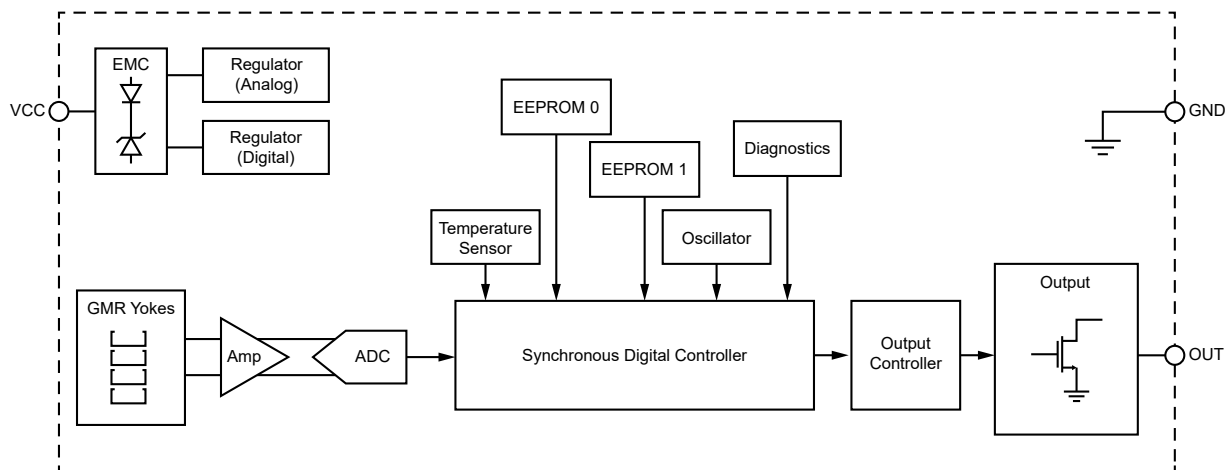

Figure 1: Functional Block Diagram

PROGRAMMABLE OPTIONS

Name	Available Selections*			
Output Polarity	Low opposite target tooth / high opposite target valley (L Option)		High opposite target tooth / low opposite target valley (H Option)	
Switch Point Variation	C82C85D30D30 (S01 Option)		C83C83D7D7 (S03 Option)	
	S(00-99): C(25-102) C(25-102) D(0-30)D(0-30) indicating threshold level and dynamic slope. 1st and 2nd C(25-102) indicates rising and falling threshold level from C25 to C102 that corresponds to ~20% to ~80% switch point threshold level with a step of ~0.78%. 1st and 2nd D(0-30) indicates rising and falling threshold dynamic slope from D1 to D30 that corresponds to ~0.225 to ~0.975%/mV with a step of ~0.025%/mV.			
Teeth Memory	Number of teeth (memory count); programmable from 1 to 13 (Nx Option)			
Output Fall Time	Slow: typical 5 μ s (S Option)	Average: typical 2.5 μ s (A Option)	Fast: typical 1.2 μ s (F Option)	
Running Mode Hidden Hysteresis	10% (S Option)	15% (R Option)	20% (B Option)	30% (V Option)
Delay Time (tradeoff of jitter vs. speed effect)	No extra delay time (smallest speed effect): 16.7 μ s (T1 Option)	Small extra delay: 19.7 μ s (T2 Option)	Medium extra delay: 20.3 μ s (T3 Option)	Large extra delay (best jitter performance): 40 μ s (T4 Option)
Target Profiling Diagnostics	Magnetic profile available on output (-D option)		Magnetic profile unavailable on output ([blank] option)	

*Not all combinations of programmable options are available pre-programmed from Allegro. Contact Allegro for details.

SELECTION GUIDE

Part Number*	Package	Packing
ATS16351PSMGTN-LS01N12BFRT1-D	3-pin SIP with NiPdAu leadframe plating	Tape and reel, 800 pieces per 13-inch reel
ATS16351PSMGTN-LS03N12BFRT1-D		

*Not all combinations of programmable options are available pre-programmed from Allegro. Contact Allegro for details.



ATS16351 P SMD TN - □ S □ □ N □ □ □ T □ □

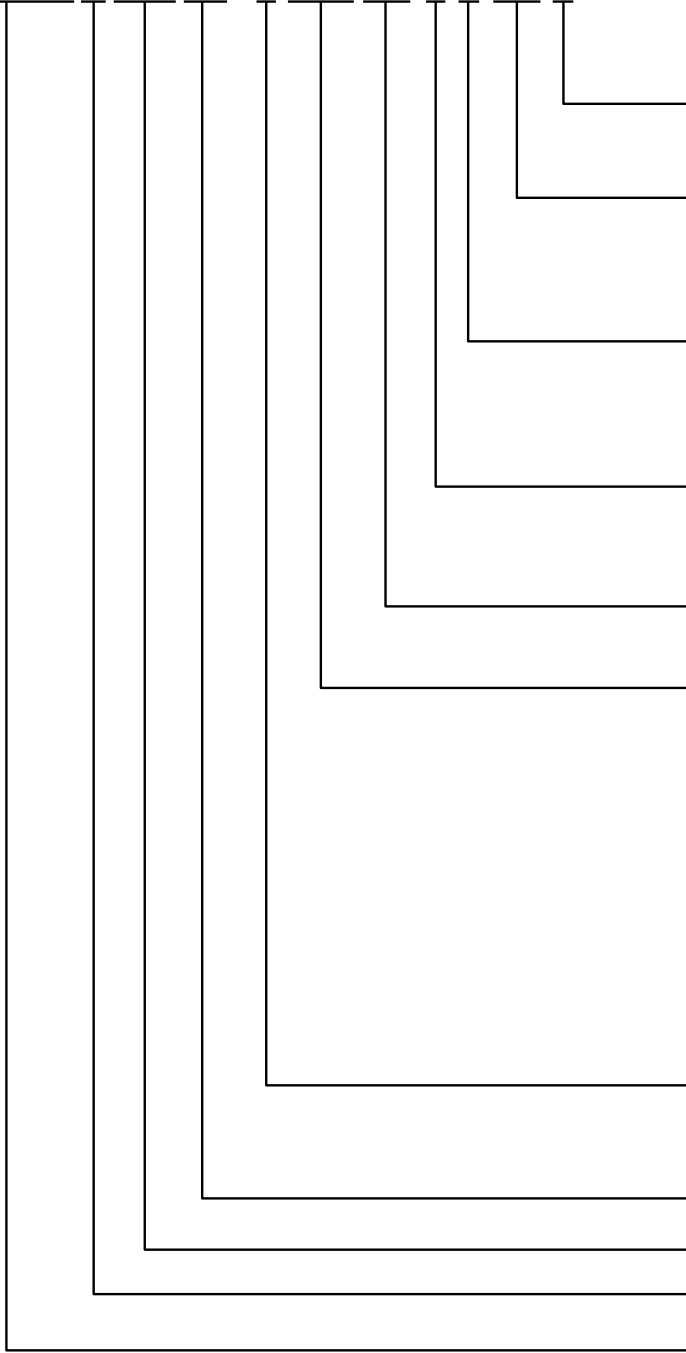

Target profile diagnostic feature:

-D: Feature enabled
[blank]: Feature disabled

Delay time (typical):

T1: 16.7 μ s
T2: 19.7 μ s
T3: 20.3 μ s
T4: 40 μ s

Hidden hysteresis (typical):

S: 10%
R: 15%
B: 20%
V: 30%

Typical Output fall time:

S: 5 μ s
A: 2.5 μ s
F: 1.2 μ s

Number of teeth memory

N(1-13): Teeth (memory count) from N1 to N13

Switch Point variation

S01 : C82C85D30D30
S03 : C83C83D7D7

Options:

S(00-99): C(25-102) C(25-102) D(0-30)D(0-30)
indicating threshold level and dynamic slope.
1st and 2nd C(25-102) indicates rising and falling
threshold level from C25 to C102 that corresponds
to ~20% to ~80% switching point threshold level
with a step of ~0.78%.
1st and 2nd D(0-30) indicates rising and falling
threshold dynamic slope from D1 to D30 that
corresponds to ~ 0.225 to ~ 0.975%/mV with
a step of ~0.025 %/mV

Output polarity

L: Low over tooth
H: High over tooth

Packing type

Package

Temperature range

Allegro identifier and device type

ABSOLUTE MAXIMUM RATINGS

Characteristic	Symbol	Notes	Rating	Unit
Supply Voltage	V_{CC}		27	V
Reverse Supply Voltage	V_{RCC}		-18	V
Output Voltage	V_{PU}		27	V
Reverse Output Voltage	V_{ROUT}	$R_{PU} \geq 1000 \Omega$	-0.5	V
Output Current	I_{OUT}	Internal current limiting is intended to protect the device from output short circuits but is not intended for continuous operation.	25	mA
Reverse Output Current	I_{ROUT}	$V_{OUT} > -0.5 \text{ V}$, $T_A = 25^\circ\text{C}$	-50	mA
Operating Ambient Temperature	T_A	Range P	-40 to 160	$^\circ\text{C}$
Maximum Junction Temperature	$T_{J(max)}$		175	$^\circ\text{C}$
Storage Temperature	T_{stg}		-65 to 170	$^\circ\text{C}$
Applied Magnetic Flux Density	B	In any direction	150	G

INTERNAL DISCRETE COMPONENT RATINGS

Symbol	Characteristic	Rating	Unit
C_{SUPPLY}	Nominal Capacitance	220	nF
C_{OUT}	Nominal Capacitance	2.2	nF
R_{SUPPLY}	Nominal Resistance	33	Ω
R_{OUT}	Nominal Resistance	20	Ω

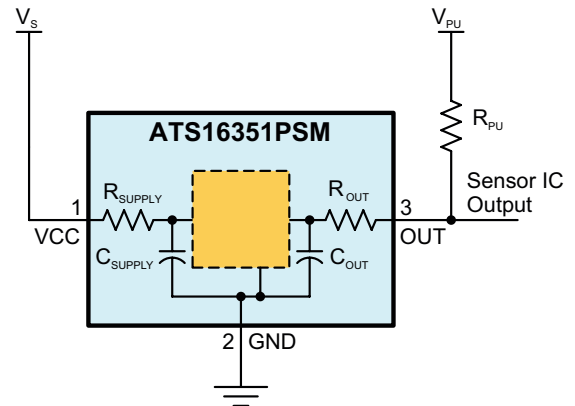

Figure 2: Typical Application Circuit

PINOUT LIST

Number	Name	Function
1	VCC	Supply voltage
2	GND	Ground
3	OUT	Device output

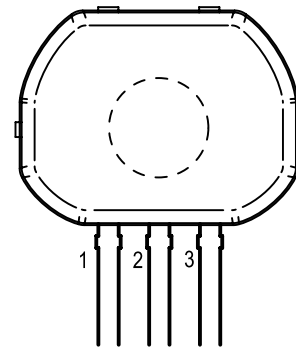

Figure 3: Pinout Diagram

OPERATING CHARACTERISTICS: Valid throughout full operating and temperature ranges; using Reference Target 8X, unless otherwise noted

Characteristics	Symbol	Test Conditions	Min.	Typ. [1]	Max.	Unit	
ELECTRICAL CHARACTERISTICS							
Supply Voltage	V_{CC}	Continuous operation, $T_J < T_{J(max)}$	3.6	–	24	V	
Supply Current	I_{CC}		5	7	10	mA	
Supply Zener Clamp Voltage	$V_{Zsupply}$	$I_{CC} = I_{CC(MAX)} + 3 \text{ mA}$	27	–	–	V	
Reverse Supply Zener Clamp Voltage	$V_{RZsupply}$	$I_{CC} = -3 \text{ mA}$, $T_A = 25^\circ\text{C}$	–	–	-18	V	
OUTPUT STAGE CHARACTERISTICS							
Output LOW Voltage	$V_{OUT(SAT)}$	$I_{OUT} = 5 \text{ mA}$	–	–	300	mV	
		$I_{OUT} = 15 \text{ mA}$	–	–	800	mV	
Output Zener Clamp Voltage	$V_{Zoutput}$	$I_{OUT} = 3 \text{ mA}$, $T_A = 25^\circ\text{C}$	27	–	–	V	
Output Current Limit	$I_{OUT(LIM)}$	Output = LOW	30	–	80	mA	
Output Leakage Current	$I_{OUT(OFF)}$	$V_{OUT} = 24 \text{ V}$, Output = HIGH	–	–	10	μA	
Output Rise Time	t_r	Measured 10%-90% of V_{OUT} ; $R_{PU} = 1 \text{ k}\Omega$, $V_{PU} = 5 \text{ V}$	–	5	–	μs	
Output Fall Time	t_f	Measured 90%-10% of V_{OUT} ; $R_{PU} = 1 \text{ k}\Omega$, $V_{PU} = 5 \text{ V}$	A fall time option	2.5	5	9	μs
			M fall time option	1.5	2.5	3.5	μs
			F fall time option	0.5	1.2	2.5	μs
		Measured 90%-10% of V_{OUT} ; $R_{PU} = 1 \text{ k}\Omega$, $V_{PU} = 12 \text{ V}$	A fall time option	–	8	–	μs
			F fall time option	–	2	–	μs

[1] Typical values are at $T_A = 25^\circ\text{C}$ and $V_{CC} = 5 \text{ V}$. Performance may vary for individual units, within the specified maximum and minimum limits.

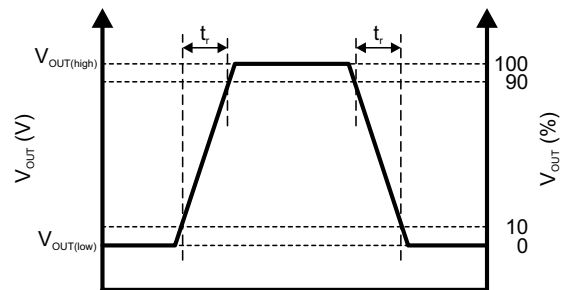

Figure 4: Output Rise Time and Output Fall Time

OPERATING CHARACTERISTICS (continued): Valid throughout full operating and temperature ranges; using Reference Target 8X, unless otherwise noted

Characteristics	Symbol	Note	Min.	Typ.	Max.	Unit	
PERFORMANCE CHARACTERISTICS							
Operational Air Gap Range	AG	TPOS guaranteed	1.5	–	4	mm	
Extended Operational Air Gap Range		Running mode switching, TPOS not guaranteed; Allegro reference target 8X	–	–	4.5	mm	
Signal Bandwidth	BW	Equivalent to –3 dB cutoff frequency	–	>8	–	kHz	
Phase Delay		Electrical falling edges; $R_{PU} = 1\text{ k}\Omega$, $V_{PU} = 5\text{ V}$; fall time to be added to this value	Option T1	–	16.7	–	μs
			Option T2	–	19.7	–	μs
			Option T3	–	20.3	–	μs
			Option T4	–	40	–	μs
POWER-ON CHARACTERISTICS							
Power-On Time [2]	t_{PO}	$f_{OP} < 100\text{ Hz}$, time from $V_{CC} > V_{CC(MIN)}$ to when IC enters calibration mode	–	–	1	ms	
TPOS Mode		Number of mechanical edges after power-on with output switching on TPOS threshold	M Option	–	N	$N + 3$ [3]	tooth
Learning Mode		Number of target teeth after TPOS Mode with reduced accuracy threshold-based output switching	M Option	–	–	1	tooth

[2] Power-On Time consists of the time from when V_{CC} rises above $V_{CC(MIN)}$ until a valid output state is realized.

[3] On some particular startup angle and air gaps, 1 to 3 extra teeth can be switching on TPOS before going on normal switching point.

OPERATING CHARACTERISTICS (continued): Valid throughout full operating and temperature ranges; using Reference Target 8X, unless otherwise noted

Characteristics	Symbol	Note	Min.	Typ.	Max.	Unit	
OPERATING MODE CHARACTERISTICS							
Output Polarity	V_{OUT}	Opposite target tooth, connected as in Figure 2	L option	Low		V	
			H option	High		V	
		Opposite target valley, connected as in Figure 2	L option	High		V	
			H option	Low		V	
Threshold Update Memory	N	Number of target teeth (peaks) stored in memory for threshold update algorithm	1	–	13	tooth	
Rising Threshold	B_{OP}	% of peak-to-peak, referenced to tooth signal. Programmable with a step of 0.78%. Defined as Cx in the programming options	20 [4]	–	80 [5]	%	
Falling Threshold	B_{RP}	% of peak-to-peak, referenced to tooth signal. Programmable with a step of 0.78%. Defined as Cx in the programming options	20 [4]	–	80 [5]	%	
Rising Threshold Slope	S_{OP}	Slope for rising Dynamic threshold feature. Programmable with a step of 0.025. Set to 0 to disable [6]. Defined as Dx in the programming options.	0.225	–	0.975	%/mV	
Falling Threshold Slope	S_{RP}	Slope for falling Dynamic threshold feature. Programmable with a step of 0.025. Set to 0 to disable [6]. Defined as Dx in the programming options.	0.225	–	0.975	%/mV	
Running Mode Hysteresis	$B_{HYS(int)}$	Programmable option % of peak-to-peak signal	H1 option	–	10	–	%
			H2 option	–	15	–	%
			H3 option	–	20	–	%
			H4 option	–	30	–	%
Maximum Allowable Signal Reduction	B_{reduce}	Reduction in magnetic signal amplitude between two consecutive peaks; all specifications within range.	–	–	$B_{OP} - 15\%$	%	
		Reduction in magnetic signal amplitude between two consecutive peaks; output switches, accuracy performance not guaranteed.	–	–	$B_{OP} - 5\%$	%	

[4] This is the minimum value it can be programmed if hidden hysteresis is set at 15%. If hidden hysteresis is not 15%, this limit becomes such that: $(B_{OP} \text{ or } B_{RP}) - \text{hidden hysteresis} > 5\%$.

[5] This is the maximum value it can be programmed if hidden hysteresis is set at 15%. If hidden hysteresis is not 15%, this limit becomes such that: $(B_{OP} \text{ or } B_{RP}) + \text{hidden hysteresis} < 95\%$.

[6] See Switching Point section for more details about dynamic threshold feature.

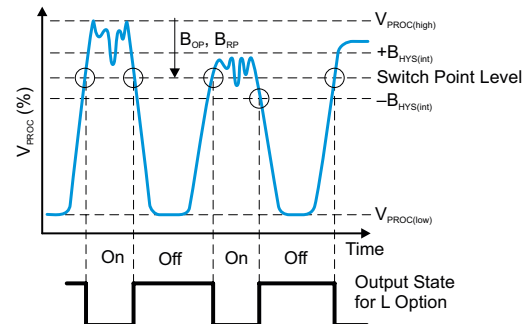
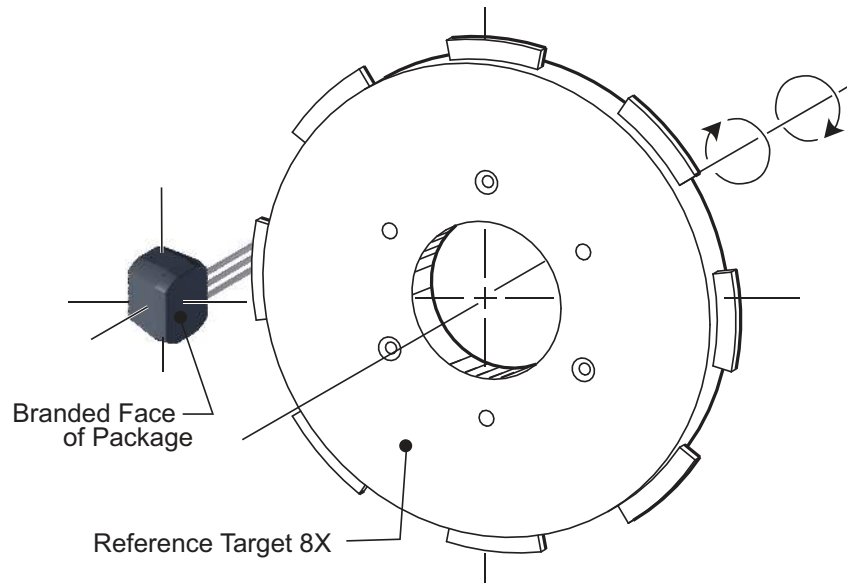

Figure 5: Switch Points with Internal Hysteresis

REFERENCE TARGET 8X

Characteristic	Symbol	Test Conditions	Typ.	Units	Symbol Key
Outside Diameter	D_o	Outside diameter of target	120	mm	
Face Width	F	Breadth of tooth, with respect to branded face	6	mm	
Circular Tooth Length	t	Length of tooth, with respect to branded face; measured at D_o	23.6	mm	
Circular Valley Length	t_v	Length of valley, with respect to branded face; measured at D_o	23.6	mm	
Tooth Whole Depth	h_t		5	mm	
Material		CRS 1018	-	-	



FUNCTIONAL DESCRIPTION

Sensing Technology

The ATS16351 contains a GMR bridge with an optimized custom magnetic circuit that switches in response to magnetic signals induced by a ferromagnetic target. The IC includes a self-calibrating GMR element that senses differences in magnetic field strength induced by ferromagnetic target teeth and valleys. The sensor generates a digital output signal that is representative of the target features, independent of the direction of target rotation or rotational orientation. The transducer and the electronics are integrated on the same silicon substrate by a proprietary BiCMOS process. Changes in temperature do not negatively affect this device due to the stable amplifier design and advanced digital temperature compensation. The IC also contains a voltage regulator that provides undervoltage lockout and supply noise rejection over the operating voltage range.

Target Profiling

The polarity of the output is selectable to be either low opposite target teeth (L option) or high opposite target teeth (H option). See Figure 6.

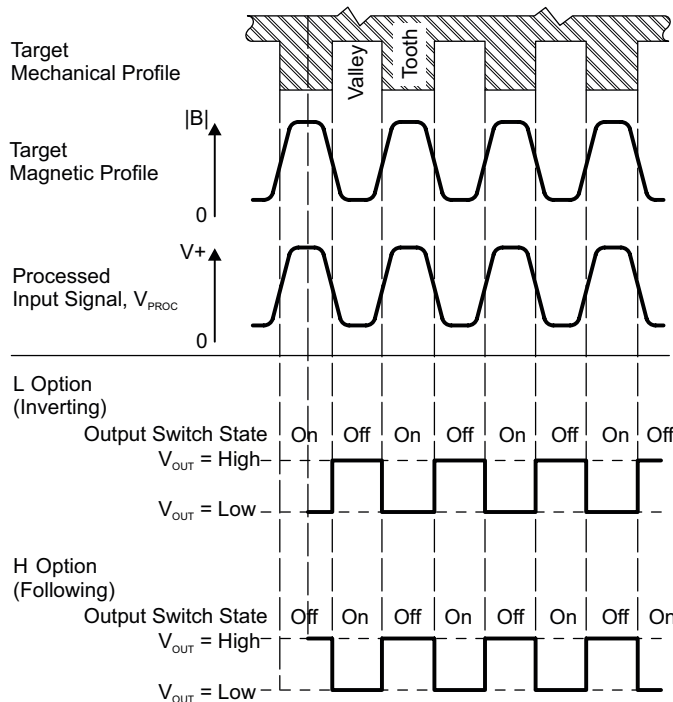

Figure 6: Output Polarity
(when connected as shown in Figure 2)

Threshold Update

The ATS16351 has two sets of programmable options that determine the threshold update used to establish running mode switching levels. The positive peak threshold update is set to n teeth, which is programmable between one and thirteen. The negative peak threshold update can either be set to continuous or bounded update. With single tooth update ($n = 1$), the switching threshold for a tooth is established based on the measured peak value of the previous tooth.

With single tooth update ($n = 1$), the switching threshold for a tooth is established based on the measured peak value of the previous tooth. This option can be used with targets having any number of teeth and is comparable to the continuous update mode used in many Allegro sensors.

When $n = 2$ through 13, the device uses memory-based update. Peak information from the last n teeth is stored in on-chip memory. Switching thresholds for the upcoming tooth are established based on the stored information from n teeth earlier. When n is matched to the number of teeth on the target, this allows for optimized switch points based on the same tooth from the previous revolution of the target. The programmable threshold update results in improved output switching accuracy on targets with runout and tooth-to-tooth variation (including narrow valleys).

With continuous update (A option), the switching threshold for a tooth is based on the measured valley value of the previous tooth. This option provides backwards compatibility equivalent to some older generations of Allegro TPOS camshaft cells.

With bounded update (B option), large tooth-to-tooth changes in the negative peak tracking are filtered out and not applied to switching threshold generation. This option provides improved output accuracy on camshaft targets with narrow valley widths.

Switch Points and Hysteresis

The running mode switch points in the ATS16351 are established dynamically as a percentage of the tracked peaks and valleys, as described in the Threshold Update section. There are two methods for deciding the switching point levels: classic fixed switching points and dynamic switching points. With the classic fixed switching points, the switching point levels can be programmed from 20% to 80% (when default hidden hysteresis is selected) with a step of 0.78%. If hidden hysteresis is not 15%, this limit becomes such that: $B_{OP}/B_{RP} + \text{hidden hysteresis} < 95\%$ and $B_{OP}/B_{RP} - \text{hidden hysteresis} < 5\%$. The slopes programming should

be set to 0 in order to have these fixed classic switching point levels.

The dynamic switching points are activated if a slope is selected. This mode determines the best switching point level per air gap for a given target and a given hard offset. To learn how to program this for a specific target, contact Allegro.

Internal hysteresis allows for high performance switching accuracy on both rising and falling edges while maintaining immunity to false switching on noise, vibration, backlash, or other transient events (see Figure 5). The default value of this hidden hysteresis is 15% (typical). Different values are possible, up to 10%, 15%, 20%, or 30%; contact Allegro for parts with higher hidden hysteresis. A higher hidden hysteresis allows for higher immunity to noise, vibration, or stray field. The downside of having a high hidden hysteresis is the limitation on signal reduction or tooth-to-tooth variation. Also having different values of hidden hysteresis limits the maximum and minimum values for the switching point levels as described on previous paragraphs.

Operating Modes

TPOS MODE

After power-on, the output state is determined by the level of the detected magnetic field relative to the fixed-gauss TPOS threshold, which is programmed at Allegro. The device remains in TPOS Mode for a number of edges that is dependent on the TPOS to Running mode transition option selected: rapid (R option), qualified (Q option), or memory based (M option).

With the rapid option, once the magnetic signal movement exceeds a fixed startup hysteresis value, the device immediately transitions to calibration mode and threshold-based switching. The R option provides the fastest transition to running mode thresholds, but in certain startup scenarios this can result in a large difference in output accuracy between the first edge and the same running mode edge.

With the qualified option, the device remains in TPOS mode for at least two edges before transitioning to running mode. The Q option provides the lowest worst-case output accuracy difference between the first edge and subsequent running mode edges.

With the memory-based option, the device remains in TPOS mode for n teeth, which is programmable between one and twelve, to guarantee it has correctly captured enough peaks to fill the running mode threshold memory. The M option provides the slowest transition to running mode thresholds but provides best runout capability.

SELF-CALIBRATING TPOS FEATURE

The self-calibrating TPOS feature of the ATS16351 enables the sensor IC to learn the installation air gap inside of the engine and autonomously reprogram into memory the optimal threshold for power-on accuracy. The first time the device is powered on, it will use the factory TPO value that is written in EEPROM. After the first cycles, if there is a significant difference between the factory TPO and the optimal TPO (middle point of the signal) value the device will self-write the optimal TPO value in EEPROM for all future use.

CALIBRATION MODE

In calibration mode, the ATS16351 uses threshold-based switching with continuous update. This ensures that all teeth and valleys are captured correctly but provides slightly reduced accuracy relative to running mode. The device stays in calibration mode long enough to guarantee it has correctly captured enough peaks to fill the running mode threshold memory. After calibration mode is complete, the device transitions to running mode.

RUNNING MODE

In running mode, the ATS16351 uses threshold-based switching with internal hysteresis as described in the previous Threshold Update, Switch Points, and Hysteresis sections. The threshold update is intended to optimize output switching accuracy when used with common camshaft targets, including cases with runout and narrow target valleys.

WATCHDOG

The ATS16351 has a peak detector continuously tracking the magnetic signal. If a sudden large signal change causes the sensor output to stop switching, but the peak detector continues to detect valid signal movement, the watchdog will be triggered. When it is triggered, the sensor performs a self-reset and returns to initial startup hysteresis mode to regain output switching.

Target Profile Diagnostics

Target Profile Diagnostics allows customers to characterize a gear target during manufacturing, and to detect any subtle gear tooth anomalies that may exist before an engine is installed into the vehicle, thus saving cost. It has the potential to reduce warranty returns, thus increasing customer satisfaction.

POWER DERATING

The device must operate below the rated maximum junction temperature of the device, $T_{J(max)}$. Under certain peak operating conditions, reliable operation may require power supply voltage derating and/or improved heat dissipation to ensure proper operation. This section presents a procedure for correlating factors that affect the operating junction temperature T_J . (Thermal data is also available on the Allegro MicroSystems website.)

The Package Thermal Resistance, $R_{\theta JA}$, is a figure of merit summarizing the ability of the package to dissipate heat from the junction (die), through all paths, to the ambient air. Its primary component is the Effective Thermal Conductivity, K , of the printed circuit board, including adjacent devices and traces. Radiation from the die through the device case, $R_{\theta JC}$, is a relatively small component of $R_{\theta JA}$. Ambient air temperature, T_A , and air motion are significant external factors, damped by overmolding.

The effect of varying power levels (Power Dissipation, P_D) can be estimated. The following formulas represent the fundamental relationships used to estimate T_J , at P_D .

$$P_D = V_{IN} \times I_{IN} \quad (1)$$

$$\Delta T = P_D \times R_{\theta JA} \quad (2)$$

$$T_J = T_A + \Delta T \quad (3)$$

For example, given common conditions such as: $T_A = 25^\circ\text{C}$, $V_{CC} = 12\text{ V}$, $I_{CC} = 7\text{ mA}$, and $R_{\theta JA} = 147^\circ\text{C/W}$, then:

$$P_D = V_{CC} \times I_{CC} = 12\text{ V} \times 7\text{ mA} = 84\text{ mW}$$

$$\Delta T = P_D \times R_{\theta JA} = 84\text{ mW} \times 147^\circ\text{C/W} = 12.3^\circ\text{C}$$

$$T_J = T_A + \Delta T = 25^\circ\text{C} + 12.3^\circ\text{C} = 37.3^\circ\text{C}$$

A worst-case estimate, $P_{D(max)}$, represents the maximum allowable power level ($V_{CC(max)}$, $I_{CC(max)}$), without exceeding $T_{J(max)}$, at a selected $R_{\theta JA}$ and T_A .

Example:

Reliability for V_{CC} at $T_A = 160^\circ\text{C}$, estimated values based on package SM, using single layer PCB.

Observe the worst-case ratings for the device, specifically:

$$R_{\theta JA} = 147^\circ\text{C/W}, T_{J(max)} = 175^\circ\text{C}, V_{CC(absmax)} = 24\text{ V}, \text{ and } I_{CC} = 10\text{ mA}.$$

Calculate the maximum allowable power level, $P_{D(max)}$. First, solve equation 3 for $\Delta T_{(max)}$, the specified $T_{J(max)}$, and T_A :

$$\Delta T_{(max)} = T_{J(max)} - T_A = 175^\circ\text{C} - 160^\circ\text{C} = 15^\circ\text{C}$$

This provides the allowable increase to T_J resulting from internal power dissipation. Then, solve equation 2 for $P_{D(max)}$:

$$P_{D(max)} = \Delta T_{(max)} \div R_{\theta JA} = 15^\circ\text{C} \div 147^\circ\text{C/W} = 102\text{ mW}$$

Finally, solve equation 1 with respect to supply voltage:

$$V_{CC(est)} = P_{D(max)} \div I_{CC} = 102\text{ mW} \div 10\text{ mA} = 10.2\text{ V}$$

The result indicates that, at T_A , the application and device can dissipate adequate amounts of heat at voltages $\leq V_{CC(est)}$.

Compare $V_{CC(est)}$ to $V_{CC(max)}$. If $V_{CC(est)} \leq V_{CC(max)}$, then reliable operation between $V_{CC(est)}$ and $V_{CC(max)}$ requires enhanced $R_{\theta JA}$. If $V_{CC(est)} \geq V_{CC(max)}$, then operation between $V_{CC(est)}$ and $V_{CC(max)}$ is reliable under these conditions.

THERMAL CHARACTERISTICS: May require derating at maximum conditions

Characteristic	Symbol	Test Conditions*	Value	Unit
Package Thermal Resistance	$R_{\theta JA}$	1-layer PCB with copper limited to solder pads	147	$^\circ\text{C/W}$

*Additional thermal information available on the Allegro website.

Power Derating Curve

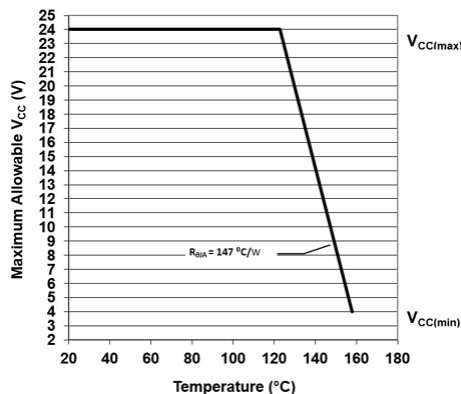

Power Dissipation versus Ambient Temperature

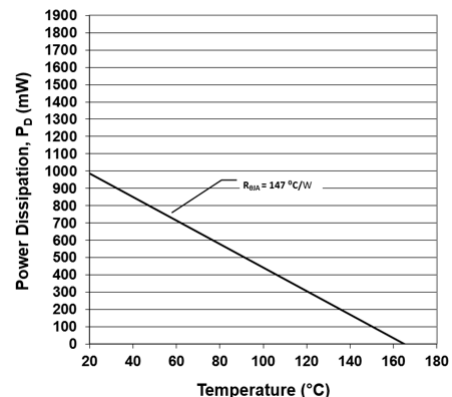

Package SM, 3-Pin SIP

For Reference Only – Not for Tooling Use

(Reference DWG-0000417, Rev. 3)

Dimensions in Millimeters – NOT TO SCALE

Dimensions exclusive of mold flash, gate burrs, and dambar protrusions
Exact case and lead configuration at supplier discretion within limits shown

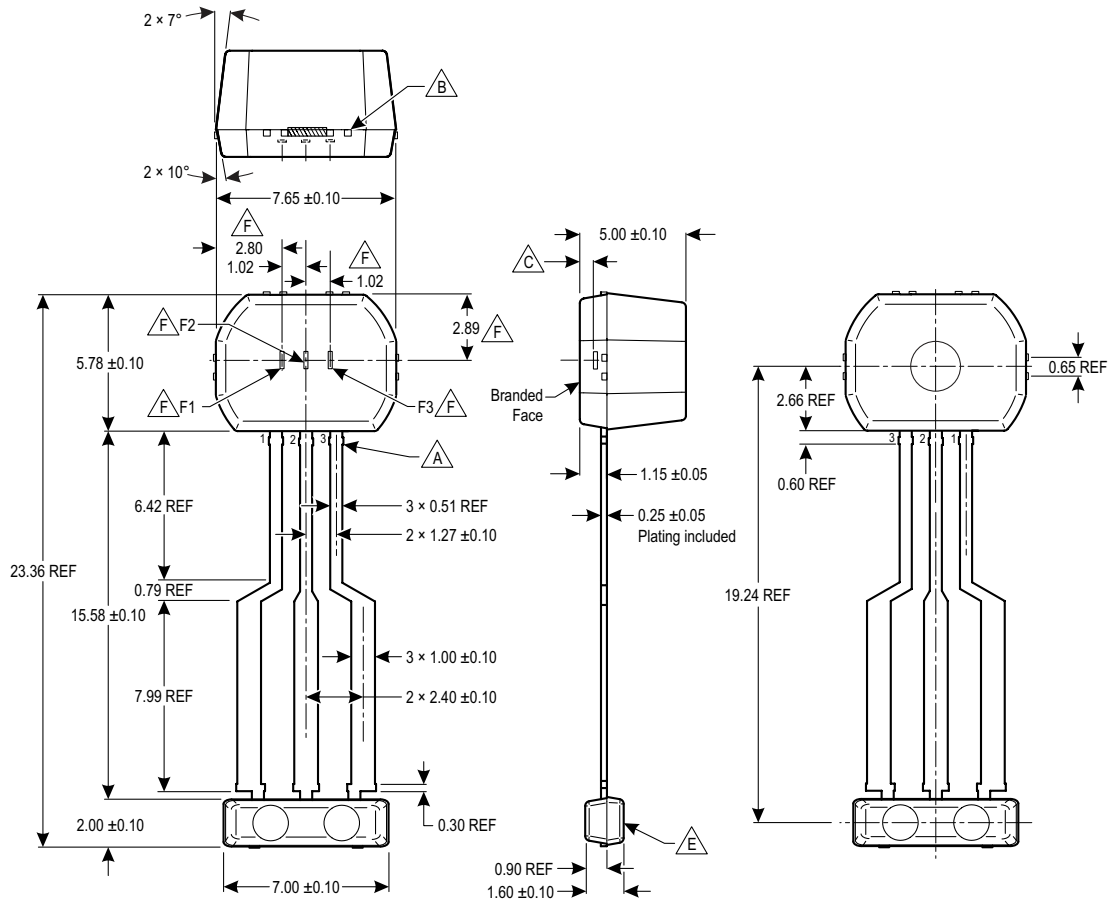

- △ A Dambar removal protrusion (12×)
- △ B Gate and tie bar burr area
- △ C Active Area Depth 0.60 ± 0.05 mm
- △ D Branding scale and appearance at supplier discretion
- △ E Molded lead bar for preventing damage to leads during shipment
- △ F GMR elements (F1, F2, and F3), not to scale

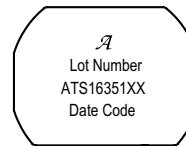

△ D Standard Branding Reference View

Lines 1, 2, 3, 4: Up to 10 characters, centered

- Line 1: Logo A
- Line 2: Characters 5, 6, 7, 8, 9, 10, 11 of Assembly Lot Number
- Line 3: Part Number:
3 character prefix (ATS),
5 digit part number (16351),
0-2 character part variant (XX).
Example: ATS16351B
- Line 4: 4 digit Date Code

Revision History

Number	Date	Description
–	March 2, 2022	Initial release

Copyright 2022, Allegro MicroSystems.

Allegro MicroSystems reserves the right to make, from time to time, such departures from the detail specifications as may be required to permit improvements in the performance, reliability, or manufacturability of its products. Before placing an order, the user is cautioned to verify that the information being relied upon is current.

Allegro's products are not to be used in any devices or systems, including but not limited to life support devices or systems, in which a failure of Allegro's product can reasonably be expected to cause bodily harm.

The information included herein is believed to be accurate and reliable. However, Allegro MicroSystems assumes no responsibility for its use; nor for any infringement of patents or other rights of third parties which may result from its use.

Copies of this document are considered uncontrolled documents.

For the latest version of this document, visit our website:

www.allegromicro.com