

TPS22960 Low-Input Voltage, Dual-Load Switch With Controlled Turnon

1 Features

- Integrated Dual-Load Switch
- Input Voltage Range: 1.62 V to 5.5 V
- Low ON-State Resistance
 - $r_{ON} = 342\text{ m}\Omega$ at $V_{IN} = 5.5\text{ V}$
 - $r_{ON} = 435\text{ m}\Omega$ at $V_{IN} = 3.3\text{ V}$
 - $r_{ON} = 523\text{ m}\Omega$ at $V_{IN} = 2.5\text{ V}$
 - $r_{ON} = 737\text{ m}\Omega$ at $V_{IN} = 1.8\text{ V}$
- 500-mA Maximum Continuous Switch Current
- Low Quiescent Current and Shutdown Current
- Controlled Switch Output Rise Time: 75 μs or 660 μs
- Integrated Quick Output Discharge Transistor
- ESD Performance Tested Per JESD 22
 - 2000-V Human Body Model (A114-B, Class II)
 - 1000-V Charged-Device Model (C101)
- 8-Pin SOT (DCN) Package: 3 mm \times 3 mm
- 8-Pin UQFN (RSE) Package: 1.5 mm \times 1.5 mm

2 Applications

- GPS Devices
- Cell Phones/PDAs
- MP3 Players
- Digital Cameras

3 Description

The TPS22960 is a small low- r_{ON} dual-channel load switch with controlled turnon. The devices contain two P-channel MOSFETs that can operate over an input voltage range of 1.62 V to 5.5 V. Each switch is independently controlled by on/off inputs (ON1 and ON2), which are capable of interfacing directly with low-voltage control signals. In TPS22960 a 85- Ω on-chip load resistor is added for quick discharge when the switch is turned off.

The rise time (slew-rate) of the device is internally controlled in order to avoid inrush current, and it can be slowed down if needed using the SR pin: at 3.3 V, TPS22960 features a 75- μs rise time with the SR pin tied to ground and 660- μs with the SR pin tied to high.

The TPS22960 is available in a space-saving 8-pin UQFN package and in an 8-pin SOT package. It is characterized for operation over the free-air temperature range of -40°C to 85°C .

Device Information⁽¹⁾

PART NUMBER	PACKAGE	BODY SIZE (NOM)
TPS22960	SOT (8)	2.90 mm \times 1.63 mm
	UQFN (8)	1.50 mm \times 1.50 mm

(1) For all available packages, see the orderable addendum at the end of the datasheet.

Simplified Diagram

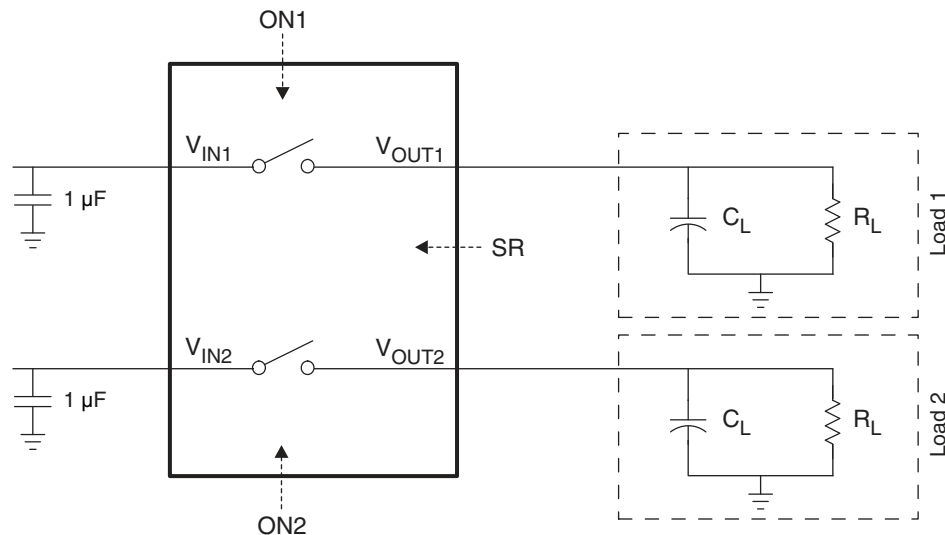

Table of Contents

1 Features 1 2 Applications 1 3 Description 1 4 Revision History 2 5 Pin Configuration and Functions 3 6 Specifications 3 6.1 Absolute Maximum Ratings 3 6.2 ESD Ratings 3 6.3 Recommended Operating Conditions 4 6.4 Thermal Information 4 6.5 Electrical Characteristics 5 6.6 Switching Characteristics 5 6.7 Typical DC Characteristics 6 6.8 Typical Switching Characteristics 7 7 Parameter Measurement Information 11 8 Detailed Description 12 8.1 Overview 12	8.2 Functional Block Diagram 12 8.3 Feature Description 13 8.4 Device Functional Modes 13 9 Application and Implementation 14 9.1 Application Information 14 9.2 Typical Application 14 10 Power Supply Recommendations 16 11 Layout 16 11.1 Layout Guidelines 16 11.2 Layout Example 17 12 Device and Documentation Support 19 12.1 Community Resources 19 12.2 Trademarks 19 12.3 Electrostatic Discharge Caution 19 12.4 Glossary 19 13 Mechanical, Packaging, and Orderable Information 19
--	--

4 Revision History

NOTE: Page numbers for previous revisions may differ from page numbers in the current version.

Changes from Revision C (July 2015) to Revision D	Page
• Made changes to Application Information	1

Changes from Revision B (August 2013) to Revision C	Page
• Added <i>Pin Configuration and Functions</i> section, <i>ESD Ratings</i> table, <i>Feature Description</i> section, <i>Device Functional Modes</i> , <i>Application and Implementation</i> section, <i>Power Supply Recommendations</i> section, <i>Layout</i> section, <i>Device and Documentation Support</i> section, and <i>Mechanical, Packaging, and Orderable Information</i> section	1
• Updated the Thermal Information table to remove 220°C/W and 116°C/W from the junction-to-ambient thermal resistance, and 123°C/W and 60°C/W from the junction-to-case (top) thermal resistance	4
• Changed values > 100°C/W in the Thermal Information table to contain only 3 significant figures	4

Changes from Revision A (August 2011) to Revision B	Page
• Clarified text in the Description	1
• Added T_J to the Absolute Maximum Ratings table	3
• Updated Table 2 in Device Functional Modes	13

Changes from Original (April 2009) to Revision A	Page
• Changed r_{ON} values for $V_{INX} = 1.8\text{ V}$ (25°C) From: Typ 714, Max 855 To: Typ 737, Max 1100	5
• Changed r_{ON} values for $V_{INX} = 1.8\text{ V}$ (Full) From: Max 995 To: Max 1300	5
• Changed r_{ON} values for $V_{INX} = 1.62\text{ V}$ (25°C) From: Typ 830, Max 950 To: Typ 848, Max 1300	5
• Changed r_{ON} values for $V_{INX} = 1.62\text{ V}$ (Full) From: Max 1100 To: Max 1500	5

5 Pin Configuration and Functions

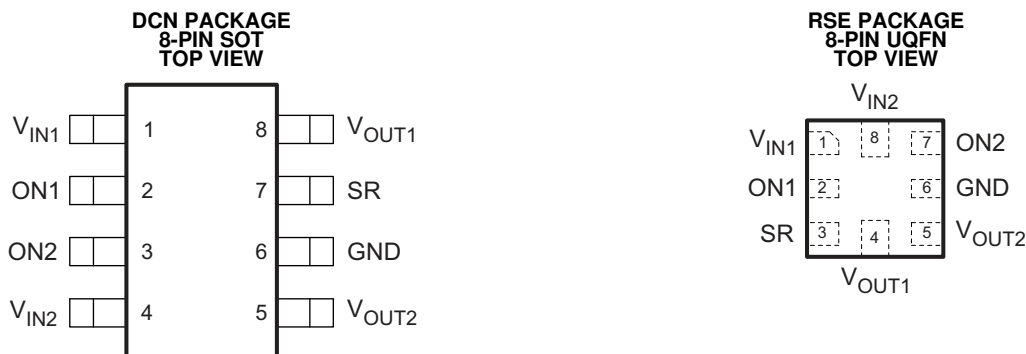

Pin Functions

PIN			I/O	DESCRIPTION
NAME	SOT	UQFN		
V _{IN1}	1	1	I	Switch 1 input; bypass this input with a ceramic capacitor to GND
ON1	2	2	I	Switch 1 control input, active high. Do not leave floating.
ON2	3	7	I	Switch 2 control input, active high. Do not leave floating.
V _{IN2}	4	8	I	Switch 2 input; bypass this input with a ceramic capacitor to GND
V _{OUT2}	5	5	O	Switch 2 output
GND	6	6	—	Ground
SR	7	3	I	Slew rate control pin. SR = GND translates into a 75- μ s rise time; SR = high translates into a 660- μ s rise time
V _{OUT1}	8	4	O	Switch 1 output

6 Specifications

6.1 Absolute Maximum Ratings

(see ⁽¹⁾)

		MIN	MAX	UNIT
V _{IN}	Input voltage	-0.3	6	V
V _{OUT}	Output voltage		V _{IN} + 0.3	V
V _{ON}	Input voltage	-0.3	6	V
I _{MAX}	Maximum continuous switch current		0.5	A
T _A	Operating free-air temperature	-40	85	°C
T _J	Maximum junction temperature		125	°C
T _{stg}	Storage temperature	-65	150	°C

- (1) Stresses beyond those listed under absolute maximum ratings may cause permanent damage to the device. These are stress ratings only, and functional operation of the device at these or any other conditions beyond those indicated under *Recommended Operating Conditions* is not implied. Exposure to absolute-maximum-rated conditions for extended periods may affect device reliability.

6.2 ESD Ratings

		VALUE	UNIT
V _(ESD)	Electrostatic discharge	Human body model (HBM), per ANSI/ESDA/JEDEC JS-001 ⁽¹⁾	2000
		Charged-device model (CDM), per JEDEC specification JESD22-C101 ⁽²⁾	1000

- (1) JEDEC document JEP155 states that 500-V HBM allows safe manufacturing with a standard ESD control process.
(2) JEDEC document JEP157 states that 250-V CDM allows safe manufacturing with a standard ESD control process.

6.3 Recommended Operating Conditions

		MIN	MAX	UNIT	
V _{IN}	Input voltage	1.62	5.5	V	
V _{OUT}	Output voltage		V _{IN}	V	
V _{IH}	High-level input voltage: ON1, ON2, SR	V _{INx} = 3.0 V to 5.5 V	1.5	5.5	V
		V _{INx} = 1.62 V to 3.0 V	1.4	5.5	
V _{IL}	Low-level input voltage: ON1, ON2, SR	V _{INx} = 3.0 V to 5.5 V		0.5	V
		V _{INx} = 1.62 V to 3.0 V		0.4	
C _{IN}	Input capacitor		1 ⁽¹⁾	μF	

(1) See [Application Information](#)

6.4 Thermal Information

THERMAL METRIC ⁽¹⁾		TPS22960		UNIT
		DCN (SOT)	RSE (UQFN)	
		8 PINS	8 PINS	
R _{θJA}	Junction-to-ambient thermal resistance	254	124	°C/W
R _{θJC(top)}	Junction-to-case (top) thermal resistance	122	67	°C/W
R _{θJB}	Junction-to-board thermal resistance	181	31.5	°C/W
ψ _{JT}	Junction-to-top characterization parameter	22	2.9	°C/W
ψ _{JB}	Junction-to-board characterization parameter	178	31.5	°C/W
R _{θJC(bot)}	Junction-to-case (bottom) thermal resistance	—	—	°C/W

(1) For more information about traditional and new thermal metrics, see *Semiconductor and IC Package Thermal Metrics* ([SPRA953](#)).

6.5 Electrical Characteristics

 $V_{IN} = 1.62\text{ V to } 5.5\text{ V}$, $T_A = -40^\circ\text{C to } 85^\circ\text{C}$ (unless otherwise noted)

PARAMETER		TEST CONDITIONS	T_A	MIN	TYP ⁽¹⁾	MAX	UNIT
I_{IN}	Quiescent current (each switch)	$I_{OUTx} = 0$, $V_{INx} = V_{ON}$	$V_{INx} = 5.5\text{ V}$	Full	0.64	2	μA
			$V_{INx} = 3.3\text{ V}$	Full	0.35	1.2	
			$V_{INx} = 2.5\text{ V}$	Full	0.24	0.8	
			$V_{INx} = 1.8\text{ V}$	Full	0.15	0.5	
$I_{IN(OFF)}$	OFF-state supply current (each switch)	$V_{ON} = \text{GND}$, $V_{OUTx} = \text{Open}$	$V_{INx} = 5.5\text{ V}$	Full	0.47	3.6	μA
			$V_{INx} = 3.3\text{ V}$	Full	0.25	1.8	
			$V_{INx} = 2.5\text{ V}$	Full	0.18	1.3	
			$V_{INx} = 1.8\text{ V}$	Full	0.11	0.9	
r_{ON}	ON-state resistance (each switch)	$I_{OUT} = -200\text{ mA}$	$V_{INx} = 5.5\text{ V}$	25°C	342	400	$\text{m}\Omega$
				Full		465	
			$V_{INx} = 3.3\text{ V}$	25°C	435	500	
				Full		595	
			$V_{INx} = 2.5\text{ V}$	25°C	523	620	
				Full		720	
			$V_{INx} = 1.8\text{ V}$	25°C	737	1100	
				Full		1300	
$V_{INx} = 1.62\text{ V}$	25°C	848	1300				
	Full		1500				
r_{PD}	Output pulldown resistance	$V_{IN} = 3.3\text{ V}$, $V_{ON} = 0$, $I_{OUT} = 30\text{ mA}$	25°C	85	120	Ω	
I_{ON}	ON-state input leakage current	$V_{ON} = 1.62\text{ V to } 5.5\text{ V or GND}$	Full		0.25	μA	

 (1) Typical values are at $T_A = 25^\circ\text{C}$.

6.6 Switching Characteristics

 $V_{IN} = 3.3\text{ V}$, $T_A = 25^\circ\text{C}$, $R_{L_CHIP} = 85\ \Omega$ (unless otherwise noted)

PARAMETER		TEST CONDITIONS	MIN	TYP ⁽¹⁾	MAX	UNIT
t_{ON}	Turn-ON time	$R_L = 33\ \Omega$, $C_L = 0.1\ \mu\text{F}$	$SR = V_{IN}$	635		μs
			$SR = \text{GND}$	67		
t_{OFF}	Turn-OFF time	$R_L = 33\ \Omega$, $C_L = 0.1\ \mu\text{F}$	$SR = V_{IN}$	4.5		μs
			$SR = \text{GND}$	4.2		
t_r	V_{OUT} rise time	$R_L = 33\ \Omega$, $C_L = 0.1\ \mu\text{F}$	$SR = V_{IN}$	660		μs
			$SR = \text{GND}$	75		
t_f	V_{OUT} fall time	$R_L = 33\ \Omega$, $C_L = 0.1\ \mu\text{F}$	$SR = V_{IN}$	4.5		μs
			$SR = \text{GND}$	4.5		

 (1) Typical values are at the specified $V_{IN} = 3.3\text{ V}$ and $T_A = 25^\circ\text{C}$

6.7 Typical DC Characteristics

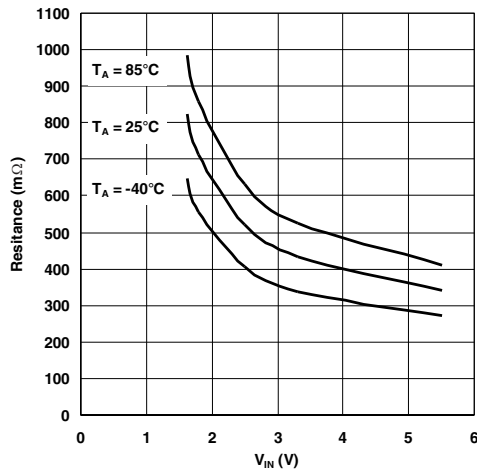

Figure 1. ON Resistance vs Input Voltage

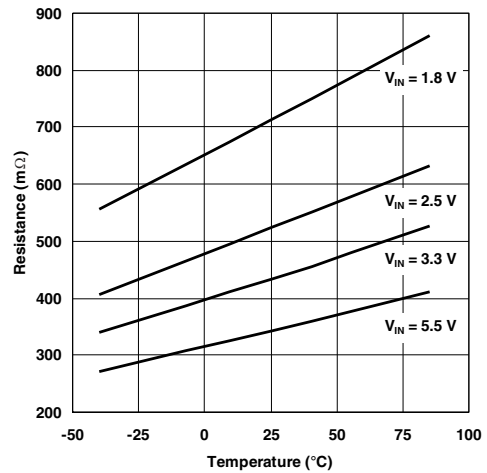

Figure 2. ON Resistance vs Temperature

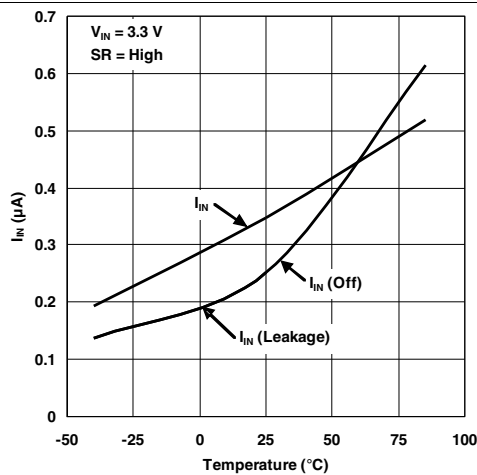

Figure 3. Quiescent Current vs Temperature

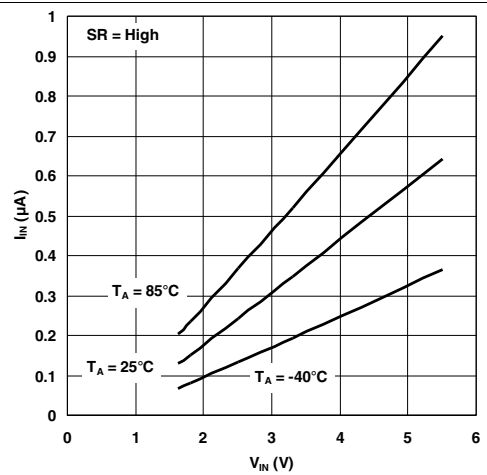

Figure 4. Quiescent Current vs Input Voltage

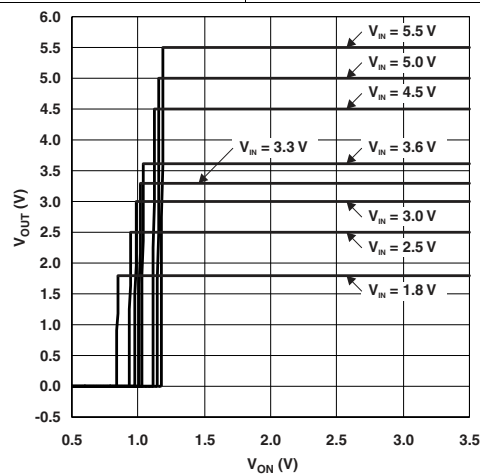

Figure 5. ON Threshold

6.8 Typical Switching Characteristics

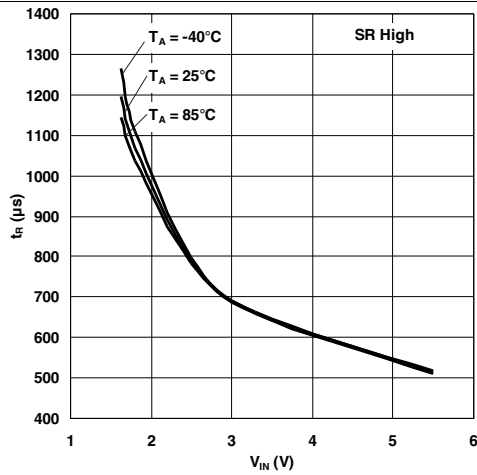

Figure 6. Rise Time vs Input Voltage

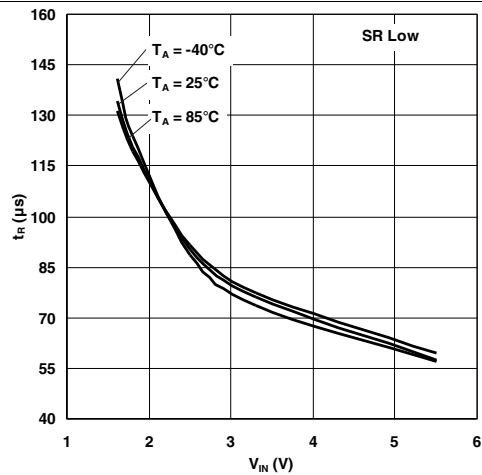

Figure 7. Rise Time vs Input Voltage

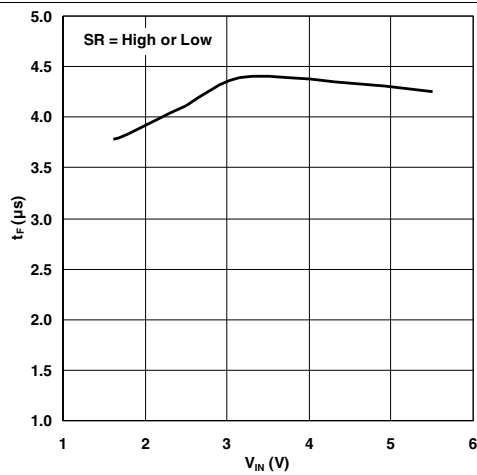

Figure 8. Fall Time vs Input Voltage

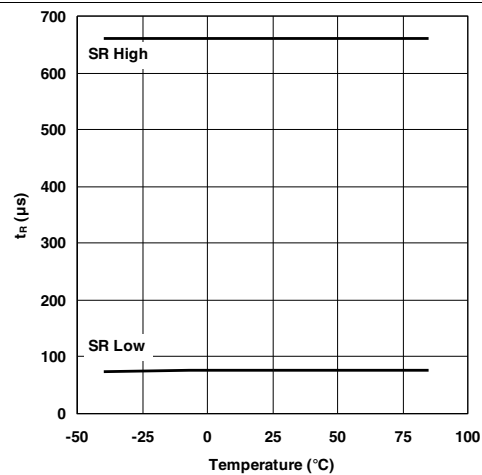

Figure 9. Rise Time vs Temperature

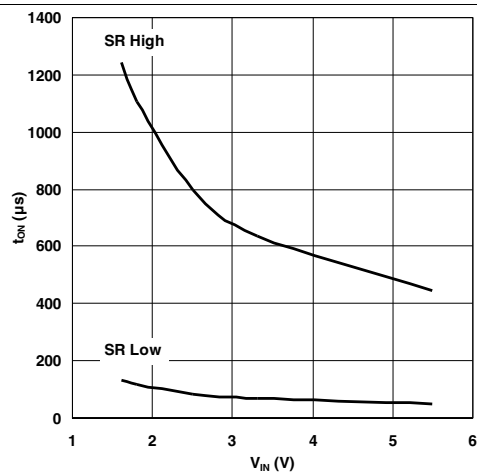

Figure 10. On Time vs Input Voltage

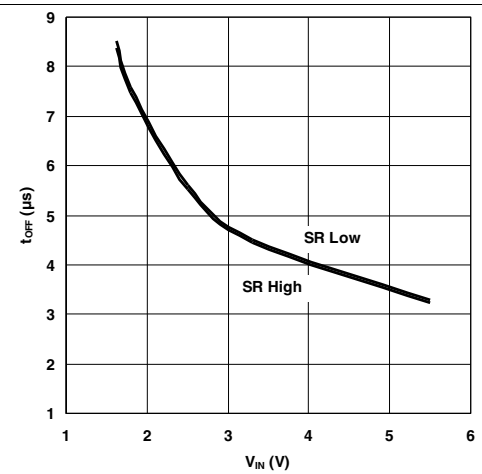
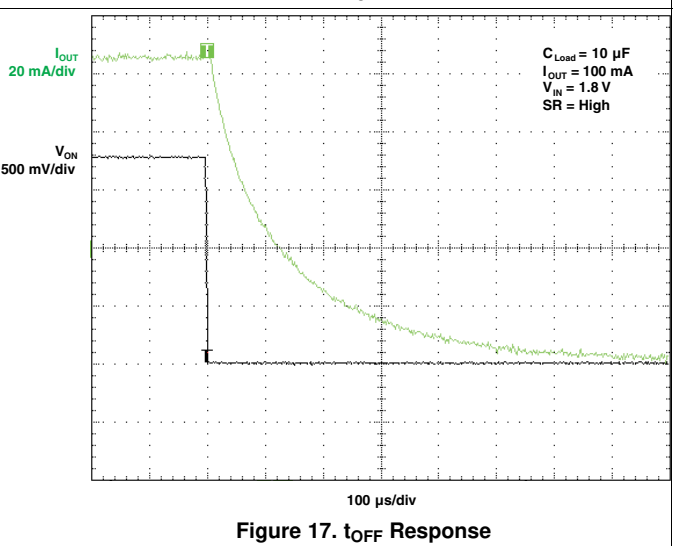
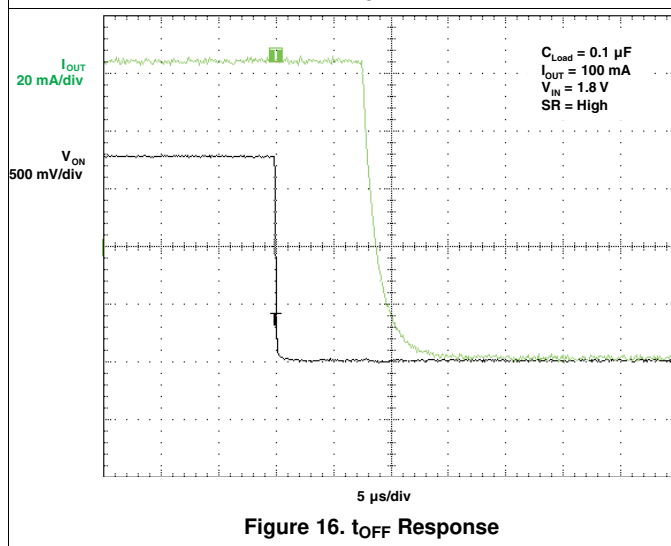
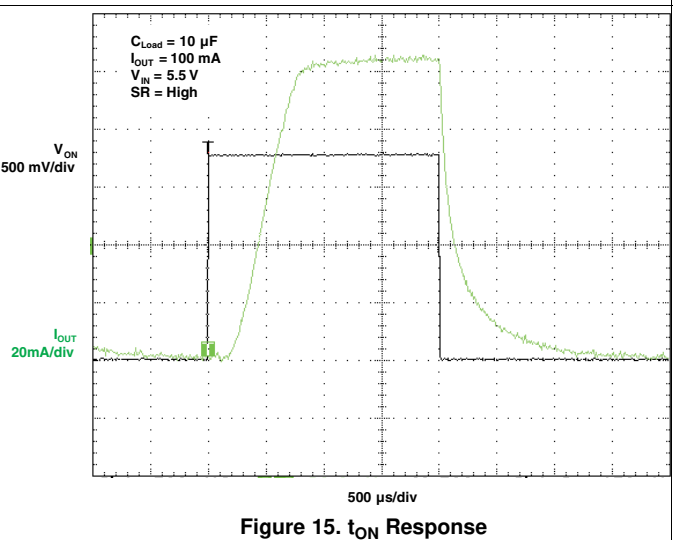
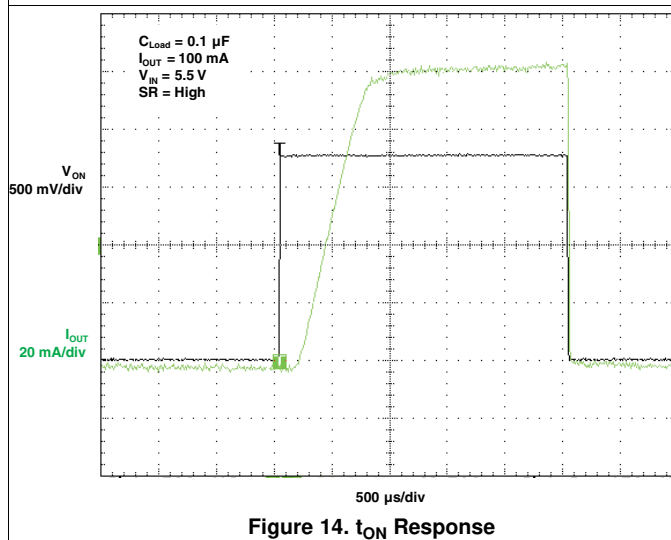
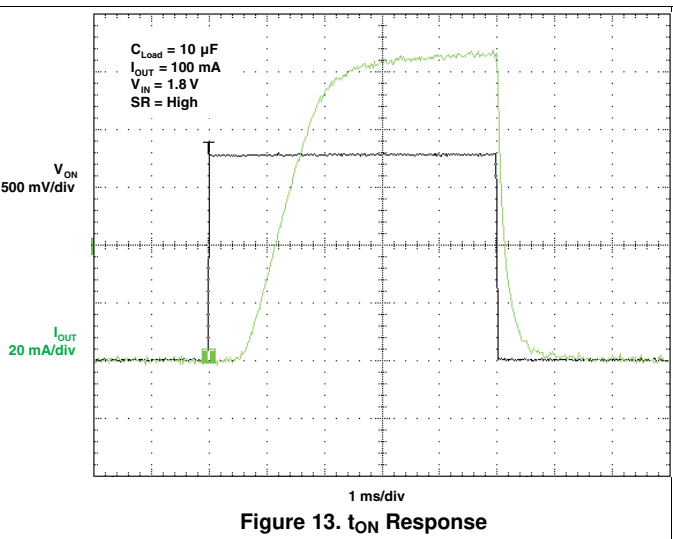
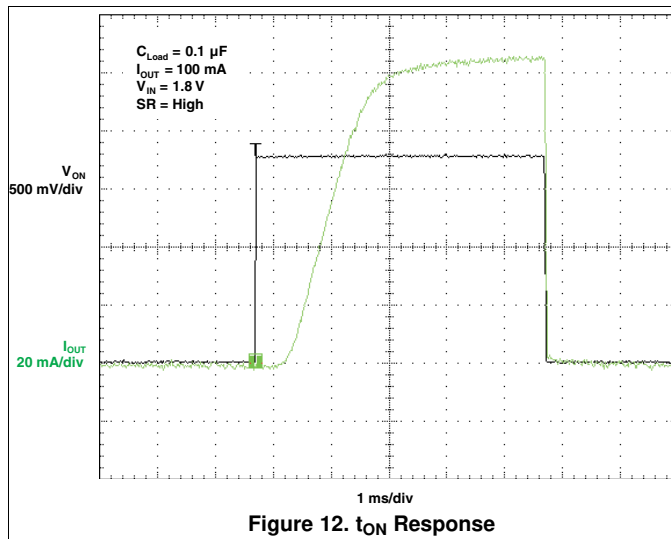

Figure 11. Off Time vs Input Voltage

Typical Switching Characteristics (continued)

Typical Switching Characteristics (continued)

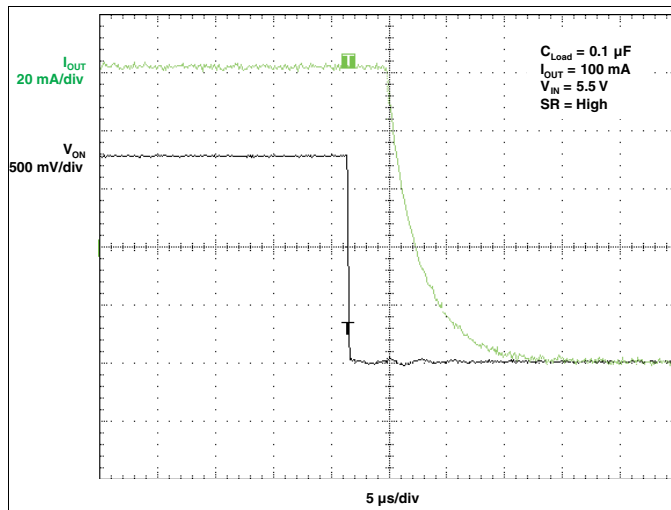

Figure 18. t_{OFF} Response

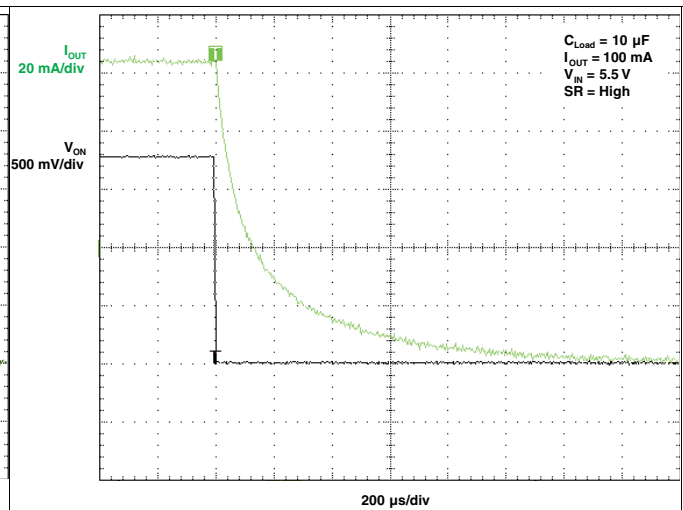

Figure 19. t_{OFF} Response

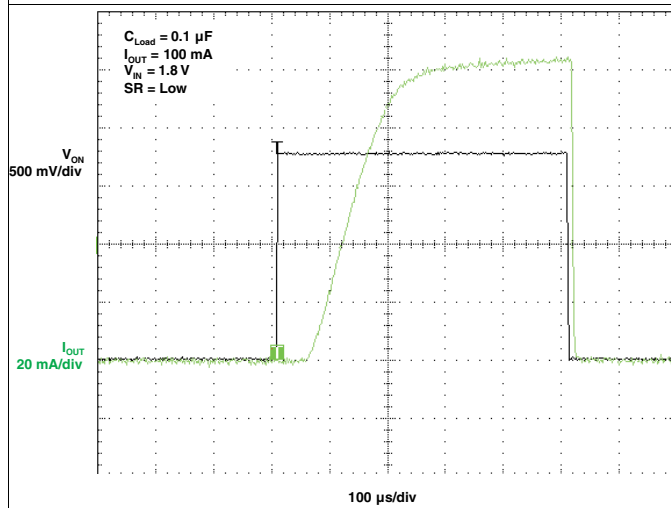

Figure 20. t_{ON} Response

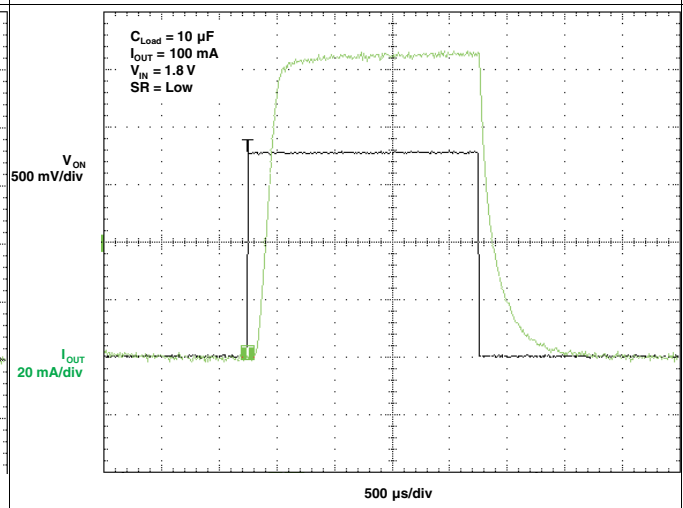

Figure 21. t_{ON} Response

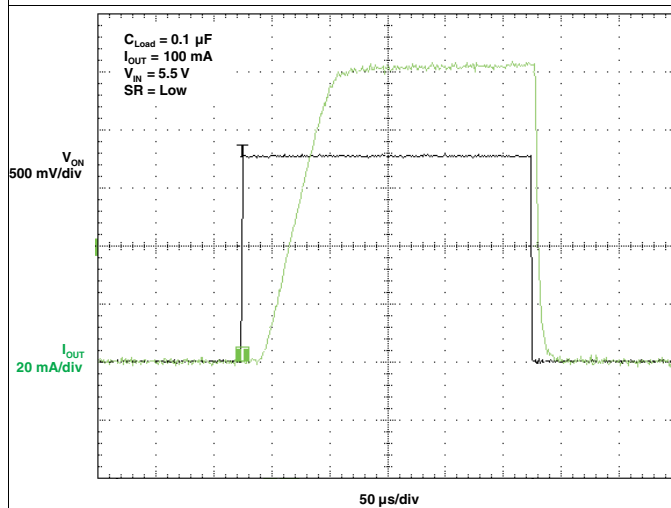

Figure 22. t_{ON} Response

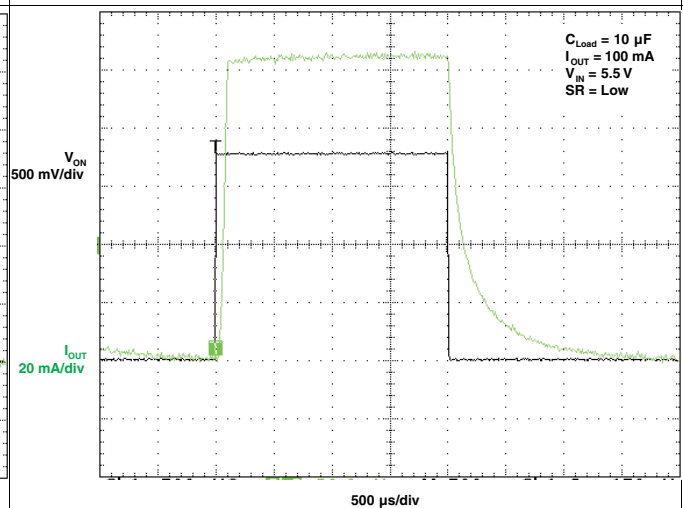
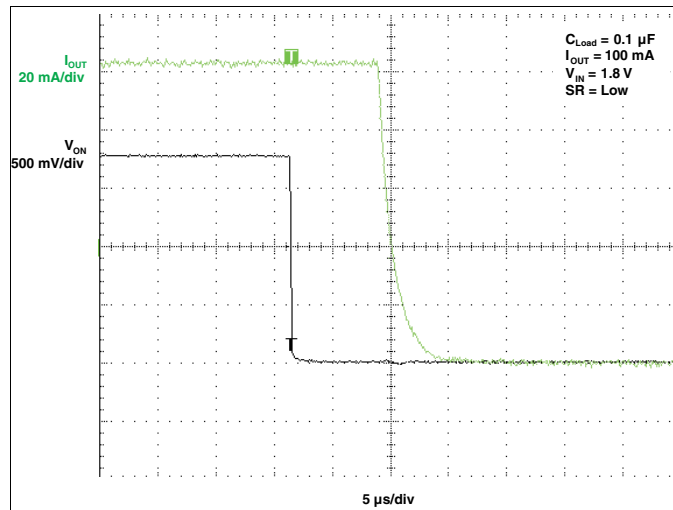
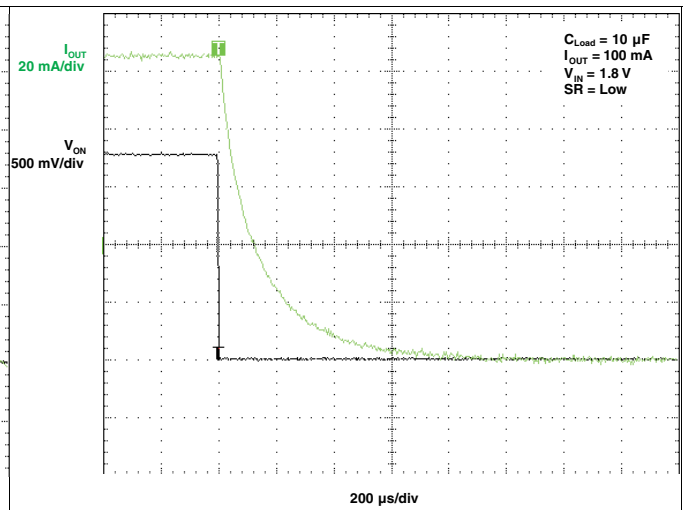
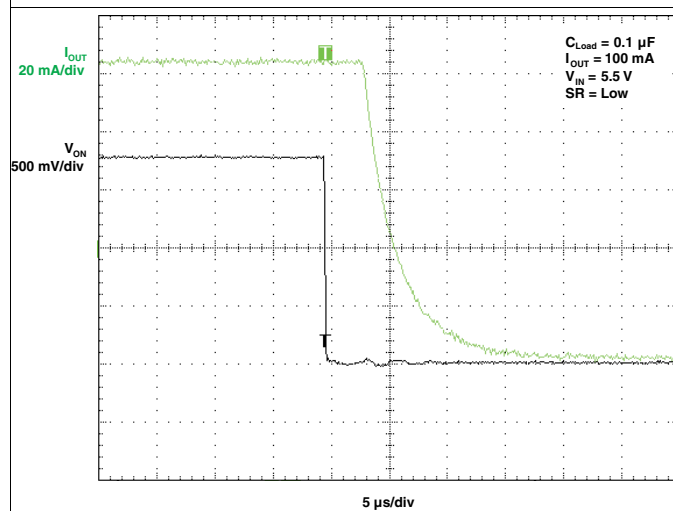
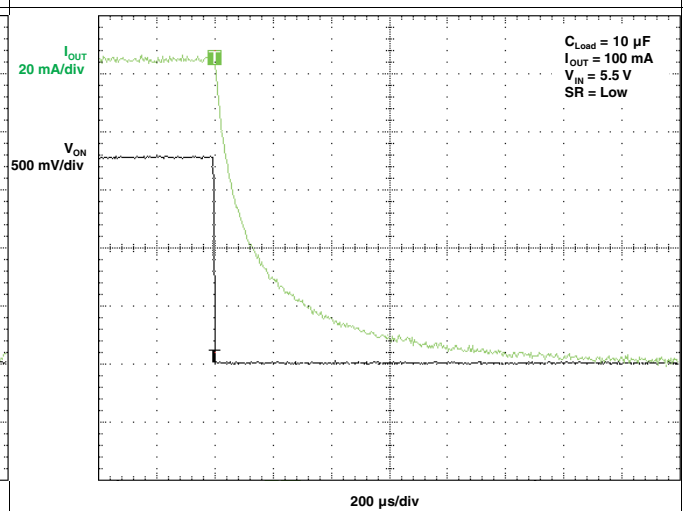
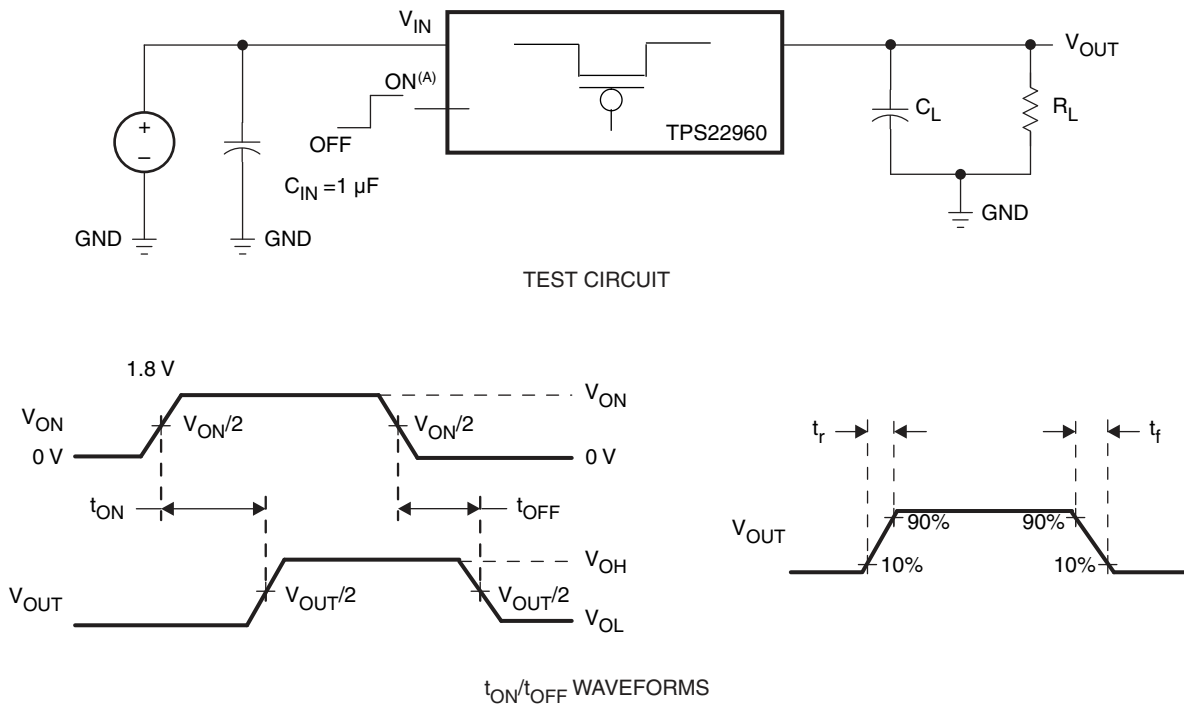

Figure 23. t_{ON} Response

Typical Switching Characteristics (continued)

Figure 24. t_{OFF} Response

Figure 25. t_{OFF} Response

Figure 26. t_{OFF} Response

Figure 27. t_{OFF} Response

7 Parameter Measurement Information



A. t_{rise} and t_{fall} of the control signal is 100 ns.

Figure 28. Test Circuit and t_{ON}/t_{OFF} Waveforms

8 Detailed Description

8.1 Overview

The TPS22960 is a dual-channel load switch. The two channels can be independently controlled using the ONx pins. Each channel has an 85-Ω quick discharge resistance from V_{OUTX} to GND when disabled. A single control pin (SR) is used to set the slew rate for both channels..

8.2 Functional Block Diagram

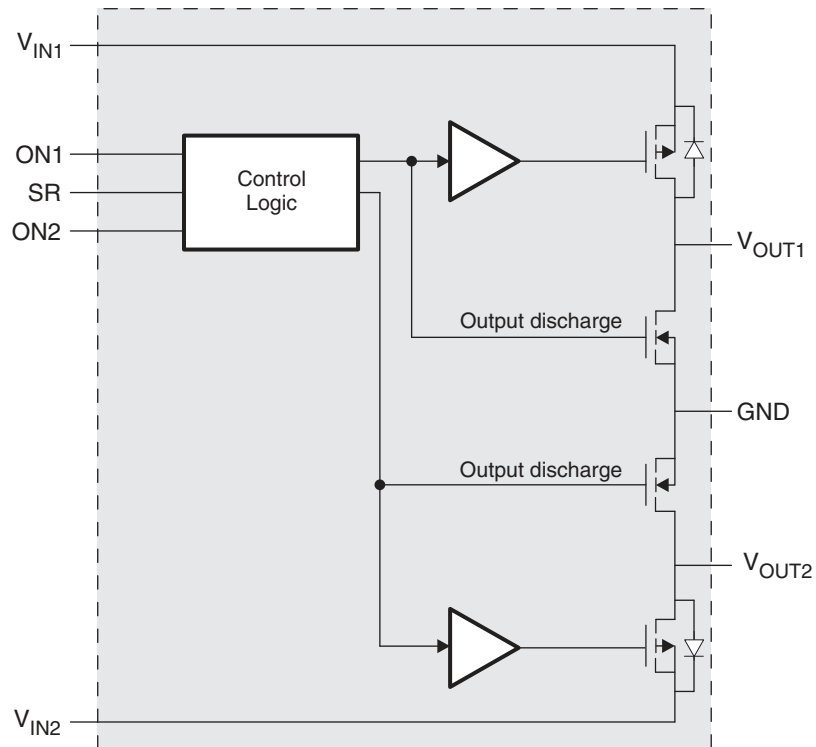

8.3 Feature Description

This section will discuss the features of the TPS22960 which have been summarized in [Table 1](#).

Table 1. Feature Summary

DEVICE	r _{ON} AT 3.3 V (TYP)	SLEW RATE AT 3.3 V (TYP)	QUICK OUTPUT DISCHARGE ⁽¹⁾	MAX OUTPUT CURRENT	ENABLE
TPS22960	435 mΩ	75 μs with SR = low 660 μs with SR = high	Yes	500 mA	Active High

(1) This feature discharges the output of the switch to ground through an 85-Ω resistor, preventing the output from floating.

8.3.1 Output Slew Rate (SR) Control

The slew rate (rise time) of the device is internally controlled in order to avoid inrush current, and it can be slowed down if needed using the SR pin. At 3.3 V, TPS22960 features a 75-μs rise time with the SR pin tied to ground, and a 660-μs rise time with the SR pin tied high. Both channels will have the same slew rate set by the SR pin.

8.3.2 Quick Output Discharge (QOD)

Each channel of the TPS22960 includes an independent QOD feature. When the channel is disabled, a discharge resistor is connected between V_{OUTx} and GND. This resistor has a typical value of 85 Ω and prevents the output from floating while the switch is disabled.

8.4 Device Functional Modes

Table 2. Configurable Logic Function Table

ONx	V _{INx} TO V _{OUTx}	V _{OUTx} TO GND
L	OFF	ON
H	ON	OFF

9 Application and Implementation

NOTE

Information in the following applications sections is not part of the TI component specification, and TI does not warrant its accuracy or completeness. TI's customers are responsible for determining suitability of components for their purposes. Customers should validate and test their design implementation to confirm system functionality.

9.1 Application Information

9.1.1 ON/OFF Control

The ON pin controls the state of the switch. Activating ON continuously holds the switch in the on state, as long as there is no fault. ON is active HI and has a low threshold, making it capable of interfacing with low voltage signals. The ON pin is compatible with standard GPIO logic threshold. It can be used with any microcontroller with 1.2-V, 1.8-V, 2.5-V, or 3.3-V GPIOs.

9.1.2 Input Capacitor

To limit voltage drop or voltage transients, sufficient capacitance needs to be placed on the input side of the load switch (from V_{IN} to GND). In most cases, a 1- μ F ceramic capacitor, C_{IN} , placed close to the pins is usually sufficient. However, when switching heavy capacitive loads, higher values of C_{IN} may be needed to prevent the system supply voltage from dropping.

9.1.3 Output Capacitor

The integral body diode in the PMOS switch will allow reverse current flow if V_{OUT} exceeds V_{IN} . A C_L greater than C_{IN} can cause V_{OUT} to exceed V_{IN} if the system supply is removed. In the case where the system supply could be removed and reverse current is a concern, a C_L greater than C_L is recommended.

9.2 Typical Application

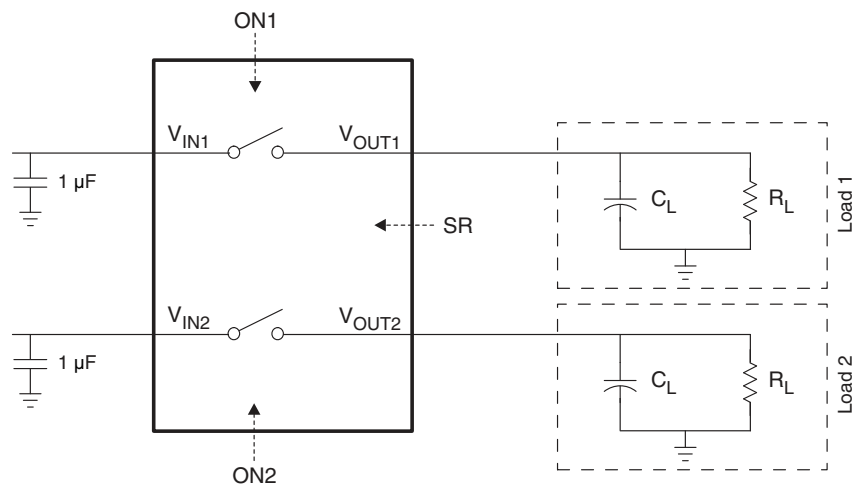

Figure 29. Typical Application Schematic

Typical Application (continued)

9.2.1 Design Requirements

For this design example, use input parameters in [Table 3](#).

Table 3. Design Parameters

PARAMETER	EXAMPLE VALUE
V _{IN}	3.3 V
C _L	22 μF
Maximum acceptable inrush current	200 mA

9.2.2 Detailed Design Procedure

9.2.2.1 Inrush Current

When the switch is enabled, the output capacitors must be charged up from 0 V to the set value (in this example, 3.3 V). This charge arrives in the form of inrush current. Inrush current can be calculated using the following equation:

$$\text{Inrush Current} = C \times dV / dt \tag{1}$$

Where:

- C = output capacitance
- dV = output voltage
- dt = rise time

The TPS22960 offers selectable rise time control for V_{OUT}. This feature allows the user to control the inrush current during turnon. [Equation 1](#) can be used to find the required rise time to limit the inrush current to the design requirements

$$200 \text{ mA} = 22 \mu\text{F} \times (3.3 \text{ V} \times 80\%) / dt \tag{2}$$

$$dt = 290 \mu\text{s} \tag{4}$$

To ensure an inrush current of less than 200 mA, SR must be set high for a rise time greater than 290 μs. The following application curves show the different inrush for each SR setting in this design example.

9.2.3 Application Curves

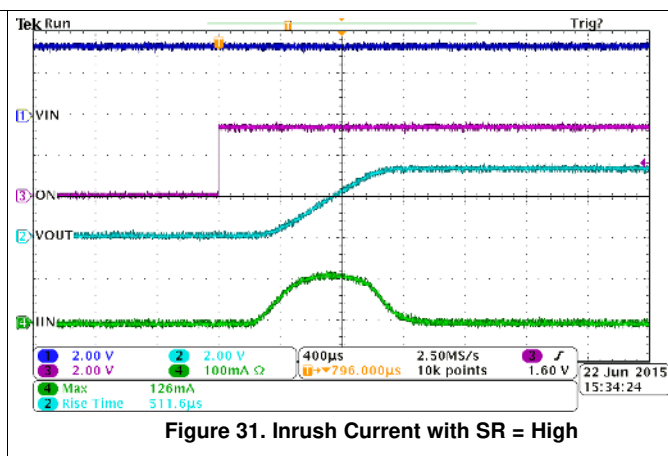
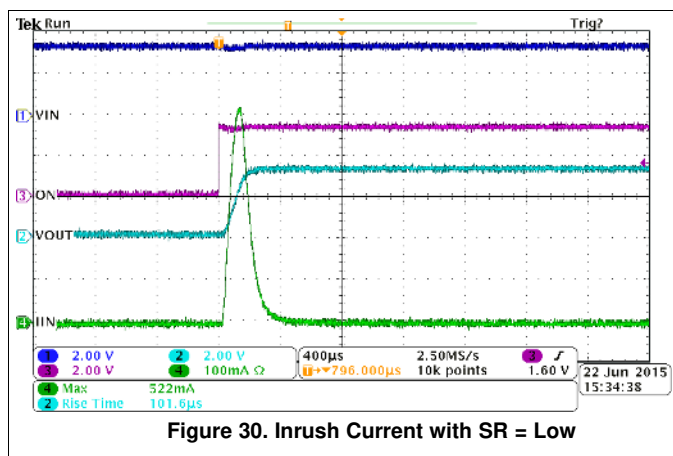

10 Power Supply Recommendations

The device is designed to operate from an input voltage range of 1.62 V to 5.5 V. The power supply should be well-regulated and placed as close to the device terminals as possible. It must be able to withstand all transient and load current steps. In most situations, using an input capacitance of 1 μF is sufficient to prevent the supply voltage from dipping when the switch is turned on. In cases where the power supply is slow to respond to a large transient current or large load current step, additional bulk capacitance may be required on the input.

The requirements for larger input capacitance can be mitigated by selecting the slower slew rate $+SR=\text{high}$. This will cause the load switch to turn on more slowly and limit the inrush current.

11 Layout

11.1 Layout Guidelines

For best performance, all traces should be as short as possible. To be most effective, the input and output capacitors should be placed close to the device to minimize the effects that parasitic trace inductances may have on normal and short-circuit operation. Using wide traces for V_{IN} , V_{OUT} , and GND will help minimize the parasitic electrical effects along with minimizing the case to ambient thermal impedance.

11.2 Layout Example

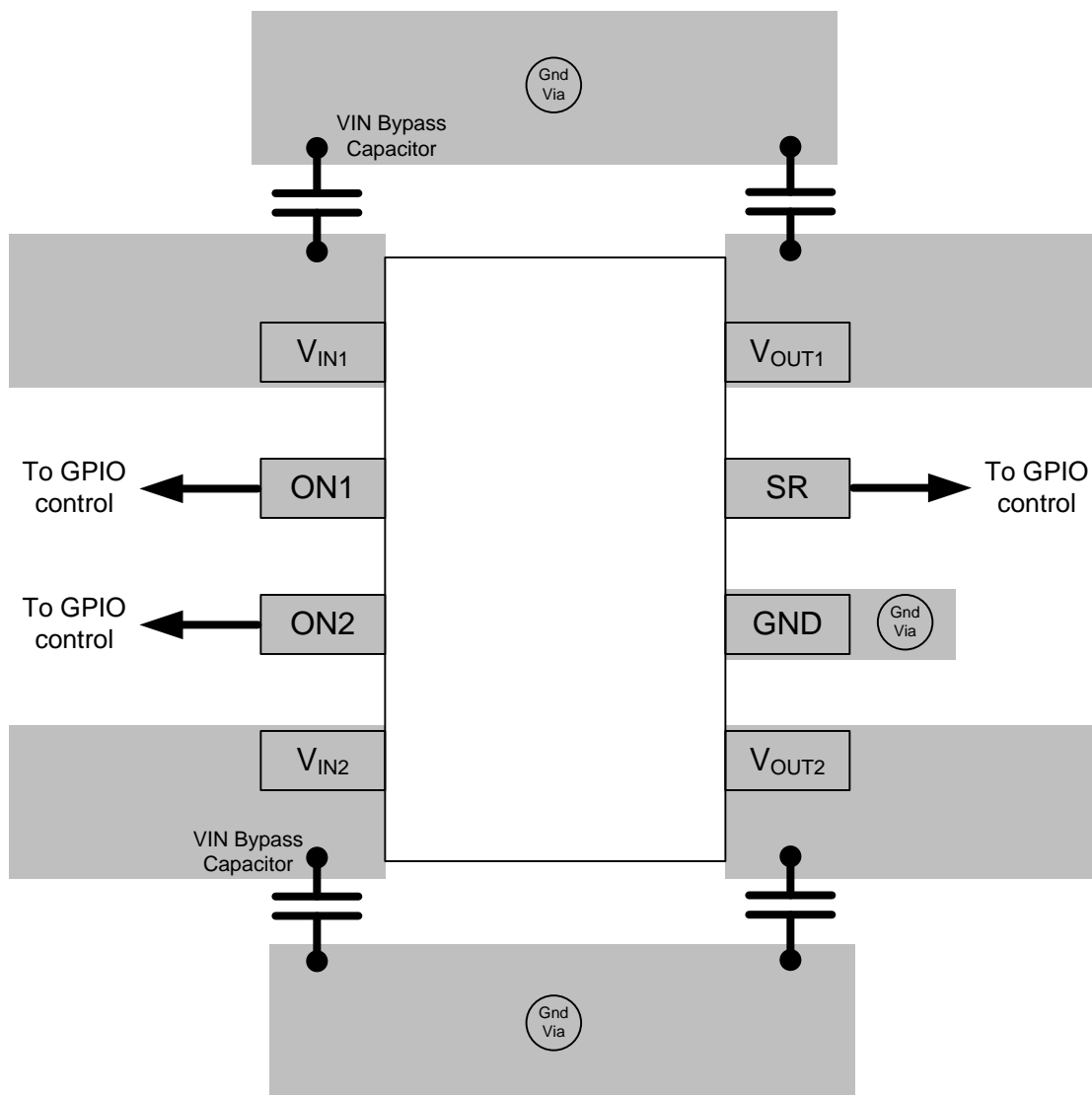

Figure 32. DCN Package Layout

Layout Example (continued)

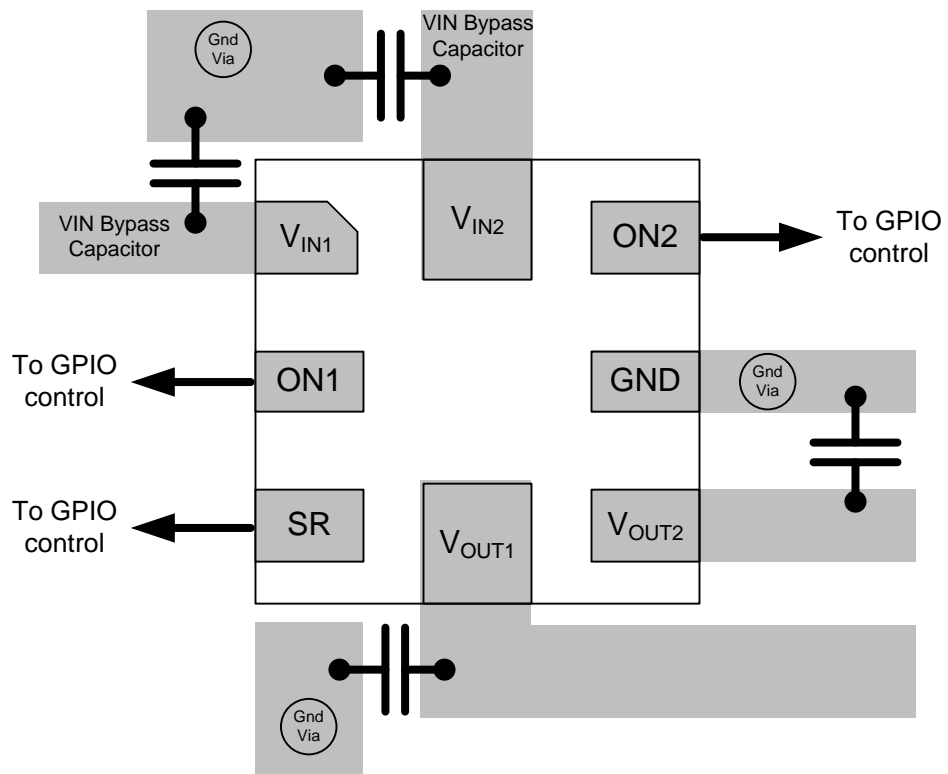

Figure 33. RSE Package Layout

12 Device and Documentation Support

12.1 Community Resources

The following links connect to TI community resources. Linked contents are provided "AS IS" by the respective contributors. They do not constitute TI specifications and do not necessarily reflect TI's views; see TI's [Terms of Use](#).

TI E2E™ Online Community *TI's Engineer-to-Engineer (E2E) Community*. Created to foster collaboration among engineers. At e2e.ti.com, you can ask questions, share knowledge, explore ideas and help solve problems with fellow engineers.

Design Support *TI's Design Support* Quickly find helpful E2E forums along with design support tools and contact information for technical support.

12.2 Trademarks

E2E is a trademark of Texas Instruments.
All other trademarks are the property of their respective owners.

12.3 Electrostatic Discharge Caution



These devices have limited built-in ESD protection. The leads should be shorted together or the device placed in conductive foam during storage or handling to prevent electrostatic damage to the MOS gates.

12.4 Glossary

[SLYZ022](#) — *TI Glossary*.

This glossary lists and explains terms, acronyms, and definitions.

13 Mechanical, Packaging, and Orderable Information

The following pages include mechanical, packaging, and orderable information. This information is the most current data available for the designated devices. This data is subject to change without notice and revision of this document. For browser-based versions of this data sheet, refer to the left-hand navigation.

PACKAGING INFORMATION

Orderable Device	Status (1)	Package Type	Package Drawing	Pins	Package Qty	Eco Plan (2)	Lead finish/ Ball material (6)	MSL Peak Temp (3)	Op Temp (°C)	Device Marking (4/5)	Samples
TPS22960DCNR	ACTIVE	SOT-23	DCN	8	3000	RoHS & Green	NIPDAU	Level-1-260C-UNLIM	-40 to 85	(NFRO, NFRR)	Samples
TPS22960RSER	ACTIVE	UQFN	RSE	8	3000	RoHS & Green	NIPDAUAG	Level-1-260C-UNLIM	-40 to 85	72	Samples
TPS22960RSET	ACTIVE	UQFN	RSE	8	250	RoHS & Green	NIPDAUAG	Level-1-260C-UNLIM	-40 to 85	72	Samples

(1) The marketing status values are defined as follows:

ACTIVE: Product device recommended for new designs.

LIFEBUY: TI has announced that the device will be discontinued, and a lifetime-buy period is in effect.

NRND: Not recommended for new designs. Device is in production to support existing customers, but TI does not recommend using this part in a new design.

PREVIEW: Device has been announced but is not in production. Samples may or may not be available.

OBSOLETE: TI has discontinued the production of the device.

(2) **RoHS:** TI defines "RoHS" to mean semiconductor products that are compliant with the current EU RoHS requirements for all 10 RoHS substances, including the requirement that RoHS substance do not exceed 0.1% by weight in homogeneous materials. Where designed to be soldered at high temperatures, "RoHS" products are suitable for use in specified lead-free processes. TI may reference these types of products as "Pb-Free".

RoHS Exempt: TI defines "RoHS Exempt" to mean products that contain lead but are compliant with EU RoHS pursuant to a specific EU RoHS exemption.

Green: TI defines "Green" to mean the content of Chlorine (Cl) and Bromine (Br) based flame retardants meet JS709B low halogen requirements of <=1000ppm threshold. Antimony trioxide based flame retardants must also meet the <=1000ppm threshold requirement.

(3) MSL, Peak Temp. - The Moisture Sensitivity Level rating according to the JEDEC industry standard classifications, and peak solder temperature.

(4) There may be additional marking, which relates to the logo, the lot trace code information, or the environmental category on the device.

(5) Multiple Device Markings will be inside parentheses. Only one Device Marking contained in parentheses and separated by a "~" will appear on a device. If a line is indented then it is a continuation of the previous line and the two combined represent the entire Device Marking for that device.

(6) Lead finish/Ball material - Orderable Devices may have multiple material finish options. Finish options are separated by a vertical ruled line. Lead finish/Ball material values may wrap to two lines if the finish value exceeds the maximum column width.

Important Information and Disclaimer:The information provided on this page represents TI's knowledge and belief as of the date that it is provided. TI bases its knowledge and belief on information provided by third parties, and makes no representation or warranty as to the accuracy of such information. Efforts are underway to better integrate information from third parties. TI has taken and continues to take reasonable steps to provide representative and accurate information but may not have conducted destructive testing or chemical analysis on incoming materials and chemicals. TI and TI suppliers consider certain information to be proprietary, and thus CAS numbers and other limited information may not be available for release.

In no event shall TI's liability arising out of such information exceed the total purchase price of the TI part(s) at issue in this document sold by TI to Customer on an annual basis.

TAPE AND REEL INFORMATION

QUADRANT ASSIGNMENTS FOR PIN 1 ORIENTATION IN TAPE

*All dimensions are nominal

Device	Package Type	Package Drawing	Pins	SPQ	Reel Diameter (mm)	Reel Width W1 (mm)	A0 (mm)	B0 (mm)	K0 (mm)	P1 (mm)	W (mm)	Pin1 Quadrant
TPS22960DCNR	SOT-23	DCN	8	3000	180.0	8.4	3.23	3.17	1.37	4.0	8.0	Q3
TPS22960RSER	UQFN	RSE	8	3000	180.0	8.4	1.7	1.7	0.7	4.0	8.0	Q2
TPS22960RSET	UQFN	RSE	8	250	180.0	8.4	1.6	1.6	0.66	4.0	8.0	Q2

TAPE AND REEL BOX DIMENSIONS

*All dimensions are nominal

Device	Package Type	Package Drawing	Pins	SPQ	Length (mm)	Width (mm)	Height (mm)
TPS22960DCNR	SOT-23	DCN	8	3000	183.0	183.0	20.0
TPS22960RSER	UQFN	RSE	8	3000	183.0	183.0	20.0
TPS22960RSET	UQFN	RSE	8	250	183.0	183.0	20.0

DCN (R-PDSO-G8)

PLASTIC SMALL-OUTLINE PACKAGE (DIE DOWN)

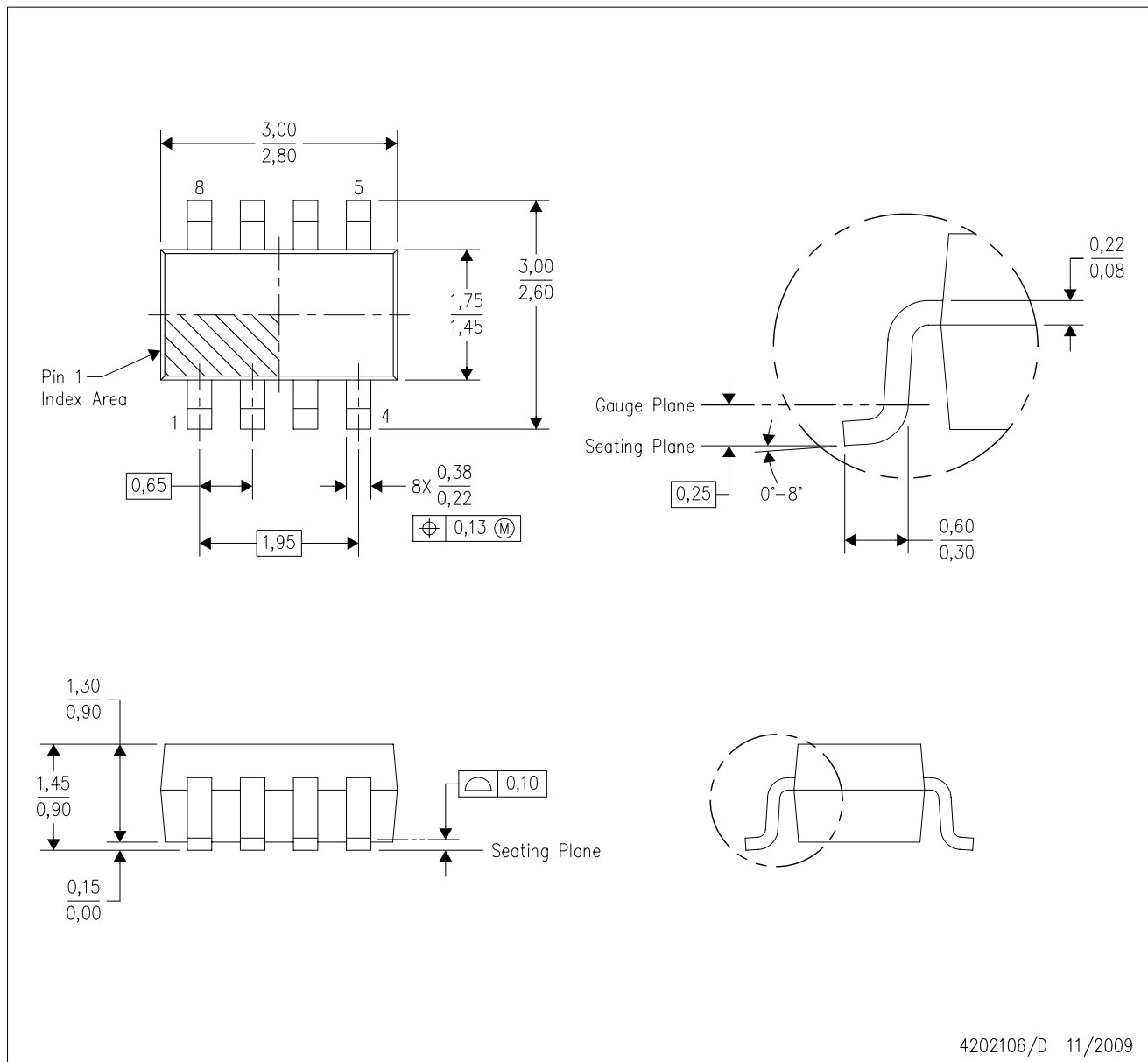

- NOTES:
- A. All linear dimensions are in millimeters.
 - B. This drawing is subject to change without notice.
 - C. Package outline exclusive of metal burr & dambar protrusion/intrusion.
 - D. Package outline inclusive of solder plating.
 - E. A visual index feature must be located within the Pin 1 index area.
 - F. Falls within JEDEC MO-178 Variation BA.
 - G. Body dimensions do not include flash or protrusion. Mold flash and protrusion shall not exceed 0.25 per side.

DCN (R-PDSO-G8)

PLASTIC SMALL-OUTLINE PACKAGE (DIE DOWN)

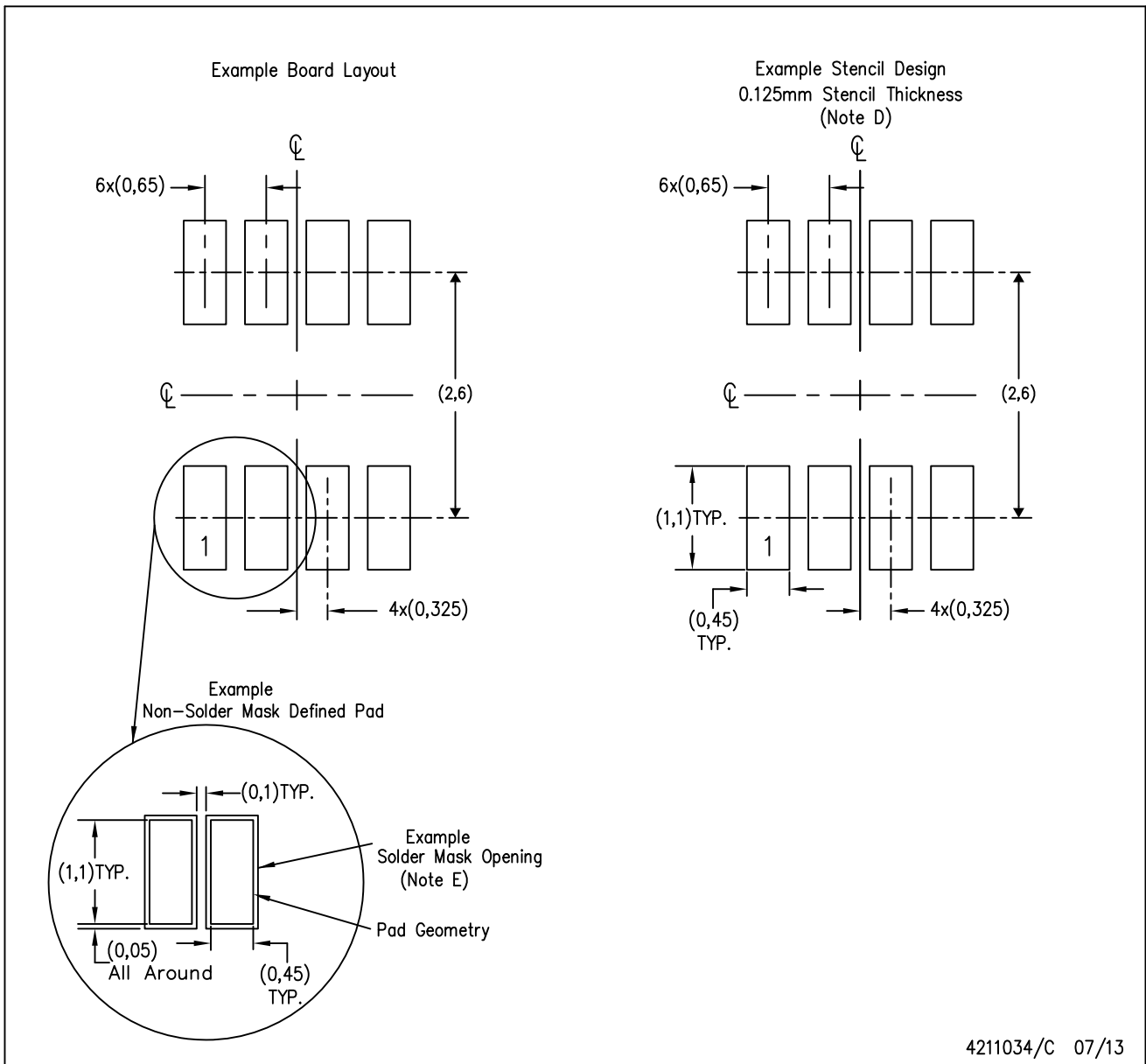

- NOTES:
- A. All linear dimensions are in millimeters.
 - B. This drawing is subject to change without notice.
 - C. Publication IPC-7351 is recommended for alternate designs.
 - D. Laser cutting apertures with trapezoidal walls and also rounding corners will offer better paste release. Customers should contact their board assembly site for stencil design recommendations. Refer to IPC-7525.
 - E. Customers should contact their board fabrication site for solder mask tolerances between and around signal pads.

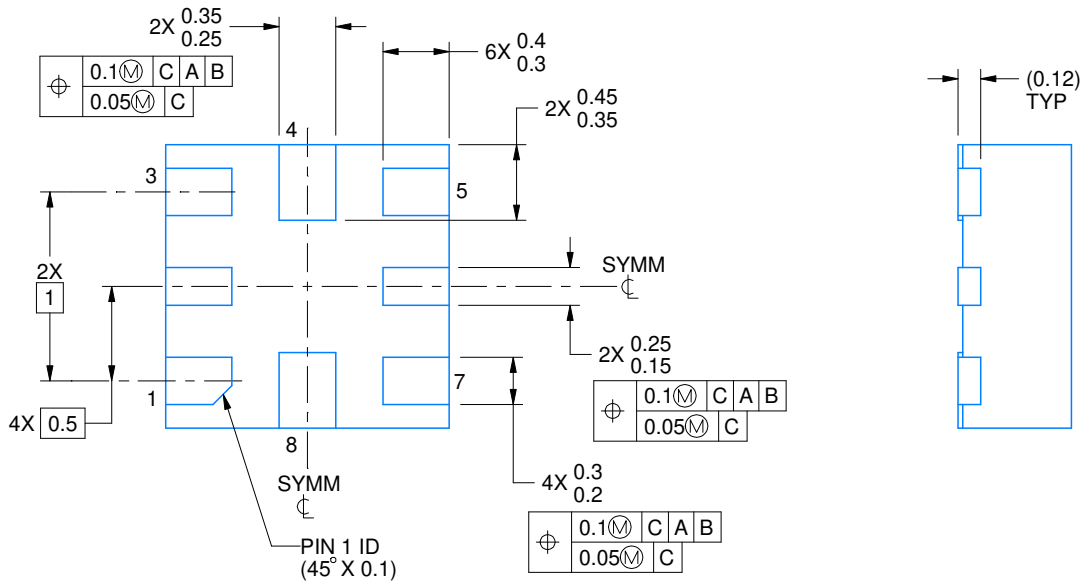
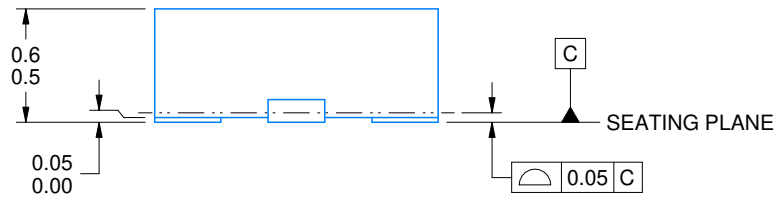
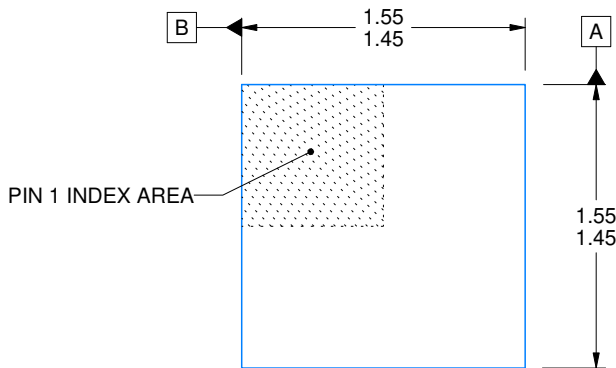
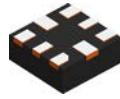

4220323/B 03/2018

NOTES:

1. All linear dimensions are in millimeters. Any dimensions in parenthesis are for reference only. Dimensioning and tolerancing per ASME Y14.5M.
2. This drawing is subject to change without notice.

EXAMPLE BOARD LAYOUT

RSE0008A

UQFN - 0.6 mm max height

PLASTIC QUAD FLATPACK - NO LEAD

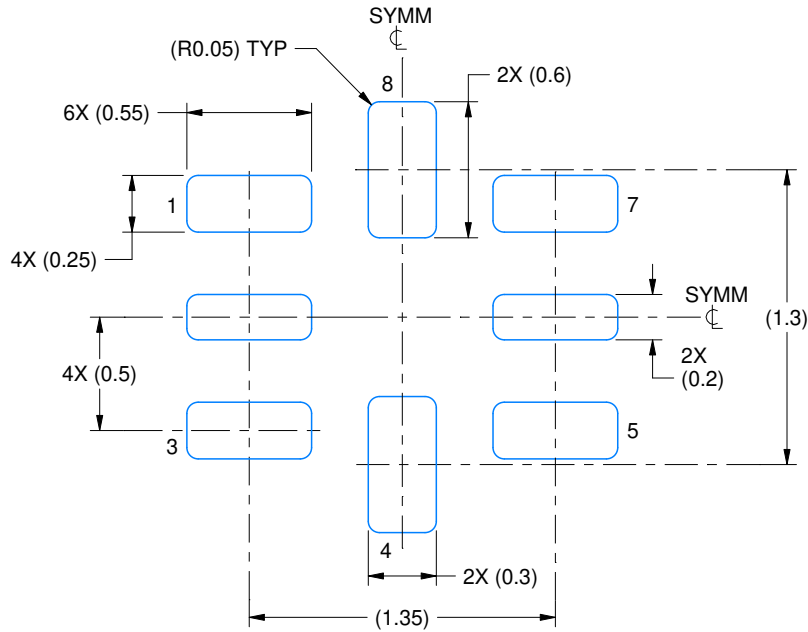

LAND PATTERN EXAMPLE
SCALE:30X

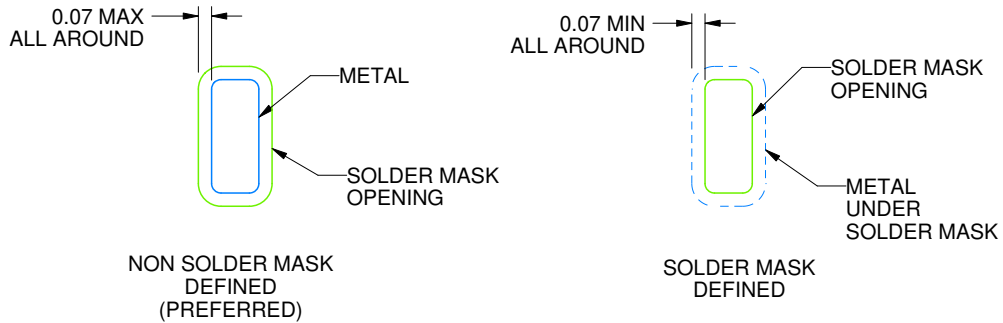

SOLDER MASK DETAILS
NOT TO SCALE

4220323/B 03/2018

NOTES: (continued)

3. For more information, see Texas Instruments literature number SLUA271 (www.ti.com/lit/slua271).

EXAMPLE STENCIL DESIGN

RSE0008A

UQFN - 0.6 mm max height

PLASTIC QUAD FLATPACK - NO LEAD

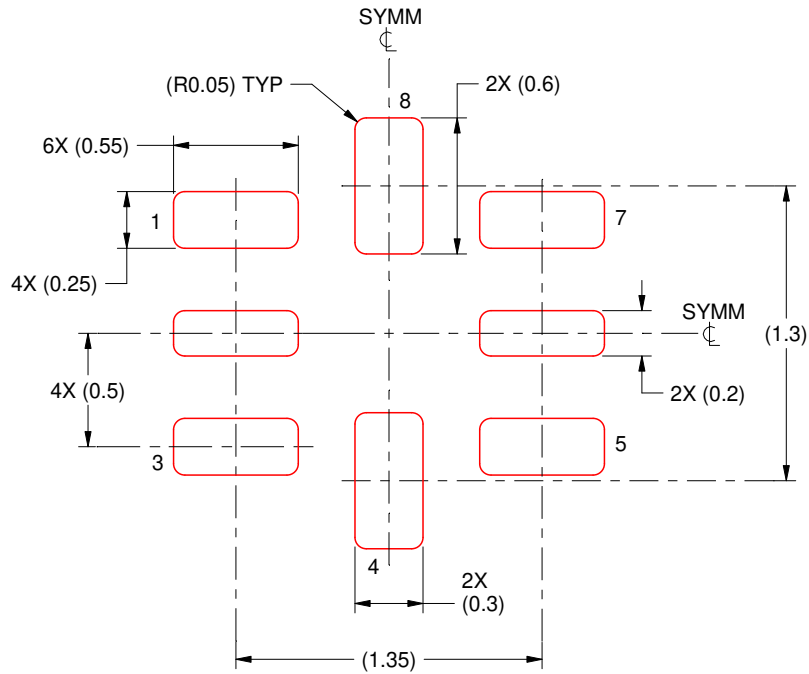

SOLDER PASTE EXAMPLE
BASED ON 0.1 mm THICKNESS
SCALE: 30X

4220323/B 03/2018

NOTES: (continued)

5. Laser cutting apertures with trapezoidal walls and rounded corners may offer better paste release. IPC-7525 may have alternate design recommendations.

IMPORTANT NOTICE AND DISCLAIMER

TI PROVIDES TECHNICAL AND RELIABILITY DATA (INCLUDING DATASHEETS), DESIGN RESOURCES (INCLUDING REFERENCE DESIGNS), APPLICATION OR OTHER DESIGN ADVICE, WEB TOOLS, SAFETY INFORMATION, AND OTHER RESOURCES "AS IS" AND WITH ALL FAULTS, AND DISCLAIMS ALL WARRANTIES, EXPRESS AND IMPLIED, INCLUDING WITHOUT LIMITATION ANY IMPLIED WARRANTIES OF MERCHANTABILITY, FITNESS FOR A PARTICULAR PURPOSE OR NON-INFRINGEMENT OF THIRD PARTY INTELLECTUAL PROPERTY RIGHTS.

These resources are intended for skilled developers designing with TI products. You are solely responsible for (1) selecting the appropriate TI products for your application, (2) designing, validating and testing your application, and (3) ensuring your application meets applicable standards, and any other safety, security, or other requirements. These resources are subject to change without notice. TI grants you permission to use these resources only for development of an application that uses the TI products described in the resource. Other reproduction and display of these resources is prohibited. No license is granted to any other TI intellectual property right or to any third party intellectual property right. TI disclaims responsibility for, and you will fully indemnify TI and its representatives against, any claims, damages, costs, losses, and liabilities arising out of your use of these resources.

TI's products are provided subject to TI's Terms of Sale (www.ti.com/legal/termsofsale.html) or other applicable terms available either on ti.com or provided in conjunction with such TI products. TI's provision of these resources does not expand or otherwise alter TI's applicable warranties or warranty disclaimers for TI products.

Mailing Address: Texas Instruments, Post Office Box 655303, Dallas, Texas 75265
Copyright © 2020, Texas Instruments Incorporated