

10 9 8 7 6 5 4 3 2 1

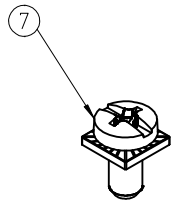

REF. -50 OPT. SCREW
(WHERE APPLICABLE)

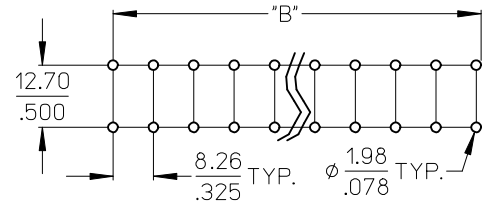
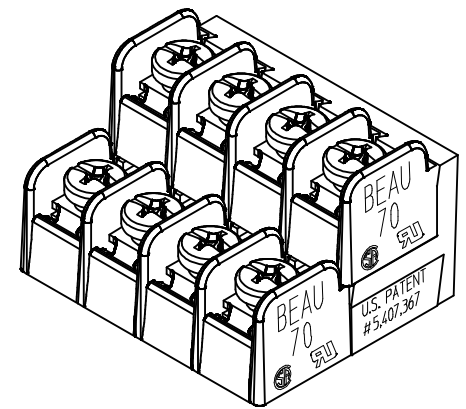
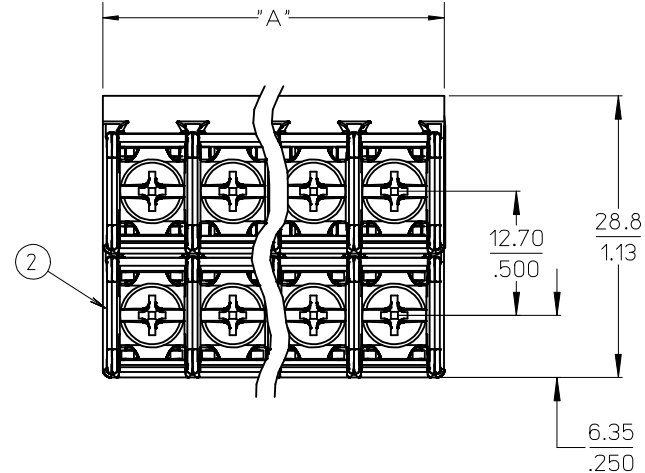

RECOMMENDED PTH PATTERN
SCALE 1:1

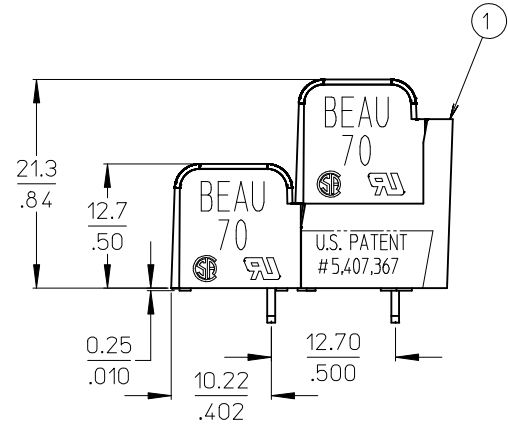
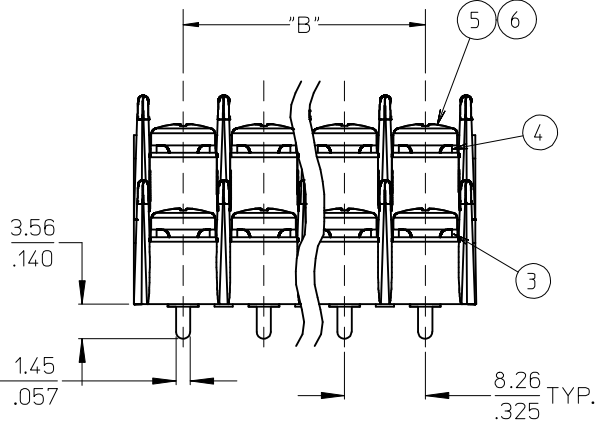

NOTES:

1. MATERIAL: SEE TABLE
2. FINISHES: SEE TABLE
3. PRODUCT SPECIFICATION: NOT REQUIRED
4. "XX" REFERS TO THE QUANTITY OF CIRCUITS.
5. - 58 OPTION - NO SCREWS, BARRIER ONLY.
6. ROHS COMPLIANT. (B)

7	XX	SCREW & WASHER #6-32, -50 OPT.	STEEL	ZN, CLEAR CHROMATE
6	XX	SCREW, #6-32X.250, PANHD, PHIL-SLOT, -49 OPT	BRASS	NICKEL PLATE
5	XX	SCREW, #6-32X.250, PANHD, PHIL-SLOT, STD.	STEEL	ZN, CLEAR CHROMATE
4	XX/2	TERMINAL, WW, EXTRA LONG	BRASS	TIN PLATE
3	XX/2	TERMINAL, PC	BRASS	TIN PLATE
2	2	INSULATOR, DOVE	POLYESTER (PBT)	BLACK
1	1	DOUBLE LEVEL BASE	POLYESTER (PBT)	BLACK
ITEM	QTY.	DESCRIPTION	MATERIAL	FINISH

UPDATE CHART PINS
EC NO: WNA2009-0702
DRAWN: JENC INAS 2009/05/26
CHKD: C YORK 2009/05/27
APPR: JMACNE ILL 2009/05/27

QUALITY SYMBOLS
▽=0
▽/0

GENERAL TOLERANCES (UNLESS SPECIFIED)	
	mm
	INCH
4 PLACES	± .005
3 PLACES	± .010
2 PLACES	± .013
1 PLACE	± .020
ANGULAR ± 2°	
DRAFT WHERE APPLICABLE MUST REMAIN WITHIN DIMENSIONS	

DIMENSION STYLE
MM/IN

DRAWN BY DATE
C. YORK 2005/03/15

CHECKED BY DATE
G. ROBERTSON 2005/03/17

APPROVED BY DATE
G. ROBERTSON 2005/03/18

MATERIAL NO.

SCALE 2:1

DESIGN UNITS INCH

THIRD ANGLE PROJECTION

TITLE
8.26 (.325"), DUAL LEVEL
BTS ASSEMBLY

MOLEX INCORPORATED

DOCUMENT NO. SD-38706-001

SHEET NO. 1 OF 2

THIS DRAWING CONTAINS INFORMATION THAT IS PROPRIETARY TO MOLEX INCORPORATED AND SHOULD NOT BE USED WITHOUT WRITTEN PERMISSION

10 9 8 7 6 5 4 3 2 1

(B) (B) (B) (B)

NO. OF CIRCUITS	DIM. "A"		DIM. "B"		ASSEMBLY MATERIAL NO. (STANDARD)	ASSEMBLY MATERIAL NO. (-49 OPT)	ASSEMBLY MATERIAL NO. (-50 OPT)	ASSEMBLY MATERIAL NO. (-58 OPT)
	mm	in	mm	in				
04	18.5	0.73	8.26	0.325	387068004	387068104	387068204	
06	26.8	1.05	16.51	0.650	387068006	387068106	387068206	
08	35.0	1.38	24.77	0.975	387068008	387068108	387068208	
10	43.3	1.70	33.02	1.300	387068010	387068110	387068210	387098218
12	51.5	2.03	41.28	1.625	387068012	387068112	387068212	387098237
14	59.8	2.35	49.53	1.950	387068014	387068114	387068214	
16	68.0	2.68	57.79	2.275	387068016	387068116	387068216	
18	76.3	3.00	66.04	2.600	387068018	387068118	387068218	
20	84.6	3.33	74.30	2.925	387068020	387068120	387068220	
22	92.8	3.65	82.55	3.250	387068022	387068122	387068222	
24	101.1	3.98	90.81	3.575	387068024	387068124	387068224	

SEE SHEET ONE EC NO: WNA2009-0702 DRWN: JENC INAS 2009/05/26 CHKD: CYORK 2009/05/27 APPR: JMACNE IL 2009/05/27	QUALITY SYMBOLS	GENERAL TOLERANCES (UNLESS SPECIFIED)		DIMENSION STYLE		SCALE	DESIGN UNITS	THIRD ANGLE PROJECTION	
	▼=0 ▽=0			MM/IN		2:1	INCH		
				mm	INCH	DRAWN BY DATE		TITLE 8.26 (.325"), DUAL LEVEL BTS ASSEMBLY	
				4 PLACES ± --- ± ---		C. YORK 2005/03/15			
				3 PLACES ± --- ± .005		CHECKED BY DATE			
		2 PLACES ± 0.13 ± .01		G. ROBERTSON 2005/03/17					
		1 PLACE ± .3 ± ---		APPROVED BY DATE		MOLEX INCORPORATED		DOCUMENT NO. SD-38706-001 SHEET NO. 2 OF 2	
		ANGULAR ± 2 °		G. ROBERTSON 2005/03/18					
		DRAFT WHERE APPLICABLE MUST REMAIN WITHIN DIMENSIONS		SEE CHART		THIS DRAWING CONTAINS INFORMATION THAT IS PROPRIETARY TO MOLEX INCORPORATED AND SHOULD NOT BE USED WITHOUT WRITTEN PERMISSION			

9 8 7 6 5 4 3 2 1