

*Phase leg  
Intelligent Power Module*

$V_{CES} = 1200V$   
 $I_C = 325A @ T_c = 80^\circ C$

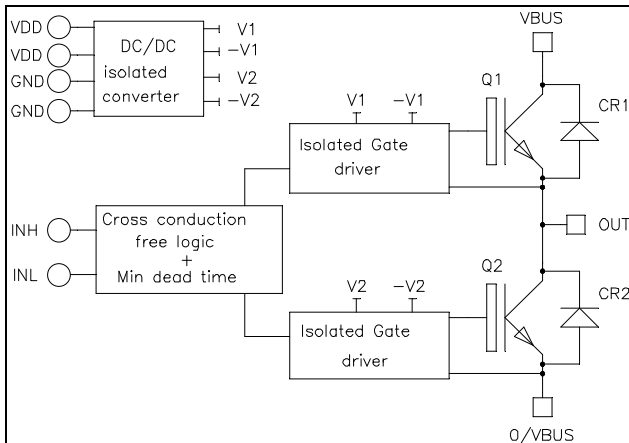

### Application

- Motor control
- Uninterruptible Power Supplies
- Switched Mode Power Supplies
- Amplifier

### Features

- **Trench + Field Stop IGBT 4 Technology**
  - Low voltage drop
  - Low leakage current
  - Low switching losses
  - Soft recovery parallel diodes
  - Low diode VF
  - RBSOA and SCSOA rated
- **Integrated Fail Safe IGBT Protection (Driver)**
  - Top Bottom input signals Interlock
  - Isolated DC/DC Converter

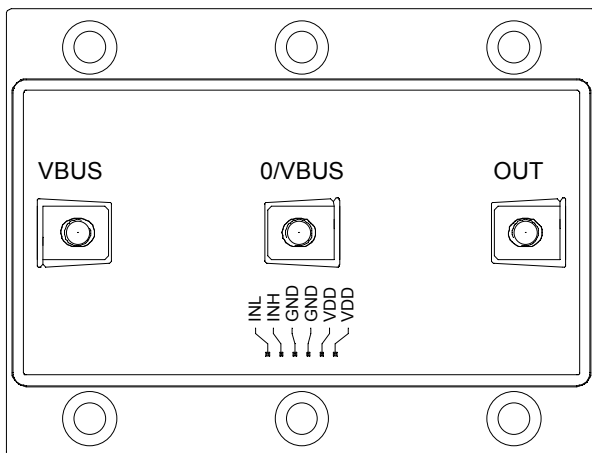

- Low stray inductance
- M5 power connectors
- High level of integration

### Benefits

- Outstanding performance at high frequency operation
- Stable temperature behavior
- Very rugged
- Direct mounting to heatsink (isolated package)
- Low junction to case thermal resistance
- Very high noise immunity (common mode rejection > 25kV/μs)
- Galvanic Isolation: 3750V for the optocoupler  
2500V for the transformer
- 5V logic level with Schmitt-trigger Input
- Single  $V_{DD}=5V$  supply required
- Secondary auxiliary power supplies internally generated (15V, -6V)
- Optocoupler qualified to AEC-Q100 test guidelines
- RoHS compliant

**CAUTION:** These Devices are sensitive to Electrostatic Discharge. Proper Handling Procedures Should Be Followed.  
See application note APT0502 on [www.microsemi.com](http://www.microsemi.com)

All ratings @  $T_j = 25^\circ\text{C}$  unless otherwise specified

### 1. Inverter Power Module

#### Absolute maximum ratings

Symbol	Parameter	Max ratings	Unit
$V_{CES}$	Collector - Emitter Breakdown Voltage	1200	V
$I_C$	Continuous Collector Current	$T_C = 25^\circ\text{C}$	420
		$T_C = 80^\circ\text{C}$	325
$I_{CM}$	Pulsed Collector Current	$T_C = 25^\circ\text{C}$	600
$P_D$	Maximum Power Dissipation	$T_C = 25^\circ\text{C}$	1500
RBSOA	Reverse Bias Safe Operating Area	$T_j = 150^\circ\text{C}$	600A @ 1150V

#### Electrical Characteristics

Symbol	Characteristic	Test Conditions	Min	Typ	Max	Unit
$I_{CES}$	Zero Gate Voltage Collector Current	$V_{GE} = 0\text{V}$ $V_{CE} = 1200\text{V}$	$T_j = 25^\circ\text{C}$		500	$\mu\text{A}$
			$T_j = 150^\circ\text{C}$		750	
$V_{CE(sat)}$	Collector Emitter Saturation Voltage	$V_{DD} = V_{IN} = 5\text{V}$ $I_C = 300\text{A}$	$T_j = 25^\circ\text{C}$	1.85	2.2	V
			$T_j = 150^\circ\text{C}$	2.2		

#### Dynamic Characteristics

Symbol	Characteristic	Test Conditions	Min	Typ	Max	Unit
$C_{ies}$	Input Capacitance	$V_{GE} = 0\text{V}$ $V_{CE} = 25\text{V}$ $f = 1\text{MHz}$		17.6		nF
$C_{oes}$	Output Capacitance			1.16		
$C_{res}$	Reverse Transfer Capacitance			0.94		
$T_r$	Rise Time	Inductive Switching ( $25^\circ\text{C}$ ) $V_{DD} = V_{IN} = 5\text{V}$ $V_{Bus} = 600\text{V}; I_C = 300\text{A}$		30		ns
$T_f$	Fall Time			70		
$T_r$	Rise Time	Inductive Switching ( $150^\circ\text{C}$ ) $V_{DD} = V_{IN} = 5\text{V}$ $V_{Bus} = 600\text{V}$ $I_C = 300\text{A}$		40		ns
$T_f$	Fall Time			80		
$E_{on}$	Turn-on Switching Energy	$V_{DD} = V_{IN} = 5\text{V}; V_{Bus} = 900\text{V}$ $t_p \leq 10\mu\text{s}; T_j = 150^\circ\text{C}$		34		mJ
$E_{off}$	Turn-off Switching Energy			29		
$I_{sc}$	Short Circuit data			1100		A
$R_{thJC}$	Junction to Case thermal resistance				0.1	$^\circ\text{C}/\text{W}$

**Reverse diode ratings and characteristics**

Symbol	Characteristic	Test Conditions		Min	Typ	Max	Unit
V <sub>RRM</sub>	Maximum Peak Repetitive Reverse Voltage			1200			V
I <sub>RM</sub>	Maximum Reverse Leakage Current	V <sub>R</sub> =1200V	T <sub>j</sub> = 25°C T <sub>j</sub> = 150°C			250 750	μA
I <sub>F</sub>	DC Forward Current		T <sub>c</sub> = 80°C		360		A
V <sub>F</sub>	Diode Forward Voltage	I <sub>F</sub> = 300A	T <sub>j</sub> = 25°C T <sub>j</sub> = 150°C		1.7 1.65	2.2	V
t <sub>rr</sub>	Reverse Recovery Time	I <sub>F</sub> = 300A V <sub>R</sub> = 600V di/dt = 7000A/μs	T <sub>j</sub> = 25°C T <sub>j</sub> = 150°C		155 300		ns
Q <sub>rr</sub>	Reverse Recovery Charge		T <sub>j</sub> = 25°C T <sub>j</sub> = 150°C		29 61		μC
E <sub>rr</sub>	Reverse Recovery Energy		T <sub>j</sub> = 25°C T <sub>j</sub> = 150°C		10.4 22		mJ
R <sub>thJC</sub>	Junction to Case Thermal Resistance						0.17

**2. Driver**
**Absolute maximum ratings**

Symbol	Parameter	Max ratings	Unit
V <sub>DD</sub>	Supply Voltage	5.5	V
V <sub>INi</sub>	Input signal voltage i=L, H	5.5	V
I <sub>VDDmax</sub>	Maximum Supply current	V <sub>INi</sub> = 0V, i = L & H	0.35
		V <sub>DD</sub> = 5V, V <sub>INH</sub> = V <sub>INL</sub> ; F <sub>out</sub> = 55kHz	2
f <sub>max</sub>	Maximum Switching Frequency	55	kHz

**Driver Electrical Characteristics**

Symbol	Characteristic	Test Conditions	Min	Typ	Max	Unit
V <sub>DD</sub>	Operating Supply Voltage		4.5	5	5.5	V
V <sub>INi(max)</sub>	Maximum Input Voltage	i = L, H	-0.5	5	5.5	V
V <sub>INi(th+)</sub>	Positive Going Threshold Voltage			3.2		
V <sub>INi(th-)</sub>	Negative Going Threshold Voltage			1		
R <sub>INi</sub>	Input Resistance *				1	kΩ
T <sub>d(on)</sub>	Turn On delay time	Driver + IGBT		1100 <sup>❶</sup>		ns
D <sub>T</sub>	Built in dead time			600		
T <sub>d(off)</sub>	Turn Off delay time	Driver + IGBT		750		
PWD	Pulse Width Distortion				300	ns
PDD	Propagation Delay Difference between any two driver	T <sub>d(on)</sub> - T <sub>d(off)</sub>	-350		350	
V <sub>ISOL</sub>	Primary to Secondary Isolation		2500			V <sub>RMS</sub>

\* Low impedance guarantees good noise immunity.

❶ Including built in dead time.

### 3. Package characteristics

Symbol	Characteristic	Min	Typ	Max	Unit	
V <sub>ISOL</sub>	RMS Isolation Voltage, any terminal to case t =1 min, 50/60Hz	4000			V	
T <sub>J</sub>	Operating junction temperature range	-40		150	°C	
T <sub>OP</sub>	Operating Ambient Temperature	-40		85		
T <sub>STG</sub>	Storage Temperature Range	-40		100		
T <sub>C</sub>	Operating Case Temperature	-40		100		
Torque	Mounting torque	To heatsink	M5	2	4.7	N.m
		For terminals	M5	2	4	
Wt	Package Weight		550		g	

### 4. LP8 Package outline (dimensions in mm)

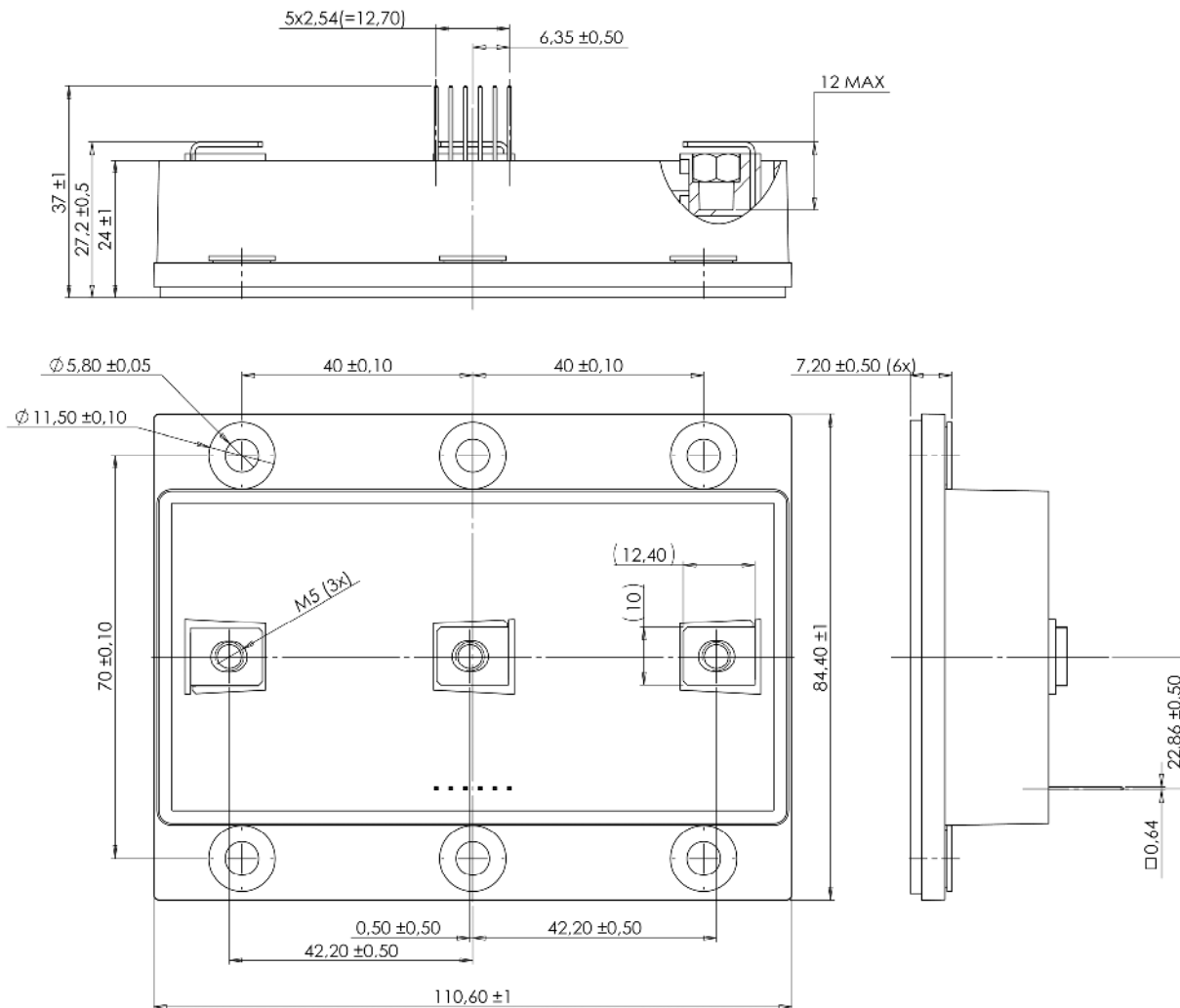

## Typical IGBT Performance Curve

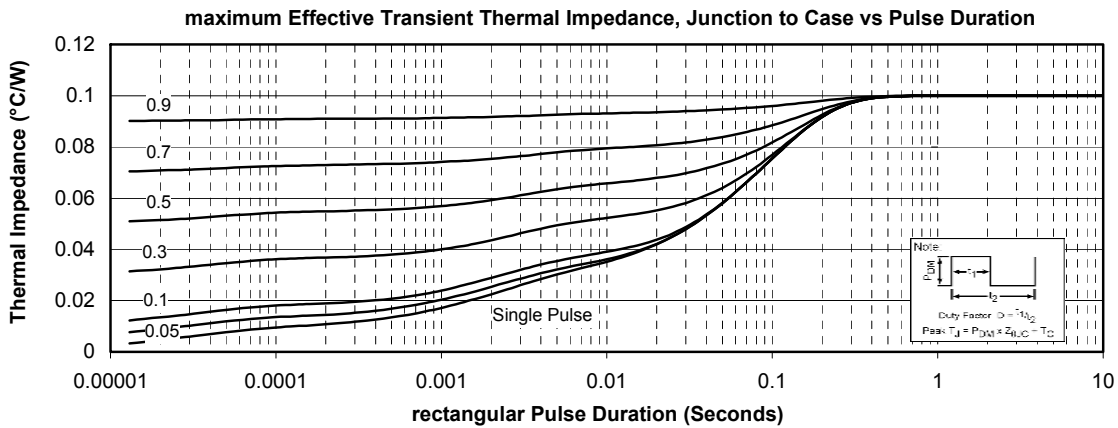
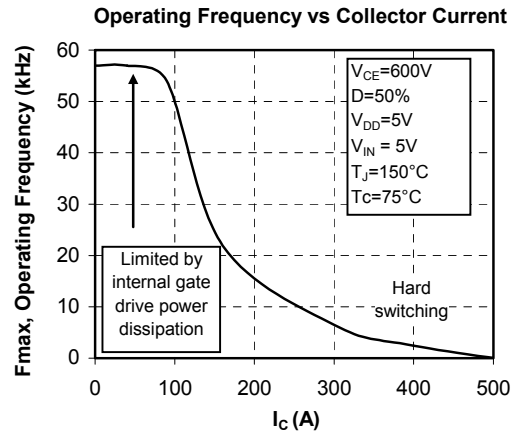
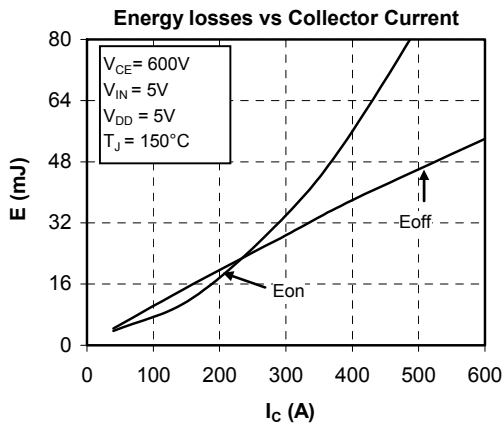
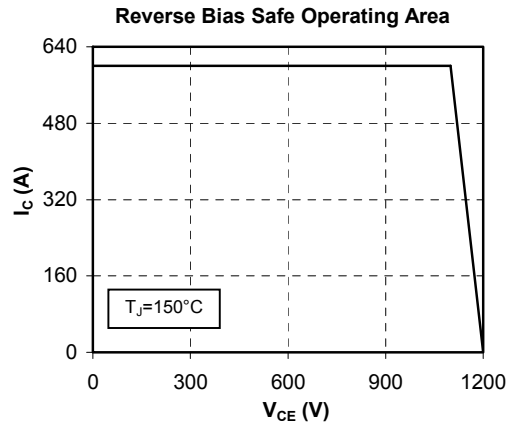
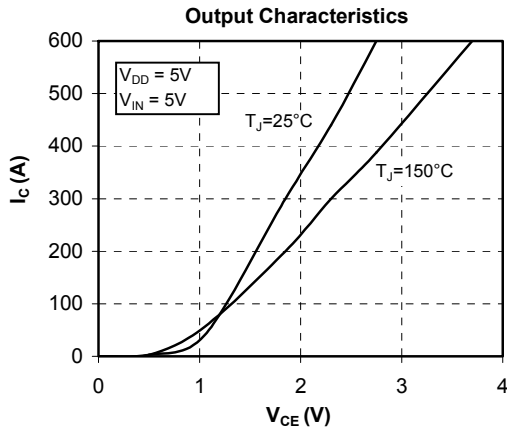

## Typical diode Performance Curve

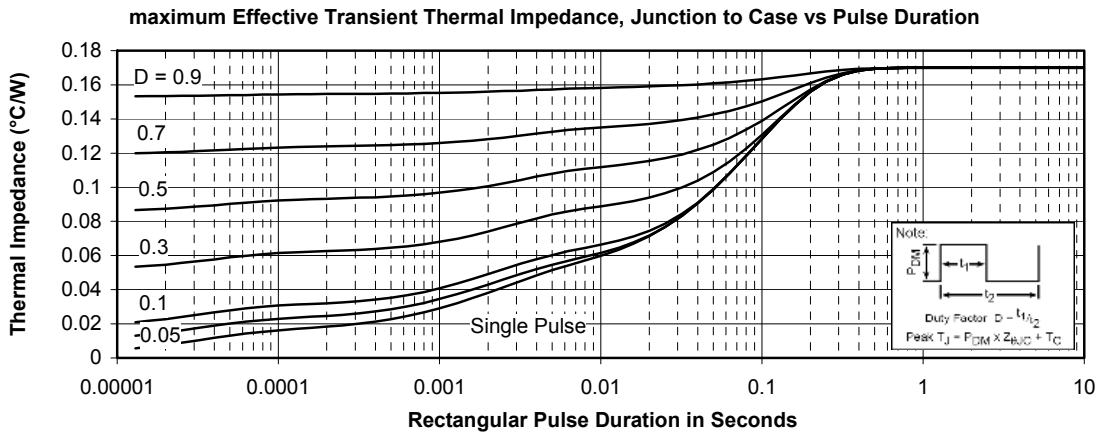
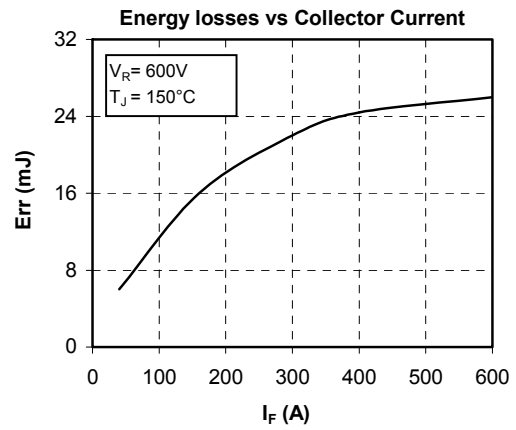
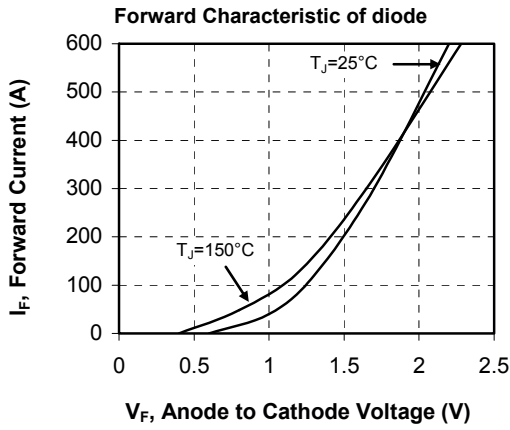

DISCLAIMER

The information contained in the document (unless it is publicly available on the Web without access restrictions) is PROPRIETARY AND CONFIDENTIAL information of Microsemi and cannot be copied, published, uploaded, posted, transmitted, distributed or disclosed or used without the express duly signed written consent of Microsemi. If the recipient of this document has entered into a disclosure agreement with Microsemi, then the terms of such Agreement will also apply. This document and the information contained herein may not be modified, by any person other than authorized personnel of Microsemi. No license under any patent, copyright, trade secret or other intellectual property right is granted to or conferred upon you by disclosure or delivery of the information, either expressly, by implication, inducement, estoppels or otherwise. Any license under such intellectual property rights must be approved by Microsemi in writing signed by an officer of Microsemi.

Microsemi reserves the right to change the configuration, functionality and performance of its products at anytime without any notice. This product has been subject to limited testing and should not be used in conjunction with life-support or other mission-critical equipment or applications. Microsemi assumes no liability whatsoever, and Microsemi disclaims any express or implied warranty, relating to sale and/or use of Microsemi products including liability or warranties relating to fitness for a particular purpose, merchantability, or infringement of any patent, copyright or other intellectual property right. Any performance specifications believed to be reliable but are not verified and customer or user must conduct and complete all performance and other testing of this product as well as any user or customers final application. User or customer shall not rely on any data and performance specifications or parameters provided by Microsemi. It is the customer's and user's responsibility to independently determine suitability of any Microsemi product and to test and verify the same. The information contained herein is provided "AS IS, WHERE IS" and with all faults, and the entire risk associated with such information is entirely with the User. Microsemi specifically disclaims any liability of any kind including for consequential, incidental and punitive damages as well as lost profit. The product is subject to other terms and conditions which can be located on the web at <http://www.microsemi.com/legal/tnc.asp>

Life Support Application

Seller's Products are not designed, intended, or authorized for use as components in systems intended for space, aviation, surgical implant into the body, in other applications intended to support or sustain life, or for any other application in which the failure of the Seller's Product could create a situation where personal injury, death or property damage or loss may occur (collectively "Life Support Applications").

Buyer agrees not to use Products in any Life Support Applications and to the extent it does it shall conduct extensive testing of the Product in such applications and further agrees to indemnify and hold Seller, and its officers, employees, subsidiaries, affiliates, agents, sales representatives and distributors harmless against all claims, costs, damages and expenses, and attorneys' fees and costs arising, directly or indirectly, out of any claims of personal injury, death, damage or otherwise associated with the use of the goods in Life Support Applications, even if such claim includes allegations that Seller was negligent regarding the design or manufacture of the goods.

Buyer must notify Seller in writing before using Seller's Products in Life Support Applications. Seller will study with Buyer alternative solutions to meet Buyer application specification based on Sellers sales conditions applicable for the new proposed specific part.