



Please note that Cypress is an Infineon Technologies Company.

The document following this cover page is marked as “Cypress” document as this is the company that originally developed the product. Please note that Infineon will continue to offer the product to new and existing customers as part of the Infineon product portfolio.

Continuity of document content

The fact that Infineon offers the following product as part of the Infineon product portfolio does not lead to any changes to this document. Future revisions will occur when appropriate, and any changes will be set out on the document history page.

Continuity of ordering part numbers

Infineon continues to support existing part numbers. Please continue to use the ordering part numbers listed in the datasheet for ordering.

USB-Serial Dual Channel SPI Bridge

Features

- USB 2.0 compliant, Full-Speed (12 Mbps)
 - Support for communication driver class (CDC), personal health care device class (PHDC), and vendor device class
 - Battery charger detection (BCD) compliant with USB Battery Charging Specification Rev 1.2 (Peripheral Detect only)
 - Integrated USB termination resistors
- Two-channel configurable SPI interfaces
 - Data rate up to 3 MHz for SPI master and 1 MHz for SPI slave
 - Data width: 4 bits to 16 bits
 - 256 bytes for each transmit and receive buffer per channel
 - Supports Motorola, TI, and National SPI modes
- Two-channel configurable SPI interfaces
 - Data rate up to 3 MHz for SPI master and 1 MHz for SPI slave
 - Data width: 4 bits to 16 bits
 - 256 bytes for each transmit and receive buffer per channel
 - Supports Motorola, TI, and National SPI modes
- General-purpose input/output (GPIO) pins: 8
- Configuration utility (Windows) to configure the following:
 - Vendor ID (VID), Product ID (PID), and Product and Manufacturer descriptors
 - SPI
 - Charger detection
 - GPIO
- Driver support for VCOM and DLL
 - Windows 10: 32- and 64-bit versions
 - Windows 8.1: 32- and 64-bit versions
 - Windows 8: 32- and 64-bit versions
 - Windows 7: 32- and 64-bit versions
 - Windows Vista: 32- and 64-bit versions
 - Windows XP: 32- and 64-bit versions
 - Mac OS-X: 10.6, and later versions
 - Linux: Kernel version 2.6.35 onwards
- Clocking: Integrated 48-MHz clock oscillator
- Supports bus-/self-powered configurations
- USB suspend mode for low power
- Operating voltage: 1.71 to 5.5 V
- Operating temperature
 - Commercial: 0 °C to 70 °C
 - Industrial: -40 °C to 85 °C
- ESD protection: 2.2 kV HBM
- RoHS compliant package
 - 32-pin QFN (5 × 5 × 1 mm, 0.5 mm pitch)
- Ordering part number
 - CY7C65214D

Applications

- Medical/healthcare devices
- Point-of-Sale (POS) terminals
- Test and measurement system
- Gaming systems
- Set-top box PC-USB interface
- Industrial
- Networking
- Enabling USB connectivity in legacy peripherals

USB Compliant

The USB Dual-Channel SPI Bridge Controller is fully compliant with USB2.0 specification and Battery Charging Specification v1.2.



USB Serial Bridge Controller Family

USB Serial bridge Controllers are a family of configurable products for most common applications requiring no firmware changes. Configuration utility is provided to Configure USB-VID, USB-PID, USB Product and Manufacturer Descriptors. The same configuration utility can be used to configure UART, I²C, SPI, Battery Charger Detection, GPIOs, Power mode, and so on.

Figure 1. USB Serial Bridge Controller Family

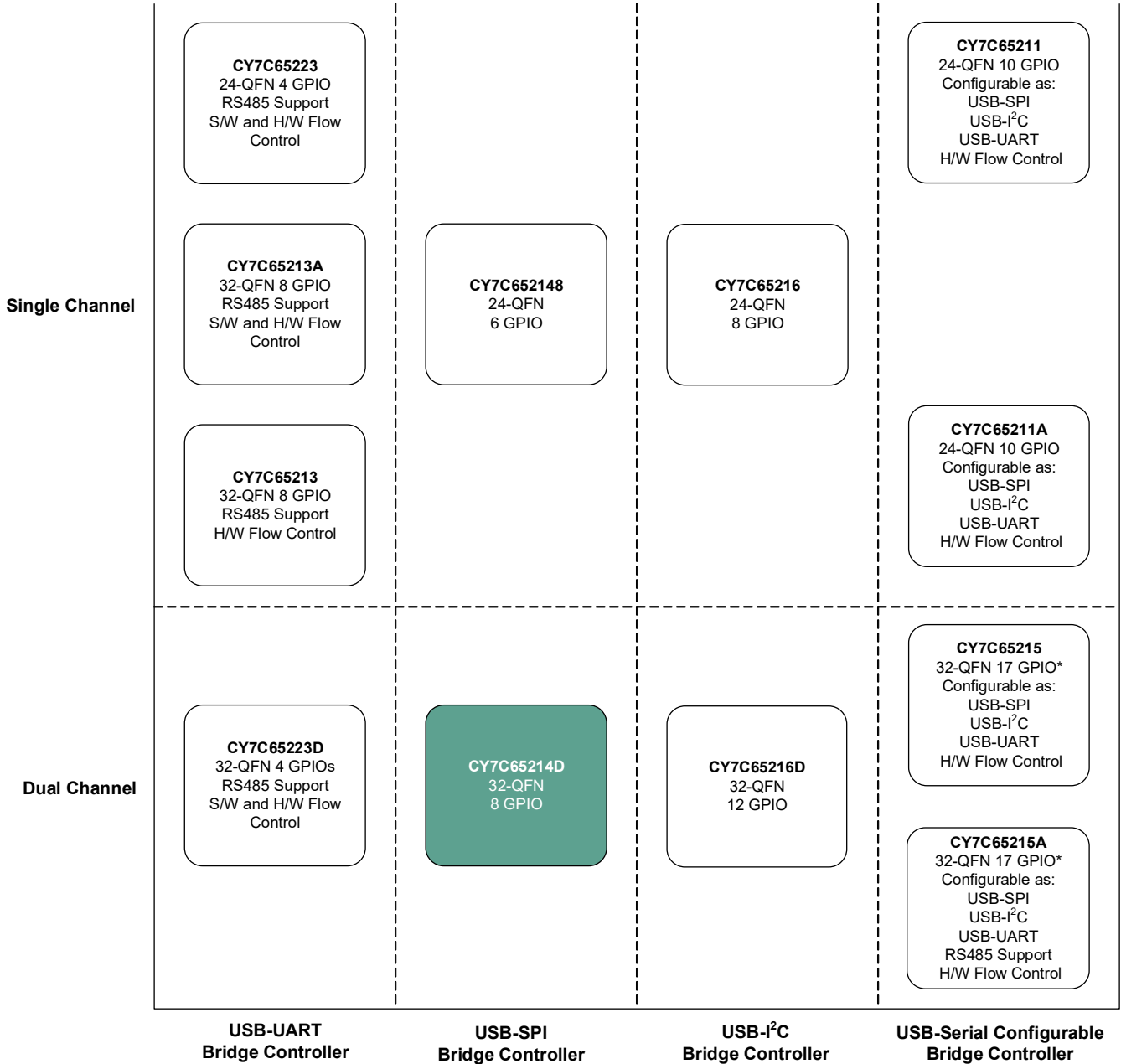

Table 1. USB Serial Family Feature Comparison

MPN	# of Channels	GPIO	USB-UART				USB-SPI		USB-I ² C
			RS485 Support	Software Flow Control	Hardware Flow Control	UART Pins**	SPI Serial Data Width (bit)	SPI Master/Slave	I ² C Master/Slave
CY7C65213	1	8	N	N	Y	8	–	–	–
CY7C65213A	1	8	Y	N	Y	8	–	–	–
CY7C65223	1	4	Y	Y	Y	2 / 4 / 6	–	–	–
CY7C65223D	2	4	Y	Y	Y	2 / 4 / 6 / 8	–	–	–
CY7C652148	1	6	–	–	–	–	4-16 bits	Master/Slave	–
CY7C65214D	2	8	–	–	–	–	4-16 bits	Master/Slave	–
CY7C65216	1	8	–	–	–	–	–	–	Master/Slave
CY7C65216D	2	12	–	–	–	–	–	–	Master/Slave
CY7C65211	1	10*	N	N	Y	2 / 4 / 6	4-16 bits	Master/Slave	Master/Slave
CY7C65211A	1	10*	Y	N	Y	2 / 4 / 6	4-16 bits	Master/Slave	Master/Slave
CY7C65215	2	17*	N	N	Y	2 / 4 / 6	4-16 bits	Master/Slave	Master/Slave
CY7C65215A	2	17*	Y	N	Y	2 / 4 / 6 / 8	4-16 bits	Master/Slave	Master/Slave

Legend

* Represents the total GPIO count offered by the part. This count can dynamically change based on UART / SPI / I²C pin configuration.

** UART Pins

**UART Pins	UART Signal
2	RxD and TxD
4	RxD, TxD, RTS#, CTS#
6	RxD, TxD, RTS#, CTS#, DTR#, DSR#
8	RxD, TxD, RTS#, CTS#, DTR#, DSR#, DCD#, RI#

Table 2. Default Serial Channel Configuration

MPN	# of Channels	GPIO	USB Protocol	USB- UART		USB-SPI	USB-I ² C
				Is RS485 Enabled	UART Pins	SPI Master/ Slave	I ² C Master/ Slave
CY7C65213	1	4	CDC**	N	8	–	–
CY7C65213A	1	4	CDC**	N	8	–	–
CY7C65223	1	4	CDC**	Y	4	–	–
CY7C65223D	2	4	CDC**	Y	4	–	–
CY7C652148	1	6	Vendor***	–	–	Master	–
CY7C65214D	2	8	Vendor***	–	–	Master	–
CY7C65216	1	8	Vendor***	–	–	–	Slave
CY7C65216D	2	12	Vendor***	–	–	–	Master
CY7C65211	1	3	CDC**	N	6	–	–
CY7C65211A	1	3	CDC**	N	6	–	–
CY7C65215	2	4	CDC**	N	6	–	–
CY7C65215A	2	4	CDC**	N	6	–	–

** USB CDC Protocol allows the USB host Operating System to detect the device as Virtual COM Port Device.

*** USB Vendor Protocol allows the USB host operating system to detect the device as general USB device. This device is accessible using Cypress Application Library.

More Information

Cypress provides a wealth of data at www.cypress.com to help you to select the right device for your design, and to help you to quickly and effectively integrate the device into your design. For a comprehensive list of resources, see the document [USB-Serial Bridge Controller Product Overview](#).

- Overview: [USB Portfolio](#), [USB Roadmap](#)
- USB 2.0 Product Selectors: [USB-Serial Bridge Controller](#), [USB to UART Controller \(Gen I\)](#)
- Knowledge Base Articles: Cypress offers a large number of USB knowledge base articles covering a broad range of topics, from basic to advanced level. Recommended knowledge base articles for getting started with USB-Serial Bridge Controller are:
 - [KBA85909](#) – Key Features of the Cypress® USB-Serial Bridge Controller
 - [KBA85920](#) – USB-UART and USB-Serial
 - [KBA85921](#) – Replacing FT232R with CY7C65213 USB-UART LP Bridge Controller
 - [KBA85913](#) – Voltage supply range for USB-Serial
 - [KBA89355](#) – USB-Serial: Cypress Default VID and PID
 - [KBA92641](#) – USB-Serial Bridge Controller Managing I/Os using API
 - [KBA92442](#) – Non-Standard Baud Rates in USB-Serial Bridge Controllers
 - [KBA91366](#) – Binding a USB-Serial Device to a Microsoft® CDC Driver
 - [KBA92551](#) – Testing a USB-Serial Bridge Controller Configured as USB-UART with Linux®
 - [KBA91299](#) – Interfacing an External I²C Device with the CYUSBS234/236 DVK

For a complete list of knowledge base articles, click [here](#).

- Code Examples: [USB Full-Speed](#)
- Development Kits:
 - [CYUSBS232](#), Cypress USB-UART LP Reference Design Kit
 - [CYUSBS234](#), Cypress USB-Serial (Single Channel) Development Kit
 - [CYUSBS236](#), Cypress USB-Serial (Dual Channel) Development Kit
- Models: [IBIS](#)

Block Diagram

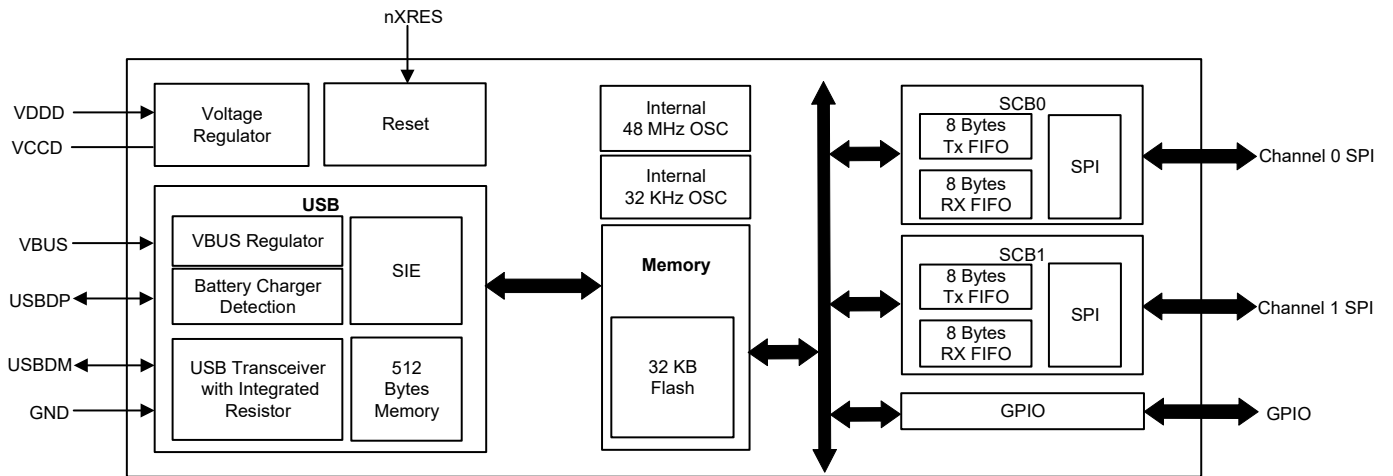

Contents

Functional Overview	8	USB Power Configurations	21
USB and Charger Detect	8	USB Bus-Powered Configuration	21
Serial Communication	8	Self-Powered Configuration	22
GPIO Interface	8	USB Bus Powered with Variable I/O Voltage	23
Default Configuration	8	Application Examples	24
Memory	8	USB-to-Dual SPI Bridge with Battery-Charge	
System Resources	8	Detection	24
Suspend and Resume	9	USB to Dual Channel (SPI) Bridge	26
WAKEUP	9	Ordering Information	31
Software	9	Ordering Code Definitions	31
Internal Flash Configuration	10	Package Information	32
Electrical Specifications	11	Acronyms	33
Absolute Maximum Ratings	11	Document Conventions	33
Operating Conditions	11	Units of Measure	33
Device Level Specifications	11	Document History Page	34
GPIO	12	Sales, Solutions, and Legal Information	35
nXRES	13	Worldwide Sales and Design Support	35
SPI Specifications	14	Products	35
Flash Memory Specifications	16	PSoC® Solutions	35
Pin Description	17	Cypress Developer Community	35
		Technical Support	35

Functional Overview

The CY7C65214D is a Full-Speed USB controller that enables seamless PC connectivity for peripherals with dual-channel SPI serial interface. CY7C65214D also integrates BCD, which is compliant with the USB Battery Charging Specification Rev. 1.2. It integrates a voltage regulator, oscillator, and flash memory for storing configuration parameters, offering a cost-effective solution. CY7C65214D supports bus-powered and self-powered modes, and enables efficient system power management with suspend and remote wake-up signals. It is available in a 32-pin QFN package.

USB and Charger Detect

USB

CY7C65214D has a built-in USB 2.0 Full-Speed transceiver. The transceiver incorporates the internal USB series termination resistors on the USB data lines and a 1.5-k Ω pull-up resistor on USB DP.

Table 3. Maximum Speed supported on both SCBs

No.	Configuration	SCB0 Maximum Speed	SCB1 Maximum Speed
1	SCB0 = SPI Master, SCB1 = Disabled	3M (Both TX and RX)	NA
2	SCB0 = SPI Slave, SCB1 = Disabled	1M (Both TX and RX)	NA
3	SCB0 = SPI, SCB1 = SPI	1M (Both TX and RX)	1M (Both TX and RX)

SPI Interface

The SPI interface supports SPI Master and SPI Slave. This interface supports the Motorola, TI, and National Microwire protocols. The maximum frequency of operation is 3 MHz in SPI master mode and 1 MHz in SPI slave mode. It can support transaction sizes ranging from 4 bits to 16 bits in length, SPI slave supports 4 bits to 8 bits and 12 bits to 16 bits data width at 1 MHz operation. Whereas, it supports 9 bits, 10 bits and 11 bits data width operation at 500 kHz operation (for more details, refer to [USB to Dual Channel \(SPI\) Bridge on page 26](#)).

GPIO Interface

CY7C65214D has eight GPIOs. The configuration utility allows configuration of the GPIO pins. The configurable options are as follows:

- TRISTATE: GPIO tristated through Config utility
- DRIVE 1: Output static 1
- DRIVE 0: Output static 0
- POWER#: Power control for bus power designs
- TXLED#: Drives LED during USB transmit
- RXLED#: Drives LED during USB receive
- TX or RX LED#: Drives LED during USB transmit or receive
GPIO can be configured to drive LED at 8-mA drive strength.
- BCD0/BCD1: Two-pin output to indicate the type of USB charger
- BUSDETECT: Connects VBUS pin for USB host detection

Default Configuration

CY7C65214D is configured as Dual SPI Master device.

Charger Detection

CY7C65214D supports BCD for Peripheral Detect only and complies with the USB Battery Charging Specification Rev. 1.2. It supports the following charging ports:

- Standard Downstream Port (SDP): allows the system to draw up to 500 mA current from the host
- Charging Downstream Port (CDP): allows the system to draw up to 1.5 A current from the host
- Dedicated Charging Port (DCP): allows the system to draw up to 1.5 A of current from the wall charger

Serial Communication

CY7C65214D has two serial communication blocks (SCBs). Each SCB can implement an SPI interface. A 256-byte buffer is available in both the TX and RX lines.

[Table 3](#) shows maximum speed supported on both SCBs when they are configured as SPI.

Memory

CY7C65214D has a 512-byte flash. The flash is used to store the USB parameters such as VID/PID, serial number, Product, and Manufacturer Descriptors, which can be programmed by the configuration utility.

System Resources

Power System

CY7C65214D supports the USB Suspend mode to control power usage. CY7C65214D operates in bus-powered or self-powered modes over a range of 3.15 to 5.5 V.

Clock System

CY7C65214D has a fully integrated clock and does not require any external components. The clock system is responsible for providing clocks to all subsystems.

Internal 48-MHz Oscillator

The internal 48-MHz oscillator is the primary source of internal clocking in CY7C65214D.

Internal 32-kHz Oscillator

The internal 32-kHz oscillator is primarily used to generate clocks for peripheral operation in the USB Suspend mode.

Reset

The reset block ensures reliable power-on reset and brings the device back to the default known state. The nXRES (active low) pin can be used by external devices to reset the CY7C65214D.

Suspend and Resume

The CY7C65214D device asserts the SUSPEND pin when the USB bus enters the suspend state. This helps in meeting the stringent suspend current requirement of the USB 2.0 specification, while using the device in bus-powered mode. The device will resume from the suspend state under any of the following conditions:

1. Any activity is detected on the USB bus
2. The WAKEUP pin is asserted to generate remote wakeup to the host

WAKEUP

The WAKEUP pin is used to generate a remote wakeup signal on the USB bus. The remote wakeup signal is sent only if the host enables this feature through the SET_FEATURE request. The device communicates support for the remote wakeup to the host through the configuration descriptor during the USB enumeration process. The CY7C65214D device allows enabling/disabling and polarity of the remote wakeup feature through the configuration utility.

Software

Cypress delivers a complete set of software drivers and the configuration utility to enable product configuration during system development.

Drivers for Linux Operating Systems

Cypress provides a User Mode USB driver library (*libcyusb-serial.so*) that abstracts vendor commands for the SPI interface and provides a simplified API interface to the user applications. This library makes use of the standard open source libUSB library to enable the USB communication. The Cypress serial library supports the USB plug-and-play feature using the Linux 'udev' mechanism.

CY7C65214D USB device will bind to the native Linux Kernel driver. User can use cypress provided application library for accessing the USB-SPI device and thereby perform SPI transactions.

Drivers for Mac OSx

Cypress delivers a dynamically linked shared library (CyUSBSerial.dylib) based on libUSB, which enables communication to the CY7C65214D device.

CY7C65214D USB device binds to native MAC OSx driver. There is no special driver is required.

Drivers for Windows Operating Systems

For Windows operating systems (XP, Vista, Win7, Win8, Win8.1, and Win10), Cypress delivers a User Mode dynamically linked library—CyUSBSerial DLL—that abstracts vendor-specific interface of CY7C65214D devices and provides convenient APIs to the user. It provides interface APIs for vendor-specific SPI and class-specific APIs for PHDC.

USB-SPI Bridge Controller works with Cypress provided USB vendor class driver. The Cypress Windows drivers are MS logo certified drivers.

These drivers will bind to device through WU (Windows Update) services.

Cypress drivers also support Windows plug-and-play and power management and USB Remote Wake-up.

Device Configuration Utility (Windows Only)

A Windows-based configuration utility is available to configure various device initialization parameters. This graphical user application provides an interactive interface to define the various boot parameters stored in the device flash.

This utility allows the user to save a user-selected configuration to text or xml formats. It also allows users to load a selected configuration from text or xml formats. The configuration utility allows the following operations:

- View current device configuration
- Select and configure SPI, battery charging, and GPIOs
- Configure USB VID, PID, and string descriptors
- Save or Load configuration

You can download the free configuration utility and drivers from www.cypress.com.

Internal Flash Configuration

The internal flash memory can be used to store the configuration parameters shown in the following table. A free configuration utility is provided to configure the parameters listed in the table to meet application specific requirements over USB interface. The configuration utility can be downloaded from www.cypress.com/usbserial.

Table 4. Internal Flash Configuration for both CY7C65214D

Parameter	Default Value	Description
USB Configuration		
USB Vendor ID (VID)	0x04B4	Default Cypress VID. Can be configured to customer VID
USB Product ID (PID)	0x0005	Default Cypress PID. Can be configured to customer PID
Manufacturer string	Cypress	Can be configured with any string up to 64 characters
Product string	USB-Serial (Dual Channel)	Can be configured with any string up to 64 characters
Serial string		Can be configured with any string up to 64 characters
Power mode	Bus powered	Can be configured to bus-powered or self-powered mode
Max current draw	100 mA	Can be configured to any value from 0 to 500 mA. Based on this, the configuration descriptor will be updated.
Remote wakeup	Enabled	Can be disabled. Remote wakeup is initiated by asserting WAKEUP pin
USB interface protocol	Vendor	Can be configured to function in CDC, PHDC, or Cypress vendor class
BCD	Disabled	Charger detect is disabled by default. When BCD is enabled, three of the GPIOs must be configured for BCD

Electrical Specifications

Absolute Maximum Ratings

Exceeding maximum ratings ^[1] may shorten the useful life of the device.

Storage temperature -55 °C to +100 °C

Ambient temperature with power supplied (Industrial) -40 °C to +85 °C

Supply voltage to ground potential

V_{DDD} 6.0 V

V_{BUS} 6.0 V

V_{CCD} 1.95 V

V_{GPIO} V_{DDD} + 0.5 V

Static discharge voltage ESD protection levels:

■ 2.2-kV HBM per JESD22-A114

Latch-up current 140 mA

Current per GPIO 25 mA

Operating Conditions

T_A (ambient temperature under bias)

Industrial -40 °C to +85 °C

V_{BUS} supply voltage 3.15 V to 5.25 V

V_{DDD} supply voltage 1.71 V to 5.50 V

V_{CCD} supply voltage 1.71 V to 1.89 V

Device Level Specifications

All specifications are valid for -40 °C ≤ T_A ≤ 85 °C, T_J ≤ 100 °C, and 1.71 V to 5.50 V, except where noted.

Table 5. DC Specifications

Parameter	Description	Min	Typ	Max	Units	Details/Conditions
V _{BUS}	V _{BUS} supply voltage	3.15	3.30	3.45	V	Set and configure correct voltage range using the configuration utility for V _{BUS} .
		4.35	5.00	5.25	V	
V _{DDD}	V _{DDD} supply voltage	1.71	1.80	1.89	V	Used to set I/O and core voltage. Set and configure correct voltage range using the configuration utility for V _{DDD} .
		2.0	3.3	5.5	V	
V _{CCD}	Output voltage (for core logic)	-	1.80	-	V	Do not use this supply to drive external device. • 1.71 V ≤ V _{DDD} ≤ 1.89 V: Short the V _{CCD} pin with the V _{DDD} pin • V _{DDD} > 2 V – connect a 1-μF capacitor (C _{efc}) between the V _{CCD} pin and ground.
C _{efc}	External regulator voltage bypass	1.00	1.30	1.60	μF	X5R ceramic or better
I _{DD1}	Operating supply current	-	13	18	mA	USB 2.0 FS, no GPIO switching at V _{BUS} = 5 V, V _{DDD} = 5 V
I _{DD2}	USB Suspend supply current	-	5	-	μA	Does not include current through a pull-up resistor on USB DP. In USB suspend mode, the D+ voltage can go up to a maximum of 3.8 V.

Table 6. AC Specifications

Parameter	Description	Min	Typ	Max	Units	Details/Conditions
Z _{out}	USB driver output impedance	28	-	44	Ω	-
T _{wakeup}	Wakeup from USB Suspend mode	-	25	-	μs	-

Note

- Usage above the absolute maximum conditions may cause permanent damage to the device. Exposure to Absolute Maximum conditions for extended periods of time may affect device reliability. When used below Absolute Maximum conditions but above normal operating conditions the device may not operate to specification.

GPIO
Table 7. GPIO DC Specification

Parameter	Description	Min	Typ	Max	Units	Details/Conditions
$V_{IH}^{[2]}$	Input voltage high threshold	$0.7 \times V_{DDD}$	–	–	V	CMOS Input
V_{IL}	Input voltage low threshold	–	–	$0.3 \times V_{DDD}$	V	CMOS Input
$V_{IH}^{[2]}$	LVTTL input, $V_{DDD} < 2.7$ V	$0.7 \times V_{DDD}$	–	–	V	–
V_{IL}	LVTTL input, $V_{DDD} < 2.7$ V	–	–	$0.3 \times V_{DDD}$	V	–
$V_{IH}^{[2]}$	LVTTL input, $V_{DDD} \geq 2.7$ V	2	–	–	V	–
V_{IL}	LVTTL input, $V_{DDD} \geq 2.7$ V	–	–	0.8	V	–
V_{OH}	CMOS output voltage high level	$V_{DDD} - 0.4$	–	–	V	$I_{OH} = 4$ mA, $V_{DDD} = 5$ V \pm 10%
V_{OH}	CMOS output voltage high level	$V_{DDD} - 0.6$	–	–	V	$I_{OH} = 4$ mA, $V_{DDD} = 3.3$ V \pm 10%
V_{OH}	CMOS output voltage high level	$V_{DDD} - 0.5$	–	–	V	$I_{OH} = 1$ mA, $V_{DDD} = 1.8$ V \pm 5%
V_{OL}	CMOS output voltage low level	–	–	0.4	V	$I_{OL} = 8$ mA, $V_{DDD} = 5$ V \pm 10%
V_{OL}	CMOS output voltage low level	–	–	0.6	V	$I_{OL} = 8$ mA, $V_{DDD} = 3.3$ V \pm 10%
V_{OL}	CMOS output voltage low level	–	–	0.6	V	$I_{OL} = 4$ mA, $V_{DDD} = 1.8$ V \pm 5%
Rpullup	Pull-up resistor	3.5	5.6	8.5	k Ω	–
Rpulldown	Pull-down resistor	3.5	5.6	8.5	k Ω	–
I_{IL}	Input leakage current (absolute value)	–	–	2	nA	25 °C, $V_{DDD} = 3.0$ V
C_{IN}	Input capacitance	–	–	7	pF	–
Vhysttl	Input hysteresis LVTTL; $V_{DDD} > 2.7$ V	25	40	–	mV	–
Vhyscmos	Input hysteresis CMOS	$0.05 \times V_{DDD}$	–	–	mV	–

Table 8. GPIO AC Specifications

Parameter	Description	Min	Typ	Max	Units	Details/Conditions
$T_{RiseFast1}$	Rise Time in Fast mode	2	–	12	ns	$V_{DDD} = 3.3$ V/ 5.5 V, Clod = 25 pF
$T_{FallFast1}$	Fall Time in Fast mode	2	–	12	ns	$V_{DDD} = 3.3$ V/ 5.5 V, Clod = 25 pF
$T_{RiseSlow1}$	Rise Time in Slow mode	10	–	60	ns	$V_{DDD} = 3.3$ V/ 5.5 V, Clod = 25 pF
$T_{FallSlow1}$	Fall Time in Slow mode	10	–	60	ns	$V_{DDD} = 3.3$ V/ 5.5 V, Clod = 25 pF
$T_{RiseFast2}$	Rise Time in Fast mode	2	–	20	ns	$V_{DDD} = 1.8$ V, Clod = 25 pF
$T_{FallFast2}$	Fall Time in Fast mode	20	–	100	ns	$V_{DDD} = 1.8$ V, Clod = 25 pF
$T_{RiseSlow2}$	Rise Time in Slow mode	2	–	20	ns	$V_{DDD} = 1.8$ V, Clod = 25 pF
$T_{FallSlow2}$	Fall Time in Slow mode	20	–	100	ns	$V_{DDD} = 1.8$ V, Clod = 25 pF

Note

2. V_{IH} must not exceed $V_{DDD} + 0.2$ V.

nXRES
Table 9. nXRES DC Specifications

Parameter	Description	Min	Typ	Max	Units	Details/Conditions
V _{IH}	Input voltage high threshold	0.7 × V _{DDD}	–	–	V	–
V _{IL}	Input voltage low threshold	–	–	0.3 × V _{DDD}	V	–
R _{pullup}	Pull-up resistor	3.5	5.6	8.5	kΩ	–
C _{IN}	Input capacitance	–	5	–	pF	–
V _{hysxres}	Input voltage hysteresis	–	100	–	mV	–

Table 10. nXRES AC Specifications

Parameter	Description	Min	Typ	Max	Units	Details/Conditions
T _{resetwidth}	Reset pulse width	1	–	–	μs	–

SPI Specifications

Figure 2. SPI Master Timing

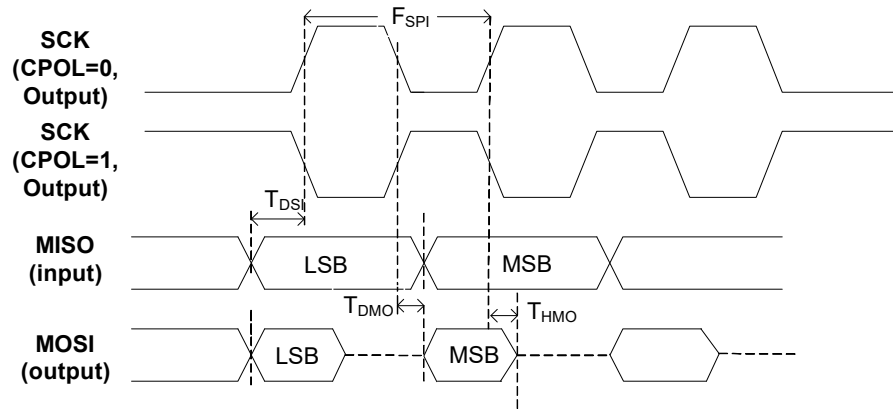

SPI Master Timing for CPHA = 0 (Refer to Table 11 and Table 12)

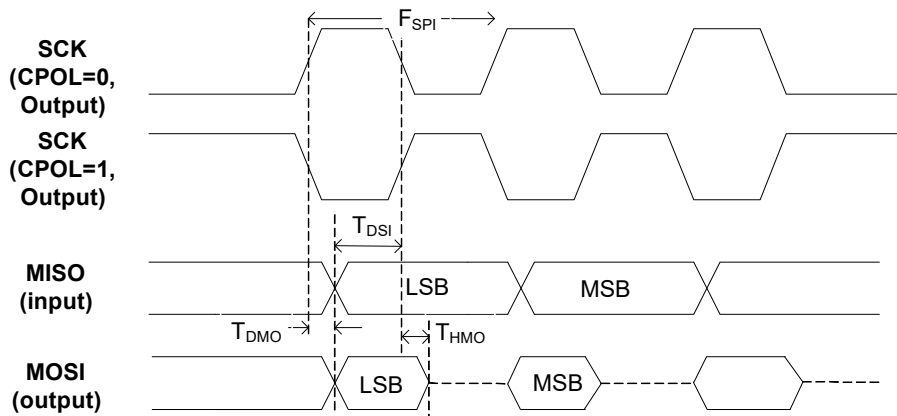

SPI Master Timing for CPHA = 1 (Refer to Table 11 and Table 12)

Figure 3. SPI Slave Timing

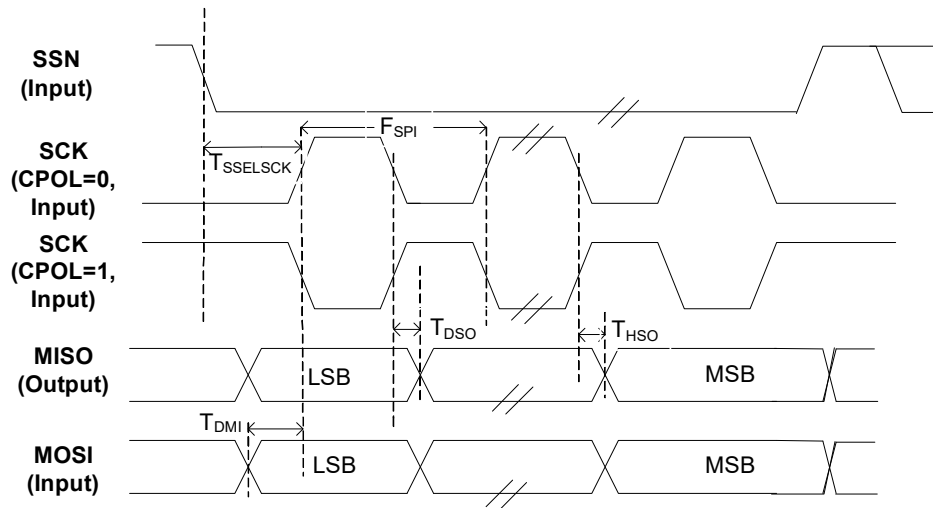

SPI Slave Timing for CPHA = 0 (Refer to Table 11 and Table 12)

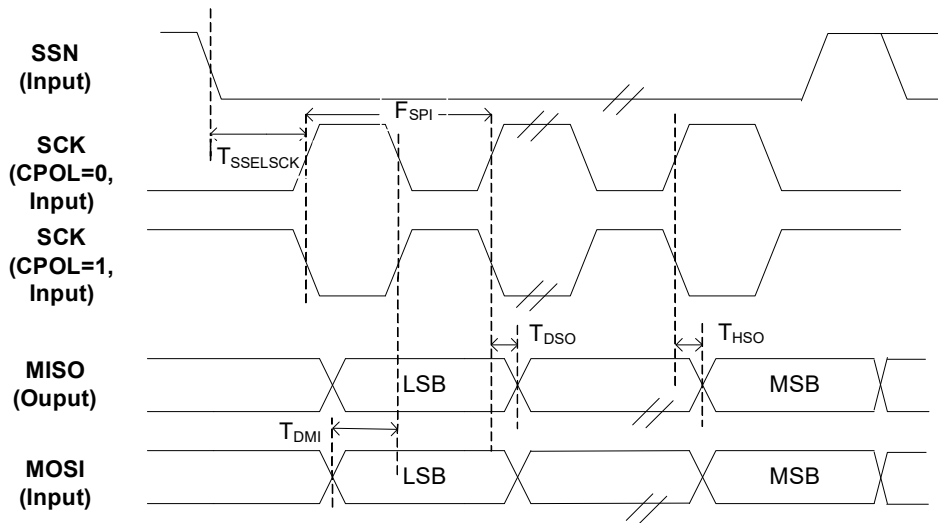

SPI Slave Timing for CPHA = 1 (Refer to Table 11 and Table 12)

Table 11. SPI AC Specifications

Parameter	Description	Min	Typ	Max	Units	Details/Conditions
F _{SPI}	SPI operating frequency (Master/Slave)	–	–	3	MHz	Single SCB: TX + RX Dual SCB: TX or RX
WL _{SPI}	SPI word length	4	–	16	bits	–
SPI Master Mode						
T _{DMO}	MOSI valid after SClk driving edge	–	–	15	ns	–
T _{DSI}	MISO valid before SClk capturing edge	20	–	–	ns	–
T _{HMO}	Previous MOSI data hold time with respect to capturing edge at slave	0	–	–	ns	–
SPI Slave Mode						
T _{DMI}	MOSI valid before SClk Capturing edge	40	–	–	ns	–
T _{DSO}	MISO valid after SClk driving edge	–	–	104.4	ns	–
T _{HSO}	Previous MISO data hold time	0	–	–	ns	–
T _{SSELSCK}	SSEL valid to first SCK valid edge	100	–	–	ns	–

Flash Memory Specifications
Table 12. Flash Memory Specifications

Parameter	Description	Min	Typ	Max	Units	Details/Conditions
F _{end}	Flash endurance	100 K	–	–	cycles	–
F _{ret}	Flash retention. T _A ≤ 85 °C, 10 K program/erase cycles.	10	–	–	years	–

Pin Description

Pin ^[3]	Type	Name		Description
1	Power	VDDD		VDDD Core
2	GPIO	GPIO_8	GPIO IN	GPIO Input Pin (see Table 15)
3	GPIO	GPIO_9	GPIO OUT	GPIO Out Pin (see Table 15)
4	Power	VSSD		Digital Ground
5	SCB/GPIO	MISO_1		SCB1 SPI MISO (Master IN Slave OUT)
6	SCB/GPIO	MOSI_1		SCB1 SPI MOSI (Master Out Slave IN)
7	SCB/GPIO	SSEL_1		SCB1 SPI Slave Select
8	SCB/GPIO	SCLK_1		SCB1 SPI Clock
9	GPIO	TX/RX LED_1		Notification LED for SPI SCB1 Tx/RX
10	GPIO	TX/RX LED_0		Notification LED for SPI SCB0 Tx/RX
11	Output	Suspend		Asserted when the part enters Low Power mode
12	Input	Wakeup		Wakeup device from suspend mode. Can be configured as active high/low using configuration utility.
13	GPIO	GPIO_16	GPIO OUT	GPIO Out Pin. Refer table 15.
14	USBIO	USBDP		USB Data Signal Plus, integrates termination resistor and a 1.5-kΩ pull-up resistor
15	USBIO	USBDM		USB Data Signal Minus, integrates termination resistor
16	Power	VCCD		This pin should be decoupled to ground using a 1-μF capacitor or by connecting a 1.8-V supply (Internal LDO Output).
17	Power	VSSD		Digital Ground
18	Reset	nXRES		Chip Reset active, low. Can be left unconnected or have a pull up resistor connected when not in use.
19	Power	VBUS		VBUS Supply, 3.15 V to 5.25 V
20	Power	VSSD (VBUS)		Digital Ground
21	GPIO	GPIO_17	GPIO OUT	GPIO Out Pin (see Table 15)
22	GPIO	GPIO_18	GPIO OUT	GPIO Out Pin (see Table 15)
23	Power	VDDD_IO		VDDD for IO pins
24	Power	VSSA		Analog Ground
25	GPIO	GPIO_0	GPIO IN	GPIO Out Pin (see Table 15)
26	GPIO	GPIO_1	GPIO IN	GPIO Out Pin (see Table 15)
27	SCB/GPIO	SSEL_0		Slave Select Enable SCB0 SPI
28	SCB/GPIO	MISO_0		SCB0 SPI MISO
29	SCB/GPIO	MOSI_0		SCB0 SPI MOSI
30	SCB/GPIO	SCLK_0		SCB0 SPI Clock
31	Output	POWER#		Signal to external logic to indicate USB Unconfigured state and USB Suspend
32	GPIO	GPIO_7	GPIO IN	GPIO Out Pin (see Table 15)

Note

3. Any pin acting as an input pin should not be left unconnected.

Figure 4. 32-Pin QFN Pinout

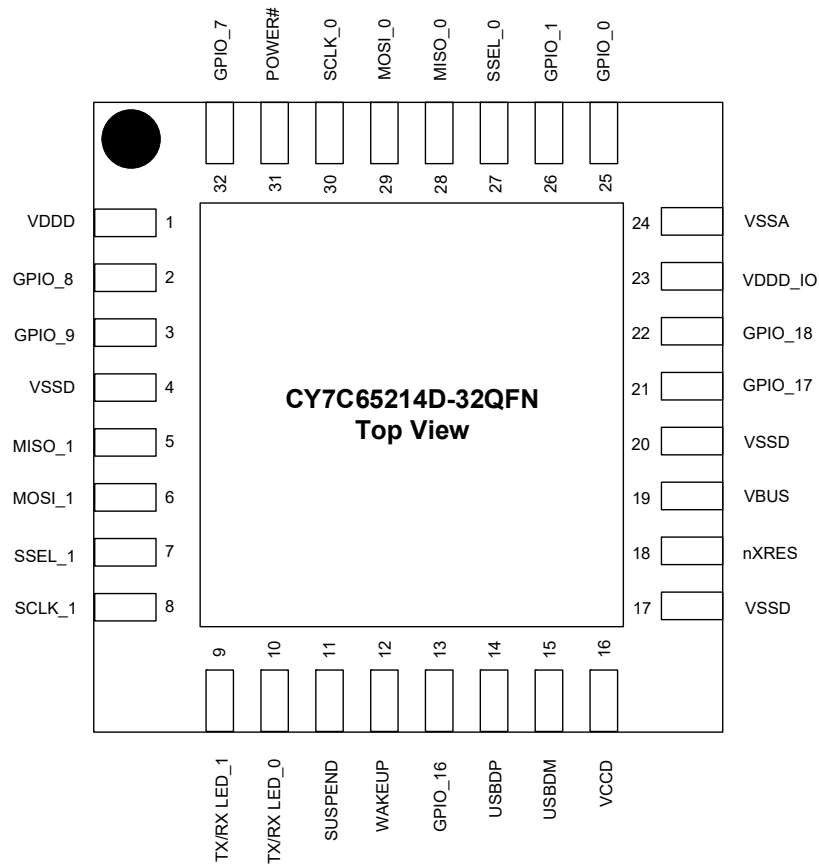

Table 13. Serial Communication Block (SCB0) Configuration

Pin	Serial Port 0	Mode 0 ^[4]	Mode 1
		SPI Master	SPI Slave
2	SCB0_0	GPIO_8	GPIO_8
27	SCB0_1	SSEL_OUT_0	SSEL_IN_0
28	SCB0_2	MISO_IN_0	MISO_OUT_0
29	SCB0_3	MOSI_OUT_0	MOSI_IN_0
30	SCB0_4	SCLK_OUT_0	SCLK_IN_0
3	SCB0_5	GPIO_9	GPIO_9

Table 14. Serial Communication Block (SCB1) Configuration

Pin	Serial Port 1	Mode 0 ^[4]	Mode 1
		SPI Master	SPI Slave
5	SCB1_0	GPIO_8	GPIO_8
6	SCB1_1	SSEL_OUT_0	SSEL_IN_0
7	SCB1_2	MISO_IN_0	MI-SO_OUT_0
8	SCB1_3	MOSI_OUT_0	MOSI_IN_0
9	SCB1_4	SCLK_OUT_0	SCLK_IN_0
10	SCB1_5	GPIO_9	GPIO_9

Legend:

	GPIO
	SCB0
	SCB1

Note

4. Device configured in Mode 0 as default. Other modes can be configured through Cypress-supplied configuration utility.

Table 15. GPIO Configuration^[5]

GPIO Configuration Option	Description
TRISTATE	I/O tristated
DRIVE 1	Output static 1
DRIVE 0	Output static 0
POWER#	This output is used to control power to an external logic via switch to cut power off during unconfigured USB device and USB suspend. 0 - USB device in Configured state 1 - USB device in Unconfigured state or during USB suspend mode
TXLED#	Drives LED during USB transmit
RXLED#	Drives LED during USB receive
TX or RX LED#	Drives LED during USB transmit or receive
BCD0 BCD1	Configurable battery charger detect pins to indicate type of USB charger (SDP, CDP, or DCP) Configuration example: 00 - Draw up to 100 mA (Unconfigured state) 01 - SDP (up to 500 mA) 10 - CDP/DCP (up to 1.5 A) 11 - Suspend (up to 2.5 mA) This truth table can be configured using the configuration utility
BUSDETECT	VBUS detection. Connect VBUS to this pin via resistor network for VBUS detection when using BCD feature (see Figure 9).

Note

5. These signal options can be configured on any of the available GPIO pins using Cypress-supplied configuration utility.

USB Power Configurations

The following section describes possible USB power configurations for the CY7C65214D. Refer to the [Pin Description on page 17](#) for signal details.

USB Bus-Powered Configuration

Figure 5 shows an example of the CY7C65214D in a bus-powered design. VBUS is connected directly to the CY7C65214D because it has an internal regulator.

The USB bus-powered system must comply with the following requirements:

1. The system should not draw more than 100 mA prior to USB enumeration (Unconfigured state).
2. The system should not draw more than 2.5 mA during USB Suspend mode.
3. A high-power bus-powered system (can draw more than 100 mA when operational) must use POWER# (configured over GPIO) to keep the current consumption below 100 mA prior to USB enumeration, and 2.5 mA during USB Suspend state.
4. The system should not draw more than 500 mA from the USB host.

The configuration descriptor in the CY7C65214D flash should be updated to indicate bus power and the maximum current required by the system using the configuration utility.

Figure 5. Bus-Powered Configuration

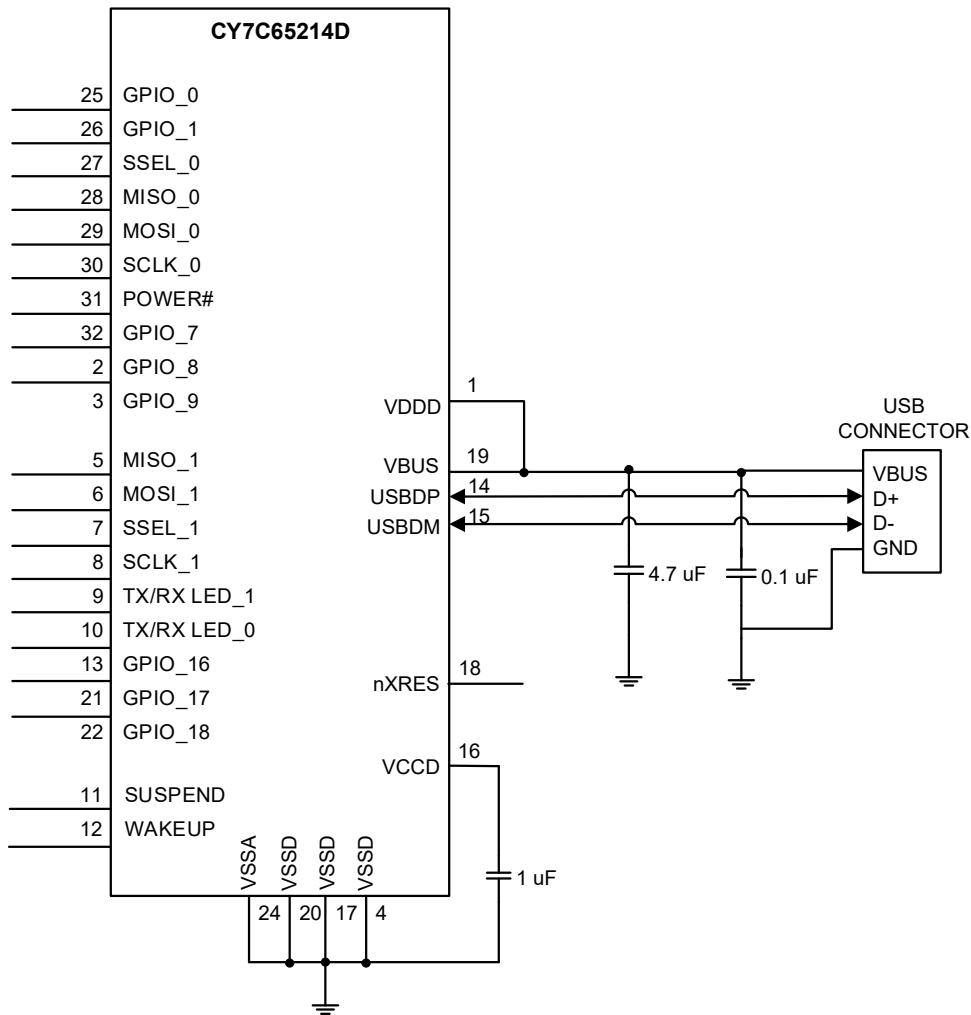

Self-Powered Configuration

Figure 6 shows an example of CY7C65214D in a self-powered design.

In this configuration:

- VBUS is powered from USB VBUS. VBUS pin is also used to detect USB connection.
- VDDD is powered from an external power supply.

When VBUS is present, CY7C65214D enables an internal, 1.5-kΩ pull-up resistor on USBDP. When VBUS is absent (USB host is powered down), CY7C65214D removes the 1.5-kΩ pull-up resistor on USBDP, and this ensures no current flows from the USBDP to the USB host via a 1.5-kΩ pull-up resistor, to comply with USB 2.0 specification.

When reset is asserted to CY7C65214D, all the I/O pins are tristated.

Using the configuration utility, the configuration descriptor in the CY7C65214D flash should be updated to indicate that it is self-powered.

Figure 6. Self-Powered Configuration

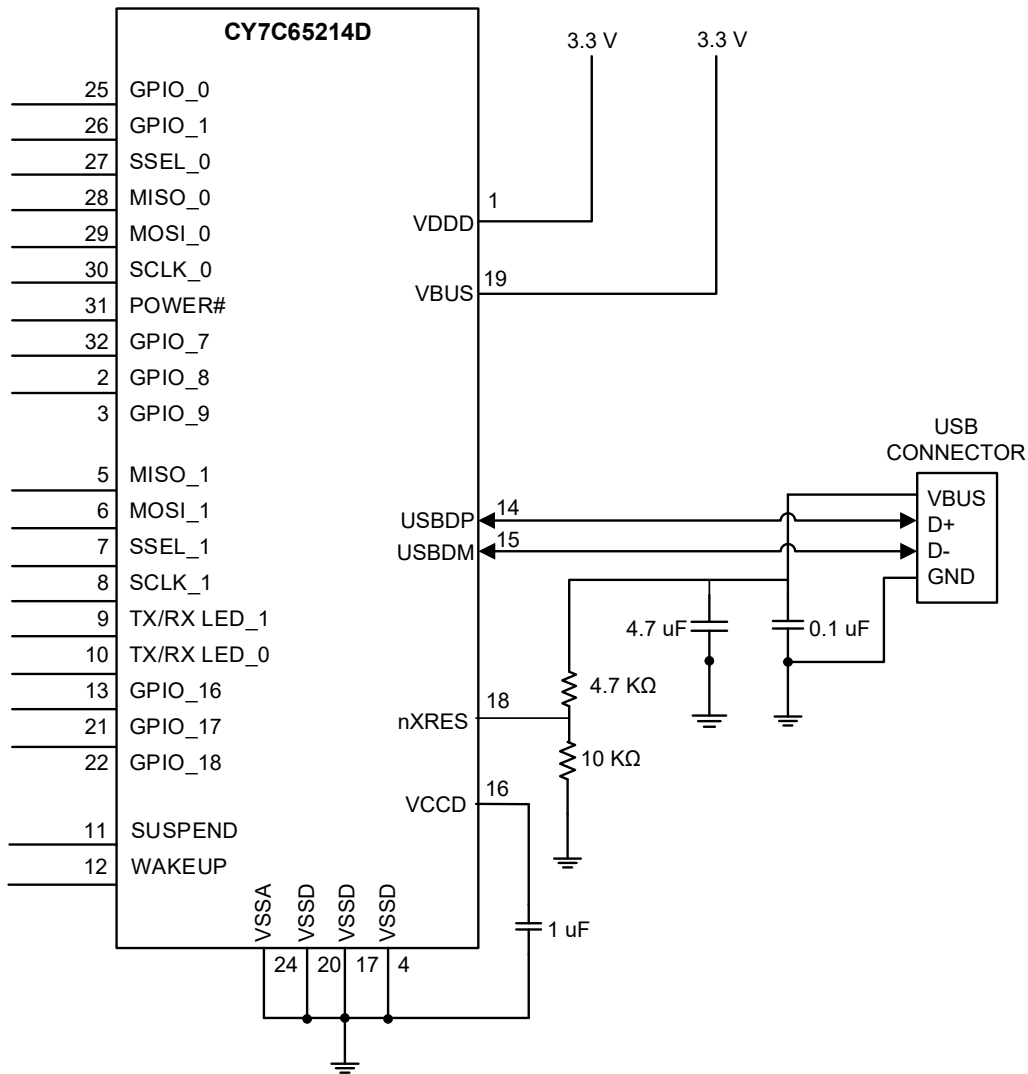

USB Bus Powered with Variable I/O Voltage

Figure 7 shows CY7C65214D in a bus-powered system with variable I/O voltage. A low dropout (LDO) regulator is used to supply 1.8 V or 3.3 V (using a jumper switch) the input of which is 5 V from VBUS. Another jumper switch is used to select 1.8/3.3 V or 5 V from VBUS for the VDDD pin of CY7C65214D. This allows I/O voltage and supply to external logic to be selected among 1.8 V, 3.3 V, or 5 V.

The USB bus-powered system must comply with the following:

- The system should not draw more than 100 mA prior to USB enumeration (Unconfigured state).
- The system should not draw more than 2.5 mA during USB Suspend mode.
- A high-power bus-powered system (can draw more than 100 mA when operational) must use POWER# (configured over GPIO) to keep the current consumption below 100 mA prior to USB enumeration and 2.5 mA during USB Suspend state.

Figure 7. USB Bus-Powered with 1.8 V, 3.3 V, or 5 V Variable I/O Voltage^[6]

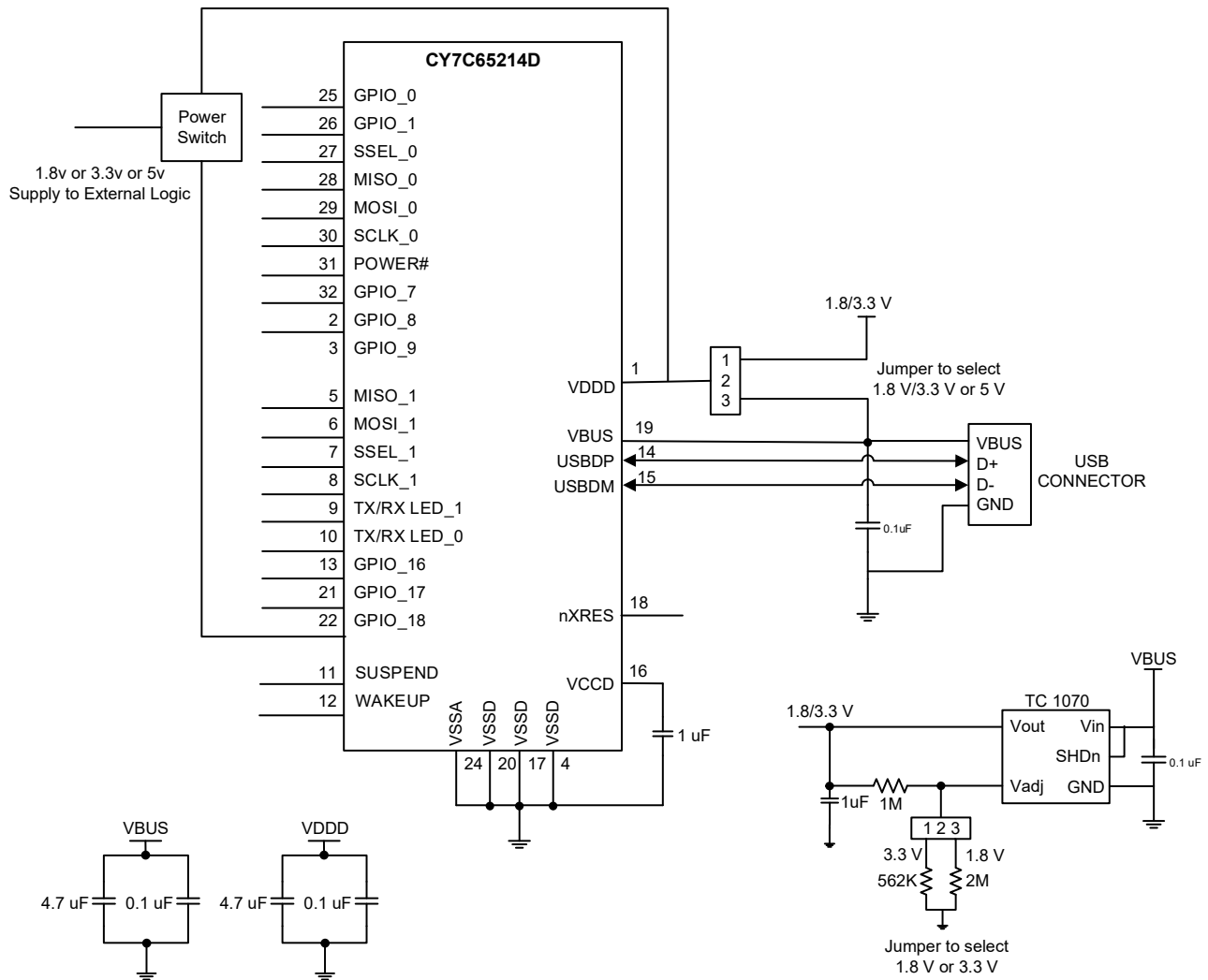

Note

6. $1.71\text{ V} \leq \text{VDDDD} \leq 1.89\text{ V}$ - Short VCCD pin with VDDDD pin; $\text{VDDDD} > 2\text{ V}$ - connect a 1- μF decoupling capacitor to the VCCD pin.

Application Examples

The following section provides CY7C65214D application examples.

USB-to-Dual SPI Bridge with Battery-Charge Detection

CY7C65214D can connect any embedded system, with a serial port, to a host PC through USB. CY7C65214D enumerates as a dual COM port on the host PC.

SUSPEND is connected to the MCU to indicate USB suspend or USB Unconfigured and the WAKEUP pin is used to wake up CY7C65214D, which in turn issues a remote wakeup to the USB host. GPIO1 and GPIO0 are configured as RXLED# and TXLED# to drive two LEDs indicating data receive and transmit respectively.

CY7C65214D implements the battery charger detection functionality based on the USB Battery Charging Specification Rev 1.2.

Battery-operated bus power systems must comply with the following conditions:

- The system can be powered from the battery (if not discharged) and be operational if VBUS is not connected or powered down.
- The system should not draw more than 100 mA from the VBUS prior to USB enumeration and USB Suspend mode.
- The system should not draw more than 500 mA for SDP and 1.5 A for CDP/DCP

To comply with the first requirement, VBUS from the USB host is connected to the battery charger as well as CY7C65214D as shown in Figure 8. When VBUS is connected, CY7C65214D initiates battery charger detection and indicates the type of USB charger over BCD0 and BCD1. If the USB charger is SDP or CDP, CY7C65214D enables a 1.5-K pull-up resistor on the USBDP for Full-Speed enumeration. When VBUS is disconnected CY7C65214D indicates absence of the USB charger over BCD0 and BCD1, and removes the 1.5-K pull-up resistor on USBDP. Removing this resistor ensures no current flows from the supply to the USB host through the USBDP, to comply with the USB 2.0 specification.

To comply with the second and third requirements, two signals (BCD0 and BCD1) are configured over GPIO to communicate the type of USB host charger and the amount of current it can draw from the battery charger. The BCD0 and BCD1 signals can be configured using the configuration utility.

Figure 8. USB to Dual SPI Bridge with Battery Charge Detection^[7, 8]

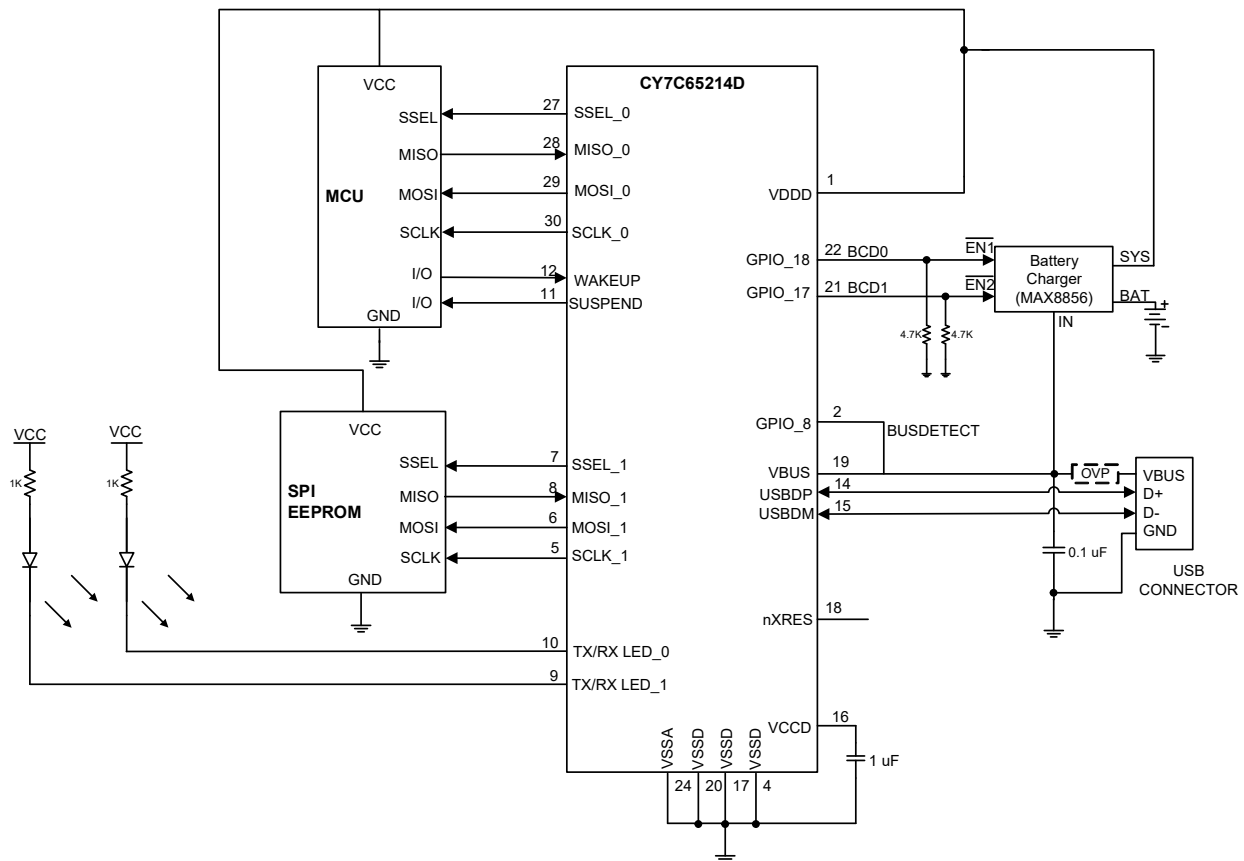

Notes

7. Add a 100-kΩ pull-down resistor on the V_{BUS} pin for quick discharge.
8. Refer Figure 9, Figure 10, Figure 11 and the corresponding descriptions for handling VBUS Over Voltage Protection (OVP).

In a battery charger system, a 9-V spike on the VBUS is possible. The CY7C65214D VBUS pin is intolerant to voltage above 6 V. In the absence of over-voltage protection (OVP) on the VBUS line, VBUS should be connected to BUSDETECT (GPIO configured) using the resistive network and the output of battery charger to the VBUS pin of CY7C65214D, as shown in Figure 9.

Figure 9. GPIO VBUS Detect (BUSDETECT)

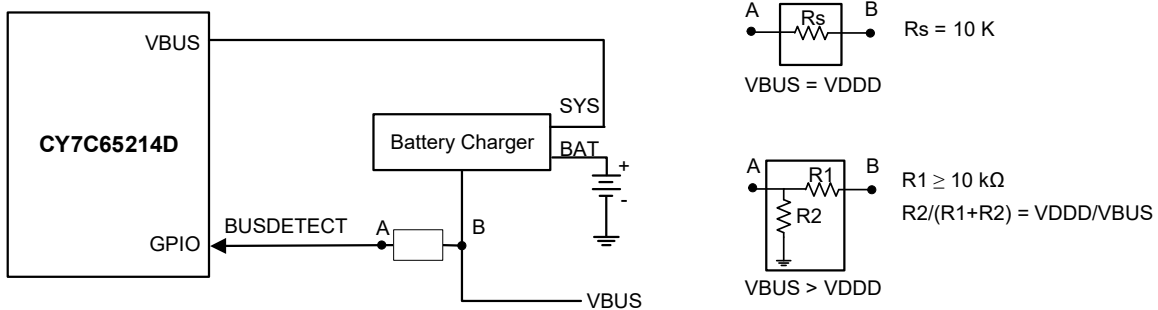

When VBUS and VDDD are at the same voltage potential, VBUS can be connected to GPIO using a series resistor (R_s). This is shown in Figure 10. If there is a charger failure and VBUS becomes 9 V, then the 10-k Ω resistor plays two roles. It reduces the amount of current flowing into the forward biased diodes in the GPIO, and it reduces the voltage seen on the pad.

Figure 10. GPIO VBUS Detection, VBUS = VDDD

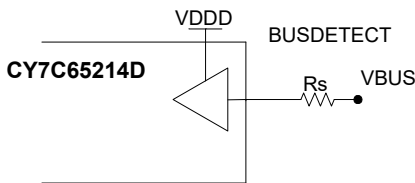

When $VBUS > VDDD$, a resistor voltage divider is necessary to reduce the voltage from VBUS down to VDDD for the GPIO sensing the VBUS voltage (see Figure 11). The resistors should be sized as follows:

$$R_1 \geq 10 \text{ K}$$

$$R_2 / (R_1 + R_2) = V_{DDD} / V_{BUS}$$

The first condition limits the voltage and current for the charger failure situation, as described in the previous paragraph, while the second condition allows for normal-operation VBUS detection.

Figure 11. GPIO VBUS Detection, VBUS > VDDD

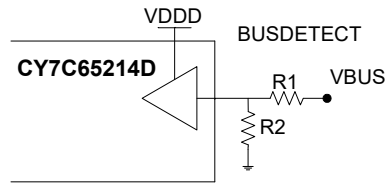

USB to Dual Channel (SPI) Bridge

In Figure 12, CY7C65214D is a USB-to-Dual Channel SPI Bridge. GPIO1 and GPIO0 are configured as RXLED# and TXLED# to drive two LEDs indicating data USB receive and transmit respectively.

Figure 12. USB-to-SPI Bridge

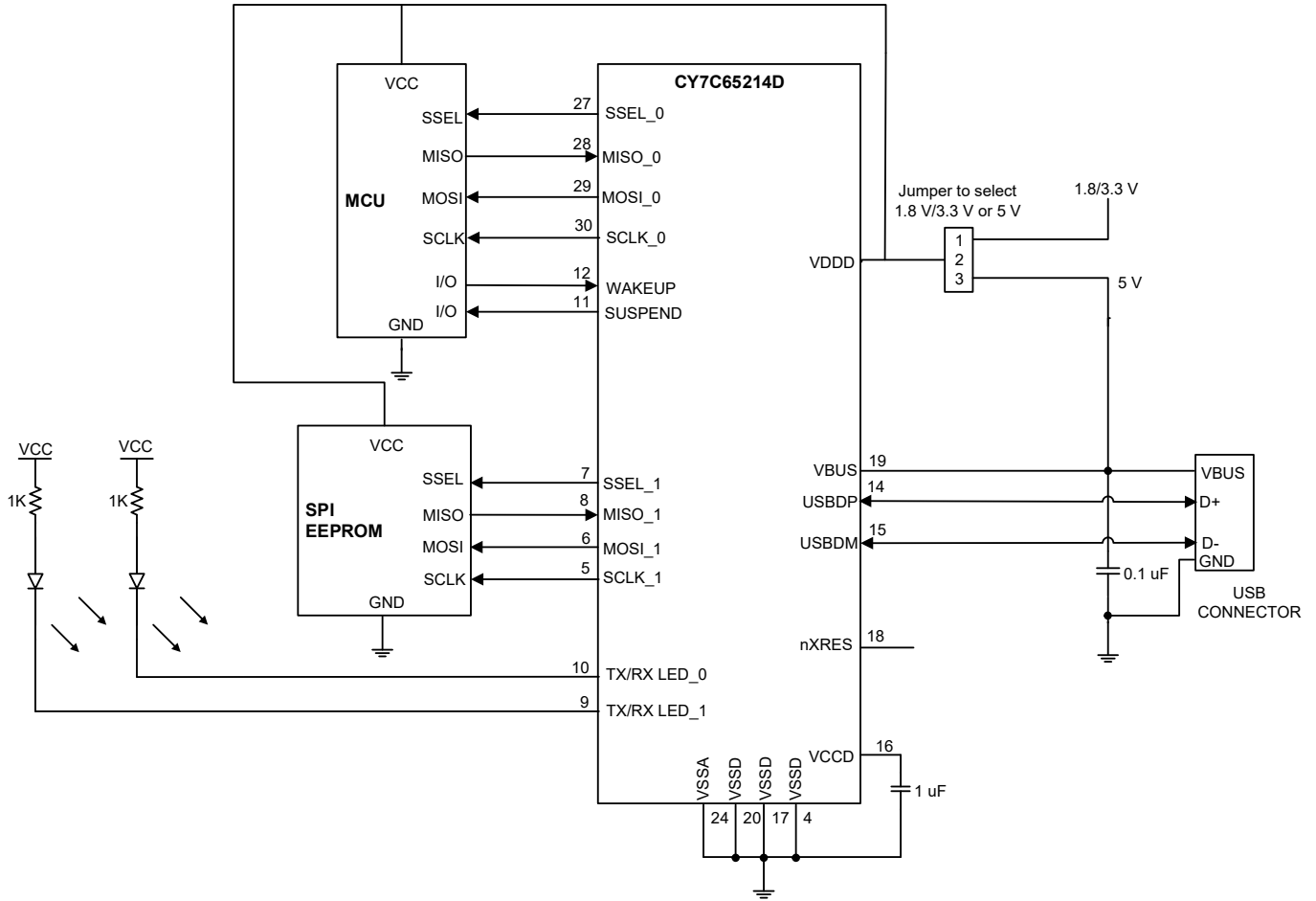

SPI

The CY7C65214D SPI can be configured as a Master or Slave using the configuration utility. CY7C65214D supports SPI master frequency up to 3 MHz and SPI slave frequency up to 1 MHz. It can support transaction sizes ranging from 4 bits to 16 bits, which can be configured using the configuration utility.

In the master mode, SCLK, MOSI and SSEL lines act as output and MISO acts as an input. In the slave mode, SCL SCLK, MOSI, and SSEL lines act as input and MISO acts as an output.

CY7C65214D supports three versions of the SPI protocol:

- Motorola - This is the original SPI protocol.
- Texas Instruments - A variation of the original SPI protocol in which data frames are identified by a pulse on the SSEL line.
- National Semiconductors - A half-duplex variation of the original SPI protocol.

Motorola

The original SPI protocol is defined by Motorola. It is a full-duplex protocol: transmission and reception occur at the same time.

A single (full-duplex) data transfer follows these steps: The master selects a slave by driving its SSEL line to '0'. Next, it drives data on its MOSI line and it drives a clock on its SCLK line. The slave uses the edges of the transmitted clock to capture the data on the MOSI line. The slave drives data on its MISO line. The master captures the data on the MISO line. The process is repeated for all the bits in the data transfer.

Multiple data transfers may happen without the SSEL line changing from '0' to '1' and back from '1' to '0' in between the individual transfers. As a result, slaves must keep track of the progress of data transfers to separate individual transfers.

When not transmitting data, the SSEL line is '1' and SCLK is typically off.

The Motorola SPI protocol has four different modes that determine how data is driven and captured on the MOSI and MISO lines. These modes are determined by clock polarity (CPOL) and clock phase (CPHA). Clock polarity determines the value of the SCLK line when not transmitting data:

- CPOL is '0': SCLK is '0' when not transmitting data.
- CPOL is '1': SCLK is '1' when not transmitting data.

Clock phase determines when data is driven and captured. It is dependent on the value of CPOL.

Table 16. SPI Protocol Modes

Mode	CPOL	CPHA	Description
0	0	0	Data is driven on a falling edge of SCLK. Data is captured on a rising edge of SCLK.
1	0	1	Data is driven on a rising edge of SCLK. Data is captured on a falling edge of SCLK.
2	1	0	Data is driven on a rising edge of SCLK. Data is captured on a falling edge of SCLK.
3	1	1	Data is driven on a falling edge of SCLK. Data is captured on a rising edge of SCLK.

Figure 13. Driving and Capturing of MOSI/MISO Data as a Function of CPOL and CPHA

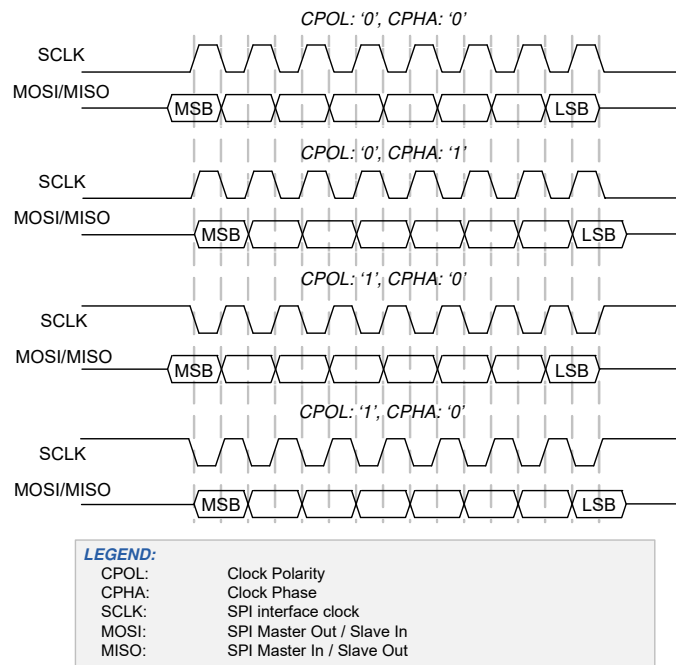
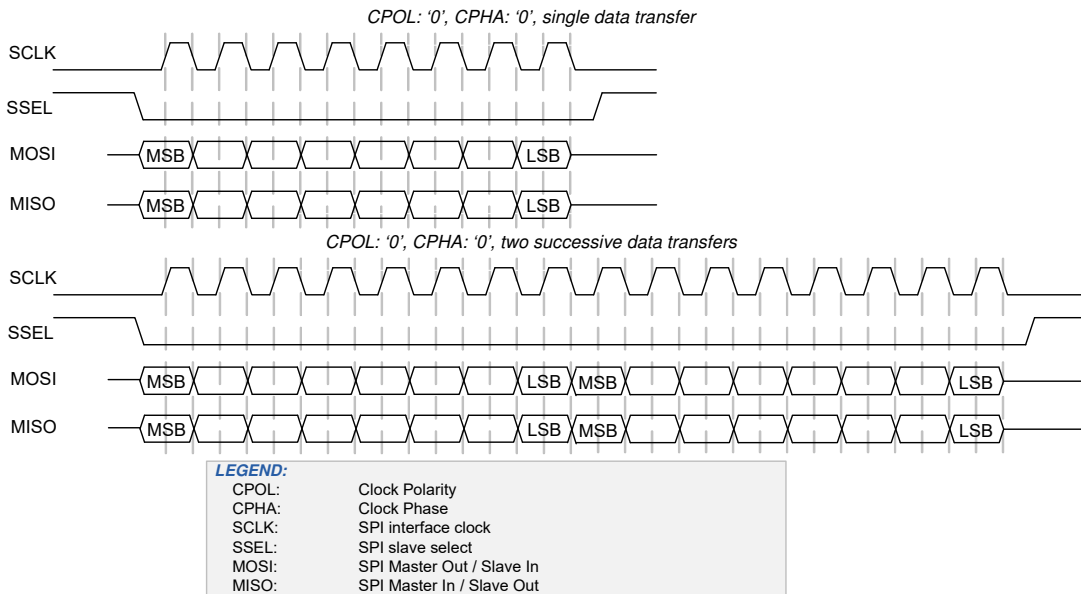

Figure 14. Single 8-bit Data Transfer and Two Successive 8-bit Data Transfers in Mode 0 (CPOL is '0', CPHA is '0')



Texas Instruments

The Texas Instruments' SPI protocol redefines the use of the SSEL signal. It uses the signal to indicate the start of a data transfer, rather than a low, active slave-select signal. The start of a transfer is indicated by a high, active pulse of a single-bit transfer period. This pulse may occur one cycle before the transmission of the first data bit, or may coincide with the transmission of the first data bit. The transmitted clock SCLK is a free-running clock.

The TI SPI protocol only supports mode 1 (CPOL is '0' and CPHA is '1'): data is driven on a rising edge of SCLK and data is captured on a falling edge of SCLK.

The following figure illustrates a single 8-bit data transfer and two successive 8-bit data transfers. The SSEL pulse precedes the first data bit. Note how the SSEL pulse of the second data transfer coincides with the last data bit of the first data transfer.

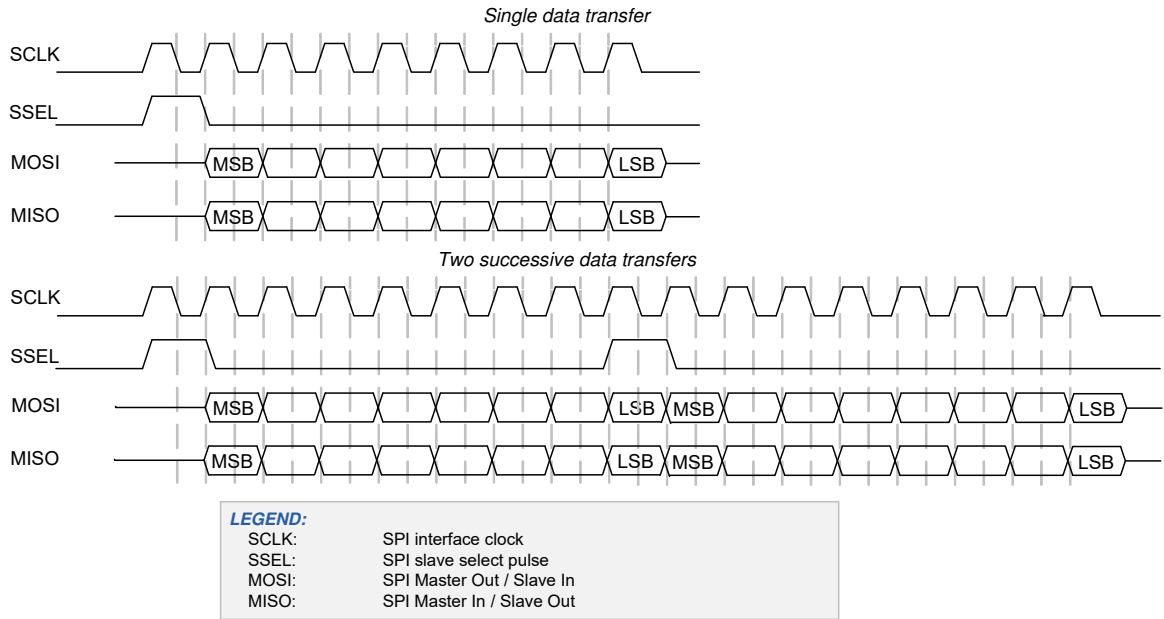

The following figure illustrates a single 8-bit data transfer and two successive 8-bit data transfers. The SSEL pulse coincides with the first data bit.

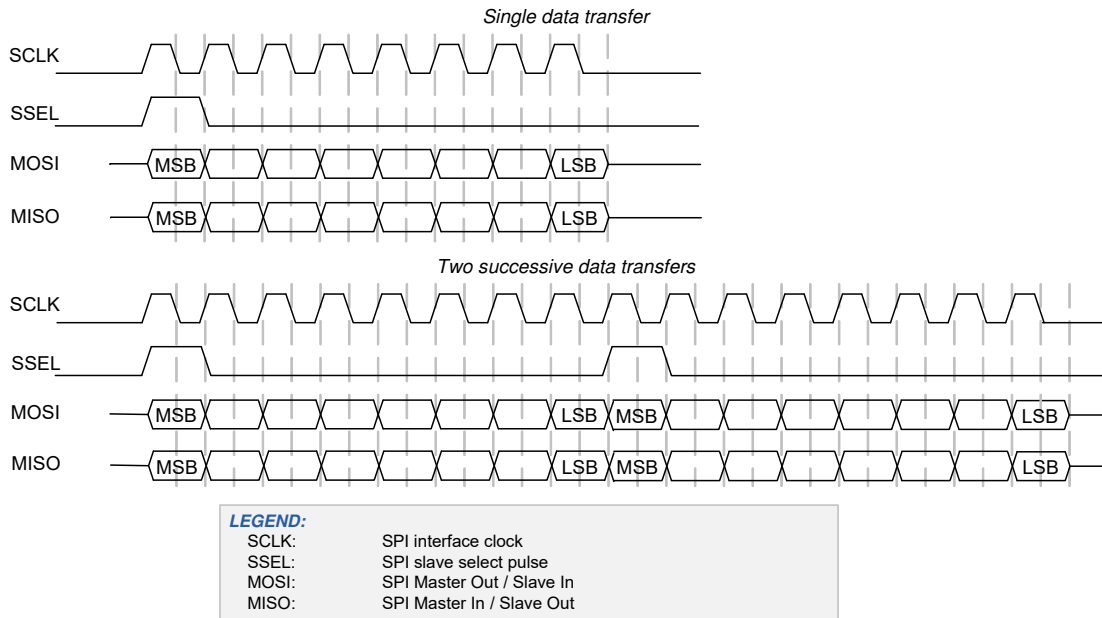

National Semiconductors

The National Semiconductors' SPI protocol is a half-duplex protocol. Rather than transmission and reception occurring at the same time, transmission and reception take turns (transmission happens before reception). A single "idle" bit transfer period separates transmission from reception.

Note Successive data transfers are NOT separated by an "idle" bit transfer period.

The transmission data transfer size and reception data transfer size may differ. The National Semiconductors' SPI protocol only supports mode 0: data is driven on a falling edge of SCLK and data is captured on a rising edge of SCLK.

The following figure illustrates a single data transfer and two successive data transfers. In both cases, the transmission data transfer size is 8 bits and the reception transfer size is 4 bits.

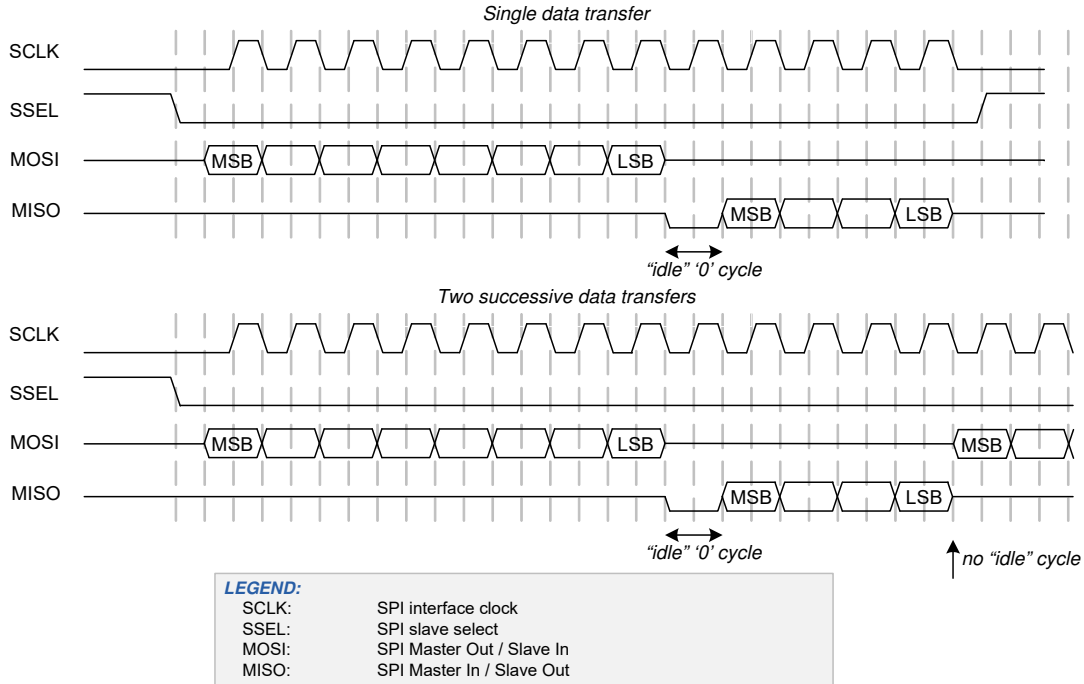

The above figure defines MISO and MOSI as undefined when the lines are considered idle (not carrying valid information). It will drive the outgoing line values to '0' during idle time (to satisfy the requirements of specific master devices (NXP LPC17xx) and specific slave devices (MicroChip EEPROM)).

Ordering Information

Table 17 lists the CY7C65214D key package features and ordering codes. For more information, contact your local sales representative.

Table 17. Key Features and Ordering Information

Package	Ordering Code	Operating Range
32-pin QFN (5 × 5 × 1 mm, 0.5 mm pitch) (Pb-free)	CY7C65214D-32LTXI	Industrial
32-pin QFN (5 × 5 × 1 mm, 0.5 mm pitch) (Pb-free) – Tape and Reel	CY7C65214D-32LTXIT	Industrial

Ordering Code Definitions

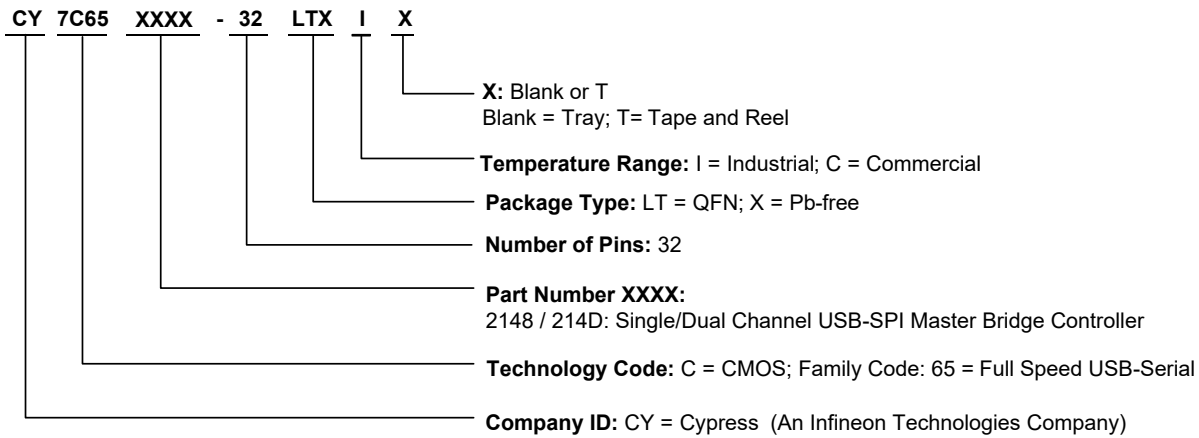

Package Information

The package currently planned to be supported is the 32-pin QFN.

Figure 15. 32-pin QFN 5 × 5 × 1.0 mm LT32B 3.5 × 3.5 EPAD (Sawn)

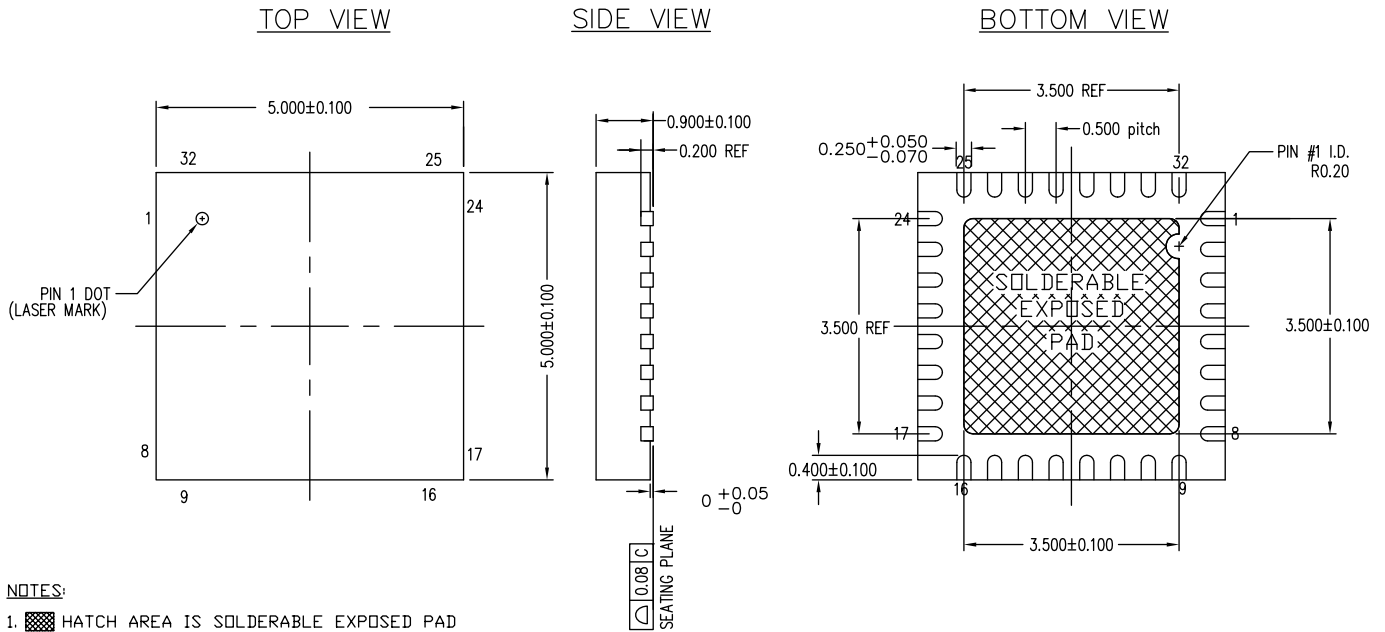

NOTES:

1. [Hatched Area] HATCH AREA IS SOLDERABLE EXPOSED PAD
2. BASED ON REF JEDEC # MO-220
3. DIMENSIONS ARE IN MILLIMETERS
4. PACKAGE WEIGHT: SEE CYPRESS PACKAGE MATERIAL DECLARATION DATASHEET (PMDD) POSTED ON THE CYPRESS WEB

001-30999 *D

Table 18. Package Characteristics

Parameter	Description	Min	Typ	Max	Units
T _A	Operating ambient temperature	-40	25	85	°C
THJ	Package θ _{JA}	-	19	-	°C/W

Table 19. Solder Reflow Peak Temperature

Package	Maximum Peak Temperature	Maximum Time at Peak Temperature
32-pin QFN	260 °C	30 seconds

Table 20. Package Moisture Sensitivity Level (MSL), IPC/JEDEC J-STD-2

Package	MSL
32-pin QFN	MSL 3

Acronyms

Table 21. Acronyms Used in this Document

Acronym	Description
BCD	battery charger detection
CDC	communication driver class
CDP	charging downstream port
DCP	dedicated charging port
DLL	dynamic link library
ESD	electrostatic discharge
GPIO	general purpose input/output
HBM	human-body model
MCU	Microcontroller Unit
OSC	oscillator
PHDC	personal health care device class
PID	Product Identification
SCB	serial communication block
SDP	Standard Downstream Port
SIE	serial interface engine
SPI	serial peripheral interface
VCOM	virtual communication port
USB	Universal Serial Bus
VID	Vendor Identification

Document Conventions

Units of Measure

Table 22. Units of Measure

Symbol	Unit of Measure
°C	degree Celsius
DMIPS	dhystone million instructions per second
kΩ	kilo-ohm
KB	kilobyte
kHz	kilohertz
kV	kilovolt
Mbps	megabits per second
MHz	megahertz
mm	millimeter
V	volt

Document History Page

Document Title: CY7C65214D, USB-Serial Dual Channel SPI Bridge Document Number: 002-31604			
Revision	ECN	Submission Date	Description of Change
**	6993251	12/01/2020	Final datasheet to NSO.

Sales, Solutions, and Legal Information

Worldwide Sales and Design Support

Cypress maintains a worldwide network of offices, solution centers, manufacturer's representatives, and distributors. To find the office closest to you, visit us at [Cypress Locations](#).

Products

Arm [®] Cortex [®] Microcontrollers	cypress.com/arm
Automotive	cypress.com/automotive
Clocks & Buffers	cypress.com/clocks
Interface	cypress.com/interface
Internet of Things	cypress.com/iot
Memory	cypress.com/memory
Microcontrollers	cypress.com/mcu
PSoC	cypress.com/psoc
Power Management ICs	cypress.com/pmic
Touch Sensing	cypress.com/touch
USB Controllers	cypress.com/usb
Wireless Connectivity	cypress.com/wireless

PSoC[®] Solutions

[PSoC 1](#) | [PSoC 3](#) | [PSoC 4](#) | [PSoC 5LP](#) | [PSoC 6 MCU](#)

Cypress Developer Community

[Community](#) | [Code Examples](#) | [Projects](#) | [Video](#) | [Blogs](#) | [Training](#) | [Components](#)

Technical Support

cypress.com/support

© Cypress Semiconductor Corporation, 2020. This document is the property of Cypress Semiconductor Corporation and its subsidiaries ("Cypress"). This document, including any software or firmware included or referenced in this document ("Software"), is owned by Cypress under the intellectual property laws and treaties of the United States and other countries worldwide. Cypress reserves all rights under such laws and treaties and does not, except as specifically stated in this paragraph, grant any license under its patents, copyrights, trademarks, or other intellectual property rights. If the Software is not accompanied by a license agreement and you do not otherwise have a written agreement with Cypress governing the use of the Software, then Cypress hereby grants you a personal, non-exclusive, nontransferable license (without the right to sublicense) (1) under its copyright rights in the Software (a) for Software provided in source code form, to modify and reproduce the Software solely for use with Cypress hardware products, only internally within your organization, and (b) to distribute the Software in binary code form externally to end users (either directly or indirectly through resellers and distributors), solely for use on Cypress hardware product units, and (2) under those claims of Cypress's patents that are infringed by the Software (as provided by Cypress, unmodified) to make, use, distribute, and import the Software solely for use with Cypress hardware products. Any other use, reproduction, modification, translation, or compilation of the Software is prohibited.

TO THE EXTENT PERMITTED BY APPLICABLE LAW, CYPRESS MAKES NO WARRANTY OF ANY KIND, EXPRESS OR IMPLIED, WITH REGARD TO THIS DOCUMENT OR ANY SOFTWARE OR ACCOMPANYING HARDWARE, INCLUDING, BUT NOT LIMITED TO, THE IMPLIED WARRANTIES OF MERCHANTABILITY AND FITNESS FOR A PARTICULAR PURPOSE. No computing device can be absolutely secure. Therefore, despite security measures implemented in Cypress hardware or software products, Cypress shall have no liability arising out of any security breach, such as unauthorized access to or use of a Cypress product. CYPRESS DOES NOT REPRESENT, WARRANT, OR GUARANTEE THAT CYPRESS PRODUCTS, OR SYSTEMS CREATED USING CYPRESS PRODUCTS, WILL BE FREE FROM CORRUPTION, ATTACK, VIRUSES, INTERFERENCE, HACKING, DATA LOSS OR THEFT, OR OTHER SECURITY INTRUSION (collectively, "Security Breach"). Cypress disclaims any liability relating to any Security Breach, and you shall and hereby do release Cypress from any claim, damage, or other liability arising from any Security Breach. In addition, the products described in these materials may contain design defects or errors known as errata which may cause the product to deviate from published specifications. To the extent permitted by applicable law, Cypress reserves the right to make changes to this document without further notice. Cypress does not assume any liability arising out of the application or use of any product or circuit described in this document. Any information provided in this document, including any sample design information or programming code, is provided only for reference purposes. It is the responsibility of the user of this document to properly design, program, and test the functionality and safety of any application made of this information and any resulting product. "High-Risk Device" means any device or system whose failure could cause personal injury, death, or property damage. Examples of High-Risk Devices are weapons, nuclear installations, surgical implants, and other medical devices. "Critical Component" means any component of a High-Risk Device whose failure to perform can be reasonably expected to cause, directly or indirectly, the failure of the High-Risk Device, or to affect its safety or effectiveness. Cypress is not liable, in whole or in part, and you shall and hereby do release Cypress from any claim, damage, or other liability arising from any use of a Cypress product as a Critical Component in a High-Risk Device. You shall indemnify and hold Cypress, its directors, officers, employees, agents, affiliates, distributors, and assigns harmless from and against all claims, costs, damages, and expenses, arising out of any claim, including claims for product liability, personal injury or death, or property damage arising from any use of a Cypress product as a Critical Component in a High-Risk Device. Cypress products are not intended or authorized for use as a Critical Component in any High-Risk Device except to the limited extent that (i) Cypress's published data sheet for the product explicitly states Cypress has qualified the product for use in a specific High-Risk Device, or (ii) Cypress has given you advance written authorization to use the product as a Critical Component in the specific High-Risk Device and you have signed a separate indemnification agreement.

Cypress, the Cypress logo, Spansion, the Spansion logo, and combinations thereof, WICED, PSoC, CapSense, EZ-USB, F-RAM, and Traveo are trademarks or registered trademarks of Cypress in the United States and other countries. For a more complete list of Cypress trademarks, visit cypress.com. Other names and brands may be claimed as property of their respective owners.