

THIS DRAWING IS UNPUBLISHED. RELEASED FOR PUBLICATION  
 © COPYRIGHT - By - ALL RIGHTS RESERVED.

LOC	DIST	REVISIONS					
CM	00	P	LTR	DESCRIPTION	DATE	DWN	APVD
		P2		REVISED PER ECO-12-014997	22AUG12	KH	SM

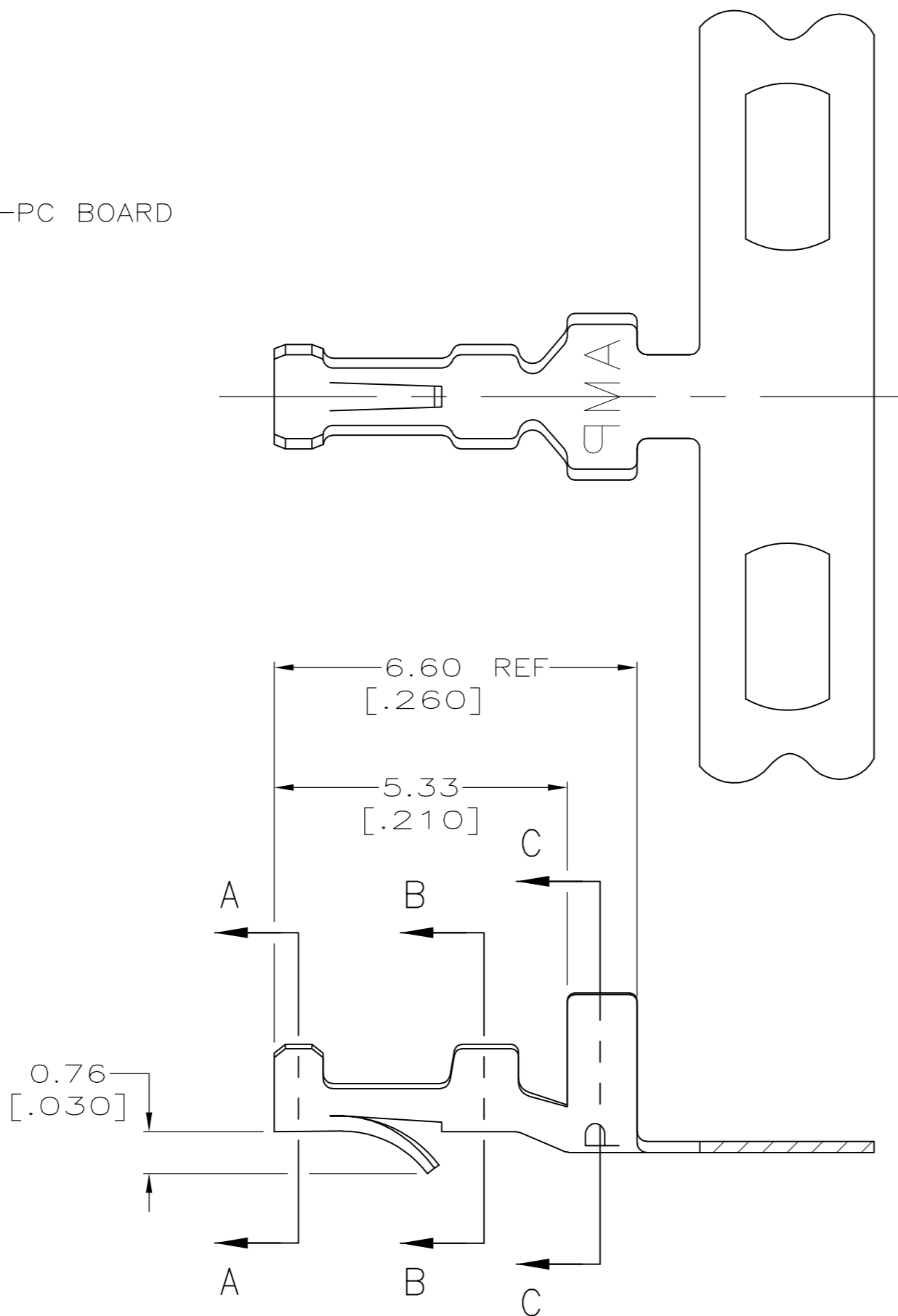

- 1 PARTS COMPLY WITH AMP SOLDERABILITY SPEC 109-11-3.
- 2 PARTS CAPABLE OF BEING APPLIED BY AMPOMATOR.
- 3 0.00508 [.000200] MIN BRIGHT TIN-LEAD.
- 4 0.00381 [.000150] MIN BRIGHT TIN-LEAD OVER 0.00127 [.000050] MIN NICKEL.
- 5 WIRE RANGE: 0.12 - 0.4 mm<sup>2</sup> (26 - 22 AWG).
- 6 INSULATION RANGE: 1.02 - 2.54 [.040 - .100] DIA.
- 7 DIMENSIONS IN BRACKETS ARE IN INCHES.
- 8 0.00508 [.000200] MIN BRIGHT TIN.

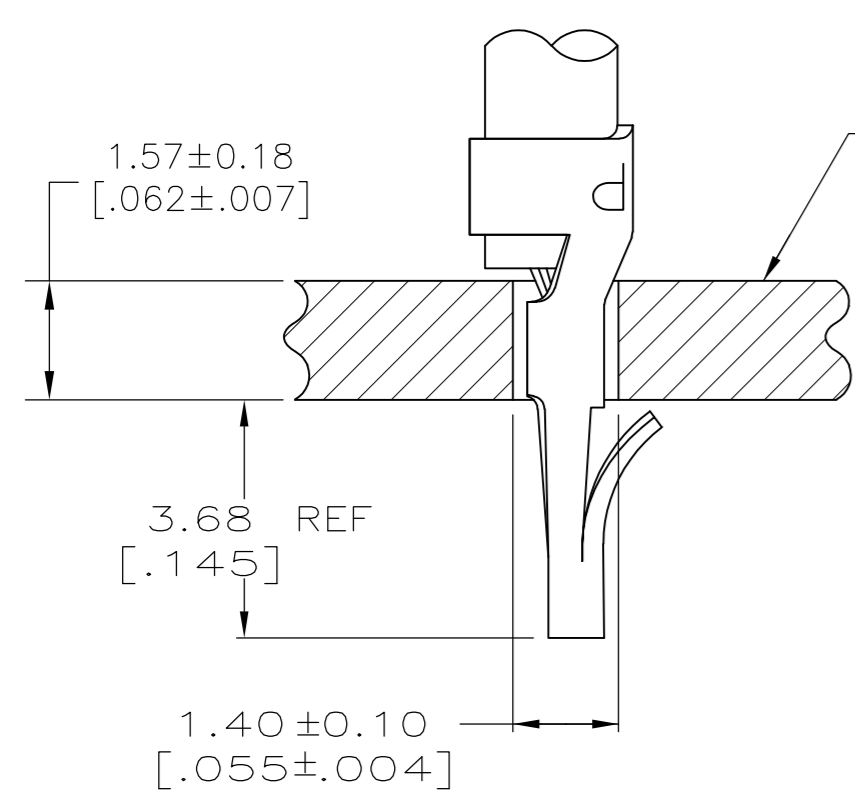
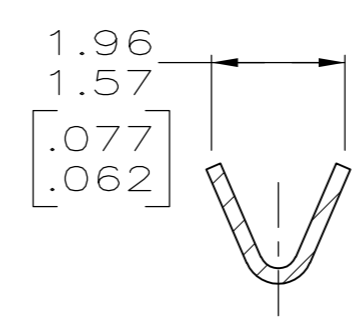

SECTION A-A, B-B

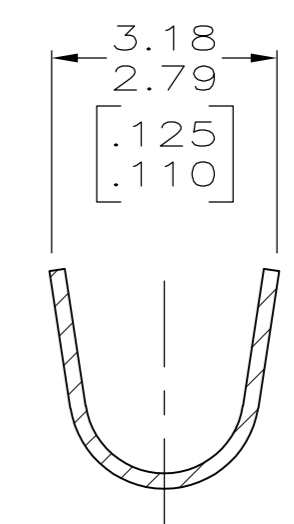

SECTION C-C

	MINI	8	0.20[.008] PH BRZ	3-640401-1
	MINI	4	0.20[.008] PH BRZ	640401-3
SUPERSEDED BY 3-640401-1	MINI	3	0.20[.008] PH BRZ	640401-1
	APPLICATOR	FINISH	MATERIAL	PART NO

METRIC

THIS DRAWING IS A CONTROLLED DOCUMENT.

DWN S. CARPENTER 21AUG2003	TE Connectivity MINI AMP-IN™			
CHK J. ELLIS 21AUG2003				
APVD J. ELLIS 21AUG2003				
PRODUCT SPEC				
APPLICATION SPEC 114-1016	SIZE A2	CAGE CODE 00779	DRAWING NO C-640401	RESTRICTED TO -
MATERIAL SEE TABLE	FINISH SEE TABLE	WEIGHT	CUSTOMER DRAWING	SCALE 10:1
			SHEET 1 of 1	REV P2