

REV	ECN NO.	DR	DATE
A		HZ	2011-09-09

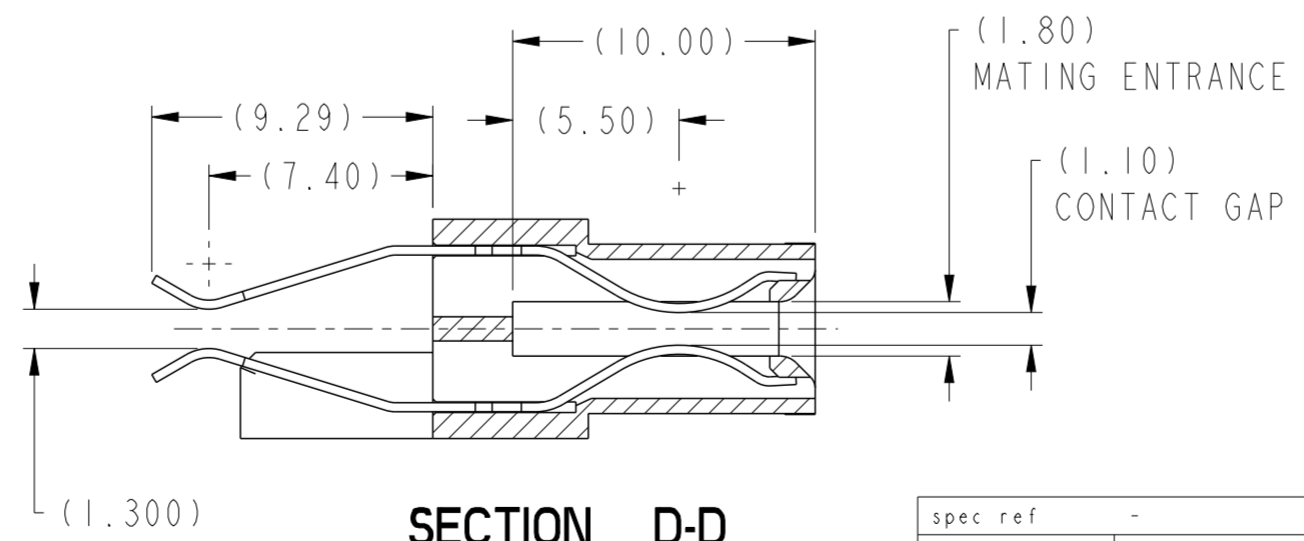
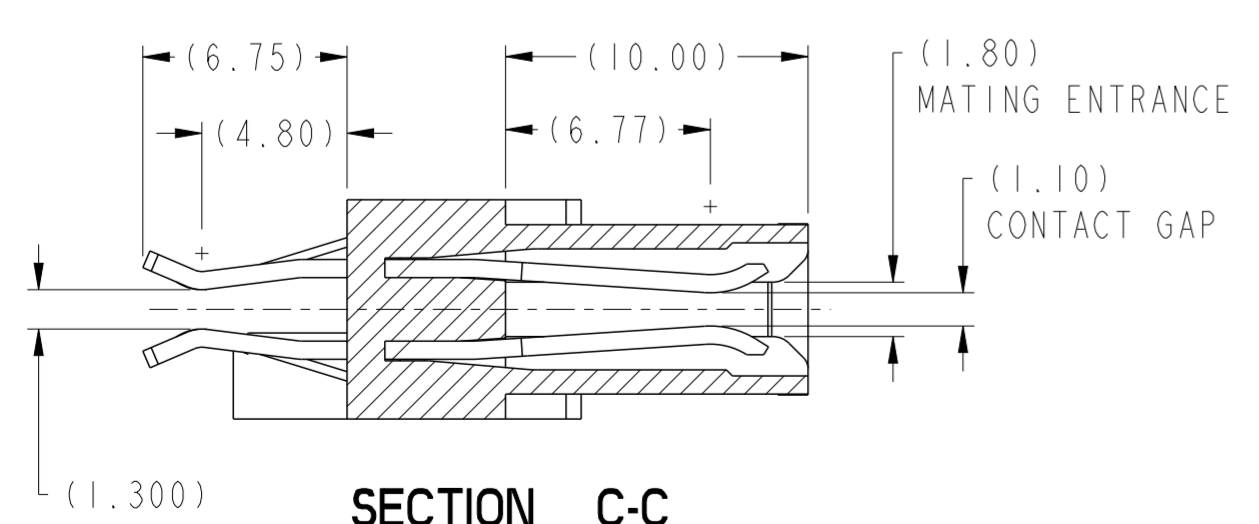
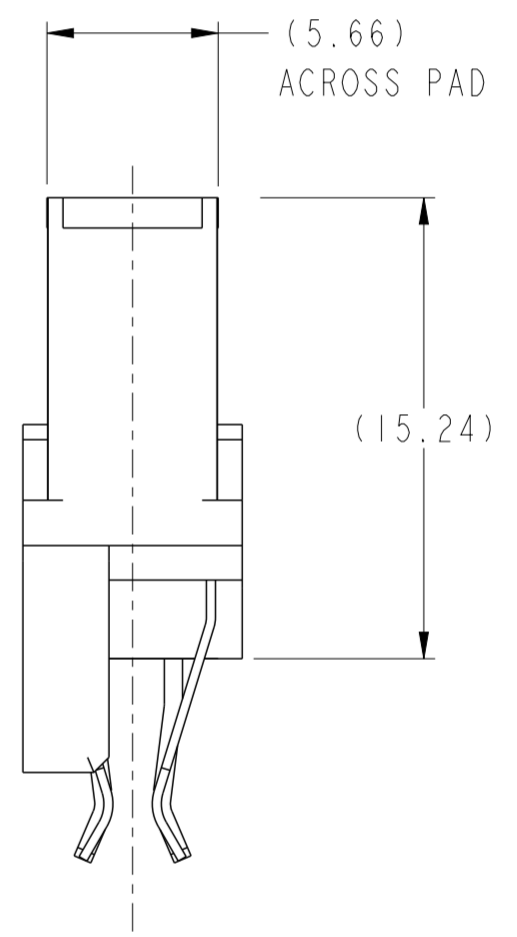
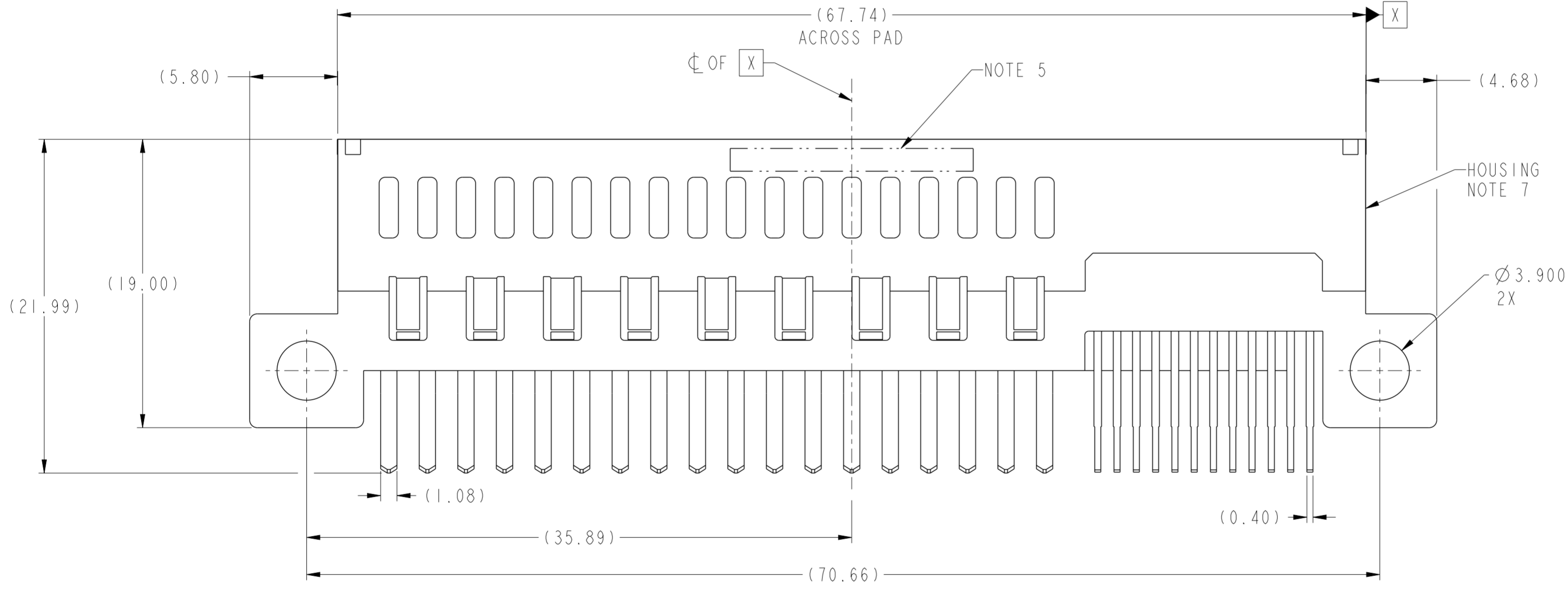
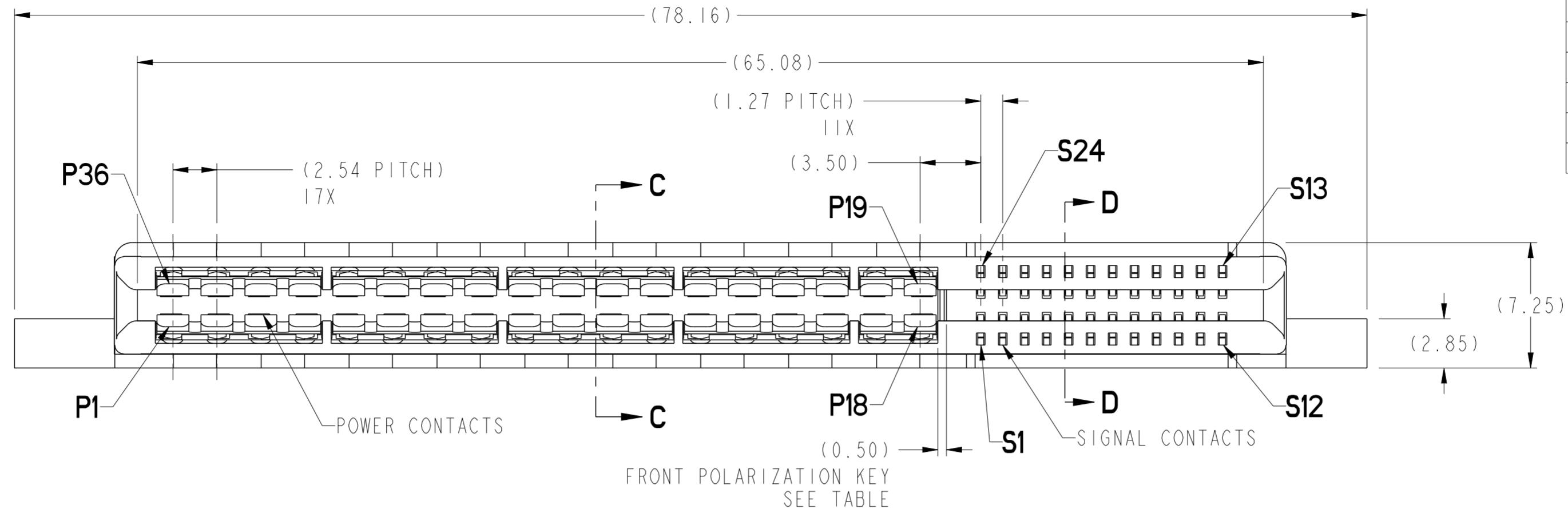

spec ref	-	dr	Wei-Long Zhang	2011/08/30	projection	MM	size	A2	scale	4:1						
tolerance std	ASME Y14.5	eng	Wei-Long Zhang	2011/09/13			CARD EDGE	rel level	Released	rev						
TOLERANCES UNLESS OTHERWISE SPECIFIED		chr	Jon Qin	2011/09/13							ecn no	-				
surface	linear	0.X	±0.30													
	0.XX	±0.10														
	0.XXX	±0.05														
ASME Y14.5	angular	0°	±2°	www.fci.com	cat. no.	-	Product - Customer Drw	sheet 1 of 5								

Copyright FCI. FCI

NEW RECOMENDED HOST BOARD LAYOUT FOR IMPROVED SOLDER REFLOW PROCESS

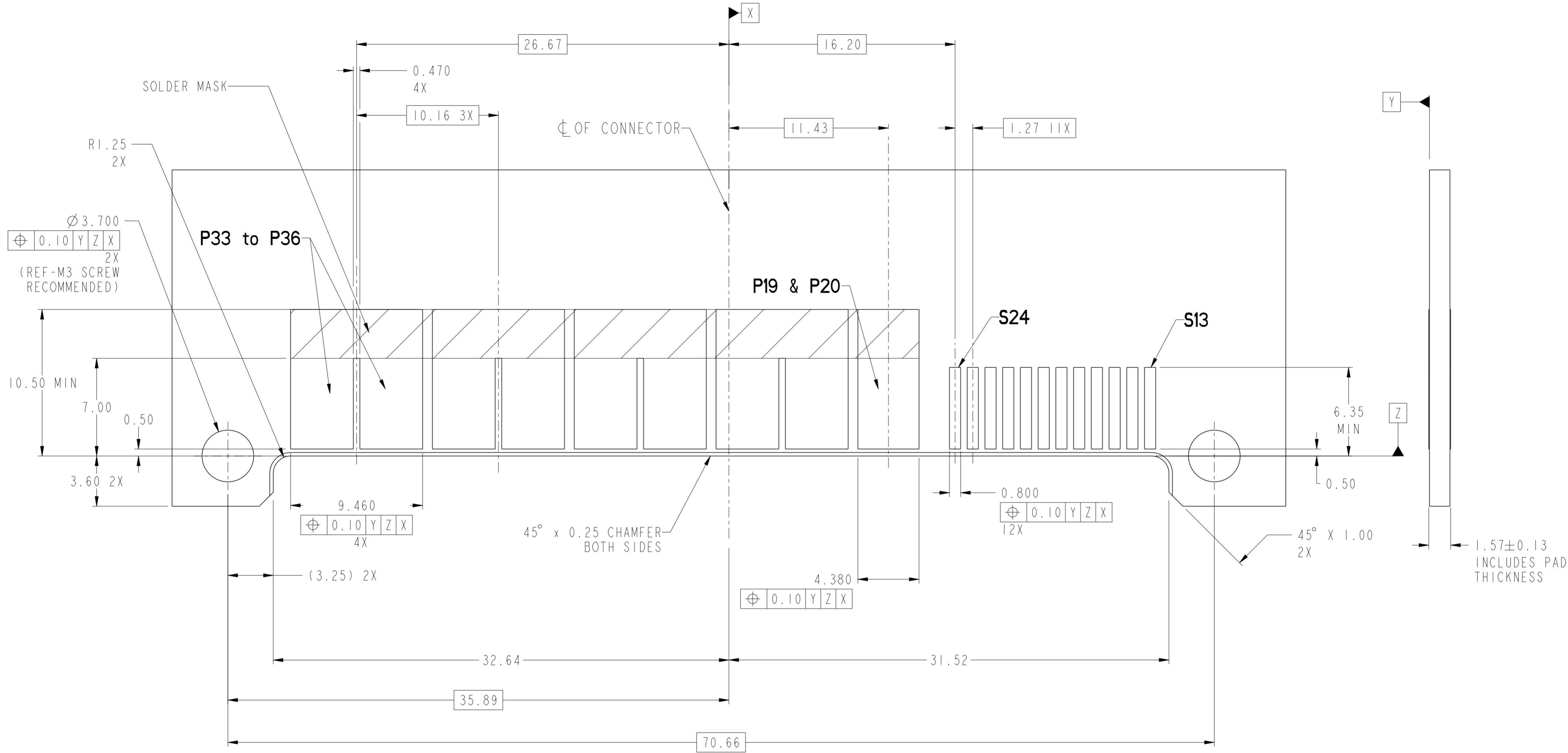

HOST BOARD LAYOUT AS VIEWED

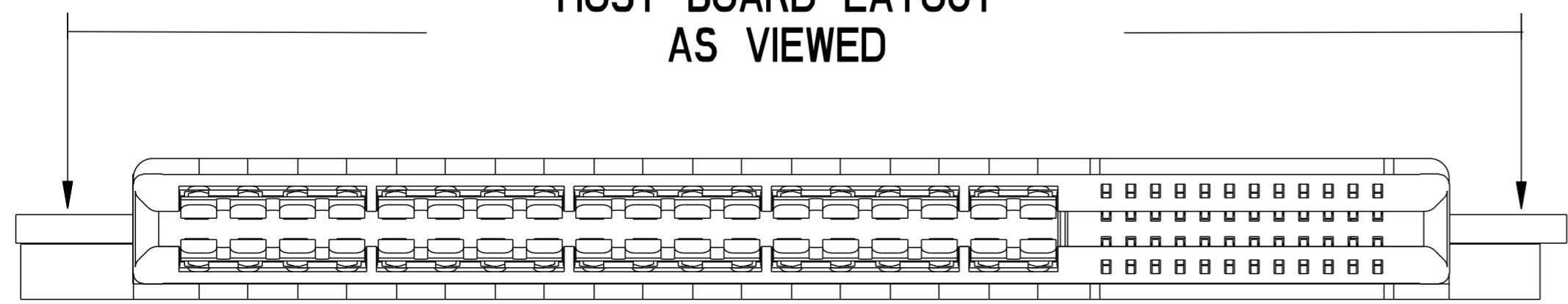

SCALE 7:2

spec ref	-	dr	Wei-Long Zhang	2011/08/30	projection	MM	size	A2	scale	4:1
tolerance std	ASME Y14.5	eng	Wei-Long Zhang	2011/09/13		CARD EDGE	ecn no	-	rel level	Released
TOLERANCES UNLESS OTHERWISE SPECIFIED		chr	Jon Qin	2011/09/13			product family	HPCE-STADDLE MT (36P-24S)		10118966
surface	✓	appr	Pei-Ming Zheng	2011/09/13	www.fci.com	cat. no.	-	Product - Customer Drw	sheet 2 of 5	
ASME Y14.5	linear	0.X	±0.30	0.XX	±0.10	0.XXX	±0.05	angular	0°	±2°

PDS: Rev :A

STATUS:Released

Printed: Sep 13, 2011

Copyright FCI. FCI

OLD RECOMENDED HOST BOARD LAYOUT

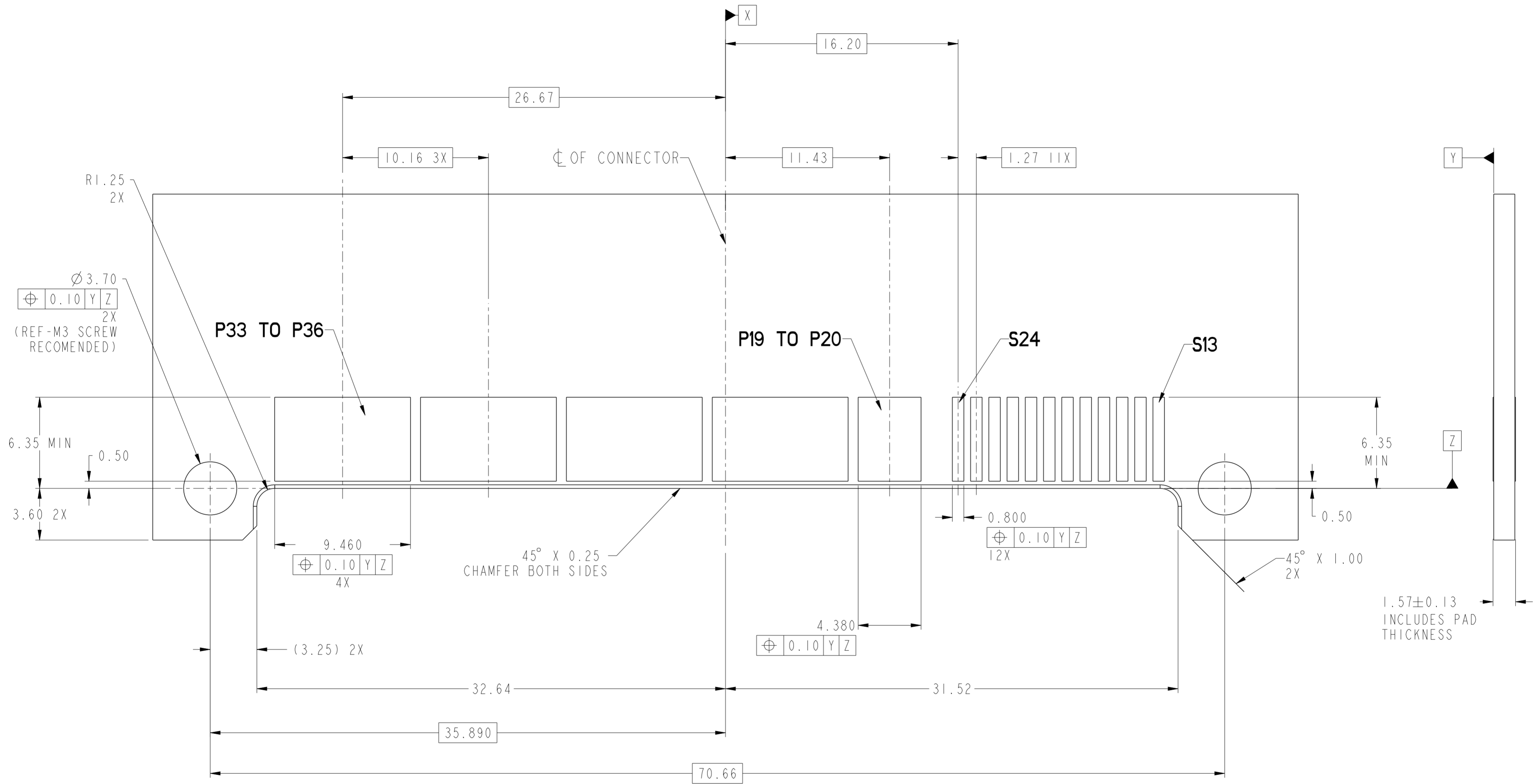

Copyright FCI.
FCI

spec ref	-	dr	Wei-Long Zhang	2011/08/30	projection	MM	size	A2	scale	4:1
tolerance std	ASME Y14.5	eng	Wei-Long Zhang	2011/09/13		CARD EDGE	rel level	Released	ecn no	-
TOLERANCES UNLESS OTHERWISE SPECIFIED		chr	Jon Qin	2011/09/13						
surface	ASME Y14.5	appr	Pai-Ming Zheng	2011/09/13	product family	HPCE-STRADDLE MT (36P-24S)	dwg no	10118966	rev	A
	linear	0.X	±0.30		(RECEPTACLE) SPECIAL CASE		Product - Customer Drw		sheet 3 of 5	
		0.XX	±0.10		cat. no.		STATUS:Released		Printed: Sep 13, 2011	
	angular	0°	±2°		PDS: Rev :A		STATUS:Released		Printed: Sep 13, 2011	

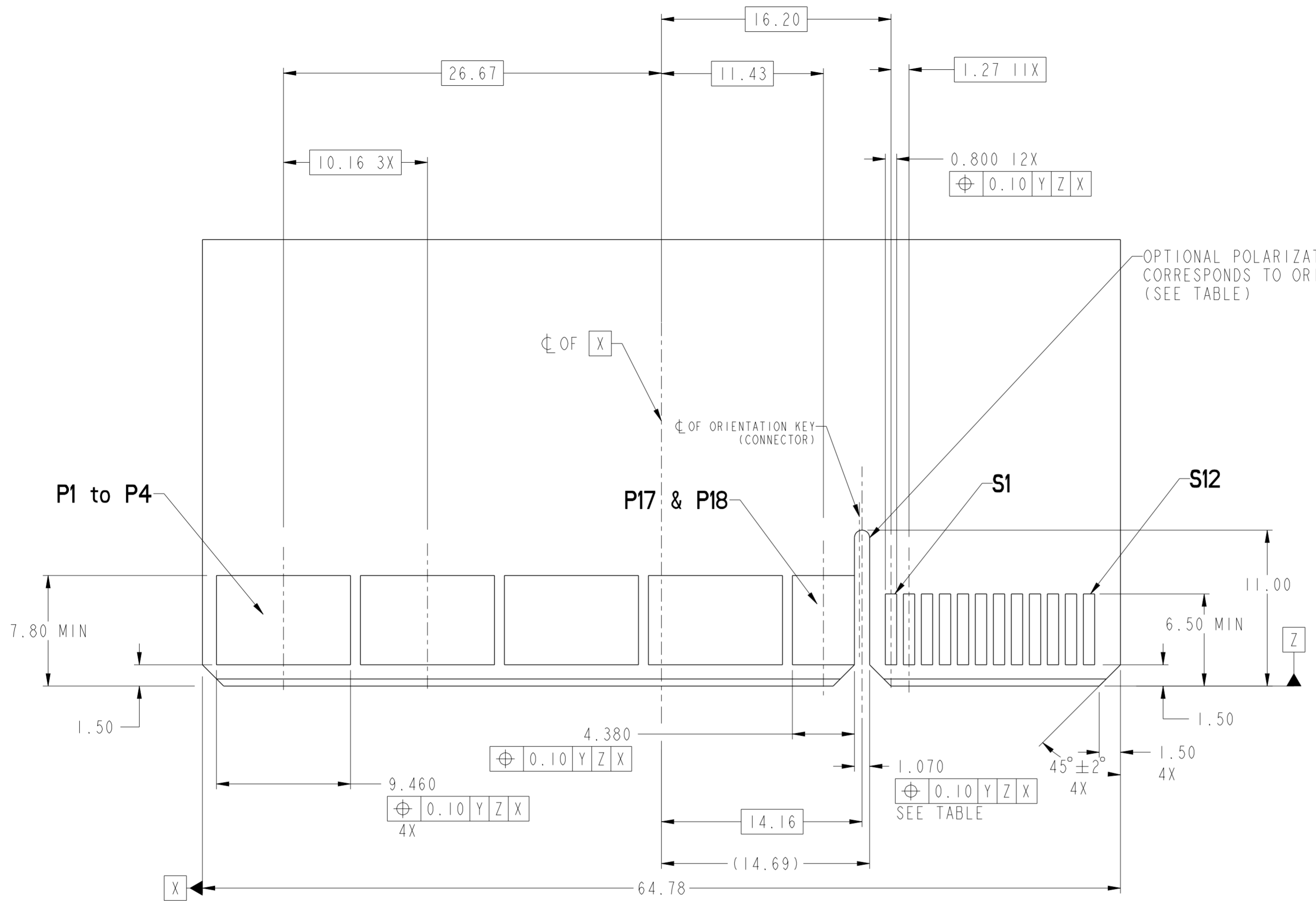

OPTIONAL POLARIZATION SLOT
CORRESPONDS TO ORIENTATION KEY OPTION
(SEE TABLE)

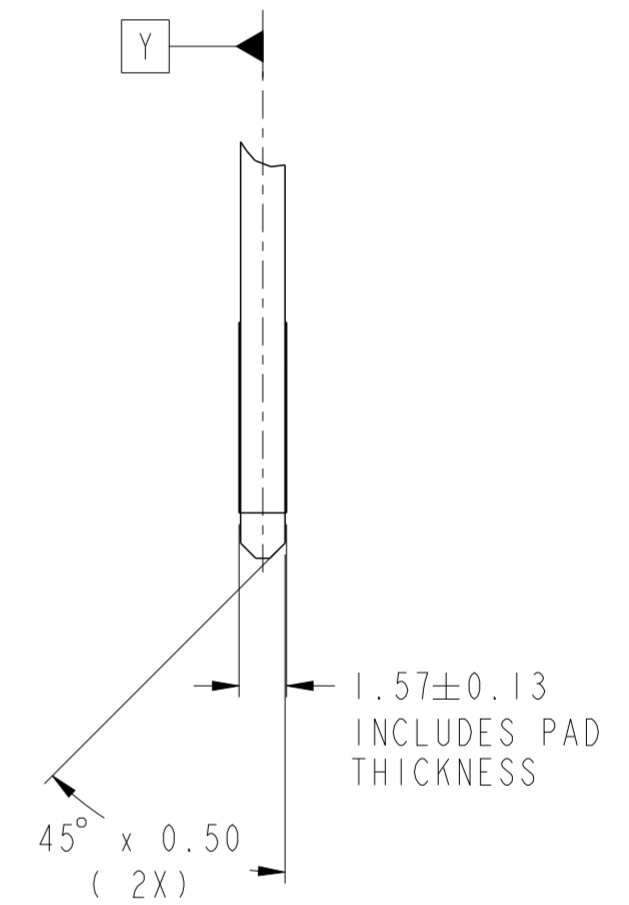

RECOMMENDED MATING BOARD FOOTPRINT

Copyright FCI.
FCI

spec ref	-	dr	Wei-Long Zhang	2011/08/30	projection	MM	size	A2	scale	4:1
tolerance std	ASME Y14.5	eng	Wei-Long Zhang	2011/09/13			ecn no	-	rel level	Released
TOLERANCES UNLESS OTHERWISE SPECIFIED		chr	Jon Qin	2011/09/13						
surface	ASME Y14.5	appr	Pai-Ming Zheng	2011/09/13	product family	CARD EDGE	dwg no	10118966	rev	A
linear	0.X ±0.30 0.XX ±0.10 0.XXX ±0.05	www.fci.com		cat. no.	-		Product - Customer Drw		sheet 4 of 5	
angular	0° ±2°	PDS: Rev :A		STATUS:Released		Printed: Sep 13, 2011				

PART NUMBER	FEATURE A MOUNTING EARS	FEATURE B FRONT POLARIZATION KEY
10118966-001LF	YES	YES
10118966-002LF		NO

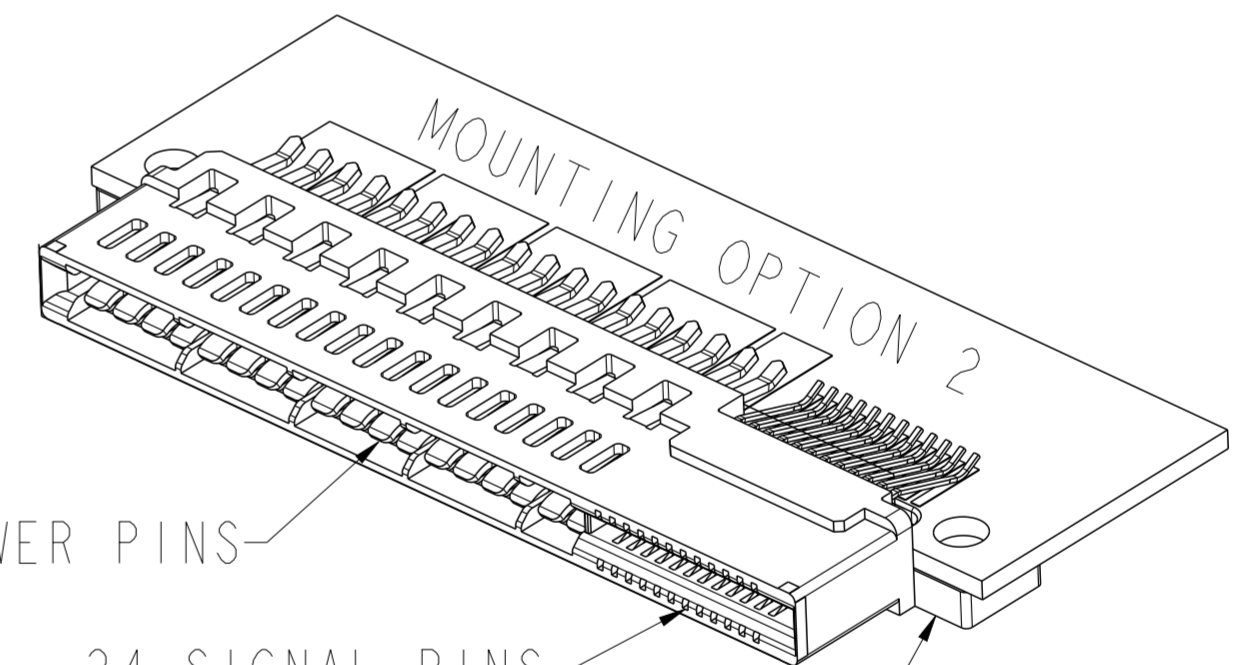
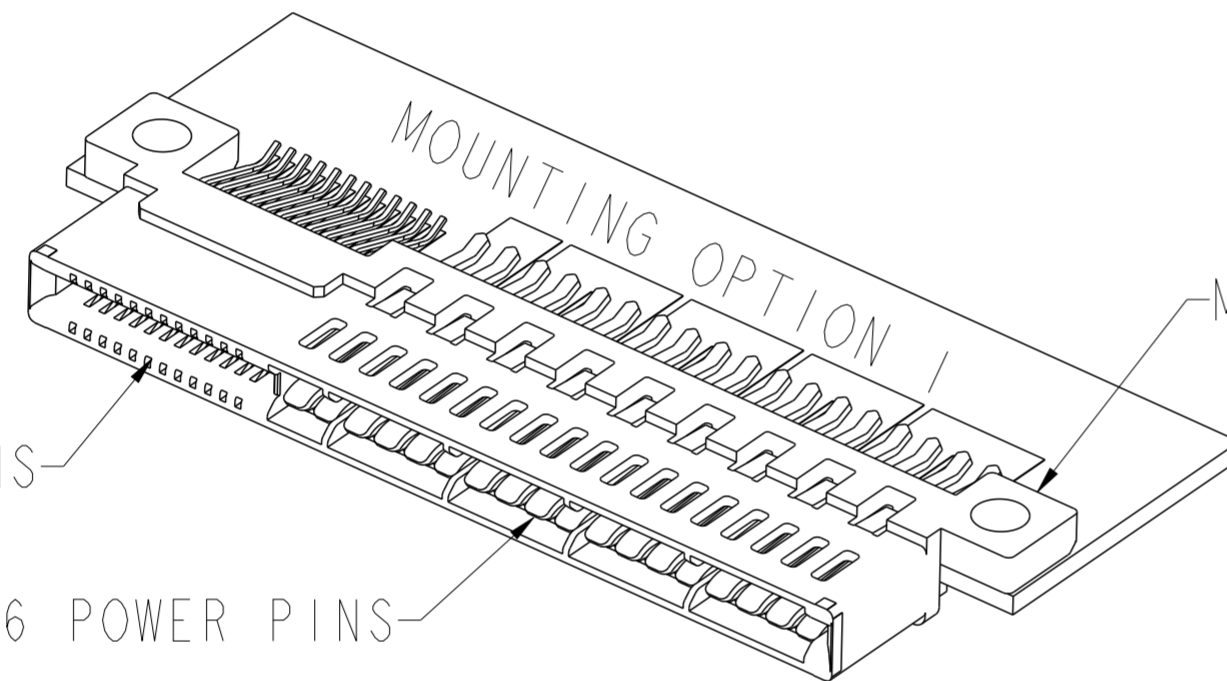
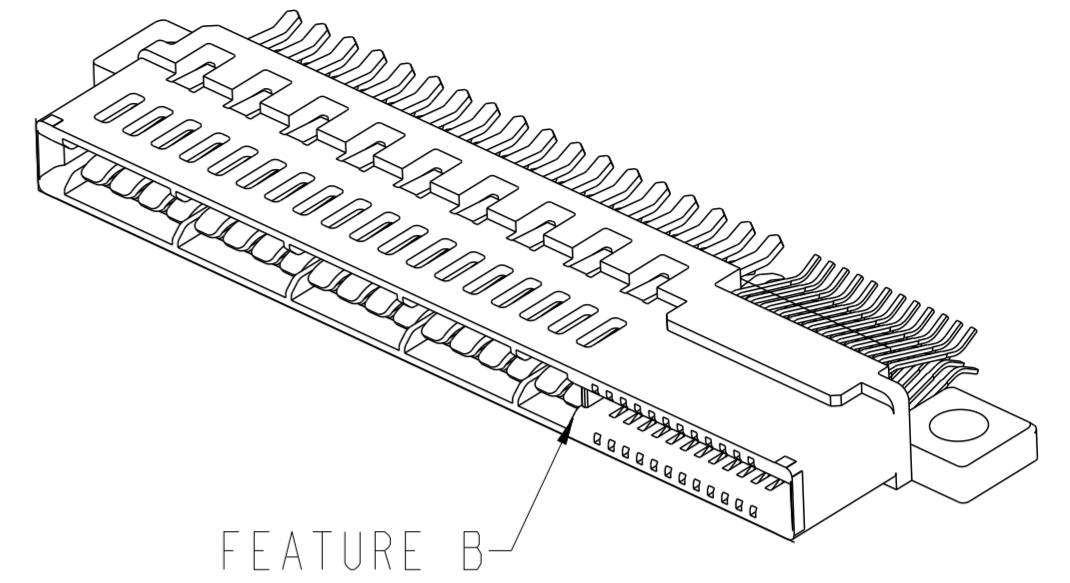
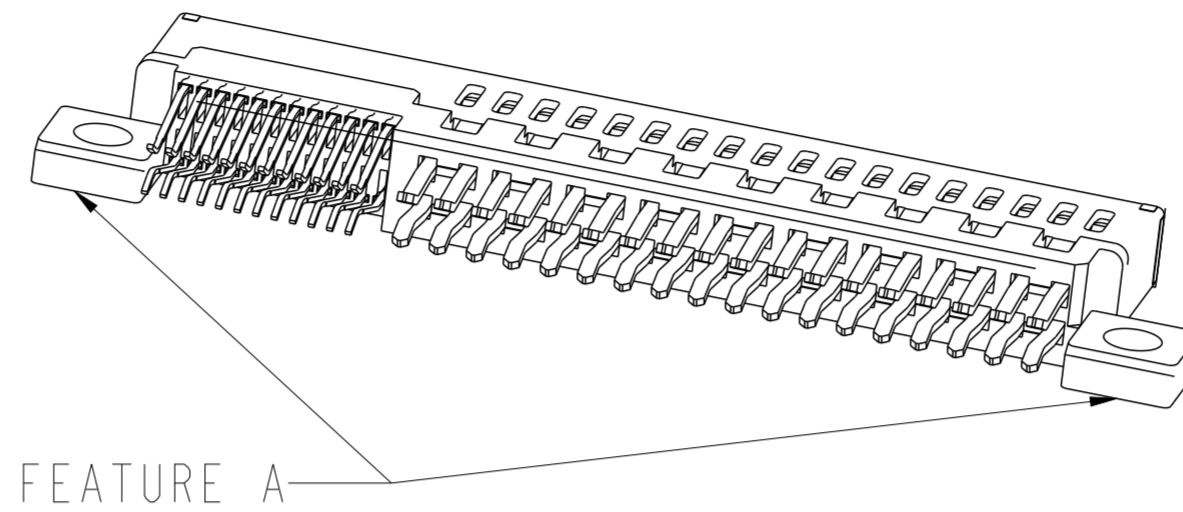

NOTES:

- CONNECTOR MATERIALS:
HOUSING: HIGH TEMPERATURE THERMAL PLASTIC, BLACK
UL 94V-0 COMPLIANT
CONTACTS: HIGH PERFORMANCE COPPER ALLOY.
- CONTACT FINISH REF. GS-12-604 SECTION 5.2.
- PRODUCT SPECIFICATION: GS-12-604.
- APPLICATION SPECIFICATION: GS-20-128.
- PRODUCT MARKING (FCI - PART NUMBER & DATE CODE) ON HOUSING IN AREA SHOWN.
- PACKAGING MEETS FCI SPECIFICATION GS-14-937.
- HOUSING COMPONENT WILL WITHSTAND EXPOSURE TO 260°C PEAK TEMPERATURE FOR 60 SECONDS IN A CONVECTION, INFRA-RED, OR VAPOR PHASE REFLOW OVEN.
- HOST BOARD ALIGNMENT KEY IS RECOMMENDED TO ENSURE PROPER ALIGNMENT OF SOLDER TAILS WITH HOST BOARD PADS.
- THE OLD RECOMENDED BOARD IS ASSOCIATED WITH -001 & -002 PARTS. THE NEW HOST BOARD CAN BE USED WITH ALL DASH NUMBERS AND IS FOR IMPROVED SOLDER REFLOW PROCESS.

spec ref	-	dr	Wei-Long Zhang	2011/08/30	projection	MM	size	A2	scale	4:1												
tolerance std	ASME Y14.5	eng	Wei-Long Zhang	2011/09/13			ecn no	-	rel level	Released												
TOLERANCES UNLESS OTHERWISE SPECIFIED		chr	Jon Qin	2011/09/13																		
surface	<table border="1"> <tr> <td>linear</td> <td>0.X</td> <td>±0.30</td> </tr> <tr> <td></td> <td>0.XX</td> <td>±0.10</td> </tr> <tr> <td></td> <td>0.XXX</td> <td>±0.05</td> </tr> <tr> <td>angular</td> <td>0°</td> <td>±2°</td> </tr> </table>	linear	0.X	±0.30		0.XX	±0.10		0.XXX	±0.05	angular	0°	±2°	appr	Pai-Ming Zheng	2011/09/13	product family	CARD EDGE	part no	10118966	rev	A
linear	0.X	±0.30																				
	0.XX	±0.10																				
	0.XXX	±0.05																				
angular	0°	±2°																				
www.fci.com		cat. no.		-		Product - Customer Drw		sheet 5 of 5														