

13 12 11 10 9 8 7 6 5 4 3 2 1

J I H G F E D C B A

INCLUDES:
REDUCERS FOR 3/4" AND 1/2" CONDUIT
AND PLUGS FOR UNUSED HOLES.

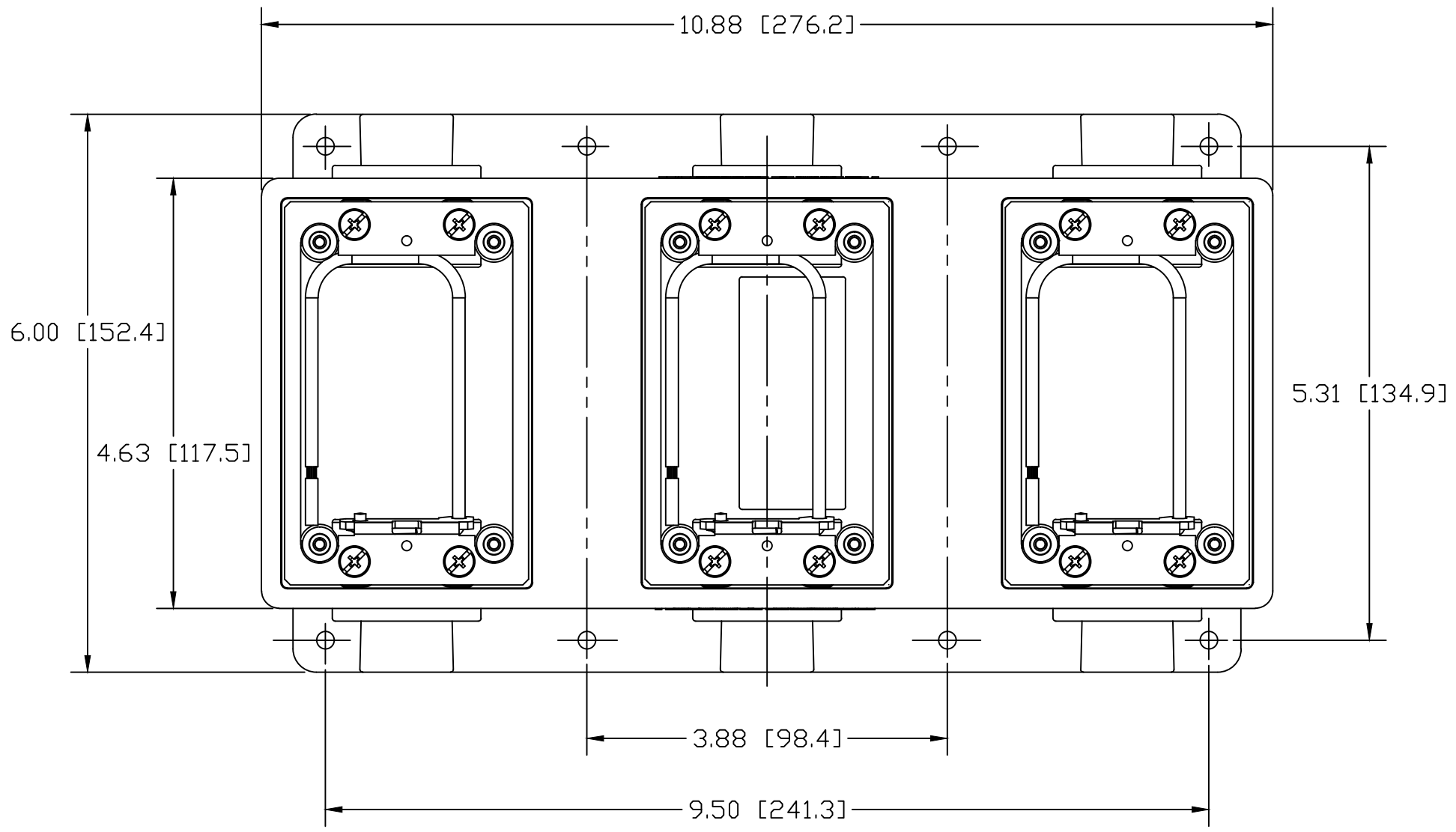

- STAINLESS STEEL MOUNTING PLATE
- GROUNDING WIRE
- PVC FRAME
- TPV GASKET
- PVC BOX

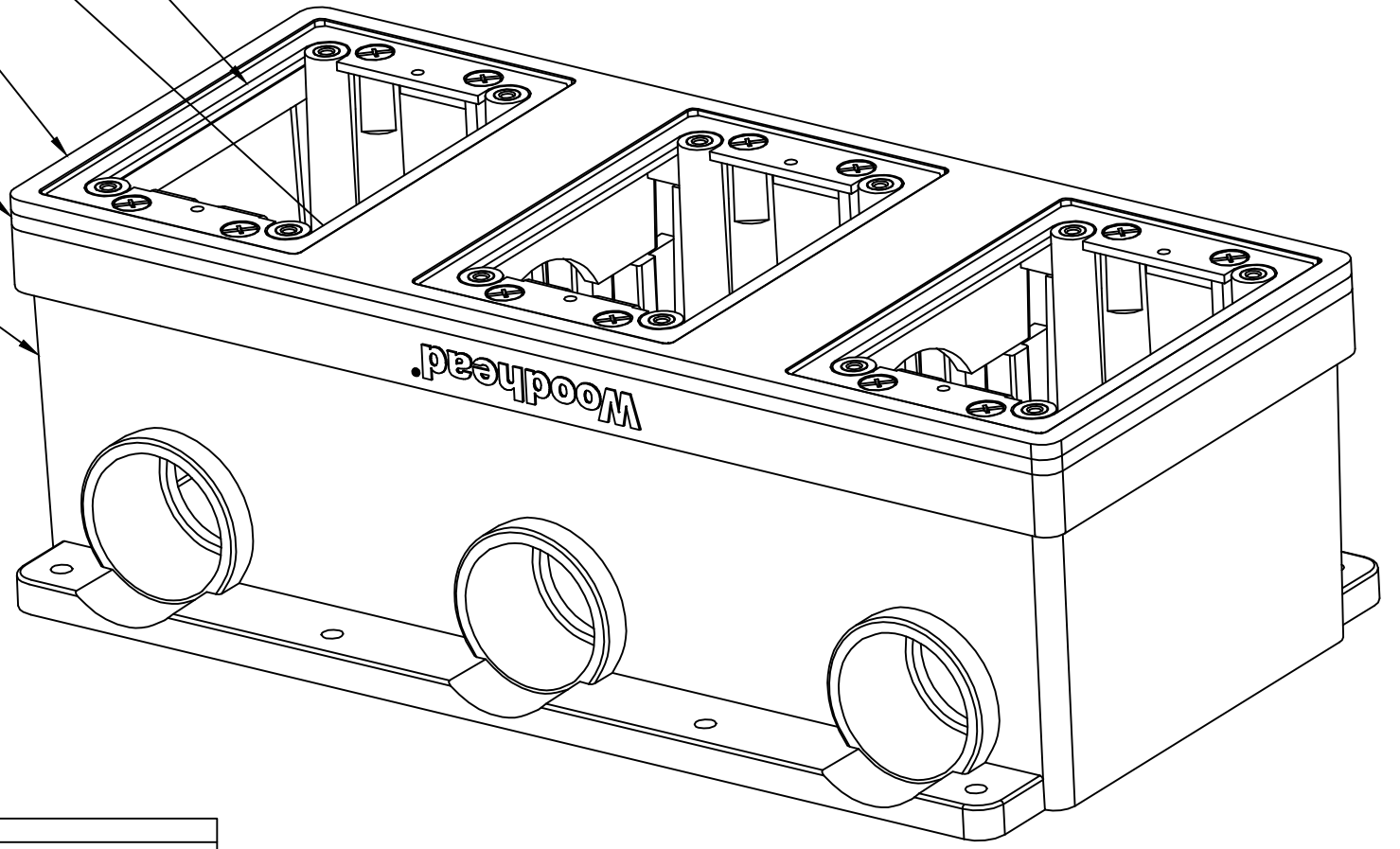
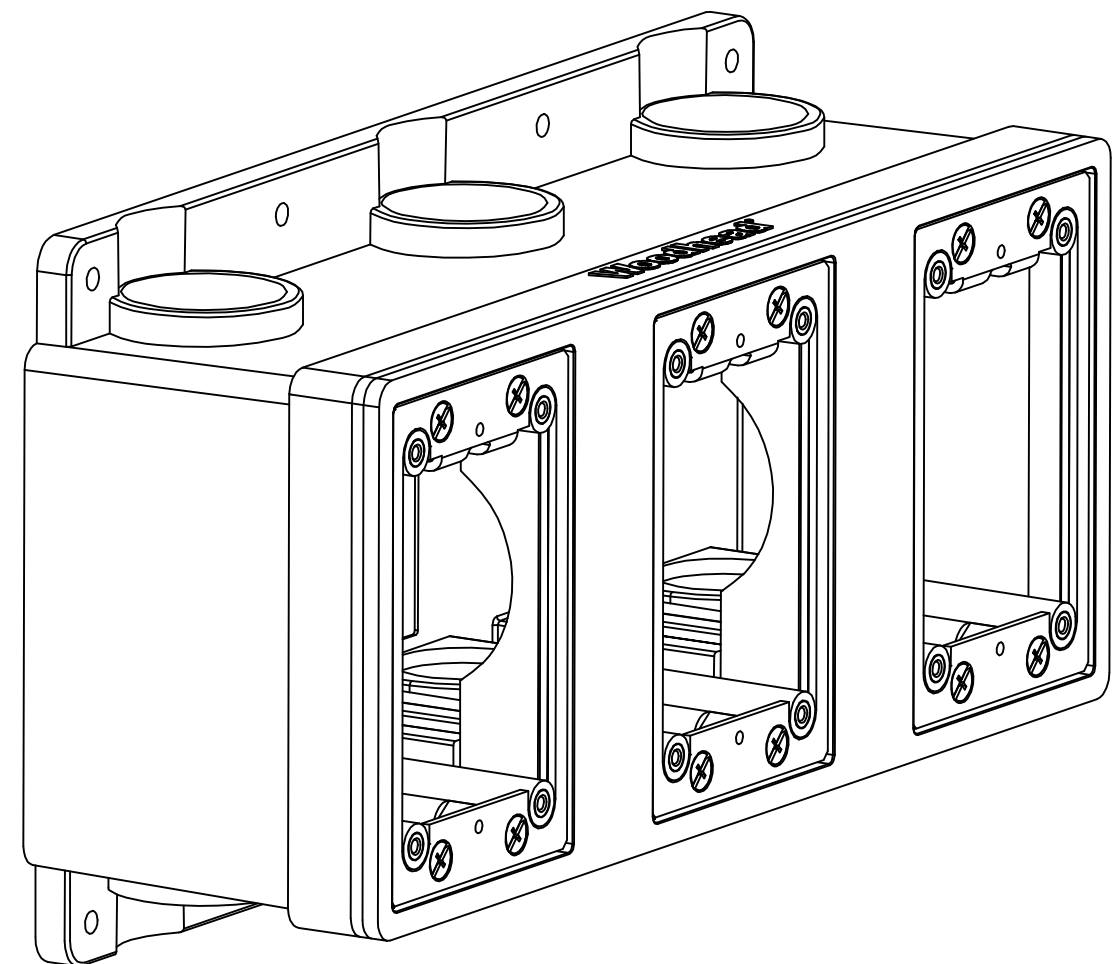

1" DIAMETER UNTHREADED
CONDUIT OPENINGS, 6 PLACES

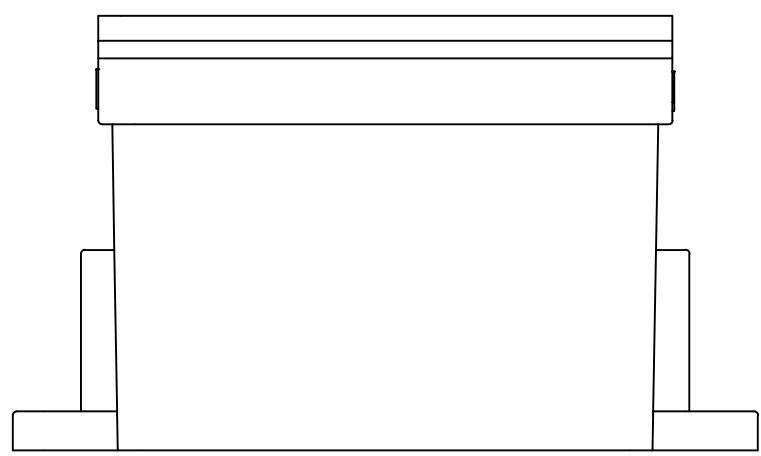
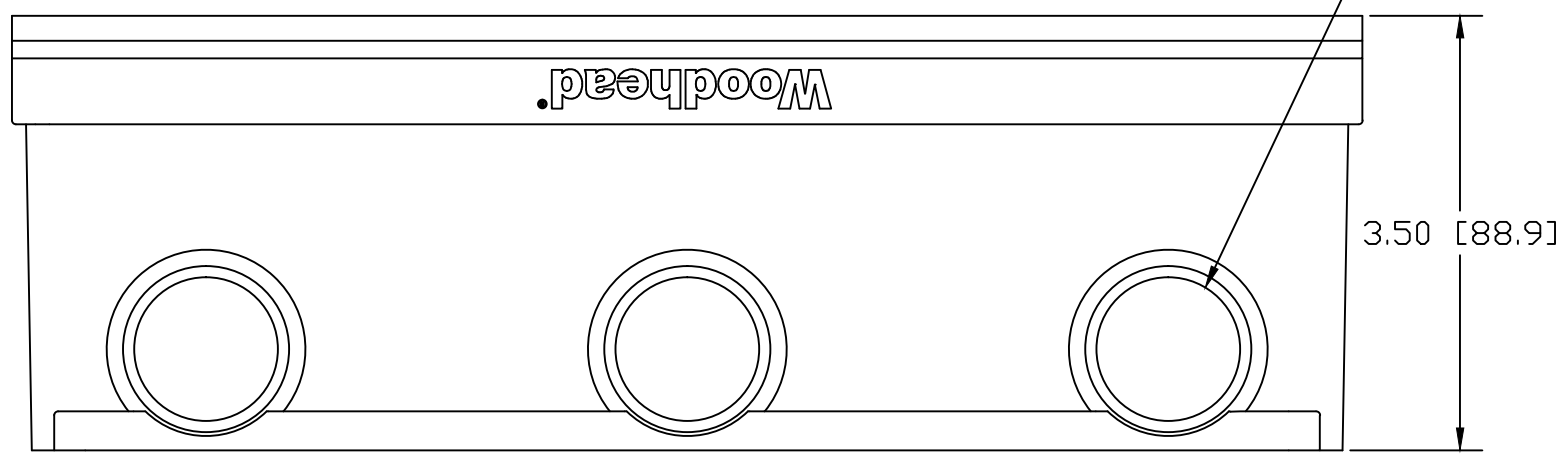

MATERIAL #	ENGINEERING #	COLOR
1301280152	455-FD3	YELLOW
1301280162	455-FD3BLK	BLACK

RELEASE DRAWING EC NO: IFC2014-0796 DRWN: HKNEELAN 2013/11/01 CHKD: HKNEELAN APPR: JFMURPHY 2013/11/08	QUALITY SYMBOL	GENERAL TOLERANCES (UNLESS SPECIFIED)	DIMENSION STYLE INCH[MM]	SCALE NTS	DESIGN UNITS INCH	THIRD ANGLE PROJECTION
	▽=0	4 PLACES ±--- ±---	DRAWN BY DATE	TITLE	FD BOX, 3 GANG FOR WATERTITE	
	∇=0	3 PLACES ±--- ±.005	CHECKED BY DATE			
		2 PLACES ±0.10 ±.010	APPROVED BY DATE	MOLEX INCORPORATED		
	1 PLACE ±0.25 ±.020	MATERIAL NO.	DOCUMENT NO. SD-130128-003			
		ANGULAR ±.5°	SHEET NO. 1 OF 1			
		DRAFT WHERE APPLICABLE MUST REMAIN WITHIN DIMENSIONS	THIS DRAWING CONTAINS INFORMATION THAT IS PROPRIETARY TO MOLEX INCORPORATED AND SHOULD NOT BE USED WITHOUT WRITTEN PERMISSION			
A	REV		SIZE C			

13 12 11 10 9 8 7 6 5 4 3 2 1