



ANATECH ELECTRONICS INC
RF & Microwave Filters & Products

5100 MHz LC Bandpass Filter

Part Number: AE5100B6448



Electrical Specifications

Center Frequency: 5100 MHz
Passband: <1 @ 4933 MHz to 5268 MHz
VSWR: 1.5:1
Insertion Loss: <3 dB @ 4933 MHz to 5268 MHz
Impedance: 50 Ohms
Rejection: > 70 dB @ 4700 MHz

Mechanical

Mounting Method: Through Holes
Dimensions: 1.25" X 0.38" x 0.38" in.

Environmental

Operating Temperature: -25°C to +70°C
Storage Temperature: -40°C to +90°C
Shock: 10 G. 11ms
Vibration: 10 G. 5 to 200Hz

Outline Drawing:

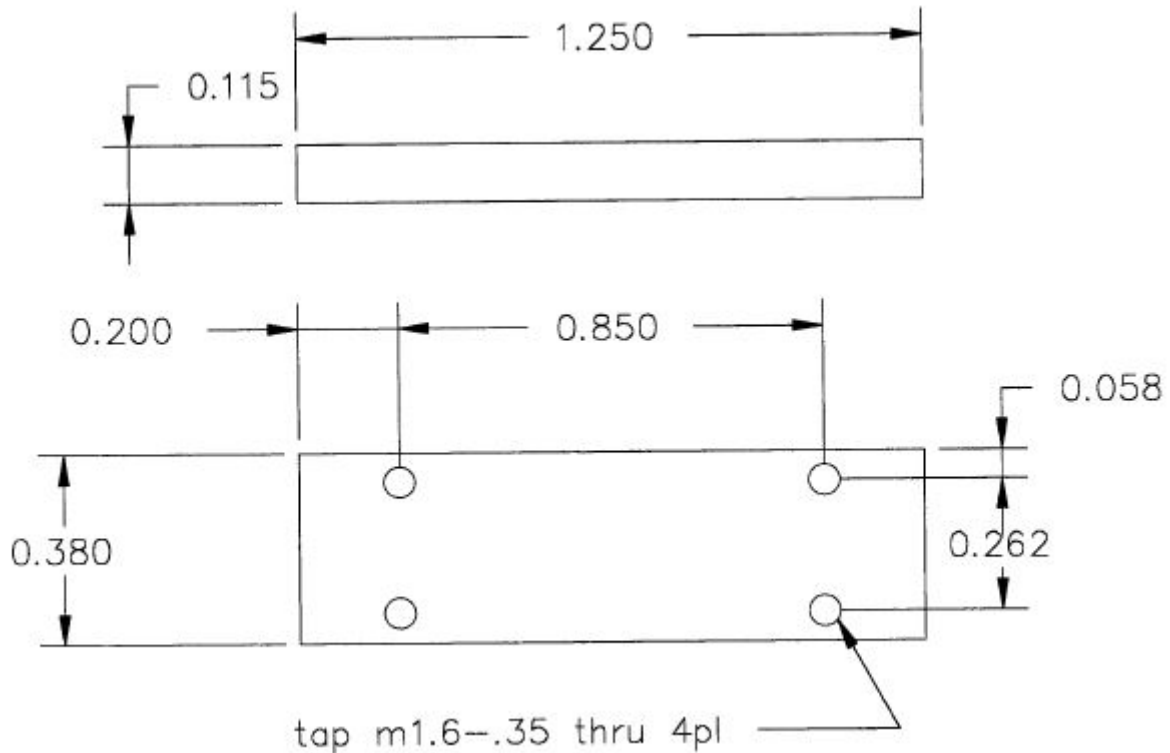



Response Plot:

Freq. (MHz)	ATT (dB)	SPEC	Flatness
4700	70.175	70	
4925	3.10	(0.5)	0.79
5100	2.30	3	0.00
5275	3.16	(0.5)	0.86

