

SPECIFICATION CONTROL DRAWING

7526K5424

CHEMINAX

75 OHM, AWG 26, 7 STRANDS OF AWG 34, TRIAXIAL CABLE

Date: 8-30-16
Revision: B

THIS SPECIFICATION SHEET FORMS A PART OF THE LATEST ISSUE OF RAYCHEM SPECIFICATION 1200.

CONSTRUCTION DETAILS

ELECTRICAL CHARACTERISTICS

DIMENSIONS ARE NOMINAL VALUES IN INCHES, UNLESS OTHERWISE DESIGNATED.

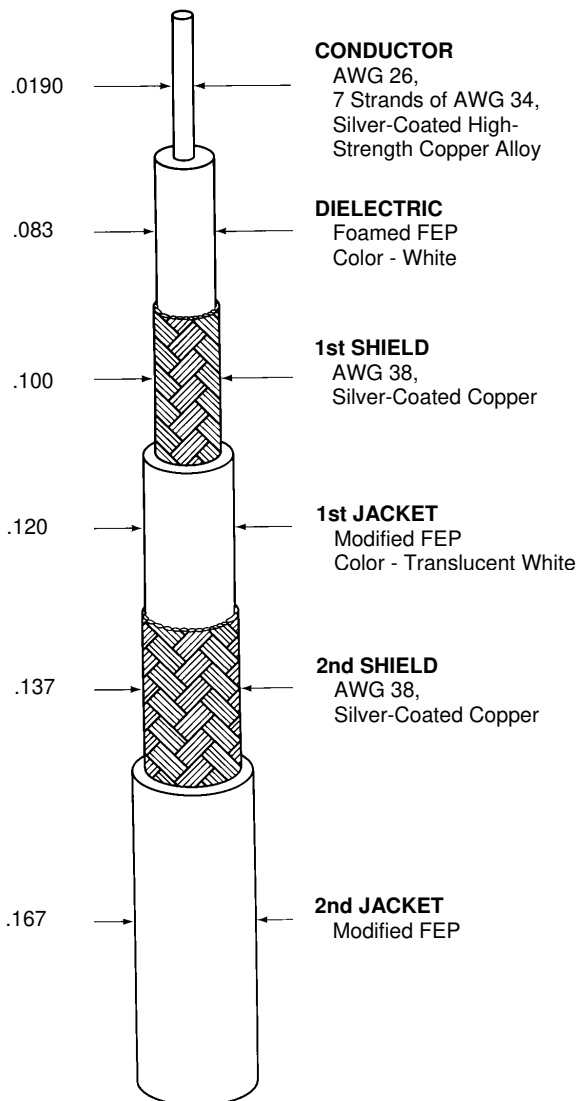

CHARACTERISTIC IMPEDANCE	75 ± 3 ohms, Method B
CAPACITANCE	17.6 pF/ft. (nominal)
VELOCITY OF PROPAGATION	77% (nominal)

ADDITIONAL REQUIREMENTS

ELECTRICAL

CONDUCTOR RESISTANCE	43.9 ohms/1000 ft. (nominal)
INSULATION RESISTANCE CONDUCTOR TO SHIELD	10,000 megohms (minimum) for 1000 ft.
JACKET FLAWS SPARK TEST IMPULSE TEST	1.0 kV (rms) 6.0 kV (peak)
VOLTAGE WITHSTAND CONDUCTOR TO SHIELD SHIELD TO SHIELD	1000 volts (rms) (minimum) 500 volts (rms) (minimum)

ENVIRONMENTAL

FLAMMABILITY	Method B
HEAT SHOCK	225°C
LOW TEMPERATURE-COLD BEND	-55°C/4.50 inch mandrel
UV LASER MARKING (per SAE AS4373, Method 1001)	For 7526K5424-9LM only:
SOLID LASER	67% (minimum)
DOT MATRIX LASER	60% (minimum)
VOLTAGE WITHSTAND (Post Environmental)	1000 volts (rms), 1 minute

PHYSICAL

INSULATION (DIELECTRIC) ELONGATION TENSILE STRENGTH	50% (minimum) 600 lbf/in ² (minimum)
JACKET (each) ELONGATION TENSILE STRENGTH	200% (minimum) 2000 lbf/in ² (minimum)
JACKET THICKNESS 1st JACKET 2nd JACKET	.010 inch (nominal) .015 inch (nominal)
SHIELD COVERAGE (each)	90% (minimum)
WEIGHT	25.9 lbs/1000 ft. (nominal)

ENGINEERING REFERENCE

TEMPERATURE RATING	200°C (maximum)
--------------------	-----------------

Designate outer jacket color with a dash number in accordance with MIL-STD-681. Unless otherwise specified, outer jacket color will be translucent white designated by a "-9X" appended to the part number, e.g. 7526K5424-9X.

A white laser markable outer jacket will be designated by a "-9LM" appended to the part number, e.g. 7526K5424-9LM.

Other codes and suffixes may be added to the part number, as necessary, to capture any additional requirements imposed by the purchase order.

Users should evaluate the suitability of this product for their application. Specifications are subject to change without notice. Tyco Electronics Corporation also reserves the right to make changes in materials or processing, which do not affect compliance with any specification, without notification to Buyer.

