

DESCRIPTION

Demonstration circuit DC930 is a single Li-ion cell/battery stand-alone battery charge controller with built in charge termination featuring the LTC4001. The input voltage is 4.3 to 5.5V. The charger output voltage is fixed for a 1cell 4.2V Li-ion battery. The maximum charge current is 2A. The board will automatically charge a battery to termination as soon as input power is applied with a battery connected prior to power up. Status LEDs are provided for CHARGE, FAULT and C/10. An onboard NTC thermistor is provided. Jumpers are provided to reduce both charge cur-

rent and charge detection threshold down to 1A and 0.1A respectively. An on-off and an external-onboard thermistor jumper are also provided. The board is laid out to support remote voltage sensing at both input and output terminals. Test-points are provided for various signal-monitoring points.

Design files for this circuit board are available. Call the LTC factory.

 , LTC and LT are registered trademarks of Linear Technology Corporation.

Table 1. Performance Summary

PARAMETER	CONDITION	VALUE
Maximum Input Voltage	Limited by IC Volt Ratings.	5.5V
Recommended Minimum Input Voltage	$V_{in} > V_{bat}$ Termination voltage + 100mV.	4.3V (4.5V recommended)
Charge Time	$C3 = 0.1\mu F$, where $C3 = \text{Time} * 0.0733\mu F/\text{Hr}$ Time can be increased by adding parallel cap between timer test point and ground.	1.3 Hours +/- 10%
Automatic Recharge Threshold		$V_{bat} < 4.1V$
Efficiency	$V_{in} = 5V$, $V_{bat} = 4V$ and $I_{bat} = 2Amps$	>85%
Maximum Charge Current	Default is set up for 2A. 1A jumper provided.	2A +/- 5%

QUICK START PROCEDURE

- 1) Connect the input power source to PVIN and GND terminals (TP1 and TP2) using a power supply capable of handling a minimum of 2.5A of current within a 4.5 to 5.5V range. The input supply MUST be greater than the full voltage value of the battery to allow a full charge to take place.
- 2) Connect the load to BAT+ and BAT- terminals (TP8 and TP5).
- 3) Connect a 4.2V Li-ion battery to the terminals.
- 4) Turn on the input power supply.
- 5) NOTE: If the board is allowed to get to warm, the onboard NTC thermistor may trip and momentarily suspend the charge process. The Fault LED being activated can confirm this. When the board cools down, charging will automatically resume.
6. NOTE: Resistive based current monitoring meters placed in series with the chargers output will lengthen the charge time. Any increase in series resistance will force the CC to CV transition point to occur prematurely such that the CV phase will become longer than normal relative to a direct battery connection. Total charge time will also increase.

QUICK START GUIDE FOR DEMONSTRATION CIRCUIT DC930A

1 CELL LI-ION BATTERY CHARGER BOARD WITH BUILT IN CHARGE TERMINATION

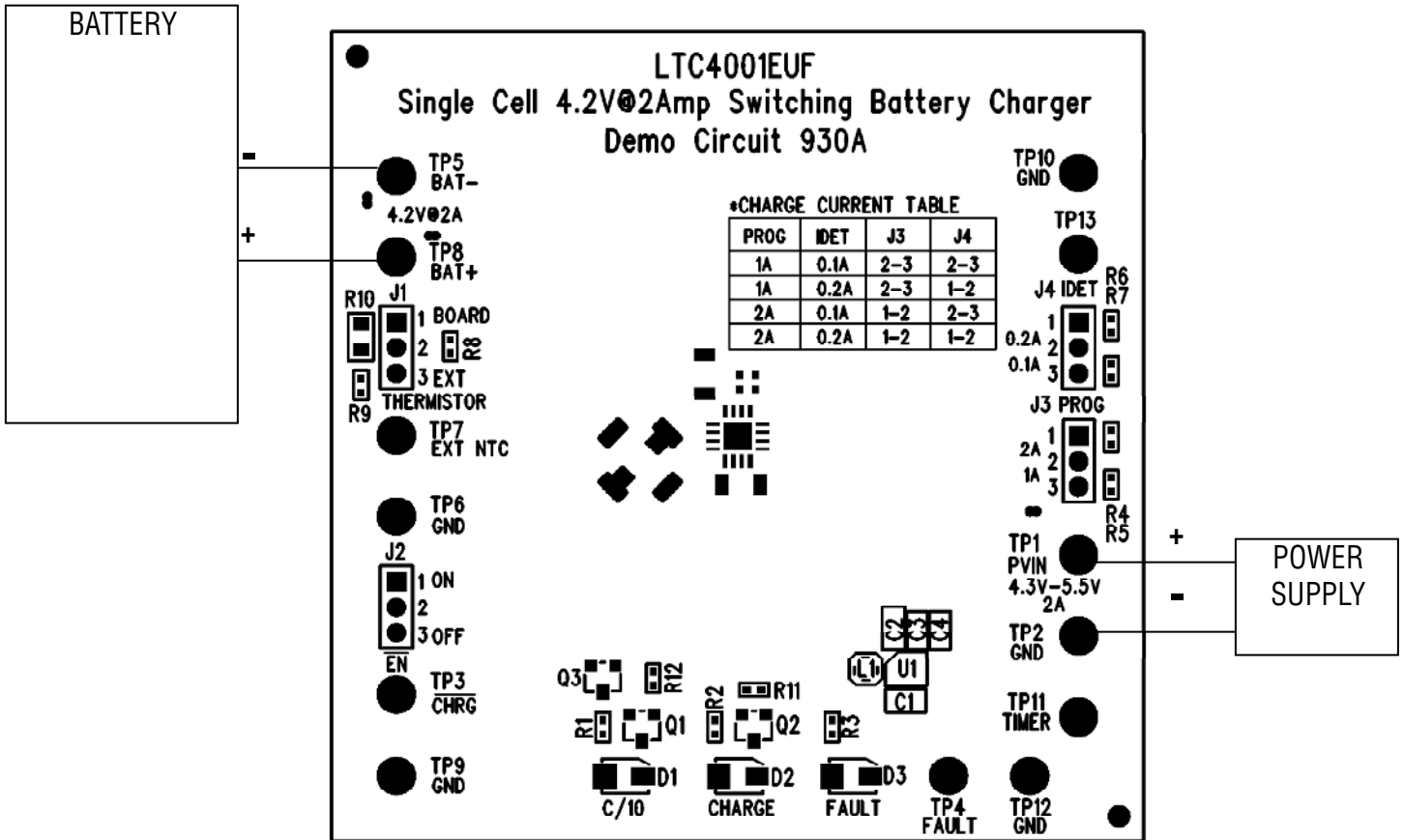

QUICK START GUIDE FOR DEMONSTRATION CIRCUIT DC930A 1 CELL LI-ION BATTERY CHARGER BOARD WITH BUILT IN CHARGE TERMINATION

