

DO NOT SCALE FROM THIS PRINT

DESIGNED & DIMENSIONED IN MILLIMETERS [INCHES]

DIN7A-PP-C-XX-ST-CA3-X

- SERIES**
7A: 75 OHM DIN 1.0/2.3
- STYLE**
-P: PUSH PULL
- GENDER**
-P: PLUG
- TYPE**
-C: CABLE
- PACKAGING**
-BLANK: INDIVIDUALLY BAGGED
-B: BULK PACKAGE (QTY=100 MAX)
- TERMINATION**
-CA3: CABLE (RG179)
- ORIENTATION**
-ST: STRAIGHT
- PLATING SPECIFICATION**
-GF: GOLD/FLASH GOLD/NICKEL
10µ" AU / 50µ" NI MIN ON CENTER CONTACT,
3µ" AU / 50µ" NI MIN ON OUTER CONTACT,
100µ" NI MIN OTHER
-GG: GOLD/GOLD/NICKEL
10µ" AU / 50µ" NI MIN ON CENTER CONTACT,
10µ" AU / 50µ" NI MIN ON OUTER CONTACT,
100µ" NI MIN OTHER
-HH: HEAVY GOLD/HEAVY GOLD/NICKEL
30µ" AU / 50µ" NI MIN ON CENTER CONTACT,
30µ" AU / 50µ" NI MIN ON OUTER CONTACT,
100µ" NI MIN OTHER
-HF: HEAVY GOLD/FLASH GOLD/NICKEL
30µ" AU / 50µ" NI MIN ON CENTER CONTACT,
3µ" AU / 50µ" NI MIN ON OUTER CONTACT,
100µ" NI MIN OTHER

(SEE TABLE 1)

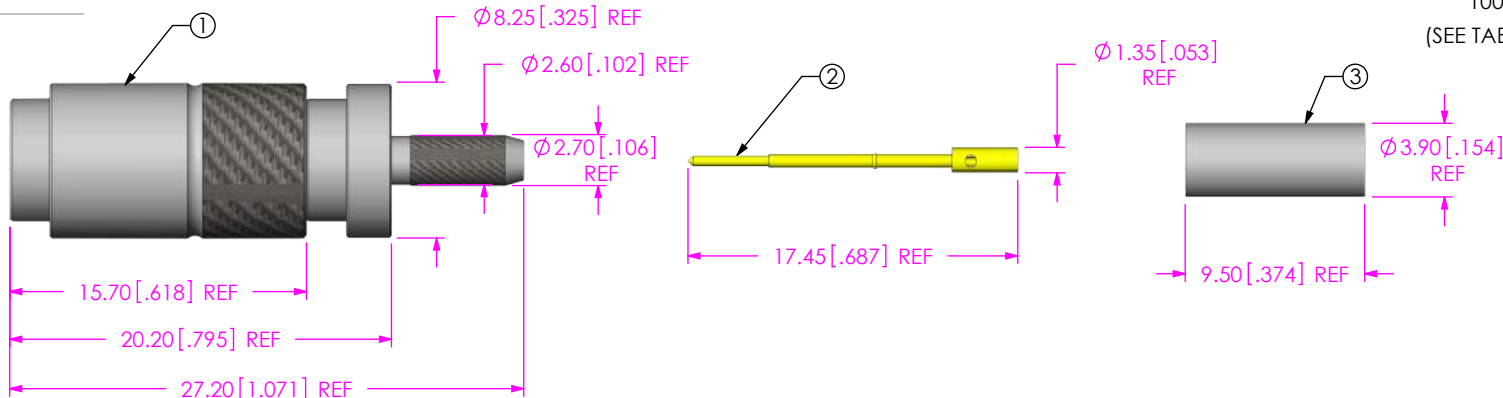

TABLE 1

ITEM	COMPONENT	-GF	-GG	-HH	-HF
1	SUB ASSEMBLY	SUB-DIN7A-PP-C-FN-ST-CA3	SUB-DIN7A-PP-C-GN-ST-CA3	SUB-DIN7A-PP-C-HN-ST-CA3	SUB-DIN7A-PP-C-FN-ST-CA3
2	PIN	DIN7A-P-C-G-ST-CA3-PIN		DIN7A-P-C-H-ST-CA3-PIN	
3	FERRULE	SMA-FER-001-N			

NOTES:

1. NOTE DELETED.
2. NOTE DELETED.
3. NOTE DELETED.
4. PRODUCT TO BE PACKAGED PER PRECISION RF SECTION OF PACKAGING MANUAL.
5. NOTE DELETED.
6. NOTE DELETED.
7. NOTE DELETED.

UNLESS OTHERWISE SPECIFIED, DIMENSIONS ARE IN MILLIMETERS [INCHES].

TOLERANCES ARE:
DECIMALS ANGLES
.X: ±0.3 [.01] 5°
.XX: ±0.13 [.005]
.XXX: ±0.051 [.0020]

PROPRIETARY NOTE

THIS DOCUMENT CONTAINS CONFIDENTIAL AND PROPRIETARY INFORMATION AND ALL DESIGN, MANUFACTURING, REPRODUCTION, USE, PATENT RIGHTS AND SALES RIGHTS ARE EXPRESSLY RESERVED BY SAMTEC, INC. THIS DOCUMENT SHALL NOT BE DISCLOSED, IN WHOLE OR PART, TO ANY UNAUTHORIZED PERSON OR ENTITY NOR REPRODUCED, TRANSFERRED OR INCORPORATED IN ANY OTHER PROJECT IN ANY MANNER WITHOUT THE EXPRESS WRITTEN CONSENT OF SAMTEC, INC.

MATERIAL: DO NOT SCALE DRAWING SHEET SCALE: 2:1

SHELL, FERRULE: BRASS
CONTACT: BRASS
GASKET: SILICONE
DIELECTRIC: PTFE



520 PARK EAST BLVD, NEW ALBANY, IN 47150
PHONE: 812-944-6733 FAX: 812-948-5047
e-Mail: info@SAMTEC.com code: 55322

DESCRIPTION:
TRUE 75 OHM, DIN 1.0/2.3 STRAIGHT PLUG, RG179

DWG. NO.
DIN7A-PP-C-XX-ST-CA3-X

BY: TALON Z 02/22/2010 SHEET 1 OF 3

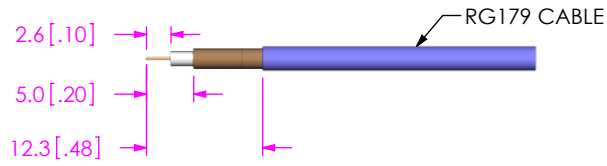

IN-PROCESS 1
STRIP CABLE AND TIN INNER
CONDUCTOR

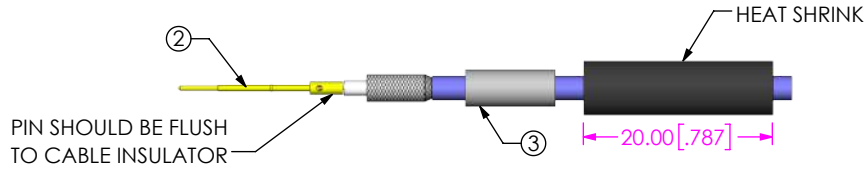

IN-PROCESS 2
ADD HEAT SHRINK & FERRULE
TO TUBING SOLDER SIGNAL PIN

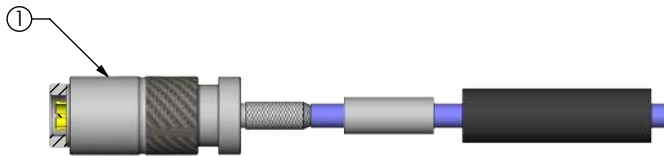

IN-PROCESS 3
FLARE SHIELD & ADD SUB ASSEMBLY

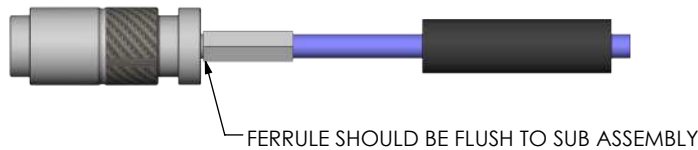

IN-PROCESS 4
CRIMP FERRULE
(USE RF CRIMP HAND TOOL #CAT-RF-FER-01)
(USE .128" HEX DIE)



IN-PROCESS 5
ACTIVATE HEAT SHRINK

PROPRIETARY NOTE
THIS DOCUMENT CONTAINS CONFIDENTIAL AND
PROPRIETARY INFORMATION AND ALL DESIGN,
MANUFACTURING, REPRODUCTION, USE, PATENT RIGHTS
AND SALES RIGHTS ARE EXPRESSLY RESERVED BY SAMTEC,
INC. THIS DOCUMENT SHALL NOT BE DISCLOSED, IN WHOLE
OR PART, TO ANY UNAUTHORIZED PERSON OR ENTITY NOR
REPRODUCED, TRANSFERRED OR INCORPORATED IN ANY
OTHER PROJECT IN ANY MANNER WITHOUT THE EXPRESS
WRITTEN CONSENT OF SAMTEC, INC.

DO NOT SCALE DRAWING

SHEET SCALE: 1.25:1



520 PARK EAST BLVD, NEW ALBANY, IN 47150
PHONE: 812-944-6733 FAX: 812-948-5047
e-Mail: info@SAMTEC.com code: 55322

DESCRIPTION:
TRUE 75 OHM, DIN 1.0/2.3 STRAIGHT PLUG, RG179

DWG. NO.
DIN7A-PP-C-XX-ST-CA3-X

BY: TALON Z 02/22/2010 SHEET 2 OF 3

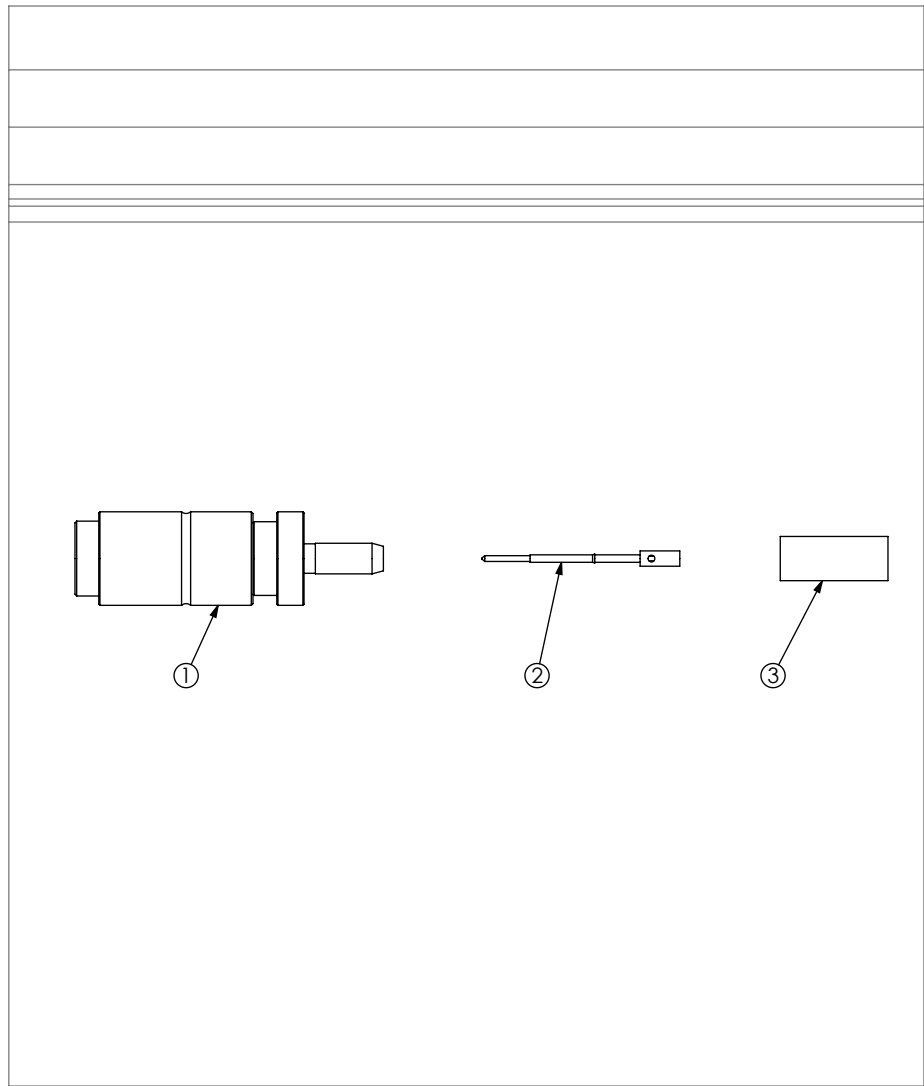

PACKAGING VIEW
DIN7A-PP-C-XX-ST-CA3 SHOWN

PROPRIETARY NOTE
 * THIS DOCUMENT CONTAINS CONFIDENTIAL AND PROPRIETARY INFORMATION AND ALL DESIGN, MANUFACTURING, REPRODUCTION, USE, PATENT RIGHTS AND SALES RIGHTS ARE EXPRESSLY RESERVED BY SAMTEC, INC. THIS DOCUMENT SHALL NOT BE DISCLOSED, IN WHOLE OR PART, TO ANY UNAUTHORIZED PERSON OR ENTITY NOR REPRODUCED, TRANSFERRED OR INCORPORATED IN ANY OTHER PROJECT IN ANY MANNER WITHOUT THE EXPRESS WRITTEN CONSENT OF SAMTEC, INC. *



520 PARK EAST BLVD., NEW ALBANY, IN 47150
 PHONE: 812-944-6733 FAX: 812-948-5047
 e-Mail: info@SAMTEC.com code: 55322

DO NOT SCALE DRAWING

DESCRIPTION:
 TRUE 75 OHM, DIN 1.0/2.3 STRAIGHT PLUG, RG179

DWG. NO.
DIN7A-PP-C-XX-ST-CA3-X

SHEET SCALE: 1:0.666667

BY: TALON Z 02/22/2010 SHEET 3 OF 3