



High-Frequency Switchmode Controller

FEATURES

- 15- to 200-V Input Range
- Current-Mode Control
- Internal Start-Up Circuit
- Latched SHUTDOWN
- Soft-Start
- 1.8-MHz Error Amp

DESCRIPTION

The Si9114A is a BiC/DMOS current-mode pulse width modulation (PWM) controller IC for high-frequency dc/dc converters. Single-ended topologies (forward and flyback) can be implemented at frequencies up to 1 MHz. The oscillator has an internal divide-by-two that limits the duty ratio to 50%. An oscillator sync output allows converters to be synchronized in phase as well as in frequency, in a master/slave configuration.

The high-voltage DMOS transistor allows the IC to interface directly to bus voltages up to 200 V. Other features include a 1.5% accurate voltage reference, 1.8-MHz (min) bandwidth error amplifier, shutdown logic control, soft-start and undervoltage lockout circuits.

The output inverter can typically source 500 mA and sink 700 mA. Shoot-through current is all but eliminated to minimize supply current requirements.

The Si9114A is available in both standard and lead (Pb)-free 14-pin plastic DIP and SOIC packages, and is specified over the industrial, D suffix (-40°C to 85°C) temperature range.

FUNCTIONAL BLOCK DIAGRAM

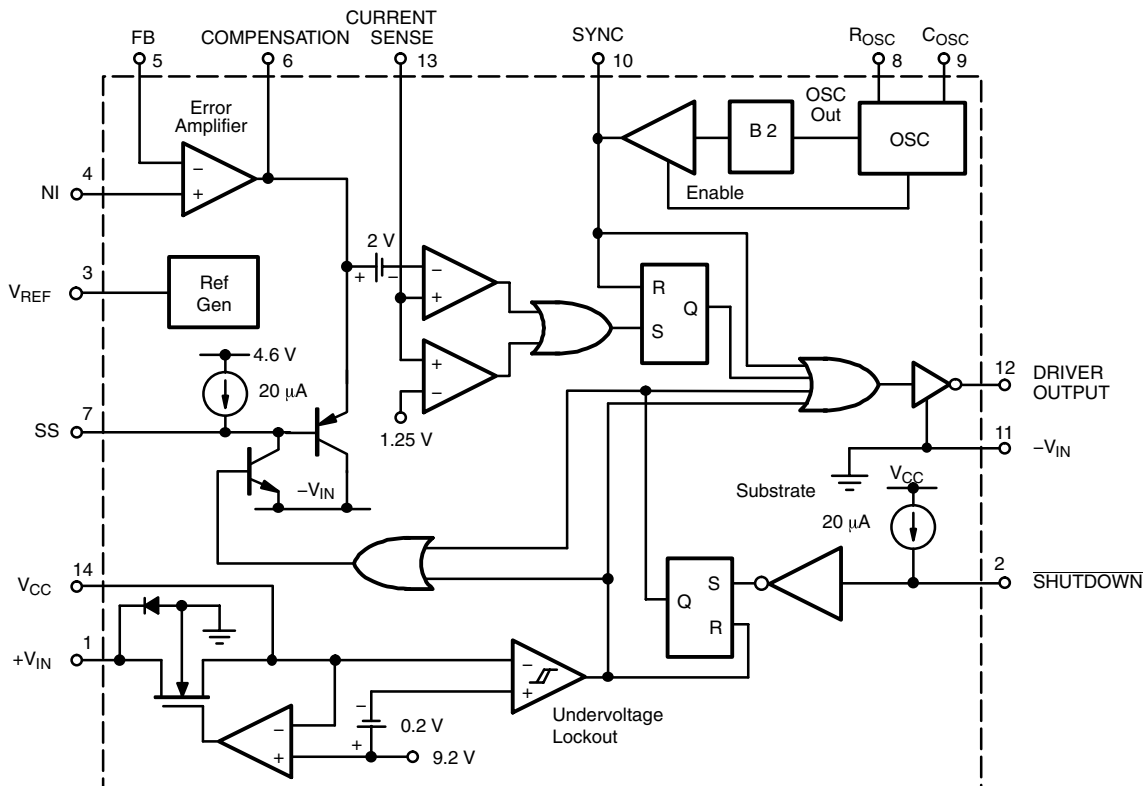



ABSOLUTE MAXIMUM RATINGS

Voltages Referenced to $-V_{IN}$	
V_{CC}	18 V
$+V_{IN}$ (Note: $V_{CC} < +V_{IN} + 0.3$ V)	200 V
Logic Input (SHUTDOWN, SYNC)	-0.3 V to $V_{CC} + 0.3$ V
Linear Inputs (FEEDBACK, SENSE, SOFT-START)	-0.3 V to $V_{CC} + 0.3$ V
HV Pre-Regulator Input Current (continuous)	5 mA
Storage Temperature	-65 to 150°C
Operating Temperature	-40 to 85°C
Junction Temperature (T_J)	150°C

Power Dissipation (Package) ^a	
14-Pin Plastic Dip (J Suffix) ^b	750 mW
14-Pin SOIC (Y Suffix) ^c	900 mW
Thermal Impedance (Θ_{JA})	
14-Pin Plastic Dip	167°C/W
14-Pin SOIC	140°C/W

Notes

- Device mounted with all leads soldered or welded to PC board.
- Derate 6 mW/°C above 25°C.
- Derate 7.2 mW/°C above 25°C.

Stresses beyond those listed under "Absolute Maximum Ratings" may cause permanent damage to the device. These are stress ratings only, and functional operation of the device at these or any other conditions beyond those indicated in the operational sections of the specifications is not implied. Exposure to absolute maximum rating conditions for extended periods may affect device reliability.

RECOMMENDED OPERATING RANGE

Voltages Referenced to $-V_{IN}$	
V_{CC}	9.5 V to 16.5 V
$+V_{IN}$	15 V to 200 V
f_{OSC}	20 kHz to 2 MHz

R_{OSC}	56 kΩ to 1 MΩ
C_{OSC}	47 pF to 200 pF
Linear Inputs	0 to $V_{CC} - 4$ V
Digital Inputs	0 to V_{CC}

SPECIFICATIONS						
Parameter	Symbol	Test Conditions Unless Otherwise Specified Oscillator Disabled $-V_{IN} = 0$ V, $V_{CC} = 10$ V	Limits D Suffix -40 to 85°C			Unit
			Min ^a	Typ ^b	Max ^a	
Reference						
Output Voltage	V_R	OSC Disabled, $T_A = 25^\circ\text{C}$	3.94	4.0	4.06	V
		OSC Disabled Over Voltage and Temperature Ranges ^c	3.88	4.0	4.12	
Short Circuit Current	I_{SREF}	$V_{REF} = -V_{IN}$		-30	-5	mA
Load Regulation	$\Delta V_R / \Delta I_R$	$I_{REF} = 0$ to -1 mA		10	40	mV
Oscillator						
Initial Accuracy	f_{OSC}^d	$R_{OSC} = 374$ kΩ, $C_{OSC} = 200$ pF	90	100	110	kHz
		$R_{OSC} = 70$ kΩ, $C_{OSC} = 200$ pF	450	500	550	
Voltage Stability ^c	$\Delta f/f$	$R_{OSC} = 70$ kΩ, $C_{OSC} = 200$ pF $\Delta f/f = [f(16.5 \text{ V}) - f(9.5 \text{ V})] / f(9.5 \text{ V})$		4	7	%
Temperature Coefficient ^c	OSC TC	$-40 \leq T_A \leq 85^\circ\text{C}$, $f_{OSC} = 100$ kHz		200	500	ppm/°C
Sync Output Current (Master Mode)	$I_{SYNC(M)}$	$V_{ROSC} \leq 5$ V	± 1.0	± 3.0		mA
Sync Output Current (Slave Mode)	$I_{SYNC(S)}$	$V_{ROSC} = V_{CC}$		± 1	± 500	nA
Error Amplifier ($C_{OSC} = -V_{IN}$ OSC Disabled)						
Input BIAS Current	I_{FB}	$V_{FB} = 5$ V, $I_I = V_{REF}$		<1.0	± 200	nA
Input OFFSET Voltage	V_{OS2}			± 5	± 25	mV
Open Loop Voltage Gain ^c	A_{VOL}		65	80		dB
Unity Gain Bandwidth ^c	BW		1.8	2.7		MHz
Output Current	I_{OUT}	Source ($V_{FB} = 3.5$ V, $I_I = V_{REF}$)		-2.7	-1.0	mA
		Sink ($V_{FB} = 4.5$ V, $I_I = V_{REF}$)	1.0	2.4		
Power Supply Rejection	PSRR	$9.5 \text{ V} \leq V_{CC} \leq 16.5 \text{ V}$	50	80		dB



SPECIFICATIONS							
Parameter	Symbol	Test Conditions Unless Otherwise Specified Oscillator Disabled -V _{IN} = 0 V, V _{CC} = 10 V	Limits D Suffix -40 to 85°C			Unit	
			Min ^a	Typ ^b	Max ^a		
Pre-Regulator/Start-Up							
Input Leakage Current	+I _{IN}	+V _{IN} = 200 V, V _{CC} ≥ 10 V		< 1	10	μA	
Pre-Regulator Start-Up Current	I _{START}	+V _{IN} = 48 V, t _{PW} ≤ 300 μs, V _{CC} = V _{UVLO}	8	20		mA	
V _{CC} Pre-Regulator Voltage	V _{PR}	+V _{IN} = 48 V	8.8	9.1	9.4	V	
V _{PR} -V _{UVLO} (Turn-On)	V _{DELTA}		0.1	0.25	0.7		
Undervoltage Lockout Hysteresis	V _{HYST}		0.18	0.28	0.4		
Supply							
Supply Current	I _{CC}	C _{LOAD} ≤ 50 pF	f _{OSC} = 100 kHz		1.5	2.5	mA
			f _{OSC} = 500 kHz		2.2	3.0	
Protection							
Current Limit Threshold Voltage	V _{SENSE}	V _{FB} = 0 V, NI = V _{REF}	1.15	1.23	1.30	V	
Current Limit Delay to Output ^c	t _d	V _{SENSE} = 1.5 V, See Figure 1		77	100	ns	
SHUTDOWN Logic Threshold	V _{SD}			2.8	0.5	V	
SHUTDOWN Delay to Latched Output ^c	t _{SD}	See Figure 2		0.20	1.0	μs	
SHUTDOWN Pull-Up Current	I _{SD}	V _{SD} = 0 V	12	23	30	μA	
Soft-Start Current	I _{SS}		12	23	30		
Output Inhibit Voltage	V _{SS(off)}	Soft-Start Voltage to Disable Driver Output		1.6	0.5	V	
MOSFET Driver							
Output High Voltage	V _{OH}	I _{OUT} = -10 mA	9.85	9.9		V	
Output Low Voltage	V _{OL}	I _{OUT} = 10 mA		0.05	0.15		
Peak Output Current ^c	I _{SOURCE}	V _{OUT} = 0 V		-400	-200	mA	
	I _{SINK}	V _{OUT} = V _{CC}	500	1000			

Notes

- a. The algebraic convention whereby the most negative value is a minimum and the most positive a maximum.
- b. Typical values are for DESIGN AID ONLY, not guaranteed nor subject to production testing.
- c. Guaranteed by design, not subject to production test.
- d. C_{STRAY} ≤ 5 pF on C_{OSC}.



TYPICAL CHARACTERISTICS

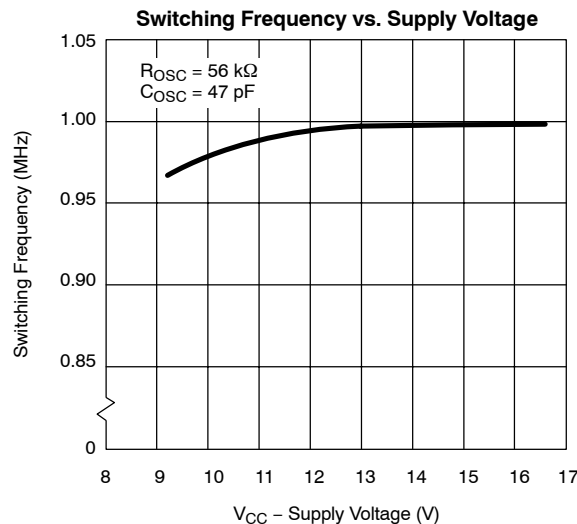
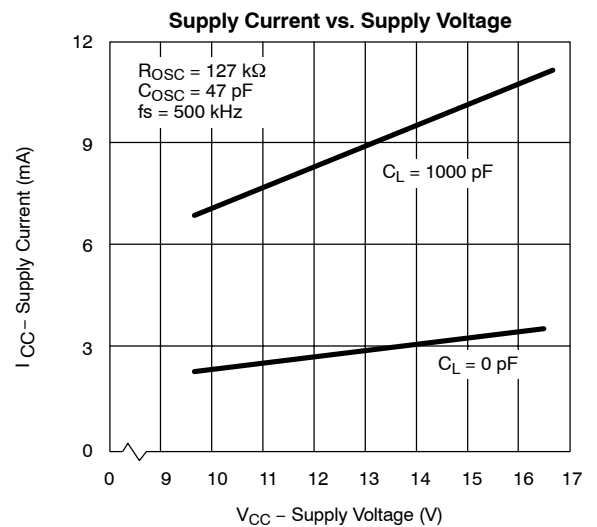
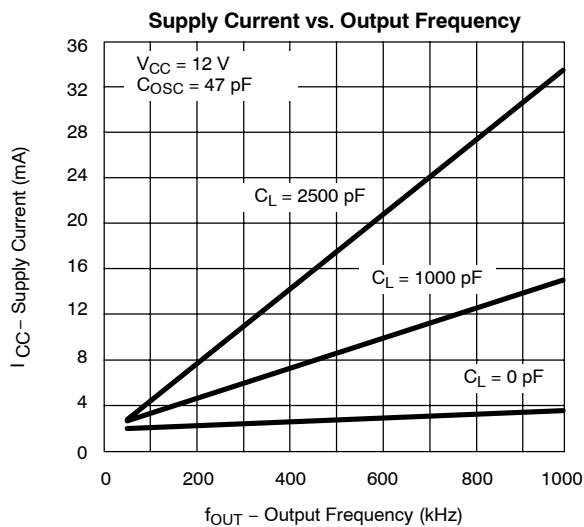
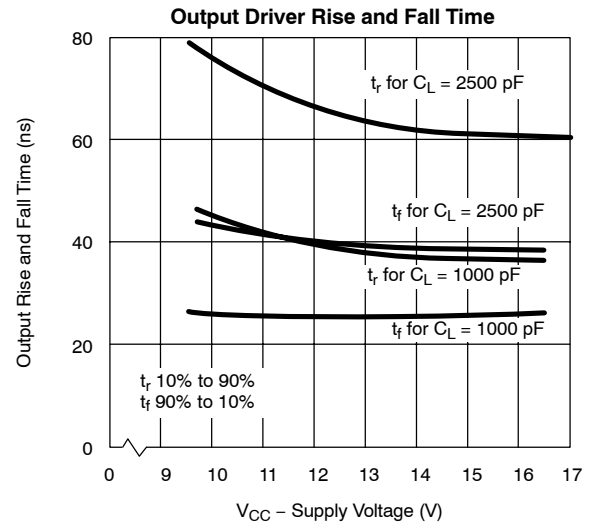
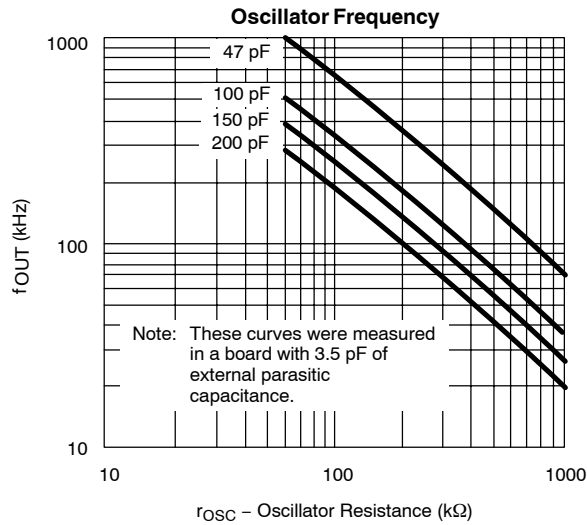

TIMING WAVEFORMS

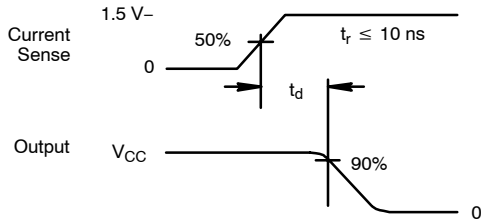

FIGURE 1.

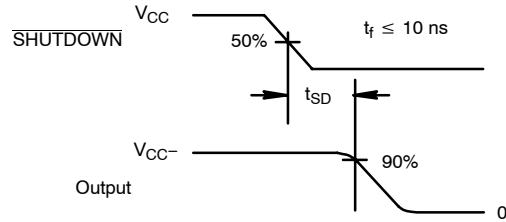
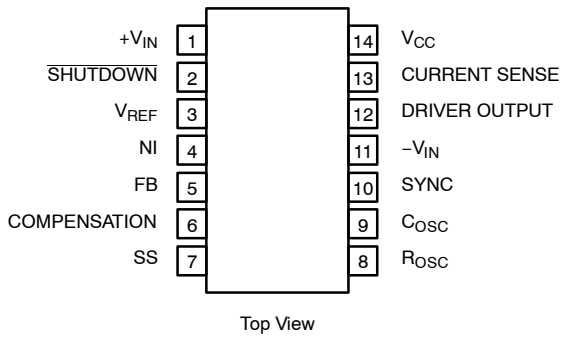

FIGURE 2.

PIN CONFIGURATIONS AND ORDERING INFORMATION

Dual-In-Line and SOIC



ORDERING INFORMATION

Part Number	Temperature Range	Package
Si9114ADY	-40 to 85°C	SOIC-14
Si9114ADY-T1		
Si9114ADY-T1—E3		
Si9114ADJ		PDIP-14
Si9114ADJ—E3		

APPLICATIONS

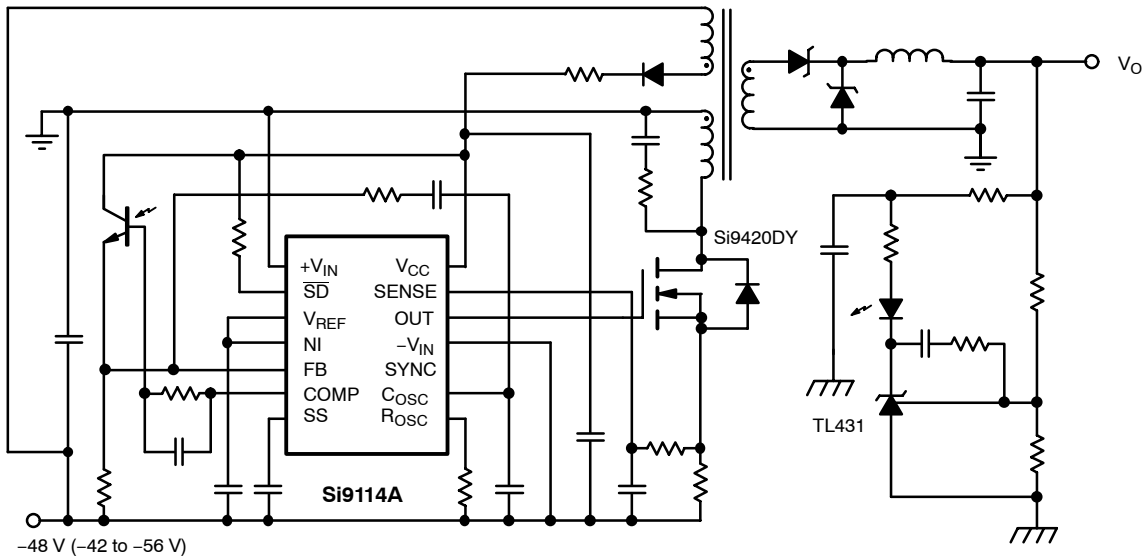
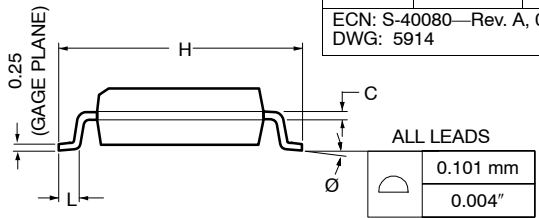
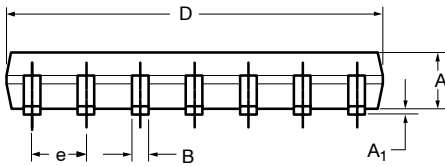
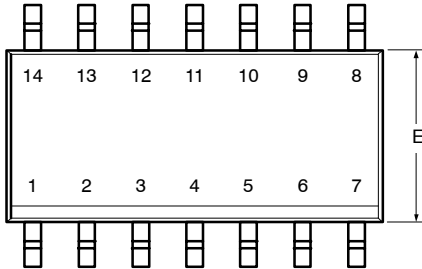

FIGURE 3. 15-W Forward Converter Schematic

Vishay Siliconix maintains worldwide manufacturing capability. Products may be manufactured at one of several qualified locations. Reliability data for Silicon Technology and Package Reliability represent a composite of all qualified locations. For related documents such as package/tape drawings, part marking, and reliability data, see <http://www.vishay.com/ppg?70025>.



SOIC (NARROW): 14-LEAD (POWER IC ONLY)



Dim	MILLIMETERS		INCHES	
	Min	Max	Min	Max
A	1.35	1.75	0.053	0.069
A₁	0.10	0.20	0.004	0.008
B	0.38	0.51	0.015	0.020
C	0.18	0.23	0.007	0.009
D	8.55	8.75	0.336	0.344
E	3.8	4.00	0.149	0.157
e	1.27 BSC		0.050 BSC	
H	5.80	6.20	0.228	0.244
L	0.50	0.93	0.020	0.037
Ø	0°	8°	0°	8°

ECN: S-40080—Rev. A, 02-Feb-04
DWG: 5914



PDIP: 14-LEAD (POWER IC ONLY)

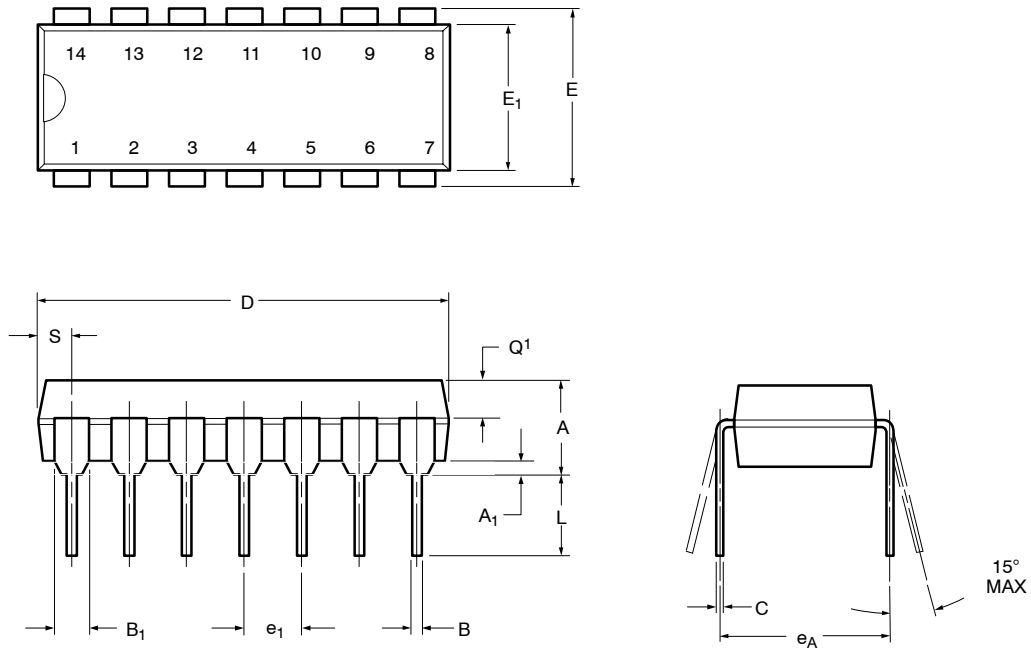

Dim	MILLIMETERS		INCHES	
	Min	Max	Min	Max
A	3.81	5.08	0.150	0.200
A₁	0.38	1.27	0.015	0.050
B	0.38	0.51	0.015	0.020
B₁	0.89	1.65	0.035	0.065
C	0.20	0.30	0.008	0.012
D	17.27	19.30	0.680	0.760
E	7.62	8.26	0.300	0.325
E₁	5.59	7.11	0.220	0.280
e₁	2.29	2.79	0.090	0.110
e_A	7.37	7.87	0.290	0.310
L	2.79	3.81	0.110	0.150
Q₁	1.27	2.03	0.050	0.080
S	1.02	2.03	0.040	0.080

ECN: S-40081—Rev. A, 02-Feb-04
DWG: 5919



Disclaimer

ALL PRODUCT, PRODUCT SPECIFICATIONS AND DATA ARE SUBJECT TO CHANGE WITHOUT NOTICE TO IMPROVE RELIABILITY, FUNCTION OR DESIGN OR OTHERWISE.

Vishay Intertechnology, Inc., its affiliates, agents, and employees, and all persons acting on its or their behalf (collectively, "Vishay"), disclaim any and all liability for any errors, inaccuracies or incompleteness contained in any datasheet or in any other disclosure relating to any product.

Vishay makes no warranty, representation or guarantee regarding the suitability of the products for any particular purpose or the continuing production of any product. To the maximum extent permitted by applicable law, Vishay disclaims (i) any and all liability arising out of the application or use of any product, (ii) any and all liability, including without limitation special, consequential or incidental damages, and (iii) any and all implied warranties, including warranties of fitness for particular purpose, non-infringement and merchantability.

Statements regarding the suitability of products for certain types of applications are based on Vishay's knowledge of typical requirements that are often placed on Vishay products in generic applications. Such statements are not binding statements about the suitability of products for a particular application. It is the customer's responsibility to validate that a particular product with the properties described in the product specification is suitable for use in a particular application. Parameters provided in datasheets and / or specifications may vary in different applications and performance may vary over time. All operating parameters, including typical parameters, must be validated for each customer application by the customer's technical experts. Product specifications do not expand or otherwise modify Vishay's terms and conditions of purchase, including but not limited to the warranty expressed therein.

Hyperlinks included in this datasheet may direct users to third-party websites. These links are provided as a convenience and for informational purposes only. Inclusion of these hyperlinks does not constitute an endorsement or an approval by Vishay of any of the products, services or opinions of the corporation, organization or individual associated with the third-party website. Vishay disclaims any and all liability and bears no responsibility for the accuracy, legality or content of the third-party website or for that of subsequent links.

Except as expressly indicated in writing, Vishay products are not designed for use in medical, life-saving, or life-sustaining applications or for any other application in which the failure of the Vishay product could result in personal injury or death. Customers using or selling Vishay products not expressly indicated for use in such applications do so at their own risk. Please contact authorized Vishay personnel to obtain written terms and conditions regarding products designed for such applications.

No license, express or implied, by estoppel or otherwise, to any intellectual property rights is granted by this document or by any conduct of Vishay. Product names and markings noted herein may be trademarks of their respective owners.