

### ■ Dimensions

**Note:** All units are in millimeters unless otherwise indicated.

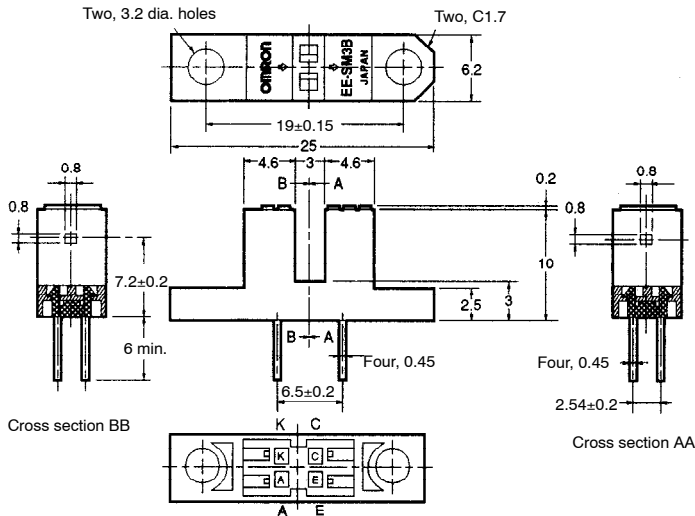

### Internal Circuit

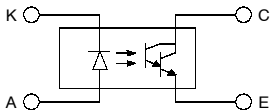

Unless otherwise specified, the tolerances are as shown below.

Dimensions	Tolerance
3 mm max.	±0.3
3 < mm ≤ 6	±0.375
6 < mm ≤ 10	±0.45
10 < mm ≤ 18	±0.55
18 < mm ≤ 30	±0.65

Terminal No.	Name
A	Anode
K	Cathode
C	Collector
E	Emitter

### ■ Features

- General-purpose model with a 3-mm-wide slot.
- PCB mounting type.
- With a red LED as an emitter element and a Photo-Darlington transistor as a detector element.

### ■ Absolute Maximum Ratings (Ta = 25°C)

Item	Symbol	Rated value
Emitter	Forward current	I <sub>F</sub> 15 mA (see note 1)
	Pulse forward current	I <sub>FP</sub> ---
	Reverse voltage	V <sub>R</sub> 4 V
Detector	Collector-Emitter voltage	V <sub>CEO</sub> 24 V
	Emitter-Collector voltage	V <sub>ECO</sub> ---
	Collector current	I <sub>C</sub> 20 mA
	Collector dissipation	P <sub>C</sub> 75 mW (see note 1)
	Ambient temperature	Operating
	Storage	T <sub>stg</sub> -20°C to 80°C
Soldering temperature		T <sub>sol</sub> 260°C (see note 2)

- Note:**
1. Refer to the temperature rating chart if the ambient temperature exceeds 25°C.
  2. Complete soldering within 10 seconds.

### ■ Ordering Information

Description	Part number
Photomicrosensor (Transmissive)	EE-SM3B

### ■ Electrical and Optical Characteristics (Ta = 25°C)

Item	Symbol	Value	Condition
Emitter	Forward voltage	V <sub>F</sub> 2.0 V typ., 2.6 V max.	I <sub>F</sub> = 15 mA
	Reverse current	I <sub>R</sub> 0.01 μA typ., 5 μA max.	V <sub>R</sub> = 4 V
	Peak emission wavelength	λ <sub>P</sub> 700 nm typ.	I <sub>F</sub> = 3 mA
Detector	Light current	I <sub>L</sub> 1.5 mA min., 120 mA max.	I <sub>F</sub> = 3 mA, V <sub>CE</sub> = 10 V
	Dark current	I <sub>D</sub> 2 nA typ., 250 nA max.	V <sub>CE</sub> = 10 V, 0 lx
	Leakage current	I <sub>LEAK</sub> ---	---
	Collector-Emitter saturated voltage	V <sub>CE (sat)</sub> 0.9 V typ.	I <sub>F</sub> = 3 mA, I <sub>L</sub> = 0.5 mA
	Peak spectral sensitivity wavelength	λ <sub>P</sub> 800 nm typ.	V <sub>CE</sub> = 10 V
Rising time	t <sub>r</sub> 180 μs typ.	V <sub>CC</sub> = 5 V, R <sub>L</sub> = 100 Ω, I <sub>L</sub> = 10 mA	
Falling time	t <sub>f</sub> 60 μs typ.	V <sub>CC</sub> = 5 V, R <sub>L</sub> = 100 Ω, I <sub>L</sub> = 10 mA	

■ Engineering Data

**Forward Current vs. Collector Dissipation Temperature Rating**

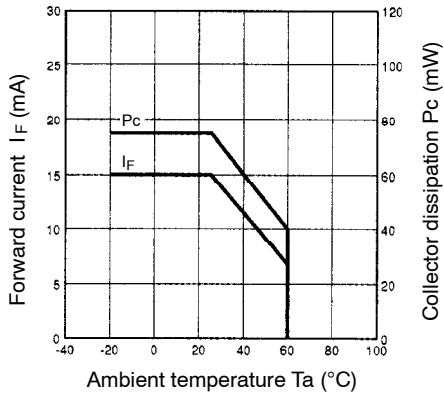

**Forward Current vs. Forward Voltage Characteristics (Typical)**

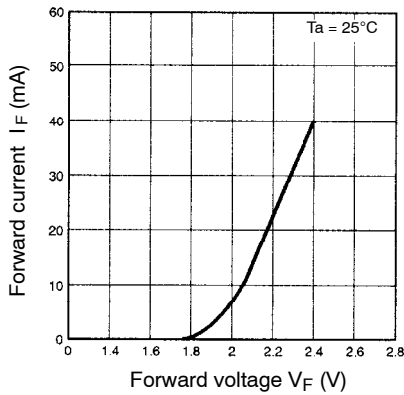

**Light Current vs. Forward Current Characteristics (Typical)**

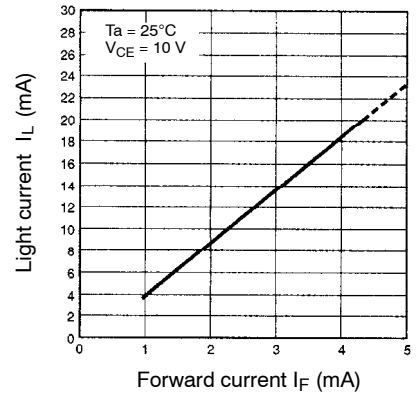

**Light Current vs. Collector-Emitter Voltage Characteristics (Typical)**

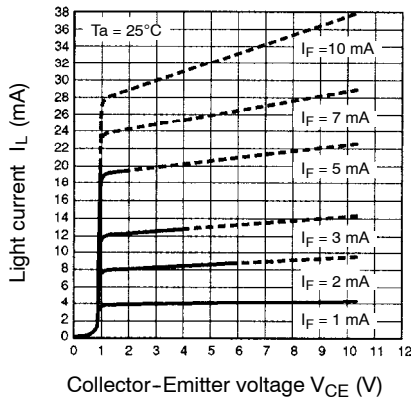

**Relative Light Current vs. Ambient Temperature Characteristics (Typical)**

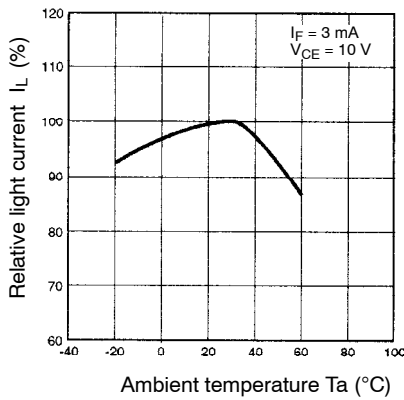

**Dark Current vs. Ambient Temperature Characteristics (Typical)**

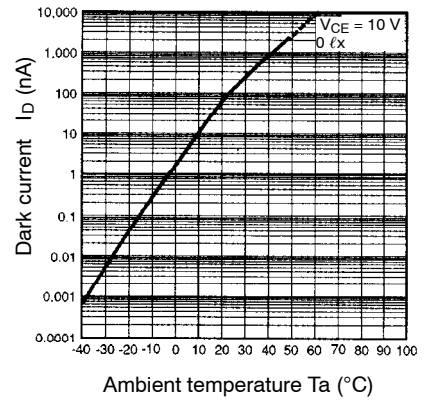

**Response Time vs. Load Resistance Characteristics (Typical)**

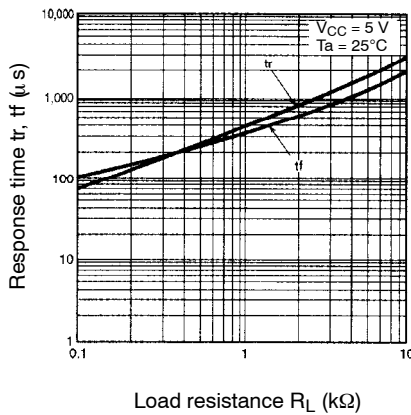

**Sensing Position Characteristics (Typical)**

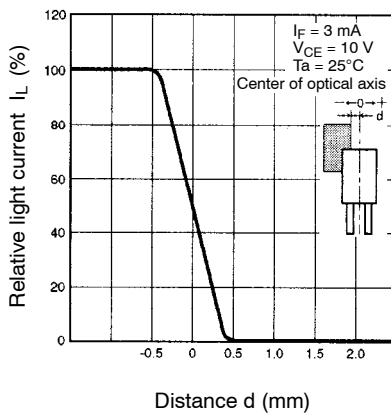

**Response Time Measurement Circuit**

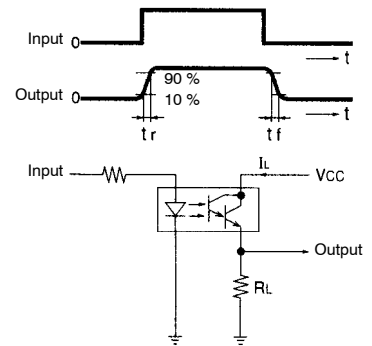

**NOTE: DIMENSIONS SHOWN ARE IN MILLIMETERS. To convert millimeters to inches divide by 25.4.**

---

**OMRON**<sup>®</sup>

**OMRON ELECTRONICS LLC**

One East Commerce Drive  
Schaumburg, IL 60173

**847-882-2288**

**OMRON CANADA, INC.**

885 Milner Avenue  
Toronto, Ontario M1B 5V8

**416-286-6465**

**OMRON ON-LINE**

Global – <http://www.omron.com>  
USA – <http://www.omron.com/oei>  
Canada – <http://www.omron.com/oci>