

ISS.	AMEND	DATE
1	ISSUED	12/02/15
2	ADD WHITE VARIANTS	03/02/20

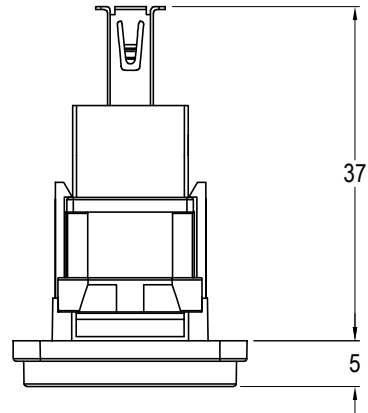

PANEL CUTOUT
MAXIMUM PANEL
THICKNESS 3mm

HOLES TO SUIT
SCREW USED

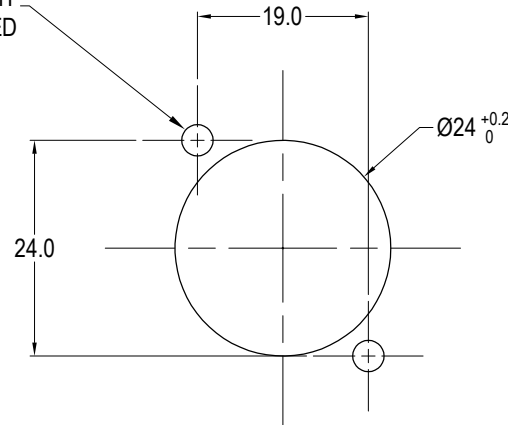

Material:

1. Insert: ABS UL94 HB
2. Frame: Polyamide UL94 V-2
3. Inner Overmouldings: PE + PVC
4. Shell: Nickel plated steel
5. Contacts: Gold Plated

PART NO.	COLOUR	FIXING HOLE DETAILS
CP30205N	BLACK	HOLE $\varnothing 3.50$ X CSK 82° X $\varnothing 5.85$
CP30205NW	WHITE	
CP30205NX	BLACK	PLAIN HOLE $\varnothing 2.50$
CP30205NXW	WHITE	

Notes:

1. Voltage rating: 30V ac
2. Current rating: 1.8 A max
3. Contact resistance: 50m Ω max
4. Insulation resistance: 20M Ω min
5. Dielectric withstanding voltage: 500V AC
6. Operating Temperature: -20°C to 50°C

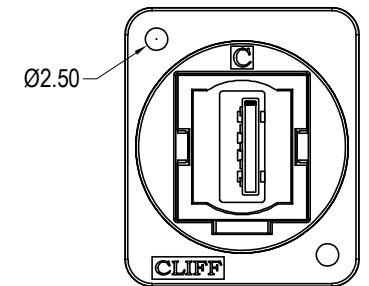

'X' VERSION
 $\varnothing 2.5$ PLAIN HOLES

RoHS
COMPLIANT

TOLERANCE
NO DEC. PLACE \pm
1 DEC. PLACE \pm
2 DEC. PLACE \pm
HOLE \varnothing \pm
ANGLES \pm
UNLESS
OTHERWISE STATED

DO NOT SCALE

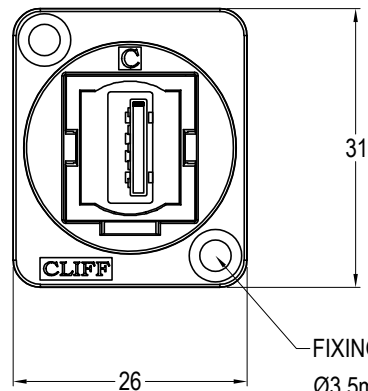
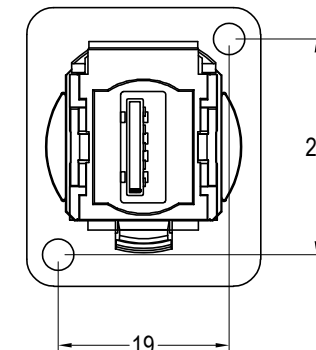
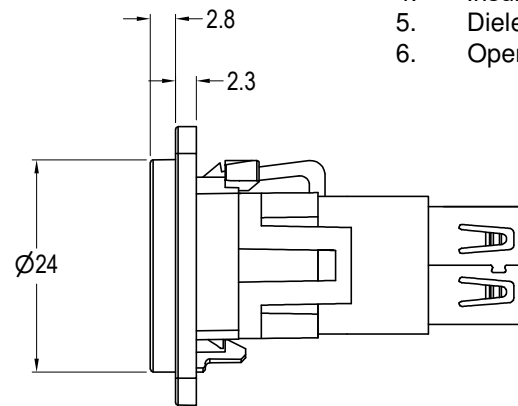

FIXING HOLE VARIANTS:
 $\varnothing 3.5$ mm CSK 82° x $\varnothing 5.85$
'X' VERSION HAS $\varnothing 2.5$ PLAIN HOLES.

Cliff Electronic Components Ltd.

76 Holmethorpe Avenue, Holmethorpe Industrial Estate,
Redhill, Surrey, RH1 2PF, England, UK
Tel: 01737-771375 Fax: 01737-766012 Website: www.cliffuk.co.uk

THE CONTENTS OF THIS DOCUMENT MUST NOT BE COPIED OR DISCLOSED TO A 3rd PARTY WITHOUT WRITTEN PERMISSION OF CLIFF UK. © 2015

DIMENSIONS IN MILLIMETERS UNLESS OTHERWISE STATED. WORK TO DIMENSIONS. REMOVE ALL BURRS. IF IN DOUBT ASK.

3rd ANGLE PROJECTION:

MATERIAL: See Notes

FINISH: See Notes

DRAWN: D.P.J.

APPROVED: D.P.J.

TITLE: FEED THROUGH USB 3.0 A to USB 3.0 A, Nickel Plated

DRWG. No. **CP30205N** FORM: A4DRWGH