

## Solder Instruction b

1. Cable should be prepared for soldering. The cable/wires must be pretinned.
2. Insert cable/wire into solder cup.
3. Operate the soldering iron at 350 °C, 50 Watt max. and use a pencil tip.
4. Put tip to wire in solder cup.
5. After 1 second bring in solder.
6. Heat for 3 seconds longer. Do not heat contact more than 4 seconds in total.
7. Remove soldering iron.
8. Wait until solder gets rigid again.
9. Do not solder adjacent contacts consecutively, alternate position within the connector to minimize heat build up.

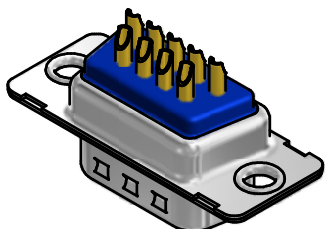
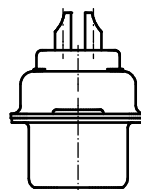
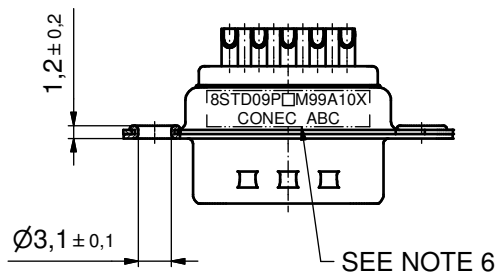
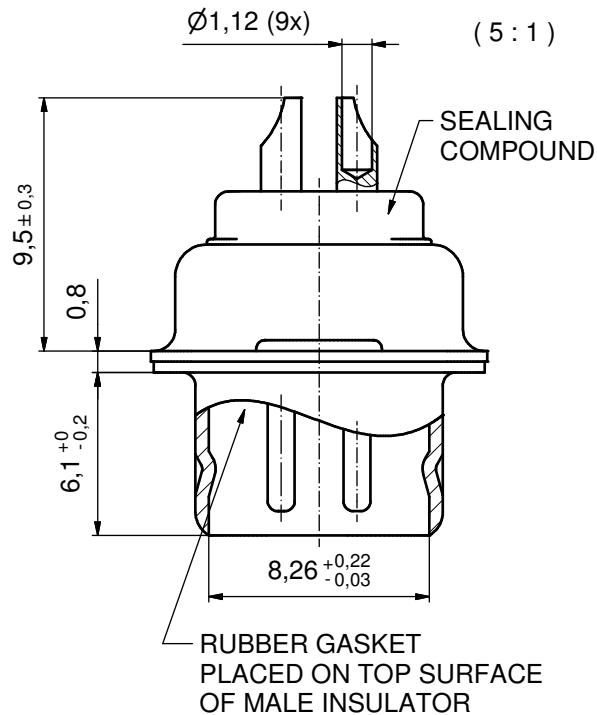
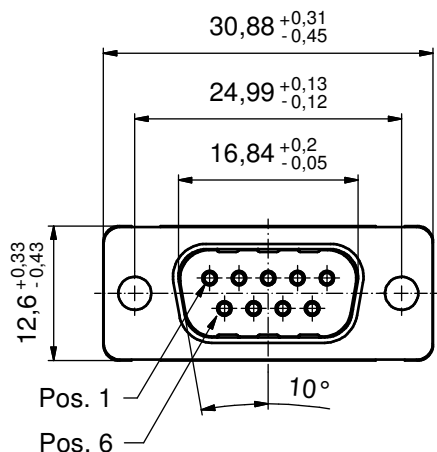

### b NOTES:

1. METALSHHELLS: STAINLESS STEEL
2. INSULATORS: PBT GF UL 94 V-0; BLACK
3. SIGNAL CONTACTS: COPPER ALLOY; PLATING (SEE PART NO.)
  - PLEASE ADD J for 50µm HARD GOLD over min. 50µm NICKEL
  - PLEASE ADD C for 30µm HARD GOLD over min. 50µm NICKEL
  - PLEASE ADD B for 20µm HARD GOLD over min. 50µm NICKEL
  - PLEASE ADD A for GOLD FLASH over NICKEL (PREFERRED TYPE)
- SOLDER CUP ACCEPTS CABLE AWG 20
4. SEALING COMPOUND: PUR; BLUE
5. RUBBER-GASKET: TPE; BLACK
6. CONNECTOR IS PART MARKED: 8STD09P□M99A10X CONEC ABC (see note 3)

Directive 2002/95/EC RoHS compliant

THIS DRAWING MAY NOT BE COPIED OR REPRODUCED IN ANY WAY, AND MAY NOT BE PASSED ON TO A THIRD PARTY WITHOUT WRITTEN PERMISSION. OWNERSHIP AND COPYRIGHT OF CONEC GmbH DO NOT ALTER CAD DRAWING BY HAND					tolerance	dim. in mm	scale: 2:1 (5:1)		
					date		name	material: SEE NOTES	
					drawn	02.06.10	Lehmenkühler		
					appd.	02.06.10	Fischer		
					norm				
					d-old	18K1A655/18K2A655			
3 x b	Ä4438	23.08.2012	K.H.				title: <b>D-SUB MALE</b> 9pos. SOLDER CUP for installation into water resistant hood		
a	Original						dwg no:	15K1A650	DIN-A3 sh: 1
rev.	description	date	name				part no:	8STD09P□M99A10X (see note 3)	