

THIS DRAWING IS UNPUBLISHED. RELEASED FOR PUBLICATION 20
 © COPYRIGHT 20 BY - ALL RIGHTS RESERVED.

REVISIONS				
P	LTR	DESCRIPTION	DATE	APVD
1		PRELIMINARY	24OCT2013	JY

2-2170724-2 AS SHOWN

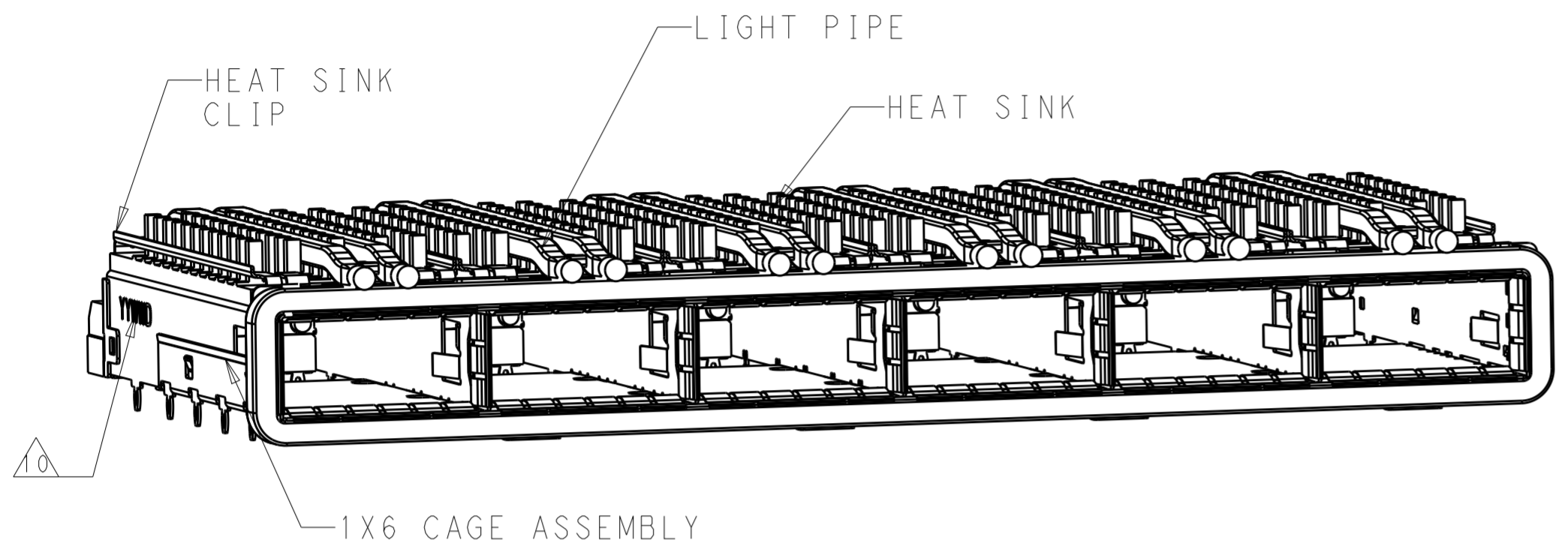

- COMPONENTS
 CAGE ASSEMBLY: NICKEL-SILVER ALLOY
 HEAT SINK: ALUMINUM/BLACK ANODIZE
 HEAT SINK CLIP: STAINLESS STEEL
 EMI SPRING: COPPER ALLOY/NICKEL PLATE
 LIGHT PIPE: CLEAR POLYCARBONATE WITH 94 V-0
 EMI GASKET: PLATED FILLED SILICONE WITH 94 V-0
- REFERENCE APPLICATION SPECIFICATION 114-***** FOR RECOMMENDED DRILL HOLE DIAMETER AND PLATING THICKNESS
- DATUM AND BASIC DIMENSION ESTABLISHED BY CUSTOMER
- DIMENSION APPLIES WITH MODULE INSERTED IN CAGE
- HEAT SINKS, HEAT SINK CLIPS AND LIGHT PIPES ARE SHIPPED ASSEMBLED ON CAGE
- MINIMUM PC BOARD THICKNESS: SINGLE SIDED: 1.57 MIN
 DOUBLE SIDED: 3.00 MIN
- DATUM **-A-** IS TOP SURFACE OF THE HOST BOARD.
- THESE HOLES ARE OPTIONAL WHEN THE REAR PINS ARE REMOVED.
- MATES WITH QSFP28 MSA COMPATIBLE TRANSCEIVER.
- DATE CODE (YYWWD) MARKED APPROXIMATELY AS SHOWN.
- NOTED DIMENSIONS ONLY APPLY TO CAGE ASSEMBLY WITH LIGHT PIPE.

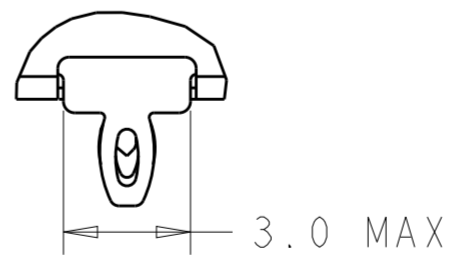
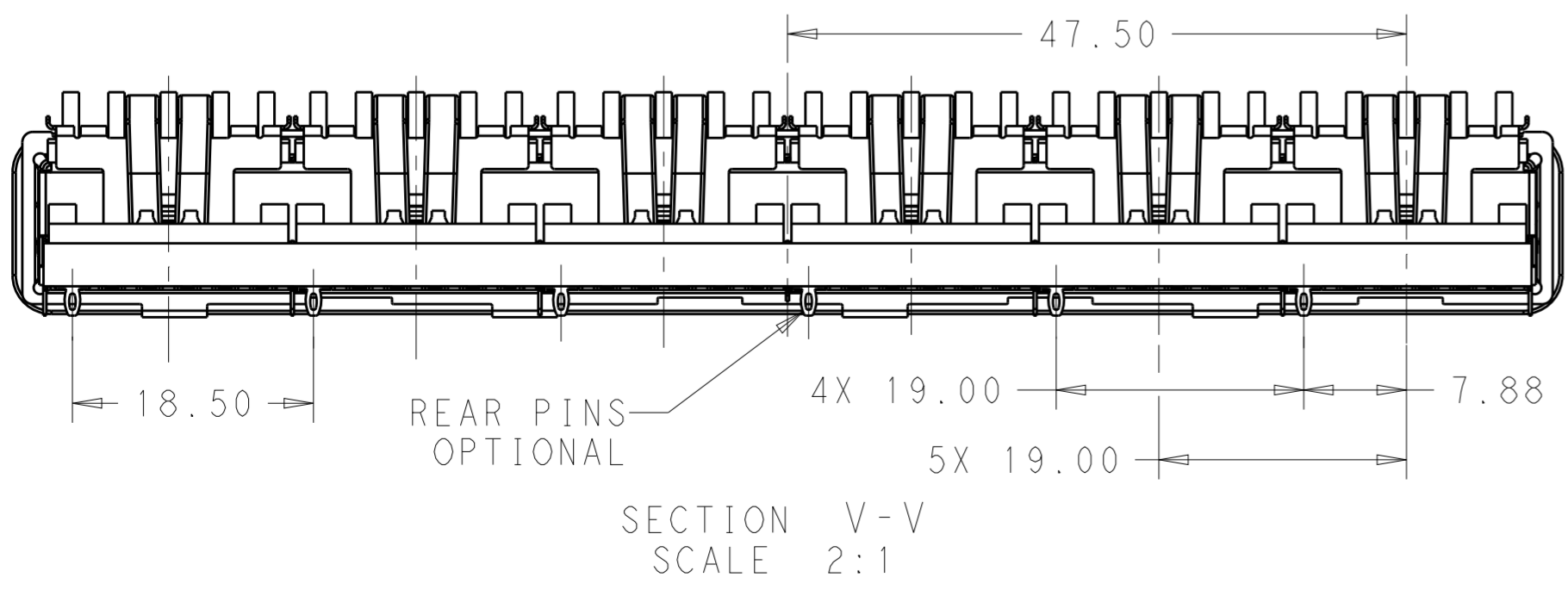
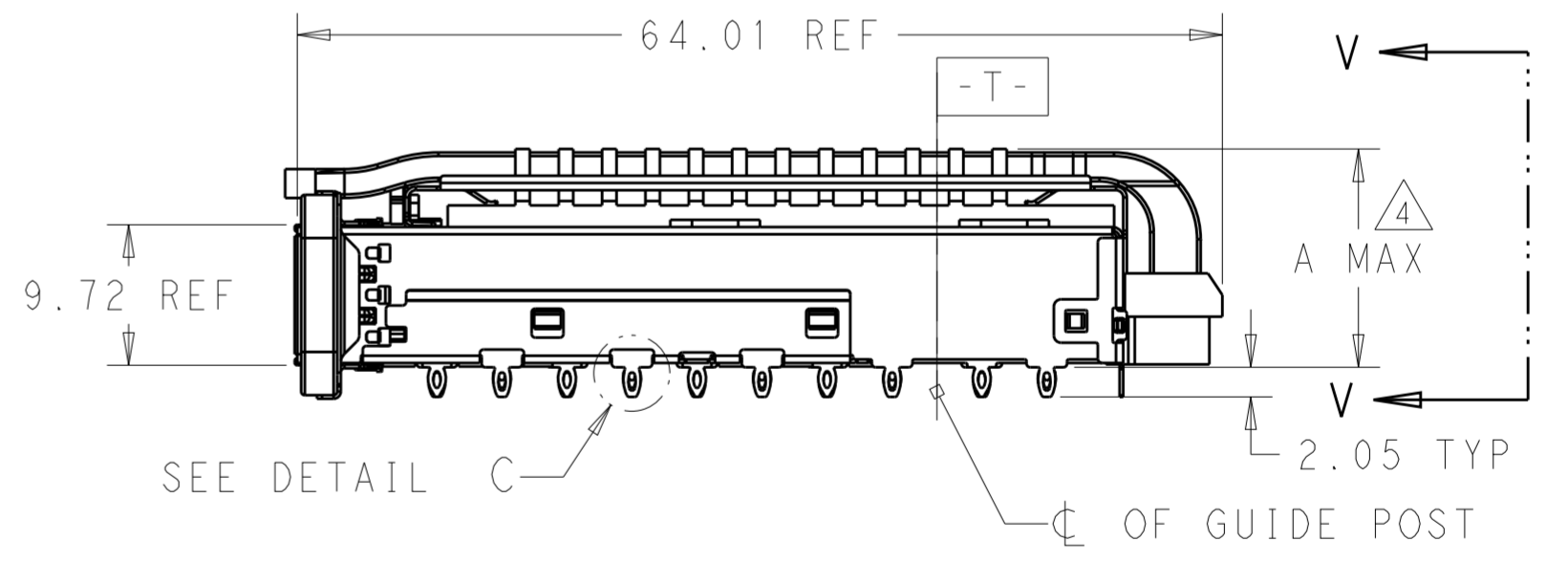
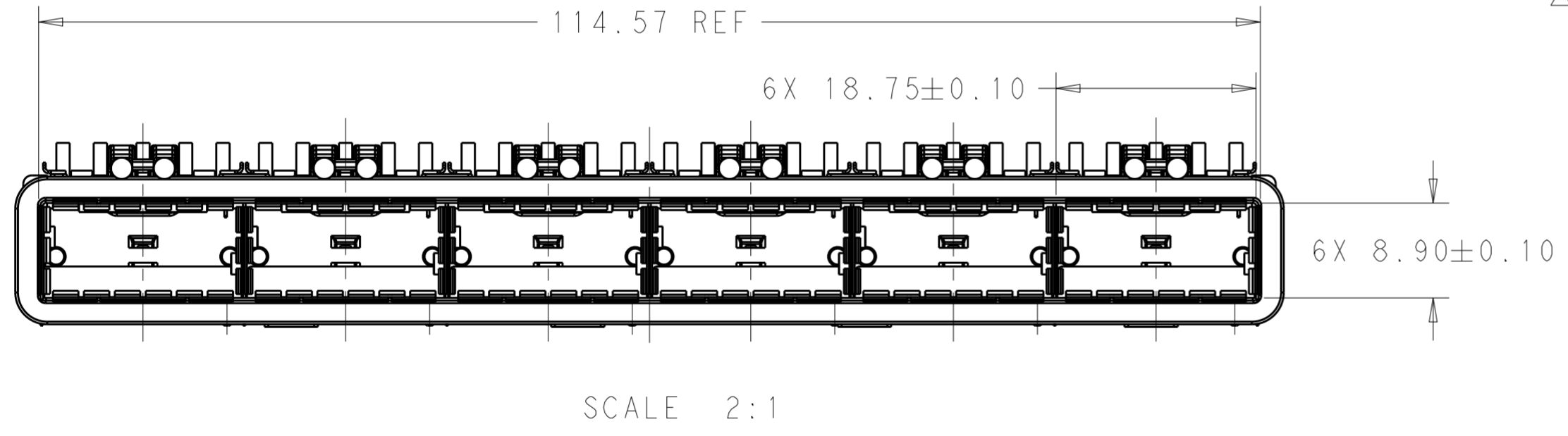

DETAIL C
 SCALE 6:1

PRELIMINARY PART- NOT RELEASED FOR PRODUCTION

THIS DRAWING IS A CONTROLLED DOCUMENT.		DWN JASON YANG	24OCT2013	TE Connectivity	
DIMENSIONS: mm		CHK	APVD		
TOLERANCES UNLESS OTHERWISE SPECIFIED:		PRODUCT SPEC	APPLICATION SPEC	SIZE A200779	CAGE CODE C-2170724
0 PLC ±		WEIGHT	Customer Drawing	SCALE 3:1	SHEET 1 OF 9
1 PLC ±0.25				REV 1	
2 PLC ±0.2					
3 PLC ±					
4 PLC ±					
ANGLES ±					
FINISH					
MATERIAL SEE NOTES					
SEE NOTES					

REVISIONS				
P	LTR	DESCRIPTION	DATE	APVD
-		SEE SHEET 1	-	-

HEAT SINK OPTION

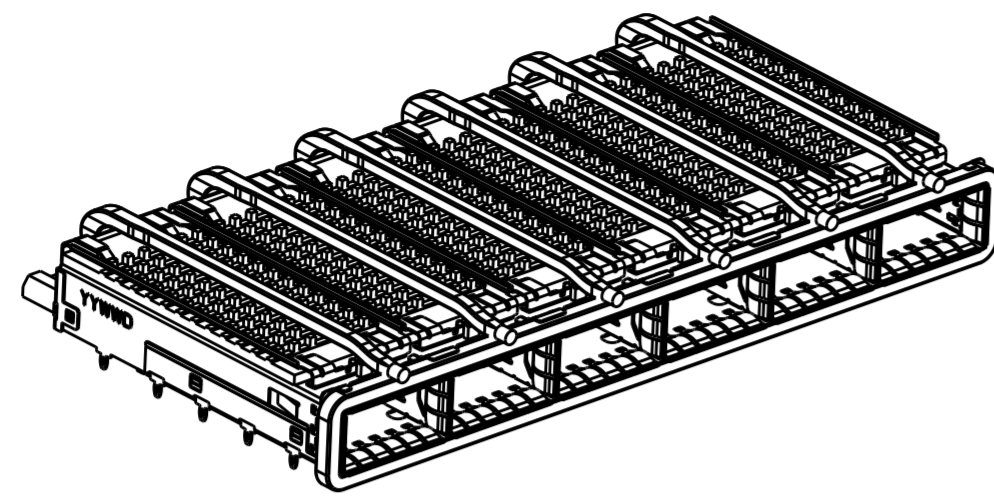

PCI HEAT SINK
SCALE 1:1

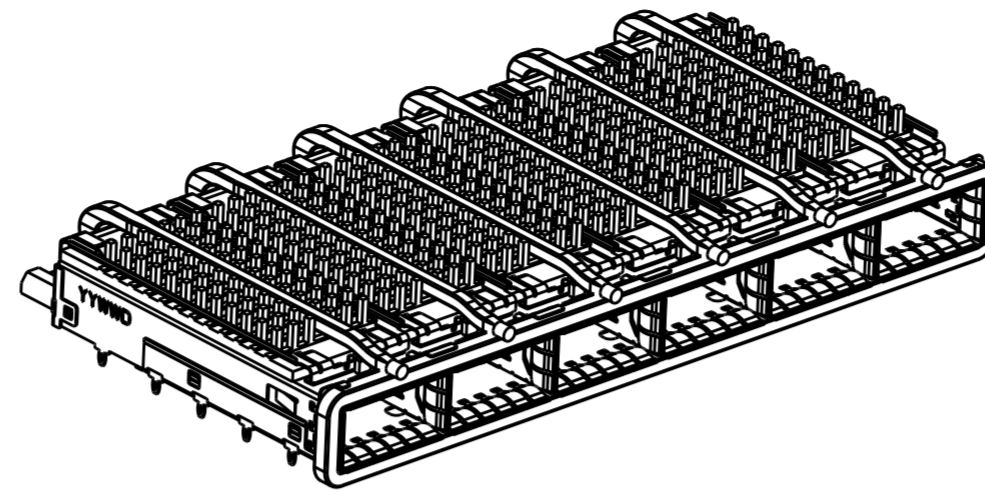

SAN HEAT SINK
SCALE 1:1

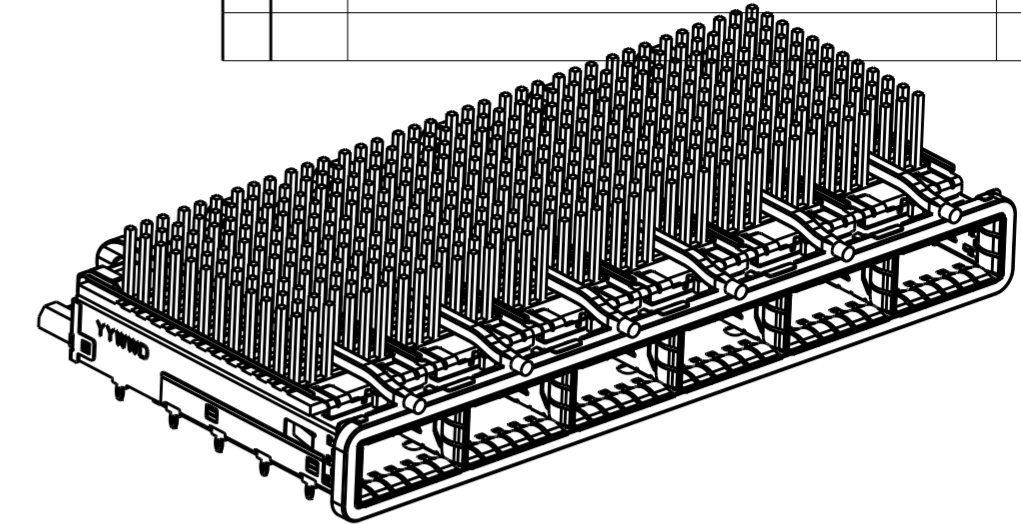

NETWORKING HEAT SINK
SCALE 1:1

LIGHT PIPE OPTION

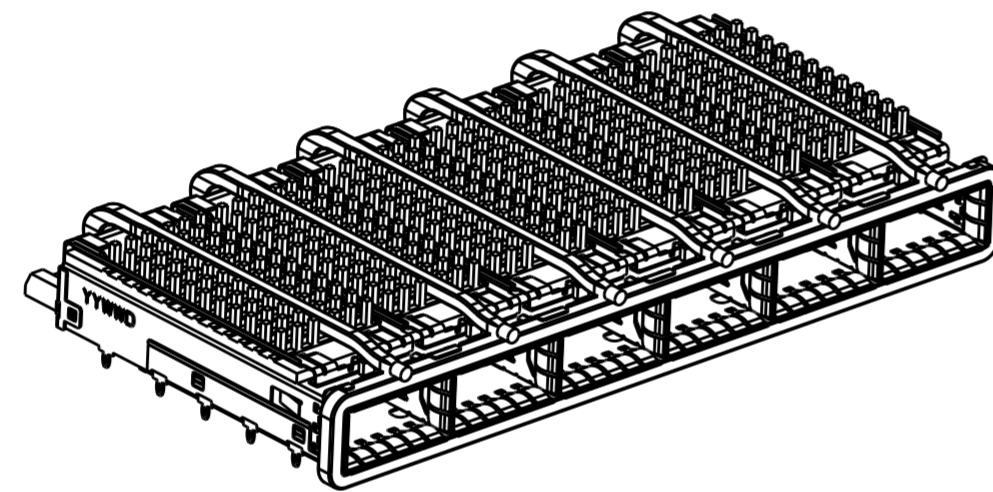

SINGLE LIGHT PIPE
SCALE 1:1

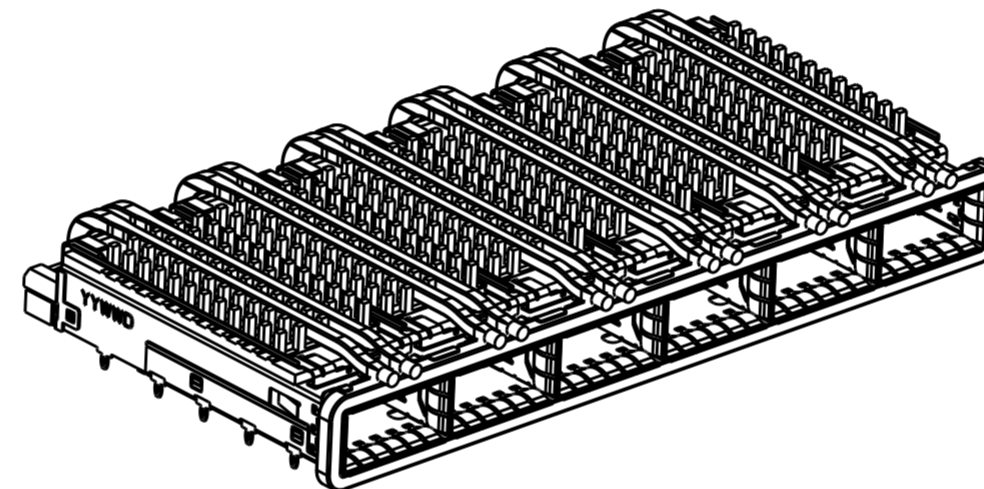

DUAL LIGHT PIPE
SCALE 1:1

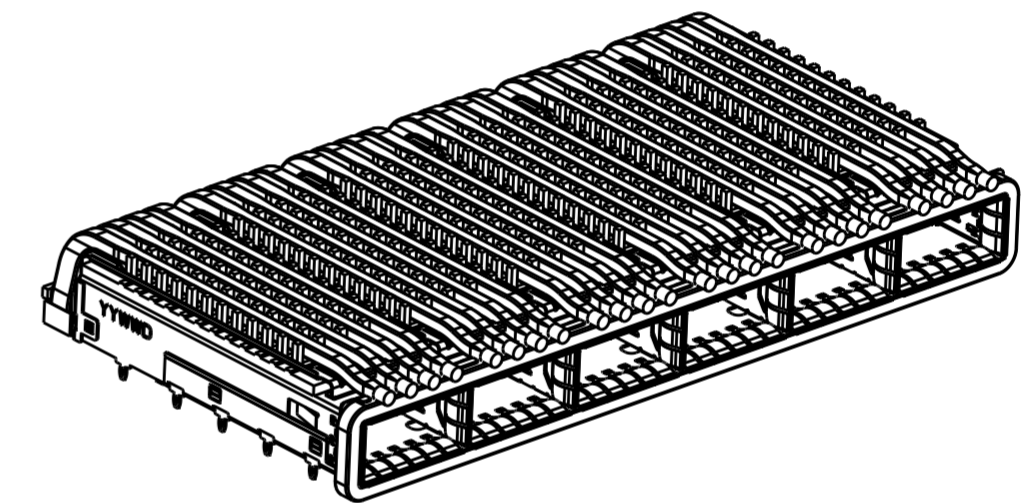

QUAD LIGHT PIPE
SCALE 1:1

OF REAR PIN OPTION

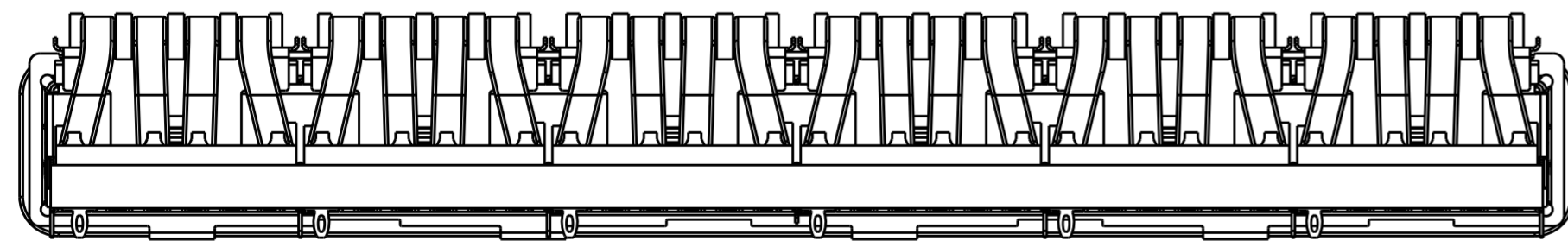

1 REAR PIN
SCALE 2:1

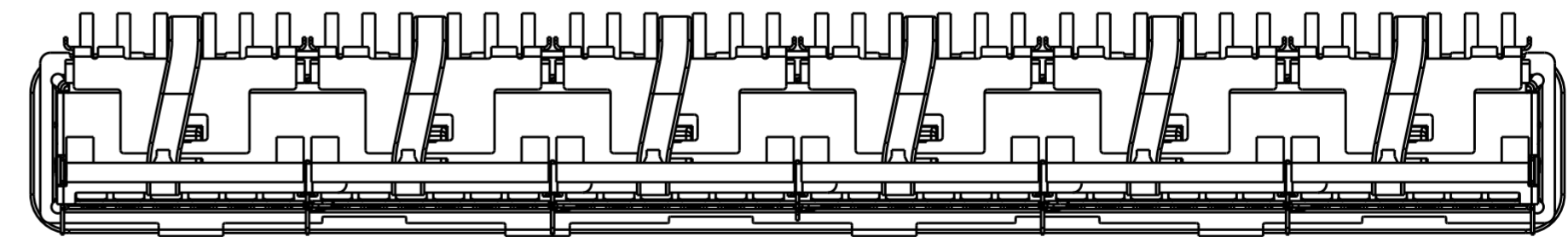

0 REAR PIN
SCALE 2:1

THIS DRAWING IS A CONTROLLED DOCUMENT.		DWN 24OCT2013 JASON YANG	 TE Connectivity	
DIMENSIONS: mm		CHK -		
TOLERANCES UNLESS OTHERWISE SPECIFIED:		PRODUCT SPEC -	NAME CAGE ASSEMBLY, 1X6, QSFP28 WITH HEAT SINKS AND LIGHT PIPES, THRU BEZEL, GASKET	
0 PLC ±- 1 PLC ±0.25 2 PLC ±0.2 3 PLC ±- 4 PLC ±- ANGLES ±- FINISH ±-		APPLICATION SPEC -	SIZE A2	CAGE CODE 00779
MATERIAL SEE NOTES	SEE NOTES	WEIGHT -	DRAWING NO C-2170724	RESTRICTED TO -
		Customer Drawing	SCALE 3:1	SHEET 2 OF 9 REV 1

THIS DRAWING IS UNPUBLISHED. RELEASED FOR PUBLICATION 20
 © COPYRIGHT 20 BY - ALL RIGHTS RESERVED.

REVISIONS				
P	LTR	DESCRIPTION	DATE	APVD
-		SEE SHEET 1	-	-

0	23.0	NETWORKING	QUAD	4-2170724-6
0	16.0	SAN	QUAD	4-2170724-5
0	13.7	PCI	QUAD	4-2170724-4
1	23.0	NETWORKING	QUAD	4-2170724-3
1	16.0	SAN	QUAD	4-2170724-2
1	13.7	PCI	QUAD	4-2170724-1
0	23.0	NETWORKING	DUAL	2-2170724-6
0	16.0	SAN	DUAL	2-2170724-5
0	13.7	PCI	DUAL	2-2170724-4
1	23.0	NETWORKING	DUAL	2-2170724-3
1	16.0	SAN	DUAL	2-2170724-2
1	13.7	PCI	DUAL	2-2170724-1
0	23.0	NETWORKING	SINGLE	2170724-6
0	16.0	SAN	SINGLE	2170724-5
0	13.7	PCI	SINGLE	2170724-4
1	23.0	NETWORKING	SINGLE	2170724-3
1	16.0	SAN	SINGLE	2170724-2
1	13.7	PCI	SINGLE	2170724-1
# OF REAR PIN	DIM A	APPLICATION	LIGHT PIPE OPTION	PART NUMBER

THIS DRAWING IS A CONTROLLED DOCUMENT.		DWN 24OCT2013 JASON YANG	STE TE Connectivity	
DIMENSIONS: mm		CHK - APVD -		
TOLERANCES UNLESS OTHERWISE SPECIFIED: 0 PLC ± 1 PLC ±0.25 2 PLC ±0.2 3 PLC ± 4 PLC ± ANGLES ±		PRODUCT SPEC - APPLICATION SPEC - WEIGHT -	SIZE A200779	DRAWING NO C-2170724
MATERIAL SEE NOTES	FINISH SEE NOTES	Customer Drawing	RESTRICTED TO -	SCALE 3:1 SHEET 3 OF 9 REV 1

THIS DRAWING IS UNPUBLISHED. RELEASED FOR PUBLICATION 20
 © COPYRIGHT 20 BY - ALL RIGHTS RESERVED.

REVISIONS				
P	LTR	DESCRIPTION	DATE	APVD
-	-	SEE SHEET 1	-	-

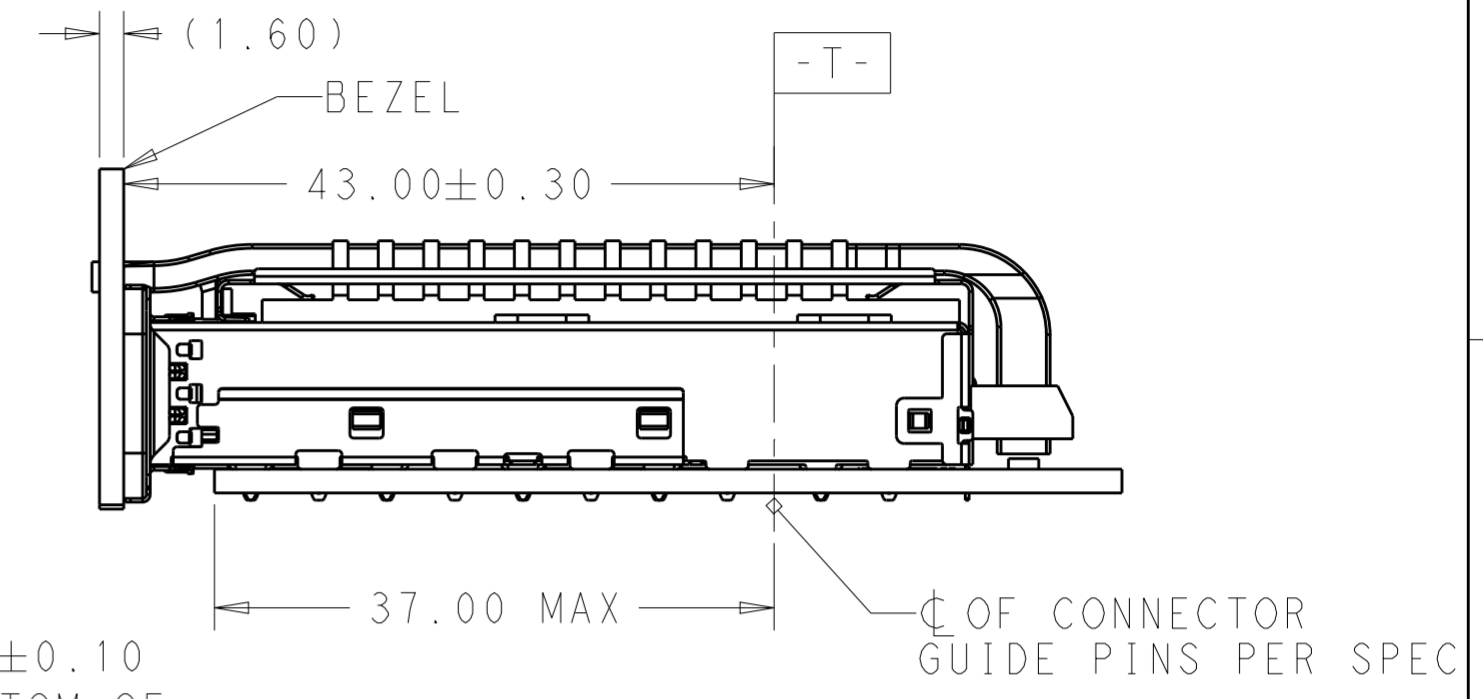
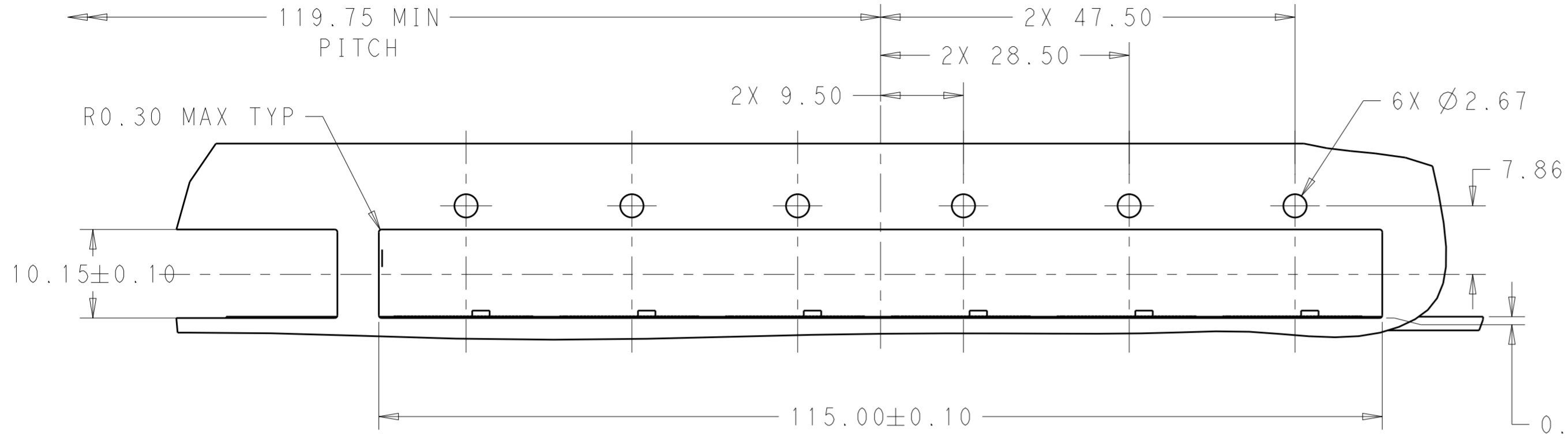

SINGLE SIDE MOUNTING
SCALE 2:1

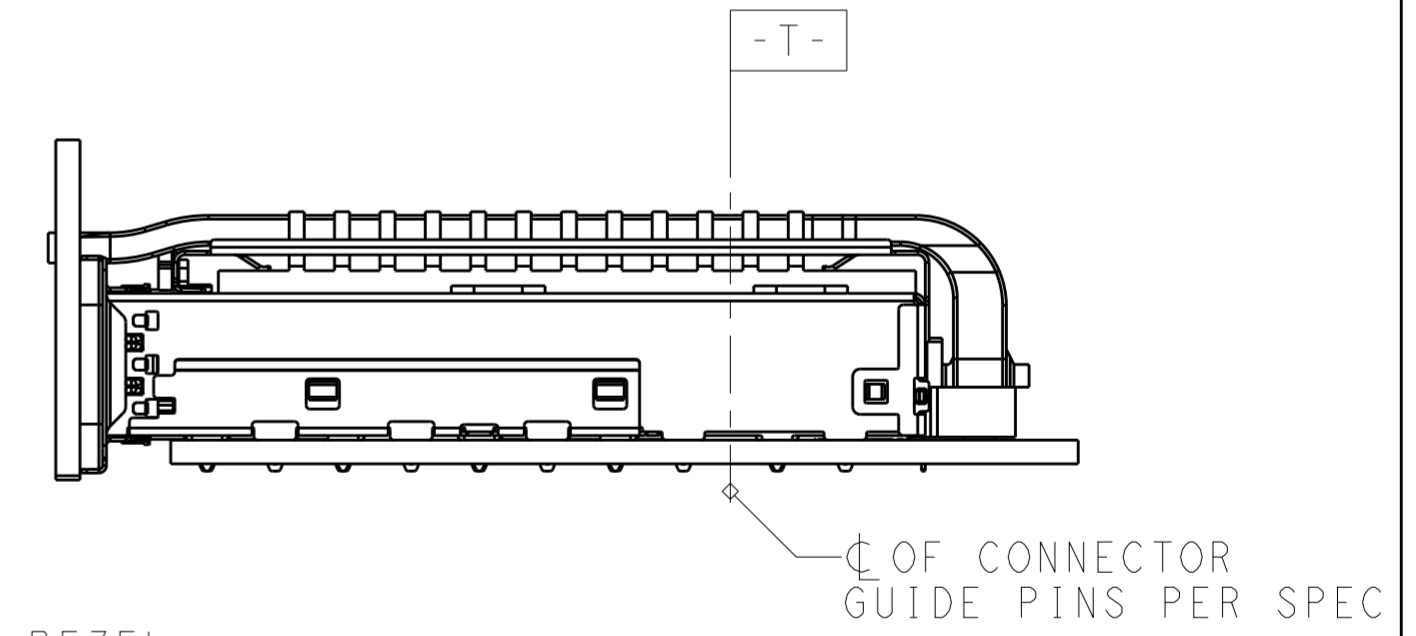
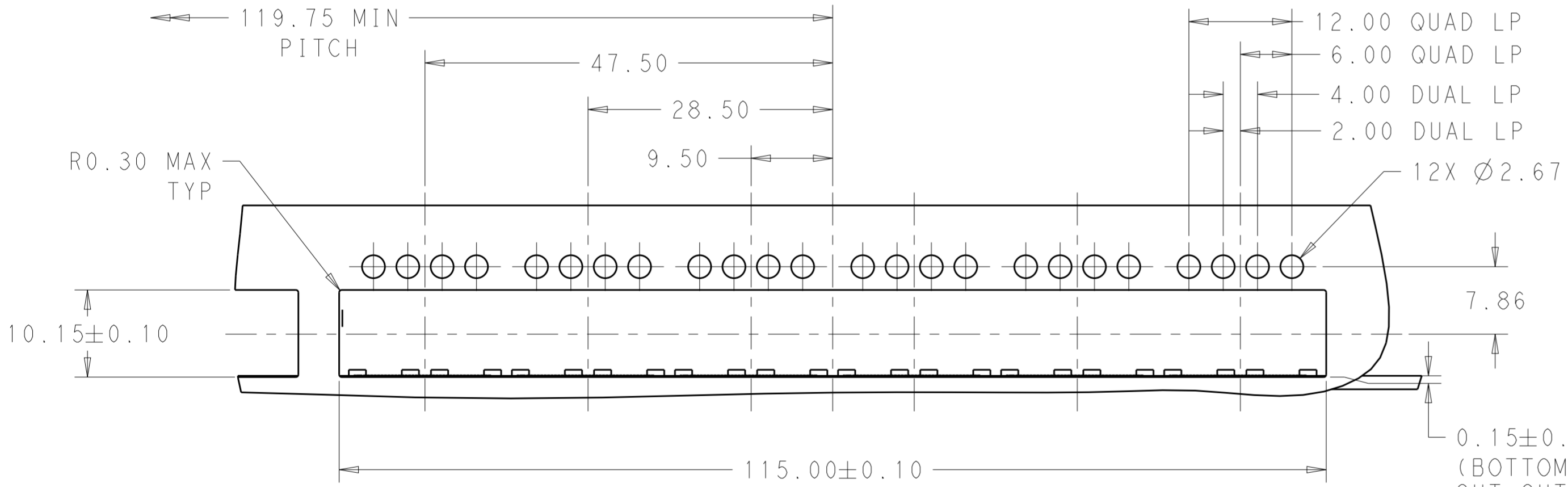

SINGLE SIDE MOUNTING
SCALE 2:1

PRELIMINARY PART- NOT RELEASED FOR PRODUCTION

THIS DRAWING IS A CONTROLLED DOCUMENT.		DWN 24OCT2013 JASON YANG	TE Connectivity	
DIMENSIONS: mm		CHK -		
TOLERANCES UNLESS OTHERWISE SPECIFIED:		APVD -	PRODUCT SPEC	
0 PLC ±		APVD -	APPLICATION SPEC	
1 PLC ±0.25		WEIGHT -	RESTRICTED TO	
2 PLC ±0.2		Customer Drawing	SIZE CAGE CODE DRAWING NO	
3 PLC ±		SCALE 3:1	A200779 C-2170724	
4 PLC ±		SHEET 4 OF 9	REV 1	
ANGLES ±				
FINISH				
MATERIAL SEE NOTES				
SEE NOTES				

THIS DRAWING IS UNPUBLISHED. RELEASED FOR PUBLICATION 20
 © COPYRIGHT 20 BY - ALL RIGHTS RESERVED.

REVISIONS				
P	LTR	DESCRIPTION	DATE	APVD
-	-	SEE SHEET 1	-	-

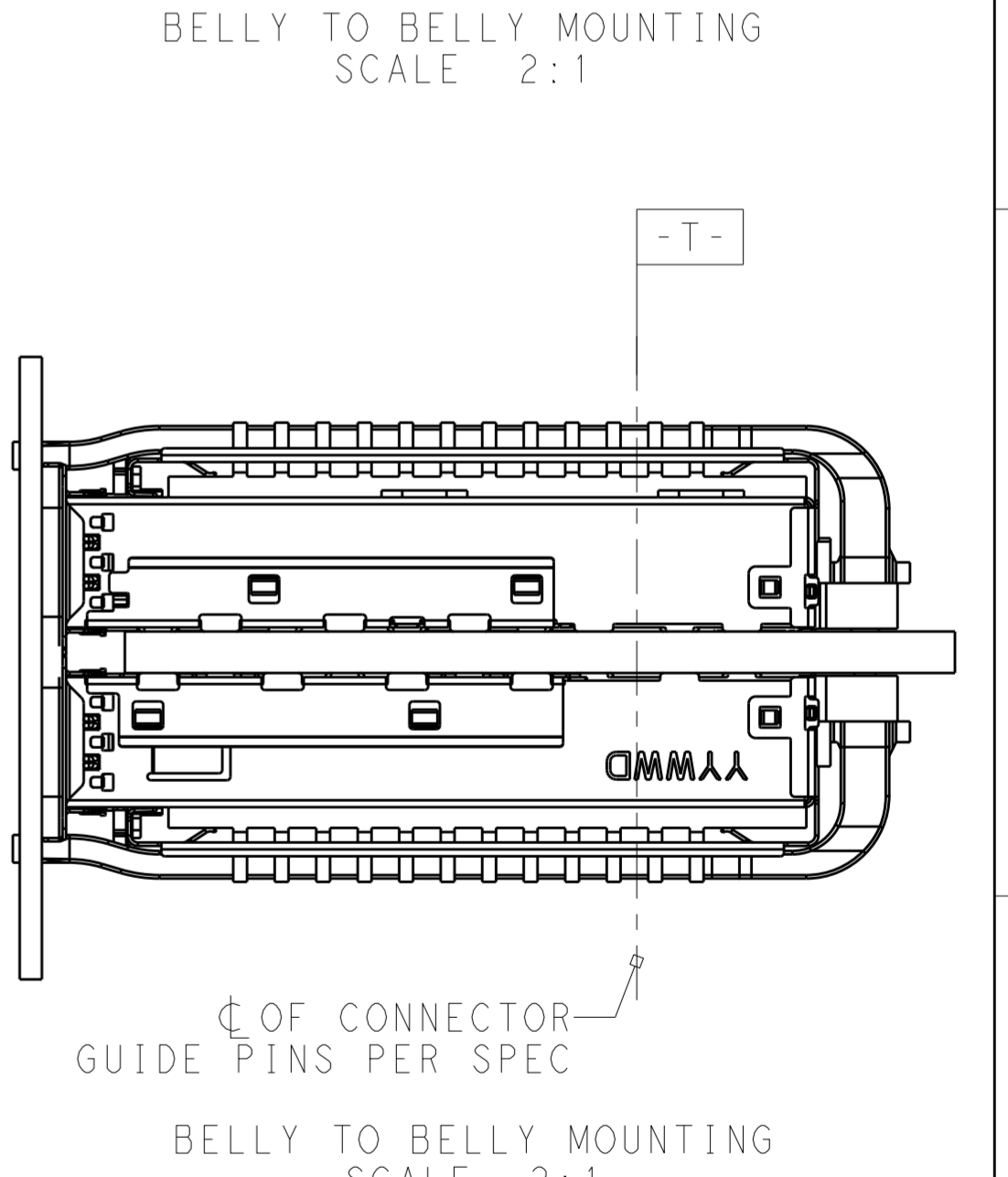
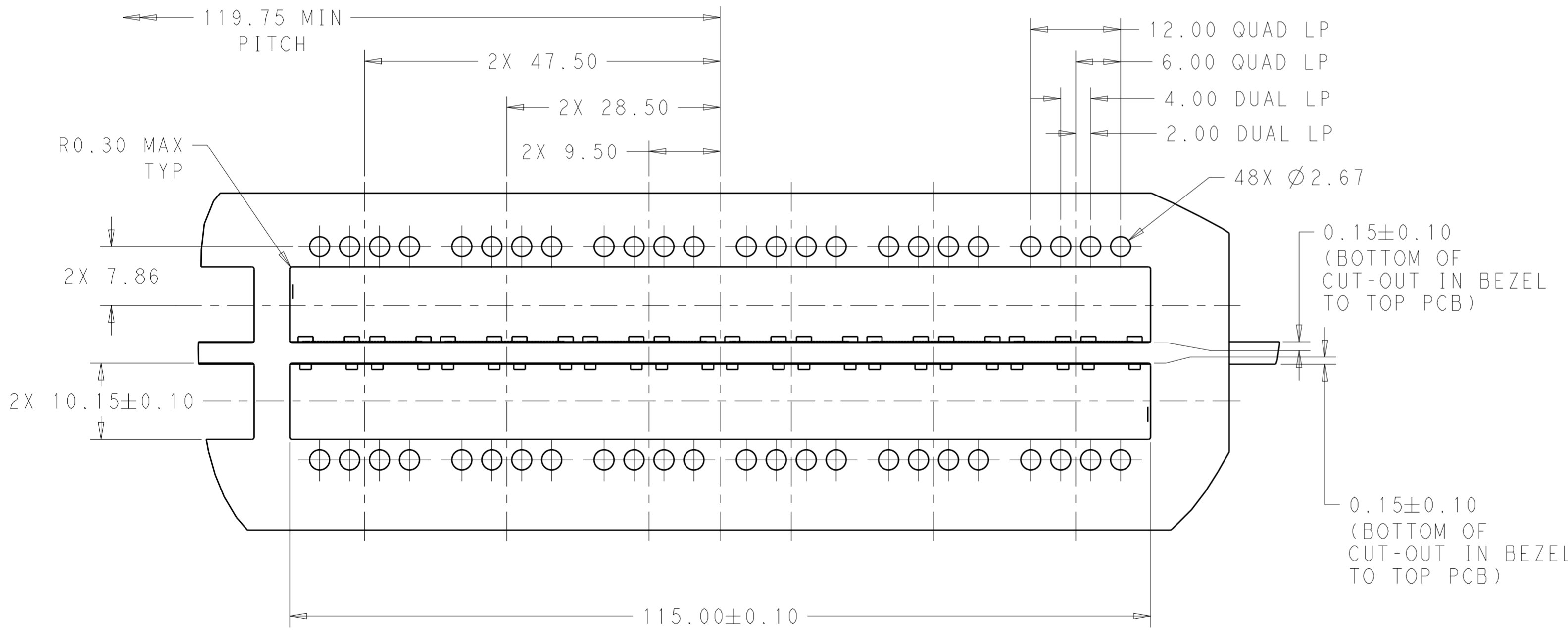
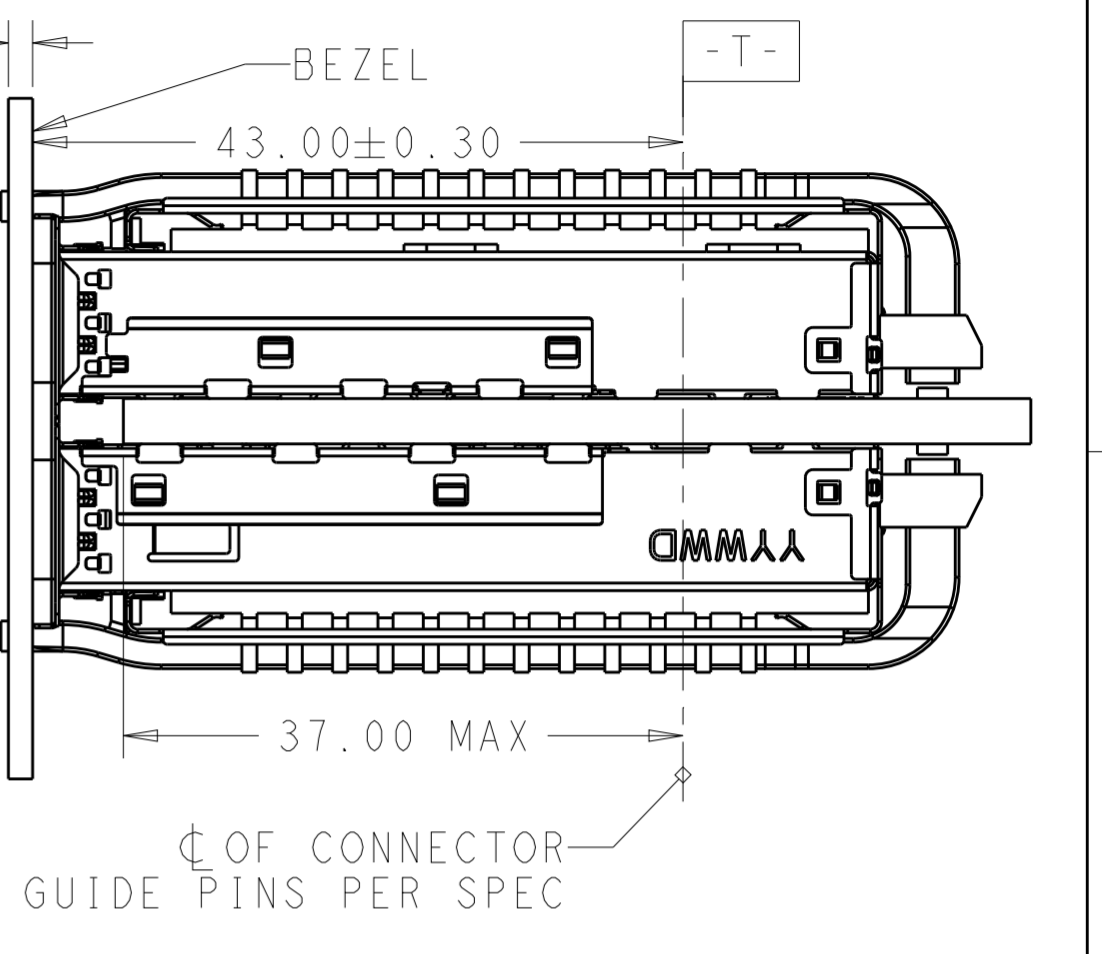
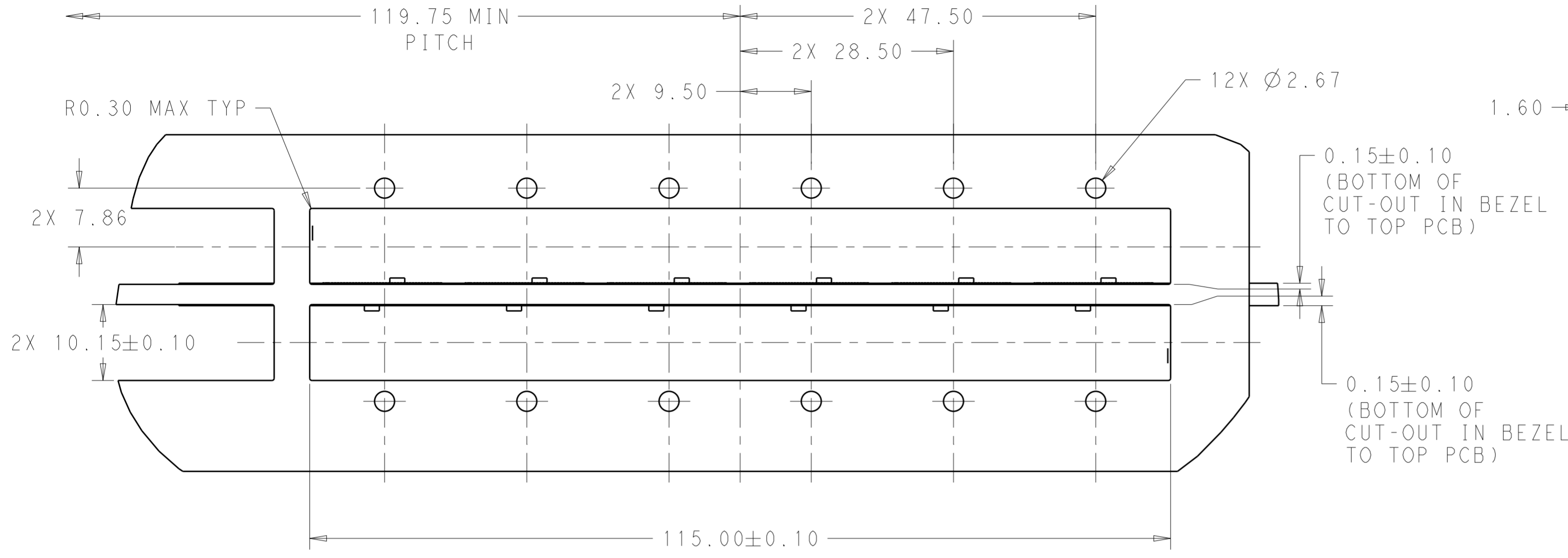

THIS DRAWING IS A CONTROLLED DOCUMENT.		DWN 24OCT2013 JASON YANG	TE Connectivity	
DIMENSIONS: mm		CHK -		
TOLERANCES UNLESS OTHERWISE SPECIFIED:		APVD -	PRODUCT SPEC	
0 PLC ±		APVD -	APPLICATION SPEC	
1 PLC ±0.25		WEIGHT -	SIZE	
2 PLC ±0.2		Customer Drawing	CAGE CODE	
3 PLC ±		SCALE 3:1	DRAWING NO	
4 PLC ±		SHEET 5 OF 9	RESTRICTED TO	
ANGLES ±		REV 1		
FINISH				
MATERIAL SEE NOTES				
SEE NOTES				

THIS DRAWING IS UNPUBLISHED. RELEASED FOR PUBLICATION 20
 © COPYRIGHT 20 BY - ALL RIGHTS RESERVED.

REVISIONS				
P	LTR	DESCRIPTION	DATE	APVD
-	-	SEE SHEET 1	-	-

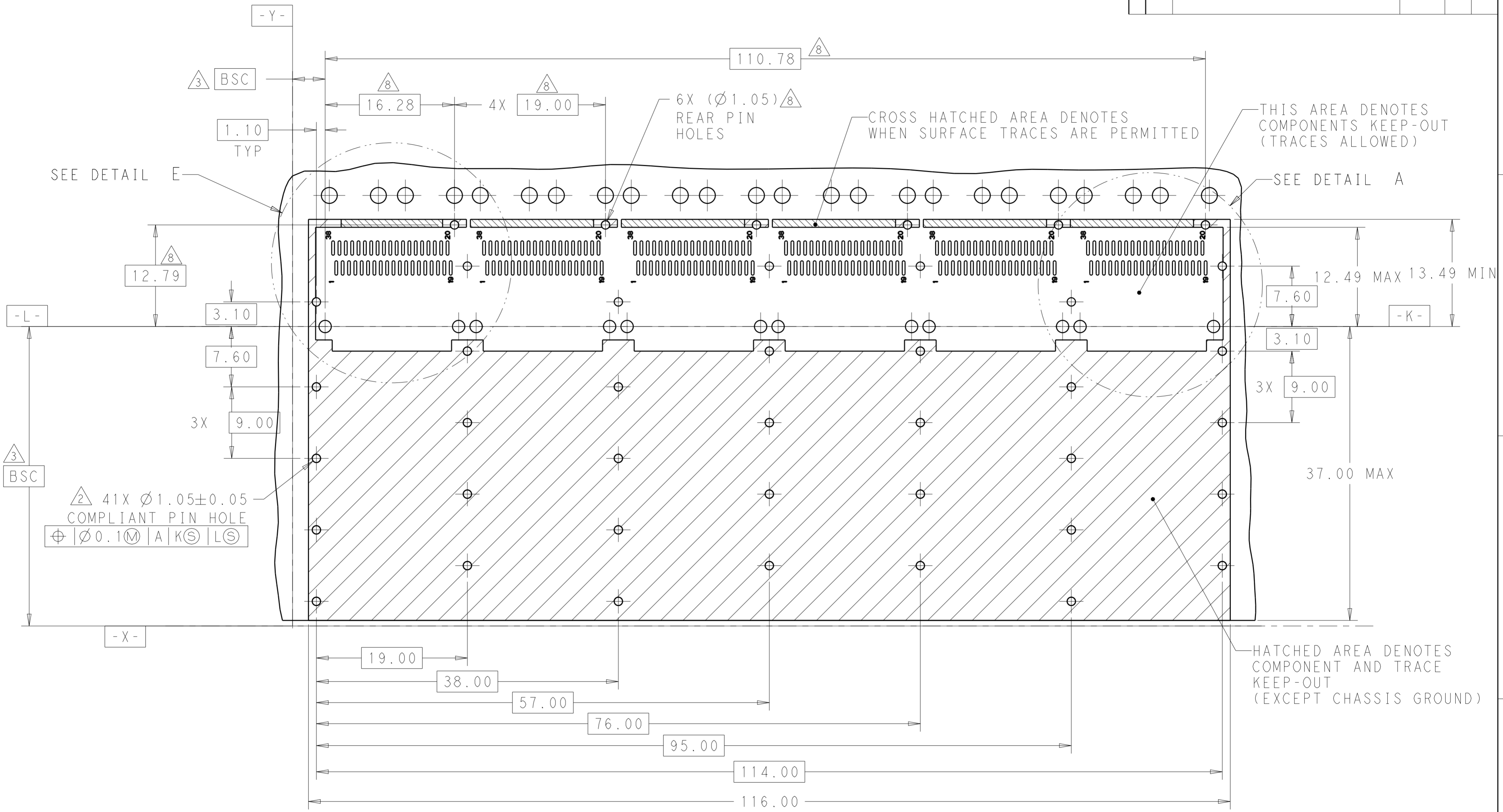

RECOMMENDED PCB LAYOUT
 SINGLE TYPE
 PCB TOLERANCE: ±0.05
 SCALE 3:1

THIS DRAWING IS A CONTROLLED DOCUMENT.		DWN 24OCT2013 JASON YANG	TE Connectivity	
DIMENSIONS: mm		CHK -		
TOLERANCES UNLESS OTHERWISE SPECIFIED:		APVD -	PRODUCT SPEC	CAGE ASSEMBLY, 1X6, QSFP28 WITH HEAT SINKS AND LIGHT PIPES, THRU BEZEL, GASKET
0 PLC ±-	1 PLC ±0.25	PRODUCT SPEC	APPLICATION SPEC	RESTRICTED TO
2 PLC ±0.2	3 PLC ±-	APPLICATION SPEC	SIZE	A200779
4 PLC ±-	ANGLES ±-	WEIGHT	CAGE CODE	C-2170724
MATERIAL SEE NOTES	FINISH SEE NOTES	Customer Drawing	DRAWING NO	REV 1
		SCALE 3:1	SHEET 6 OF 9	

THIS DRAWING IS UNPUBLISHED. RELEASED FOR PUBLICATION 20
 © COPYRIGHT 20 BY - ALL RIGHTS RESERVED.

REVISIONS				
P	LTR	DESCRIPTION	DATE	APVD
-	-	SEE SHEET 1	-	-

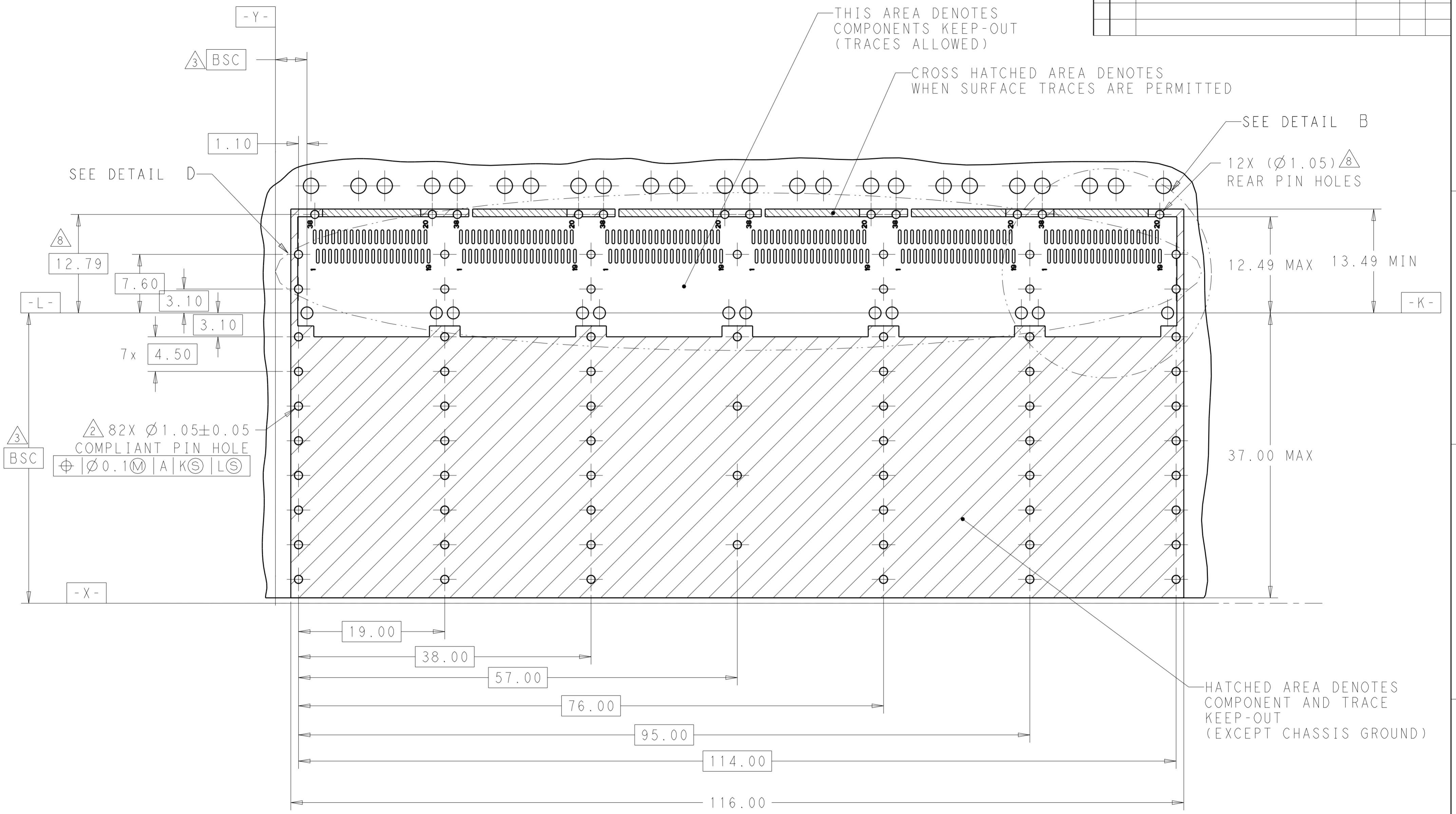

RECOMMENDED PCB LAYOUT
 BELLY TO BELLY TYPE
 PCB TOLERANCE: ±0.05
 SCALE 3:1

PRELIMINARY PART- NOT RELEASED FOR PRODUCTION

THIS DRAWING IS A CONTROLLED DOCUMENT.		DWN 24OCT2013 JASON YANG	TE Connectivity	
DIMENSIONS: mm		CHK -		
TOLERANCES UNLESS OTHERWISE SPECIFIED:		APVD -	PRODUCT SPEC	
0 PLC ±	1 PLC ±0.25	APPLICATION SPEC	CAGE CODE	
2 PLC ±0.2	3 PLC ±	WEIGHT	DRAWING NO	
4 PLC ±	ANGLES ±	Customer Drawing	RESTRICTED TO	
FINISH	SEE NOTES	SCALE 3:1	SHEET 7 OF 9	
MATERIAL SEE NOTES	SEE NOTES	Customer Drawing	REV 1	

THIS DRAWING IS UNPUBLISHED. RELEASED FOR PUBLICATION 20
 © COPYRIGHT 20 BY - ALL RIGHTS RESERVED.

REVISIONS				
P	LTR	DESCRIPTION	DATE	APVD
-	-	SEE SHEET 1	-	-

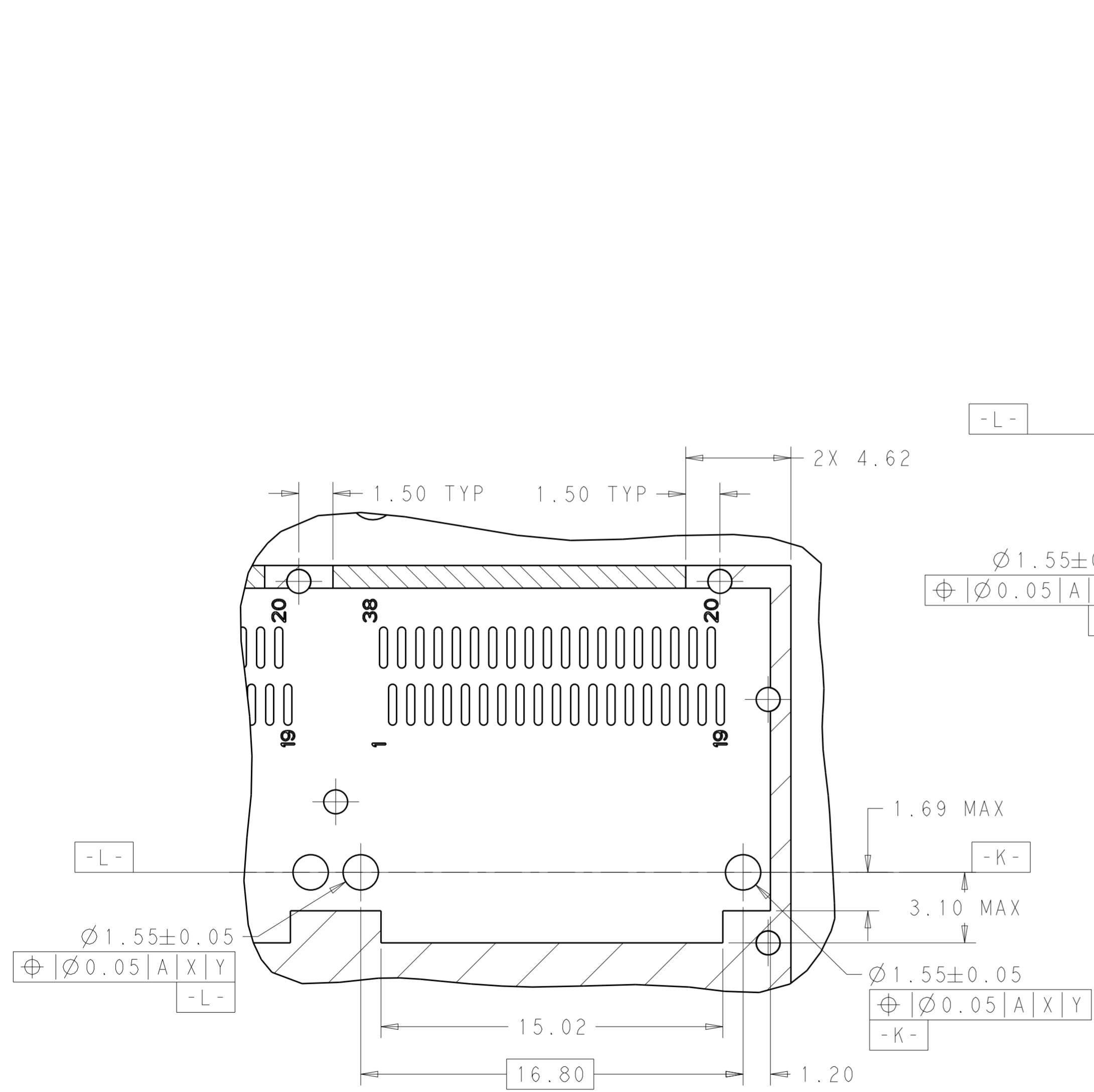

DETAIL A
SCALE 6:1

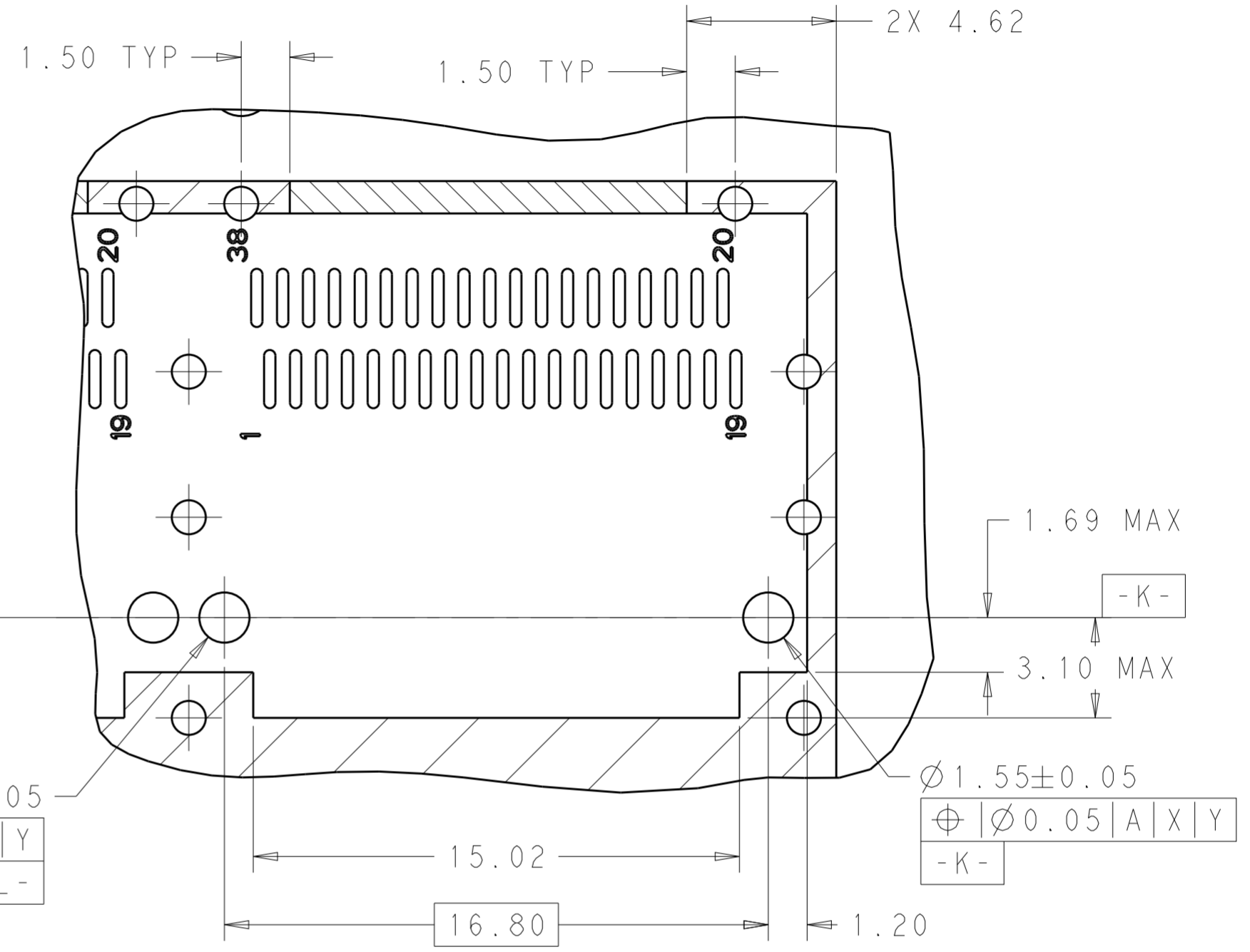

DETAIL B
SCALE 6:1

PRELIMINARY PART- NOT RELEASED FOR PRODUCTION

THIS DRAWING IS A CONTROLLED DOCUMENT.		DWN 24OCT2013 JASON YANG	TE Connectivity	
DIMENSIONS: mm		CHK -		
TOLERANCES UNLESS OTHERWISE SPECIFIED:		APVD -	PRODUCT SPEC	
0 PLC ±	1 PLC ±0.25	APPLICATION SPEC	CAGE ASSEMBLY, 1X6, QSFP28 WITH HEAT SINKS AND LIGHT PIPES, THRU BEZEL, GASKET	
2 PLC ±0.2	3 PLC ±	WEIGHT	SIZE CAGE CODE DRAWING NO RESTRICTED TO	
4 PLC ±	ANGLES ±	Customer Drawing	A200779 C-2170724	
MATERIAL SEE NOTES	FINISH SEE NOTES	SCALE 3:1	SHEET 8 OF 9	
		REV 1		

THIS DRAWING IS UNPUBLISHED. RELEASED FOR PUBLICATION 20
 © COPYRIGHT 20 BY - ALL RIGHTS RESERVED.

REVISIONS				
P	LTR	DESCRIPTION	DATE	APVD
-	-	SEE SHEET 1	-	-

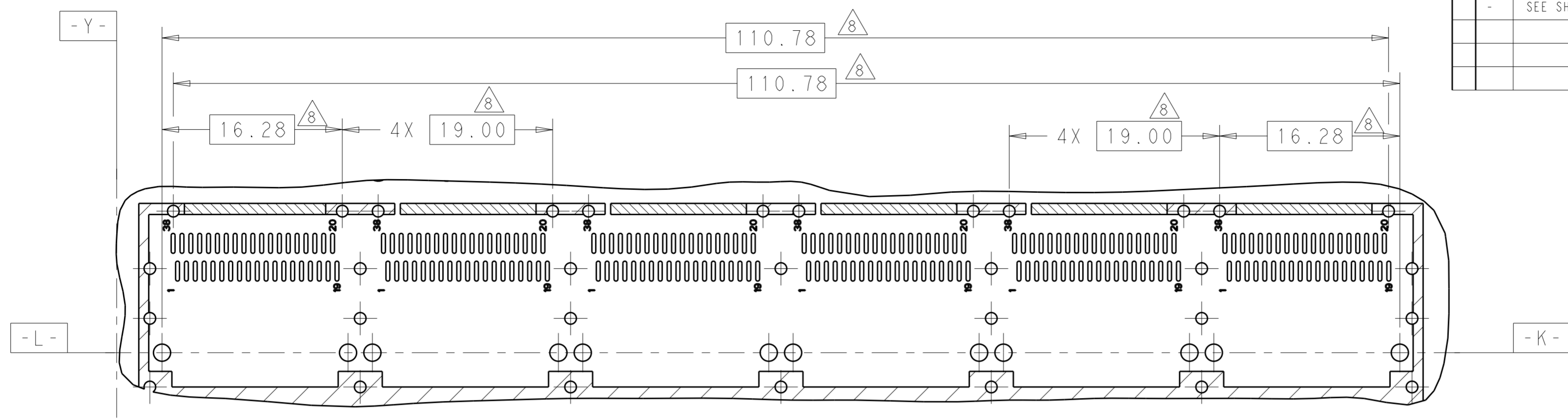

DETAIL D
SCALE 3:1

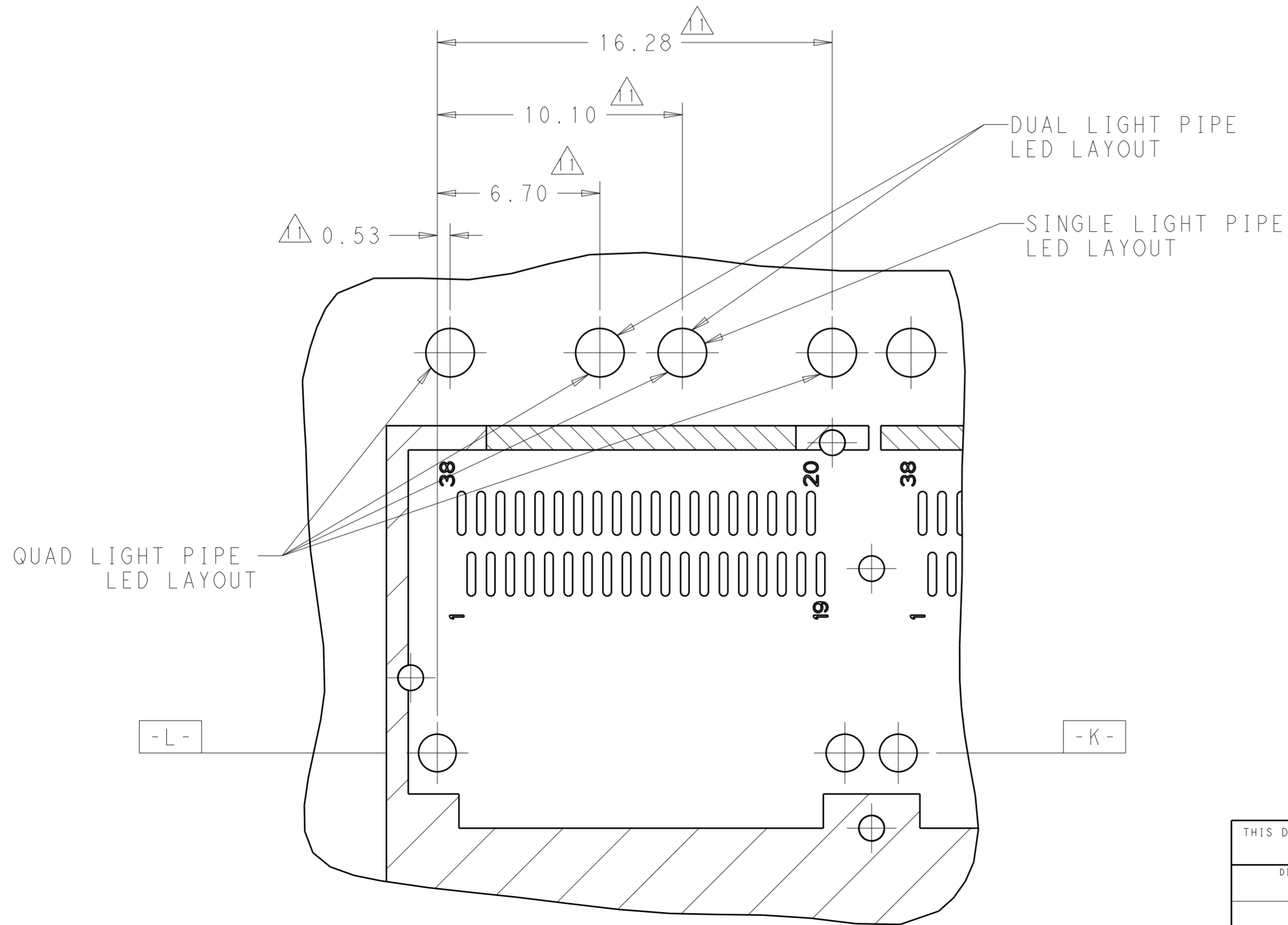

DETAIL E
SCALE 6:1

THIS DRAWING IS A CONTROLLED DOCUMENT.		DWN 24OCT2013 JASON YANG	TE Connectivity	
DIMENSIONS: mm		CHK -		
TOLERANCES UNLESS OTHERWISE SPECIFIED:		APVD -	PRODUCT SPEC	CAGE ASSEMBLY, 1X6, QSFP28 WITH HEAT SINKS AND LIGHT PIPES, THRU BEZEL, GASKET
0 PLC ±		APVD -	APPLICATION SPEC	RESTRICTED TO
1 PLC ±0.25		WEIGHT -	SIZE	A200779
2 PLC ±0.2		Customer Drawing	CAGE CODE	C-2170724
3 PLC ±		SCALE 3:1	DRAWING NO	9 OF 9
4 PLC ±		SHEET 9 OF 9	REV 1	
ANGLES ±				
FINISH				
MATERIAL SEE NOTES				
SEE NOTES				