



# Dynamic Pressure Sensors

## Model 765M25 765M27

The Models 765M25 and 765M27 High Intensity Acoustic Sensors (Microphones) are designed for the measurement of gas-borne sound in industrial applications. These sensors have been constructed for use in corrosive environments that are compatible with the type 316 stainless steel diaphragm. The two designs differ only in their electrical connections. The Model 765M25 incorporates a miniature 10-32 fused-glass coaxial connector, and Model 765M27 provides a 2-pin connector interface. When combined with their all-welded construction, both units provide a true hermetic seal.

Electrically, these devices comprise sensing elements of piezoceramic material in a balanced and floating configuration to provide enhanced rejection of electrical noise associated with many industrial environments. Optimum performance is achieved when used with a true differential input amplifier. *Consult the factory for customized versions of this sensor.*

- High Sensitivity (1200 pC/psi)
- High Temperature To +500 Deg F
- Electrically Isolated
- Choice of Electrical Interface

### Specifications

Transfer / Electrical	765M25	765M27
Charge Sensitivity	1200 +/-200 pC/psi	
Frequency Response	2 Hz To 8,000 Hz	
Dynamic Range	0.28 x 10 <sup>-4</sup> to 10 psi (191 dB SPL Max.)	
Avg Temp Coeff of Sensitivity	0.08% / Deg F Nominal	
Transducer Capacitance	6,300 pF +/-10%	
Insulation Resistance	100 Megohms Min., 50 VDC Test	
Isolation Resistance	100 Megohms Min., 50 VDC Test	
Dielectric Strength	550 Vrms, 60 Hz, Element to Housing	
<b>Environmental</b>		
Vibration Limit	100 g Max. (Sine)	
Shock Limit	1,000 g Max., 0.25 mSec	
Temperature Range	-10 To +500 Deg F (-23 To +260 Deg C)	
Humidity <sup>1</sup>	0 To 100% R.H.	
Static Pressure	3,000 psi Max. (Diaphragm)	
Electromagnetic Sensitivity	0.005 g (Equiv / 100 Gauss)	
<b>Physical</b>		
Configuration	Balanced Floating Compression	
Size		
Model 765M25	1.375 In. Hex. x 1.88 In. H (35.0 mm Hex x 47.8 mm H)	
Model 765M27	1.375 In. Hex. x 2.10 In. H (35.0 mm Hex. x 53.34 mm H)	
Weight	7.0 Oz (200 Gm)	
Material	Type 316 Stainless Steel	
Body & Diaphragm	Type 316 Stainless Steel	
Electrical Interface	Isolated 10-32 Coaxial Connector	2-Pin MIL-C-5015 Style Connector
Mounting	1.125 – 12 UNF-2A Straight Thread	

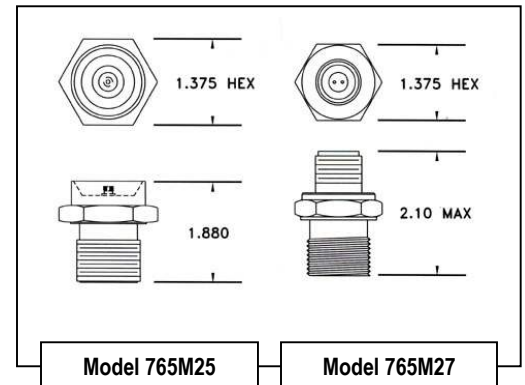

### Accessories Supplied:

- (1) Low Noise Cable Assembly (3M) (300 pF) - Model 765M25 Only
- (1) Hardwood Storage Case
- (1) Standard Calibration Data

### NOTES:

<sup>1</sup> With Connector Mated or Protected, Unit is Hermetically Sealed.

R12605

**Columbia Research Laboratories, Inc. 1925 Mac Dade Blvd. Woodlyn, PA 19094 USA**  
**Phone: 1.800.813.8471 / Fax: 610.872.3882 / email: sales@columbiaresearchlab.com**