



New Product Announcement

Automotive Grade
SMAJ/SMBJ/SMCJ/
3.0SMCJ TVS

Automotive Grade SMAJ/SMBJ/SMCJ/3.0SMCJ TVS

Diodes Incorporated is introducing a range of 84 new automotive-compliant transient voltage suppressors (TVS) packaged in a choice of SMA, SMB or SMC packages.

Designed to protect sensitive electronic circuits from powerline transients generated by inductive switching, these devices target a wide range of automotive applications including pumps, HVAC, infotainment, navigation and ADAS.

Featuring a choice of reverse stand-off voltage from 14V to 36V these new automotive-compliant TVS are offered as unidirectional or bidirectional devices and are able to dissipate up to 400W (SMA), 600W (SMB) and 3000W (SMC) per 10/1000 μ s pulse transient.

All devices comply with the automotive load dump standard ISO7637-2 (pulses 1, 2a, 2b, 3) and ESD standard ISO10605.



The Diodes Advantage

- **AEC-Q101 Qualified and PPAP Supported**

These devices are qualified to high reliability qualification standards in accordance with AEC-Q101 and supported by a production part approval procedure (PPAP).

- **ISO 10605 Compliance**

These parts are suitable to protect sensitive automotive circuits against electrostatic discharges according to ISO10605.

- **ISO 7637-2 Compliance**

These parts are suitable to protect sensitive automotive circuits against surges defined in ISO7637-2 (pulses 1, 2a, 2b and 3).

- **High Forward Surge Current Capability and Excellent Clamping Capability**

The high forward surge overload rating and excellent clamping capability ensures more rugged applications and improves device reliability.

Applications

- Advanced Driver Assistance Systems (ADAS)
- Infotainment
- Navigation
- HVAC (Heating, Ventilation & Air Conditioning)
- Body Control Modules



New Product Announcement

Automotive Grade
SMAJ/SMBJ/SMCJ/
3.0SMCJ TVS

Circuit Function

Powerline protection of automotive Electronic Control Units (ECU) is important to avoid surge voltages, generated by the alternator or other inductive loads (motors), passing through to sensitive electronics. Thus powerline protection is required for almost all automotive electronics.

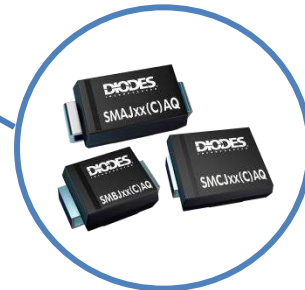
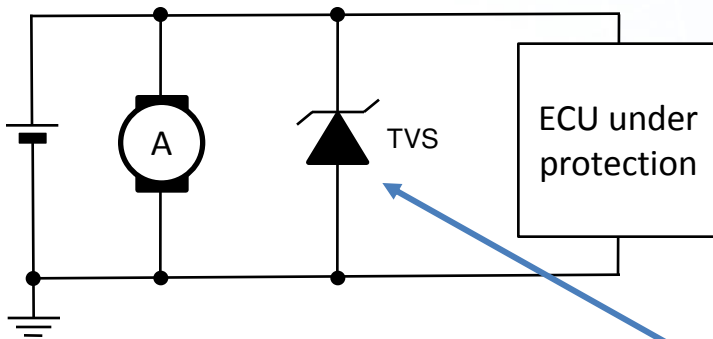

Package Outline Dimensions

| SMA | | |
|----------------------|------|------|
| Dim | Min | Max |
| A | 2.29 | 2.92 |
| B | 4.00 | 4.60 |
| C | 1.27 | 1.63 |
| D | 0.15 | 0.31 |
| E | 4.80 | 5.59 |
| G | 0.05 | 0.20 |
| H | 0.76 | 1.52 |
| J | 1.96 | 2.40 |
| All Dimensions in mm | | |

| SMB | | |
|----------------------|------|------|
| Dim | Min | Max |
| A | 3.30 | 3.94 |
| B | 4.06 | 4.57 |
| C | 1.96 | 2.21 |
| D | 0.15 | 0.31 |
| E | 5.00 | 5.59 |
| G | 0.05 | 0.20 |
| H | 0.76 | 1.52 |
| J | 2.00 | 2.50 |
| All Dimensions in mm | | |

| SMC | | |
|----------------------|------|------|
| Dim | Min | Max |
| A | 5.59 | 6.22 |
| B | 6.60 | 7.11 |
| C | 2.75 | 3.18 |
| D | 0.15 | 0.31 |
| E | 7.75 | 8.13 |
| G | 0.10 | 0.20 |
| H | 0.76 | 1.52 |
| J | 2.00 | 2.50 |
| All Dimensions in mm | | |

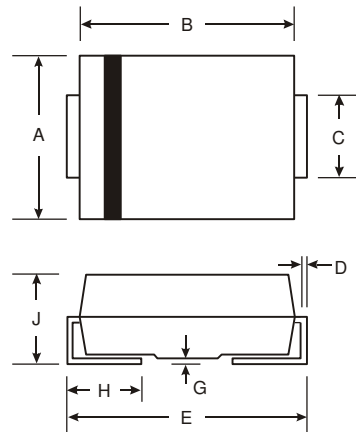



New Product Announcement

Automotive Grade
SMAJ/SMBJ/SMCJ/
3.0SMCJ TVS

Product Portfolio

| Part Number | Reverse Standoff Voltage VRWM | Breakdown Voltage VBR @ I _T | | Max. Reverse Leakage @ V | Max. Clamping Voltage @ I _{pp} | Max. Peak Pulse Current I _{pp} | Competitor near Equivalent |
|-------------|-------------------------------|--|---------|--------------------------|---|---|---|
| | (V) | Min (V) | Max (V) | IR(μA) | Vc(V) | (A) | |
| SMAJ14(C)AQ | 14 | 15.6 | 17.2 | 5.0 | 23.2 | 17.2 | SZ1SMA14(C)AT3G, SMAJ14(C)AHM3/I, SMAJ14(C)AHE2G |
| SMAJ15(C)AQ | 15 | 16.7 | 18.5 | 5.0 | 24.4 | 16.4 | SZ1SMA15(C)AT3G, SMAJ15(C)AHM3/I, SMAJ15(C)AHE2G |
| SMAJ16(C)AQ | 16 | 17.8 | 19.7 | 5.0 | 26.0 | 15.3 | SZ1SMA16(C)AT3G, SMAJ16(C)AHM3/I, SMAJ16(C)AHE2G |
| SMAJ17(C)AQ | 17 | 18.9 | 20.9 | 5.0 | 27.6 | 14.5 | SZ1SMA17(C)AT3G, SMAJ17(C)AHM3/I, SMAJ17(C)AHE2G |
| SMAJ18(C)AQ | 18 | 20.0 | 22.1 | 5.0 | 29.2 | 13.7 | SZ1SMA18(C)AT3G, SMAJ18(C)AHM3/I, SMAJ18(C)AHE2G, SM4TY21(C)AY |
| SMAJ20(C)AQ | 20 | 22.2 | 24.5 | 5.0 | 32.4 | 12.3 | SZ1SMA20(C)AT3G, SMAJ20(C)AHM3/I, SMAJ20(C)AHE2G, SM4TY23(C)AY |
| SMAJ22(C)AQ | 22 | 24.4 | 26.9 | 5.0 | 35.5 | 11.2 | SZ1SMA22(C)AT3G, SMAJ22(C)AHM3/I, SMAJ22(C)AHE2G, SM4TY26(C)AY |
| SMAJ24(C)AQ | 24 | 26.7 | 29.5 | 5.0 | 38.9 | 10.3 | SZ1SMA24(C)AT3G, SMAJ24(C)AHM3/I, SMAJ24(C)AHE2G, SM4TY28(C)AY |
| SMAJ26(C)AQ | 26 | 28.9 | 31.9 | 5.0 | 42.1 | 9.5 | SZ1SMA26(C)AT3G, SMAJ26(C)AHM3/I, SMAJ26(C)AHE2G, SM4TY30(C)AY |
| SMAJ28(C)AQ | 28 | 31.1 | 34.4 | 5.0 | 45.4 | 8.8 | SZ1SMA28(C)AT3G, SMAJ28(C)AHM3/I, SMAJ28(C)AHE2G, SM4TY33(C)AY |
| SMAJ30(C)AQ | 30 | 33.3 | 36.8 | 5.0 | 48.4 | 8.3 | SZ1SMA30(C)AT3G, SMAJ30(C)AHM3/I, SMAJ30(C)AHE2G, SM4TY35(C)AY |
| SMAJ33(C)AQ | 33 | 36.7 | 40.6 | 5.0 | 53.3 | 7.5 | SZ1SMA33(C)AT3G, SMAJ33(C)AHM3/I, SMAJ33(C)AHE2G, SM4TY39(C)AY |
| SMAJ36(C)AQ | 36 | 40.0 | 44.2 | 5.0 | 58.1 | 6.9 | SZ1SMA36(C)AT3G, SMAJ36(C)AHM3/I, SMAJ36(C)AHE2G |
| SMBJ14(C)AQ | 14.0 | 15.60 | 17.90 | 5.0 | 23.2 | 25.8 | SZ1SMB14(C)AT3G, SMBJ14(C)AHM3/I, SMBJ14(C)AHM4G, SM6T16V5(C)AY |
| SMBJ15(C)AQ | 15.0 | 16.70 | 19.20 | 5.0 | 24.4 | 24.0 | SZ1SMB15(C)AT3G, SMBJ15(C)AHM3/I, SMBJ15(C)AHM4G, SM6TY18(C)AY |
| SMBJ16(C)AQ | 16.0 | 17.80 | 20.50 | 5.0 | 26.0 | 23.1 | SZ1SMB16(C)AT3G, SMBJ16(C)AHM3/I, SMBJ16(C)AHM4G |
| SMBJ17(C)AQ | 17.0 | 18.90 | 21.70 | 5.0 | 27.6 | 21.7 | SZ1SMB17(C)AT3G, SMBJ17(C)AHM3/I, SMBJ17(C)AHM4G |
| SMBJ18(C)AQ | 18.0 | 20.00 | 23.30 | 5.0 | 29.2 | 20.5 | SZ1SMB18(C)AT3G, SMBJ18(C)AHM3/I, SMBJ18(C)AHM4G, SM6TY22(C)AY |
| SMBJ20(C)AQ | 20.0 | 22.20 | 25.50 | 5.0 | 32.4 | 18.5 | SZ1SMB20(C)AT3G, SMBJ20(C)AHM3/I, SMBJ20(C)AHM4G |
| SMBJ22(C)AQ | 22.0 | 24.40 | 28.00 | 5.0 | 35.5 | 16.9 | SZ1SMB22(C)AT3G, SMBJ22(C)AHM3/I, SMBJ22(C)AHM4G |
| SMBJ24(C)AQ | 24.0 | 26.70 | 30.70 | 5.0 | 38.9 | 15.4 | SZ1SMB24(C)AT3G, SMBJ24(C)AHM3/I, SMBJ24(C)AHM4G |
| SMBJ26(C)AQ | 26.0 | 28.90 | 33.20 | 5.0 | 42.1 | 14.2 | SZ1SMB26(C)AT3G, SMBJ26(C)AHM3/I, SMBJ26(C)AHM4G |
| SMBJ28(C)AQ | 28.0 | 31.10 | 35.80 | 5.0 | 45.4 | 13.2 | SZ1SMB28(C)AT3G, SMBJ28(C)AHM3/I, SMBJ28(C)AHM4G |
| SMBJ30(C)AQ | 30.0 | 33.30 | 38.30 | 5.0 | 48.4 | 12.4 | SZ1SMB30(C)AT3G, SMBJ30(C)AHM3/I, SMBJ30(C)AHM4G |
| SMBJ33(C)AQ | 33.0 | 36.70 | 42.20 | 5.0 | 53.3 | 11.3 | SZ1SMB33(C)AT3G, SMBJ33(C)AHM3/I, SMBJ33(C)AHM4G, SM6TY39(C)AY |
| SMBJ36(C)AQ | 36.0 | 40.00 | 46.00 | 5.0 | 58.1 | 10.3 | SZ1SMB36(C)AT3G, SMBJ36(C)AHM3/I, SMBJ36(C)AHM4G |



New Product Announcement

Automotive Grade
SMAJ/SMBJ/SMCJ/
3.0SMCJ TVS

Product Portfolio Continued

| Part Number | Reverse Standoff Voltage VRWM | Breakdown Voltage VBR @ I _T | | Max. Reverse Leakage @ V | Max. Clamping Voltage @ I _{pp} | Max. Peak Pulse Current I _{pp} | Competitor near Equivalent |
|-------------|-------------------------------|--|---------|--------------------------|---|---|--|
| | (V) | Min (V) | Max (V) | IR(μA) | V _c (V) | (A) | |
| SMCJ14(C)AQ | 14.0 | 15.60 | 17.2 | 5.0 | 23.2 | 64.7 | SMCJ14(C)AHM3/I, SMCJ14(C)AHR6G |
| SMCJ15(C)AQ | 15.0 | 16.70 | 18.5 | 5.0 | 24.4 | 61.5 | SMCJ15(C)AHM3/I, SMCJ15(C)AHV6G |
| SMCJ16(C)AQ | 16.0 | 17.80 | 19.7 | 5.0 | 26.0 | 57.7 | SMCJ16(C)AHM3/I, SMCJ16(C)AHV6G |
| SMCJ17(C)AQ | 17.0 | 18.90 | 20.9 | 5.0 | 27.6 | 53.3 | SMCJ17(C)AHM3/I, SMCJ17(C)AHV6G, TPSMC20(C)A |
| SMCJ18(C)AQ | 18.0 | 20.00 | 22.1 | 5.0 | 29.2 | 51.4 | SMCJ18(C)AHM3/I, SMCJ18(C)AHV6G |
| SMCJ20(C)AQ | 20.0 | 22.20 | 24.5 | 5.0 | 32.4 | 46.3 | SMCJ20(C)AHM3/I, SMCJ20(C)AHV6G |
| SMCJ22(C)AQ | 22.0 | 24.40 | 27.0 | 5.0 | 35.5 | 42.2 | SMCJ22(C)AHM3/I, SMCJ22(C)AHV6G |
| SMCJ24(C)AQ | 24.0 | 26.70 | 29.5 | 5.0 | 38.9 | 38.6 | SMCJ24(C)AHM3/I, SMCJ24(C)AHV6G |
| SMCJ26(C)AQ | 26.0 | 28.90 | 31.9 | 5.0 | 42.1 | 35.6 | SMCJ26(C)AHM3/I, SMCJ26(C)AHV6G |
| SMCJ28(C)AQ | 28.0 | 31.10 | 34.4 | 5.0 | 45.4 | 33.0 | SMCJ28(C)AHM3/I, SMCJ28(C)AHV6G |
| SMCJ30(C)AQ | 30.0 | 33.30 | 36.8 | 5.0 | 48.4 | 31.0 | SMCJ30(C)AHM3/I, SMCJ30(C)AHV6G |
| SMCJ33(C)AQ | 33.0 | 36.70 | 40.6 | 5.0 | 53.3 | 28.1 | SMCJ33(C)AHM3/I, SMCJ33(C)AHV6G |
| SMCJ36(C)AQ | 36.0 | 40.00 | 44.2 | 5.0 | 58.1 | 25.8 | SMCJ36(C)AHM3/I, SMCJ36(C)AHV6G |
| 3.0SMCJ14AQ | 14.0 | 15.60 | 17.2 | 5.0 | 23.2 | 129.3 | TPSMD14A, SMDJ14A |
| 3.0SMCJ20AQ | 20.0 | 22.20 | 24.5 | 5.0 | 32.4 | 92.6 | TPSMD20A, SM30T23AY, SMDJ20A |
| 3.0SMCJ22AQ | 22.0 | 24.40 | 27.0 | 5.0 | 35.5 | 84.5 | TPSMD22A, SM30T26AY, SMDJ22A |
| 3.0SMCJ24AQ | 24.0 | 26.70 | 29.5 | 5.0 | 38.9 | 77.1 | TPSMD24A, SM30T28AY, SMDJ24A |
| 3.0SMCJ28AQ | 28.0 | 31.10 | 34.4 | 5.0 | 45.4 | 66.1 | TPSMD28A, SM30T33AY, SMDJ28A |
| 3.0SMCJ30AQ | 30.0 | 33.30 | 36.8 | 5.0 | 48.4 | 62.0 | TPSMD30A, SM30T35AY, SMDJ30A |