

EC centrifugal fans - RadiCal

Edition 2018-05

ebmpapst

The engineer's choice



EC centrifugal fans - RadiCal

RadiCal impellers are made of high-tech composite material. Optimized flow control combined with high-efficiency GreenTech EC motors – not only for ventilation and air conditioning.

Those are the main features of the backward-curved centrifugal fans in the RadiCal series. The small RadiCal fans installed in an aerodynamically optimized 3D scroll housing are the latest addition.

This enhancement includes increased efficiency and added functionality such as measurement of air flow, air temperature or humidity.

So that this data can also be used, there is an optional serial MODBUS-RTU interface.

The impellers for the sizes from 133 to 560 mm are made of special composite material. This enables high rotational velocity and high power density for the fan.

The shape of the impellers was refined with complex simulation models in combination with measurements made on prototypes. The result is optimized low-loss flow through the impeller; there are no cross-section changes to cause losses in the impeller.

A uniform flow profile without laminar separation results in fewer sources of noise and better acoustics.

Changes and additions worth mentioning in this catalog are:

RadiCal with M3G150 Gen III:

In addition to the previous versions, sizes 500 and 560 are now available with the new EC motors in size M3G150 Gen III.

“In addition” because the motors in combination with the known impellers deliver significantly increased air performance.

To illustrate the air performance benefits compared with the previous fans, their characteristic curves are shown in curve families for each size.

Active PFC with RadiCal:

Sizes 500 and 560 are now available with the new three-phase 3 kW motor with integrated active PFC.

With these products, we can now fulfill the increasingly frequent requests for total harmonic distortion of no more than 5%.

Their characteristic curves are shown with those of the standard fans in a curve family.

That makes it easy to find comparable types.

Small RadiCals with more of what you need:

A new addition to the catalog is size 175, with various motor/impeller combinations.

Also new are RadiCals in sizes from 175 to 250 in a version with MODBUS-RTU and a basic PWM version.

Sizes 190 and 225 are the first innovative RadiCals in a scroll housing. The various designs from basic control to smart and autonomous open up whole new possibilities.

The new RadiPacs stand out with the following features:

- Best overall efficiency
- Comfortable noise level
- Compact design
- Fast availability
- Easy startup with uncomplicated configuration of control electronics
- Finely tuned system with pre-configured motor / control electronics / impeller unit
- Plug & play: fully pre-assembled unit ready to install
- Single source: one contact for everything
- Logistic advantages due to complete unit
- Complete product line without gaps
- No magnets with rare earths

Subject to technical changes.

Contents

| | | | |
|---|----|--------------------------------------|-----|
| EC centrifugal fans - RadiCal | 2 | Technology: | |
| About ebm-papst | 4 | - Tender specifications | 130 |
| Product- & characteristic curves overview | 6 | - Accessories | 132 |
| EC centrifugal fans RadiCal Ø 133-250 (Compact) | 10 | - Connection diagrams | 142 |
| EC centrifugal fans RadiCal Ø 250-560 | 76 | - FanScout product selection program | 160 |
| | | - Technical parameters & scope | 162 |
| | | ebm-papst agents | 166 |



About ebm-papst

As technological leader for ventilation and drive engineering, ebm-papst is in demand as an engineering partner in many industries. With over 15,000 different products, we provide the right solution for just about any challenge. Our fans and drives are reliable, quiet and energy-efficient.

Six reasons that make us the ideal partner:

Our systems expertise.

You want the best solution for every project. The interrelationships between ventilation and drive engineering must thus be considered as a whole. And that's what we do – with **motor technology** that sets standards, sophisticated **electronics** and **aerodynamic designs** – all from a single source and perfectly matched. These system solutions release unique synergies worldwide. And in particular – they relieve you of a lot of work, so that you can concentrate on your core competency.

The ebm-papst spirit of invention.

In addition to our wide range of products, we are always able to develop customized solutions for you. A diversified team of 600 engineers and technicians works at our three locations in Germany: Mulfingen, Landshut and St. Georgen. Contact us to discuss your next project.

Our lead in technology.

As pioneer and trail-blazer for developing highly efficient EC technology, we are way ahead of other motor manufacturers. Almost all our products are also available with GreenTech EC technology. The list of benefits is long: higher efficiency, maintenance-free, longer service life, sound reduction, intelligent control characteristics and unrivalled energy efficiency with savings of up to 80% compared to conventional AC technology. Let our technology be your competitive advantage as you lead in your industry.

Closeness to our customers.

ebm-papst has 25 production locations worldwide (including facilities in Germany, China and the USA), together with 49 sales offices, each of which has a dense network of sales representatives. You will always have a local contact, someone who speaks your language and knows your market.

Our standard of quality.

Of course you can rely on the highest standards of quality with our products. Our quality management is uncompromising, at every step in every process. This is underscored by our certification according to international standards including DIN EN ISO 9001, TS declaration of conformity and DIN EN ISO 14001.

Our sustainable approach.

Assuming responsibility for the environment, for our employees and for society is an integral part of our corporate philosophy. We develop products with an eye to maximum environmental compatibility, in particular resource-preserving production methods. We promote environmental awareness among our young staff and are actively involved in sports, culture and education. That's what makes us a leading company – and an ideal partner for you.



The story of our success to market and technology pioneer.

- 1963** Founding of **Elektrobau Mulfingen GmbH & Co. KG** by Gerhard Sturm and Heinz Ziehl.
- 1965** First tubeaxial fan developed in EC/DC technology.
- 1966** ebm's success takes off with the new 68 motor.
- 1972** The first ebm foreign subsidiary is established in Sweden.
- 1988** Gerhard Sturm is awarded the Federal Cross of Merit.
- 1990** The sixty-millionth external-rotor fan is produced.
- 1992** Acquisition of **PAPST Motoren GmbH** in St. Georgen.
- 1997** Buyout of the **Landshut (mvl)** plant.
- 1998** Development of first fans with integrated electronics.
- 2003** Change of name to **ebm-papst**.
- 2008** The **HyBlade®** range of fans sets new efficiency standards.
- 2010** **GreenTech** – our sign for energy efficiency and resource preservation.
- 2011** **RadiCal** defines a new standard for EC centrifugal fans.
- 2013** ebm-papst takes over the gearbox specialist Zeitlauf and wins the **German Sustainability Award**.
- 2014** Team partnership with Mercedes AMG PETRONAS Formula 1 team.
- 2015** **RadiPac** pushes the limits of efficiency.
- 2016** **AxiBlade** sets new standards in ventilation, refrigeration and air-conditioning.



Product overview – EC-RadiCal



Ø 133 - Ø 250 (Compact)

| Ø | Motor | Nominal voltage range VAC | Max. Input power W | Centrifugal fan  | Centrifugal module with support basket  | Technical features Speed regulation | Page ff. |
|-----|------------|---------------------------|--------------------|---|--|--|----------|
| 133 | M3G 045-AI | 1~200-240 | 27 | R3G 133-RA01 -03 | K3G 133-RA01 -03 | 0-10 V / PWM | 12 |
| | M3G 055-BI | 1~200-240 | 85 | R3G 175-RC05 -01 | K3G 175-RC05 -01 | 2 Speed stages | |
| | M3G 055-CF | 1~200-240 | 166 | R3G 175-RD53 -01 | K3G 175-RD53 -01 | 2 Speed stages | |
| | M3G 055-BI | 1~200-240 | 85 | R3G 175-RC05 -03 | K3G 175-RC05 -03 | 0-10 V / PWM | |
| | M3G 055-BI | 1~200-240 | 85 | R3G 175-RC05 -07 | K3G 175-RC05 -07 | PWM | |
| | M3G 055-CF | 1~200-240 | 115 | R3G 175-RG19 -05 | K3G 175-RG19 -05 | 0-10 V / PWM | |
| | M3G 055-CF | 1~200-240 | 115 | R3G 175-RG19 -09 | K3G 175-RG19 -09 | PWM | |
| | M3G 055-CF | 1~200-240 | 166 | R3G 175-RD53 -03 | K3G 175-RD53 -03 | 0-10 V / PWM | |
| | M3G 055-CF | 1~200-240 | 166 | R3G 175-RD53 -07 | K3G 175-RD53 -07 | PWM | |
| 175 | M3G 055-CF | 1~200-240 | 166 | R3G 175-RD53 -08 | K3G 175-RD53 -08 | MODBUS-RTU | 16 |
| | M3G 055-BD | 1~200-240 | 57 | R3G 190-RB01 -01 | K3G 190-RB01 -01 | 2 Speed stages | |
| | M3G 055-CF | 1~200-240 | 169 | R3G 190-RD45 -01 | K3G 190-RD45 -01 | 2 Speed stages | |
| | M3G 055-BI | 1~200-240 | 83 | R3G 190-RC05 -03 | K3G 190-RC05 -03 | 0-10 V / PWM | |
| | M3G 055-BI | 1~200-240 | 83 | R3G 190-RC05 -05 | K3G 190-RC05 -05 | PWM | |
| | M3G 055-CF | 1~200-240 | 115 | R3G 190-RG19 -01 | K3G 190-RG19 -01 | 0-10 V / PWM | |
| | M3G 055-CF | 1~200-240 | 115 | R3G 190-RG19 -05 | K3G 190-RG19 -05 | PWM | |
| | M3G 055-CF | 1~200-240 | 169 | R3G 190-RD45 -03 | K3G 190-RD45 -03 | 0-10 V / PWM | |
| | M3G 055-CF | 1~200-240 | 169 | R3G 190-RD45 -05 | K3G 190-RD45 -05 | PWM | |
| 190 | M3G 055-CF | 1~200-240 | 169 | R3G 190-RD45 -08 | K3G 190-RD45 -08 | MODBUS-RTU | 24 |
| | M3G 055-BI | 1~200-240 | 85 | R3G 220-RC05 -01 | K3G 220-RC05 -01 | 2 Speed stages | |
| | M3G 055-CF | 1~200-240 | 168 | R3G 220-RD53 -01 | K3G 220-RD53 -01 | 2 Speed stages | |
| | M3G 055-BI | 1~200-240 | 85 | R3G 220-RC05 -03 | K3G 220-RC05 -03 | 0-10 V / PWM | |
| | M3G 055-BI | 1~200-240 | 85 | R3G 220-RC05 -05 | K3G 220-RC05 -05 | PWM | |
| | M3G 055-CF | 1~200-240 | 115 | R3G 220-RG19 -01 | K3G 220-RG19 -01 | 0-10 V / PWM | |
| | M3G 055-CF | 1~200-240 | 115 | R3G 220-RG19 -05 | K3G 220-RG19 -05 | PWM | |
| | M3G 055-CF | 1~200-240 | 168 | R3G 220-RD53 -03 | K3G 220-RD53 -03 | 0-10 V / PWM | |
| | M3G 055-CF | 1~200-240 | 168 | R3G 220-RD53 -05 | K3G 220-RD53 -05 | PWM | |
| 220 | M3G 055-CF | 1~200-240 | 168 | R3G 220-RD53 -08 | K3G 220-RD53 -08 | MODBUS-RTU | 38 |
| | M3G 055-CF | 1~200-240 | 82 | R3G 225-RD05 -01 | K3G 255-RD05 -01 | 2 Speed stages | |
| | M3G 055-DF | 1~200-240 | 170 | R3G 225-RE07 -01 | K3G 255-RE07 -01 | 2 Speed stages | |
| | M3G 055-CF | 1~200-240 | 82 | R3G 225-RD05 -03 | K3G 255-RD05 -03 | 0-10 V / PWM | |
| | M3G 055-CF | 1~200-240 | 82 | R3G 225-RD05 -05 | K3G 255-RD05 -05 | PWM | |
| | M3G 055-CF | 1~200-240 | 107 | R3G 225-RH19 -01 | K3G 255-RH19 -01 | 0-10 V / PWM | |
| | M3G 055-CF | 1~200-240 | 107 | R3G 225-RH19 -05 | K3G 255-RH19 -05 | PWM | |
| | M3G 055-DF | 1~200-240 | 170 | R3G 225-RE07 -03 | K3G 255-RE07 -03 | 0-10 V / PWM | |
| | M3G 055-DF | 1~200-240 | 170 | R3G 225-RE07 -05 | K3G 255-RE07 -05 | PWM | |
| 225 | M3G 055-DF | 1~200-240 | 170 | R3G 225-RE07 -22 | K3G 255-RE07 -22 | MODBUS-RTU | 46 |

Subject to technical changes.

Product overview – EC-RadiCal



Ø 133 - Ø 250 (Compact)

| Ø | Motor | Nominal voltage range VAC | Max. Input power W | Centrifugal fan  | Centrifugal module with support basket  | Technical features Speed regulation | Page ff. |
|-----|------------|---------------------------|--------------------|--|--|--|----------|
| 250 | M3G 055-CF | 1~200-240 | 80 | R3G 250-RD17 -01 | K3G 250-RD17 -01 | 2 Speed stages | 60 |
| | M3G 055-DF | 1~200-240 | 170 | R3G 250-RE07 -05 | K3G 250-RE07 -05 | 2 Speed stages | |
| | M3G 055-CF | 1~200-240 | 80 | R3G 250-RD17 -03 | K3G 250-RD17 -03 | 0-10 V / PWM | |
| | M3G 055-CF | 1~200-240 | 80 | R3G 250-RD17 -05 | K3G 250-RD17 -05 | PWM | |
| | M3G 055-DF | 1~200-240 | 115 | R3G 250-RH13 -01 | K3G 250-RH13 -01 | 0-10 V / PWM | |
| | M3G 055-DF | 1~200-240 | 115 | R3G 250-RH13 -05 | K3G 250-RH13 -05 | PWM | |
| | M3G 055-DF | 1~200-240 | 170 | R3G 250-RE07 -07 | K3G 250-RE07 -07 | 0-10 V / PWM | |
| | M3G 055-DF | 1~200-240 | 170 | R3G 250-RE07 -21 | K3G 250-RE07 -21 | PWM | |
| | M3G 055-DF | 1~200-240 | 170 | R3G 250-RE07 -22 | K3G 250-RE07 -22 | MODBUS-RTU | |
| 175 | M1G 055-CF | 1~200-240 | 100 | R1G 175-RF04 -01 | K1G 175-RF04 -01 | PWM | 68 |
| 190 | M1G 055-CF | 1~200-240 | 100 | R1G 190-RF04 -01 | K1G 190-RF04 -01 | PWM | |
| 220 | M1G 055-CF | 1~200-240 | 100 | R1G 220-RF01 -01 | K1G 220-RF01 -01 | PWM | |
| 225 | M1G 055-DF | 1~200-240 | 100 | R1G 225-RG04 -01 | K1G 225-RG04 -01 | PWM | |
| 250 | M1G 055-DF | 1~200-240 | 100 | R1G 250-RG01 -01 | K1G 250-RG01 -01 | PWM | |
| Ø | Motor | Nominal voltage range VAC | Max. Input power W | Centrifugal fan with housing  | Technical features Speed regulation Sensor regulation ⁽¹⁾ | Page ff. | |
| 190 | M3G 055-BI | 1~200-240 | 72 | G3G 190-RP03 -04 | MODBUS-RTU ⁽¹⁾ | 32 | |
| | M3G 055-BI | 1~200-240 | 83 | G3G 190-RC05 -02 | 0-10 V / PWM | | |
| | M3G 055-BI | 1~200-240 | 83 | G3G 190-RC05 -05 | PWM | | |
| | M3G 055-CF | 1~200-240 | 115 | G3G 190-RG19 -01 | 0-10 V / PWM | | |
| | M3G 055-CF | 1~200-240 | 115 | G3G 190-RG19 -05 | PWM | | |
| | M3G 055-CF | 1~200-240 | 170 | G3G 190-RD45 -03 | 0-10 V / PWM | | |
| | M3G 055-CF | 1~200-240 | 170 | G3G 190-RD45 -05 | PWM | | |
| | M3G 055-CF | 1~200-240 | 170 | G3G 190-RD45 -08 | MODBUS-RTU | | |
| | M3G 055-CF | 1~200-240 | 170 | G3G 190-RQ45 -04 | MODBUS-RTU ⁽¹⁾ | | |
| 225 | M3G 055-CF | 1~200-240 | 85 | G3G 225-RD05 -02 | 0-10 V / PWM | 54 | |
| | M3G 055-CF | 1~200-240 | 85 | G3G 225-RD05 -05 | PWM | | |
| | M3G 055-CF | 1~200-240 | 105 | G3G 225-RH19 -01 | 0-10 V / PWM | | |
| | M3G 055-CF | 1~200-240 | 105 | G3G 225-RH19 -05 | PWM | | |
| | M3G 055-DF | 1~200-240 | 165 | G3G 225-RE07 -03 | 0-10 V / PWM | | |
| | M3G 055-DF | 1~200-240 | 165 | G3G 225-RE07 -05 | PWM | | |
| | M3G 055-DF | 1~200-240 | 165 | G3G 225-RE07 -22 | MODBUS-RTU | | |
| | M3G 055-DF | 1~200-240 | 165 | G3G 225-RR07 -04 | MODBUS-RTU ⁽¹⁾ | | |

Subject to technical changes.

Product overview – EC-RadiCal

Ø 250 - Ø 560

| Ø | Motor | Nominal voltage range VAC | Max. Input power W | Centrifugal fan  | Centrifugal module with support bracket  | Page ff. |
|-----|------------|---------------------------|--------------------|---|---|----------|
| 250 | M3G 084-DF | 1~200-277 | 500 | R3G 250-RR01 -H1 | K3G 250-RR01 -H2 | 76 |
| | M3G 084-DF | 1~200-277 | 750 | R3G 250-RR02 -I1 | K3G 250-RR02 -I2 | |
| 280 | M3G 074-CF | 1~200-240 | 168 | R3G 280-RB02 -03 | K3G 280-RB02 -03 | 80 |
| | M3G 084-DF | 1~200-277 | 500 | R3G 280-RR03 -H1 | K3G 280-RR03 -H2 | |
| | M3G 084-DF | 1~200-277 | 660 | R3G 280-RR04 -I1 | K3G 280-RR04 -I2 | |
| 310 | M3G 074-CF | 1~200-240 | 150 | R3G 310-RB01 -03 | K3G 310-RB01 -03 | 86 |
| | M3G 084-DF | 1~200-277 | 500 | R3G 310-RR05 -H1 | K3G 310-RR05 -H2 | |
| | M3G 084-FA | 1~200-277 | 730 | R3G 310-RS01 -I1 | K3G 310-RS01 -I2 | |
| | M3G 084-FA | 3~380-480 | 790 | R3G 310-RS05 -J1 | K3G 310-RS05 -J2 | |
| 355 | M3G 074-DF | 1~200-240 | 168 | R3G 355-RB03 -03 | K3G 355-RB03 -03 | 92 |
| | M3G 084-DF | 1~200-277 | 250 | R3G 355-RR06 -G1 | K3G 355-RR06 -G2 | |
| | M3G 084-FA | 1~200-277 | 500 | R3G 355-RS02 -H1 | K3G 355-RS02 -H2 | |
| | M3G 084-GF | 1~200-277 | 750 | R3G 355-RT01 -I1 | K3G 355-RT01 -I2 | |
| | M3G 084-EA | 3~380-480 | 1100 | R3G 355-RJ75 -01 | K3G 355-RJ75 -01 | |
| 400 | M3G 084-DF | 1~200-277 | 1170 | R3G 400-RR07 -G1 | K3G 400-RR07 -G2 | 100 |
| | M3G 084-FA | 1~200-277 | 1500 | R3G 400-RS03 -H1 | K3G 400-RS03 -H2 | |
| | M3G 084-GF | 1~200-277 | 1700 | R3G 400-RT02 -I1 | K3G 400-RT02 -I2 | |
| | M3G 112-EA | 3~380-480 | 2060 | R3G 400-RJ75 -01 | K3G 400-RJ75 -01 | |
| 450 | M3G 084-FA | 1~200-277 | 1000 | R3G 450-RS04 -G1 | K3G 450-RS04 -G2 | 106 |
| | M3G 084-GF | 1~200-277 | 1260 | R3G 450-RT03 -H1 | K3G 450-RT03 -H2 | |
| | M3G 112-EA | 1~200-277 | 1440 | R3G 450-RJ74 -21 | K3G 450-RJ74 -21 | |
| | M3G 112-GA | 3~380-480 | 1550 | R3G 450-RK56 -01 | K3G 450-RK56 -01 | |
| 500 | M3G 084-FA | 1~200-277 | 250 | R3G 500-RS06 -G1 | K3G 500-RS06 -G2 | 112 |
| | M3G 084-GF | 1~200-277 | 460 | R3G 500-RT04 -H1 | K3G 500-RT04 -H2 | |
| | M3G 112-GA | 1~200-277 | 750 | R3G500-RK55 -21 | K3G500-RK55 -21 | |
| | M3G 112-IA | 3~380-480 | 1320 | R3G 500-RL96 -01 | K3G 500-RL96 -01 | |
| | M3G 150-FF | 3~380-480 | 2600 | R3G 500-RA24 -71 | K3G 500-RA24 -71 | |
| | M3G 150-FF | 3~380-480 | 3190 | R3G 500-RA26 -C1* | K3G 500-RA26 -C1* | |
| | M3G 150-FF | 3~380-480 | 3650 | R3G 500-RA28 -03 | K3G 500-RA28 -03 | |
| 560 | M3G 150-FF | 1~200-277 | 1500 | R3G 560-RA25 -21 | K3G 560-RA25 -21 | 122 |
| | M3G 150-FF | 3~380-480 | 2360 | R3G 560-RA25 -71 | K3G 560-RA25 -71 | |
| | M3G 150-IF | 3~380-480 | 2900 | R3G 560-RB31 -71 | K3G 560-RB31 -71 | |
| | M3G 150-IF | 3~380-480 | 3190 | R3G 560-RB27 -C1* | K3G 560-RB27 -C1* | |
| | M3G 150-FF | 3~380-480 | 3700 | R3G 560-RA24 -03 | K3G 560-RA24 -03 | |

* with active-PFC

* with active-PFC

Subject to technical changes.

Characteristic curves overview – EC-RadiCal

Ø 133 - Ø 560

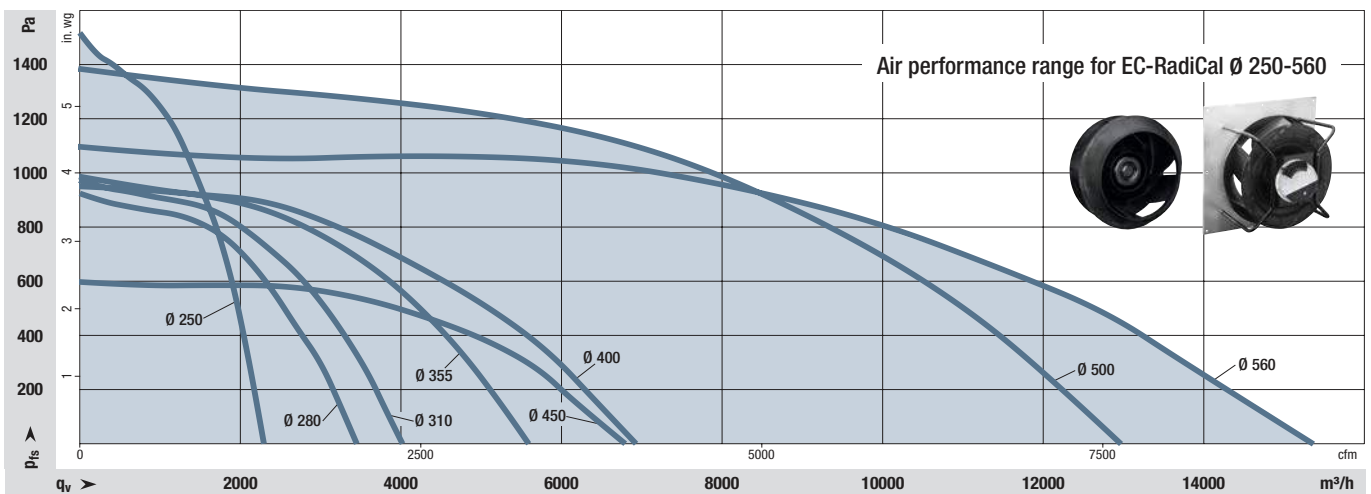
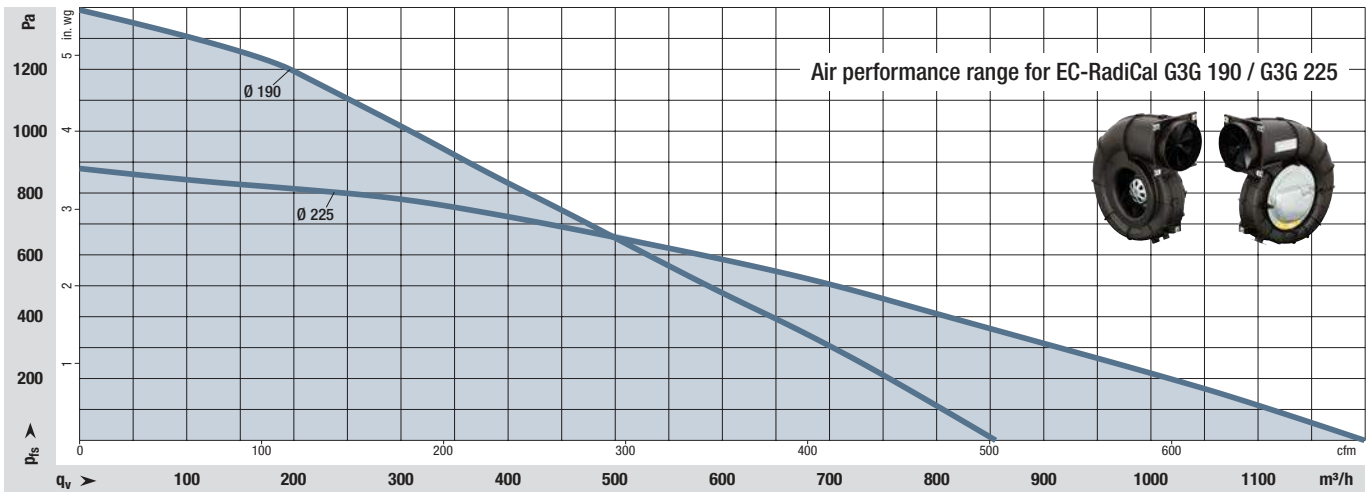
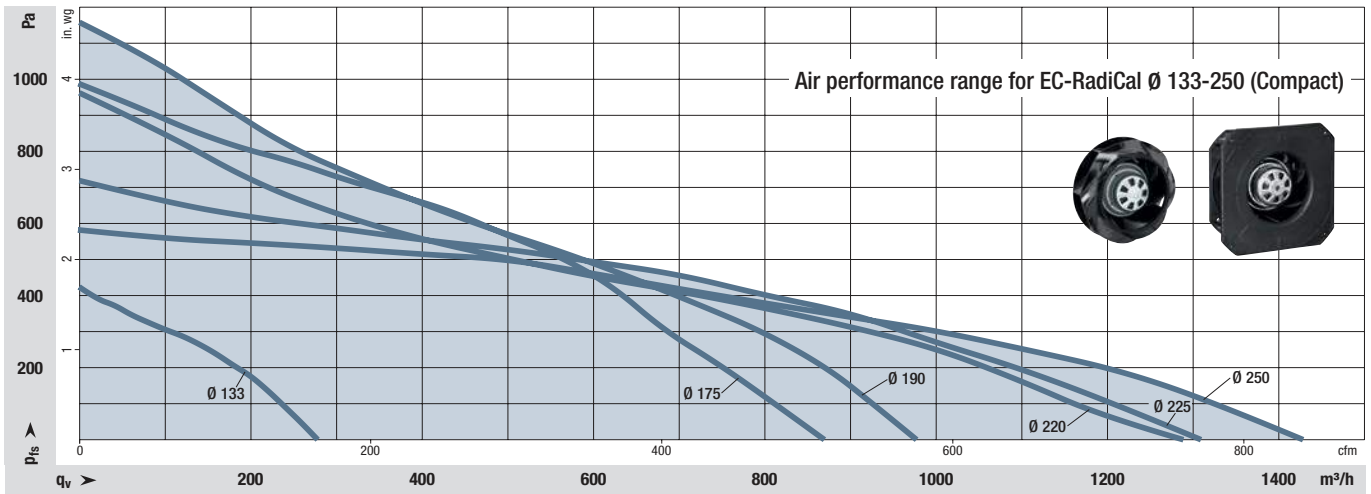

The graphics shows the maximum air performance for each size. If less performance is required, variants with smaller motors can be used. This saves additional costs. The right fan for every application!

Subject to technical changes.

EC centrifugal fans – RadiCal

Ø 133 - 560



EC centrifugal fans – RadiCal

backward curved, Ø 133

- **Material:** Housing: Plastic
Impeller: Plastic
Rotor: Thick-film passivated
Electronics housing: Die-cast aluminium
- **Number of blades:** 7
- **Direction of rotation:** Clockwise viewed toward rotor
- **Degree of protection:** IP 54
- **Insulation class:** "B"
- **Installation position:** Any
- **Condensation drainage holes:** None, open rotor
- **Mode:** Continuous operation (S1)
- **Mounting:** Maintenance-free ball bearings



Nominal data

| Type | Motor | Curve | Nominal voltage range | Frequency | Speed ⁽¹⁾ | Max. Input power ⁽¹⁾ | Max. Input current ⁽¹⁾ | Perm. ambient temp. | Techn. features and connection diagram |
|---------|------------|-------------|-----------------------|-----------|----------------------|---------------------------------|-----------------------------------|---------------------|--|
| | | VAC | Hz | rpm | W | A | °C | | |
| *3G 133 | M3G 045-AI | Ⓐ 1~200-240 | 50/60 | 3770 | 27 | 0,27 | -25..+60 | P. 146 / RC3) | |

Subject to change

(1) Nominal data at operating point with maximum load and 230 VAC.

Curves: Speed-controlled 0-10 V / PWM

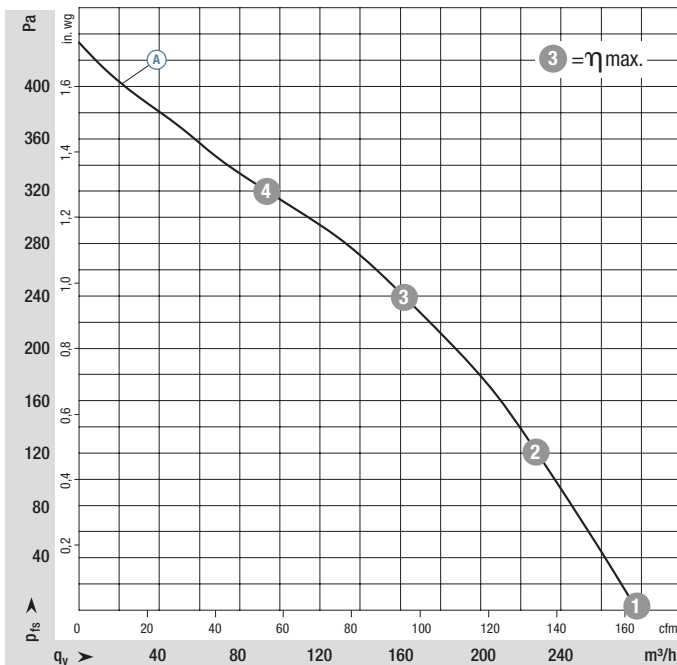

| | n rpm | P _{ed} W | I A | L _{wA} dB(A) |
|-----|-------|-------------------|------|-----------------------|
| Ⓐ 1 | 3930 | 24 | 0,23 | 66 |
| Ⓐ 2 | 3800 | 26 | 0,26 | 63 |
| Ⓐ 3 | 3770 | 27 | 0,27 | 61 |
| Ⓐ 4 | 3850 | 25 | 0,25 | 66 |

Air performance measured according to: ISO 5801, installation category A, with ebm-papst inlet ring without contact protection. Intake-side sound level: L_{wA} according to ISO 13347, L_{pA} measured at 1 m distance from fan axis. The values given are only applicable under the specified measuring conditions and may differ depending on the installation conditions. In the event of deviation from the standard configuration, the parameters must be checked in installed condition. See Page 162 ff. for detailed information.

- **Technical features:** See connection diagram P. 146
- **EMC:** Interference emission according to EN 61000-6-3
Immunity to interference according to EN 61000-6-2
Circuit feedback according to EN 61000-3-2/3
- **Touch current:** < 3,5 mA according to IEC 60990 (measuring circuit Fig. 4)
- **Cable exit:** Variable
- **Protection class:** I (with customer connection of protective earth)
- **Conformity with standards:** EN 60335-1, CE
- **Approvals:** VDE, UL, CSA, CCC, EAC are applied for
- **Efficiency:** Ecodesign EU regulation EU 327/2011



Weight
Centrifugal fan



Weight
Centrifugal module
w. support basket

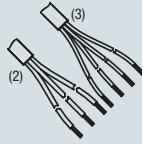

Cables

| Centrifugal fan | kg | Centrifugal module w. support basket | kg | Speed-controlled 0-10 V / PWM |
|------------------|------|---|------|----------------------------------|
| R3G 133-RA01 -03 | 0,50 | K3G 133-RA01 -03 | 0,75 | X |

(2) PVC AWG 20, 3x splices
(3) PVC AWG 22, 4x splices

EC centrifugal fans – RadiCal

backward curved, Ø 133, Speed-controlled



R3G 133-RA01-03 (Centrifugal fan)

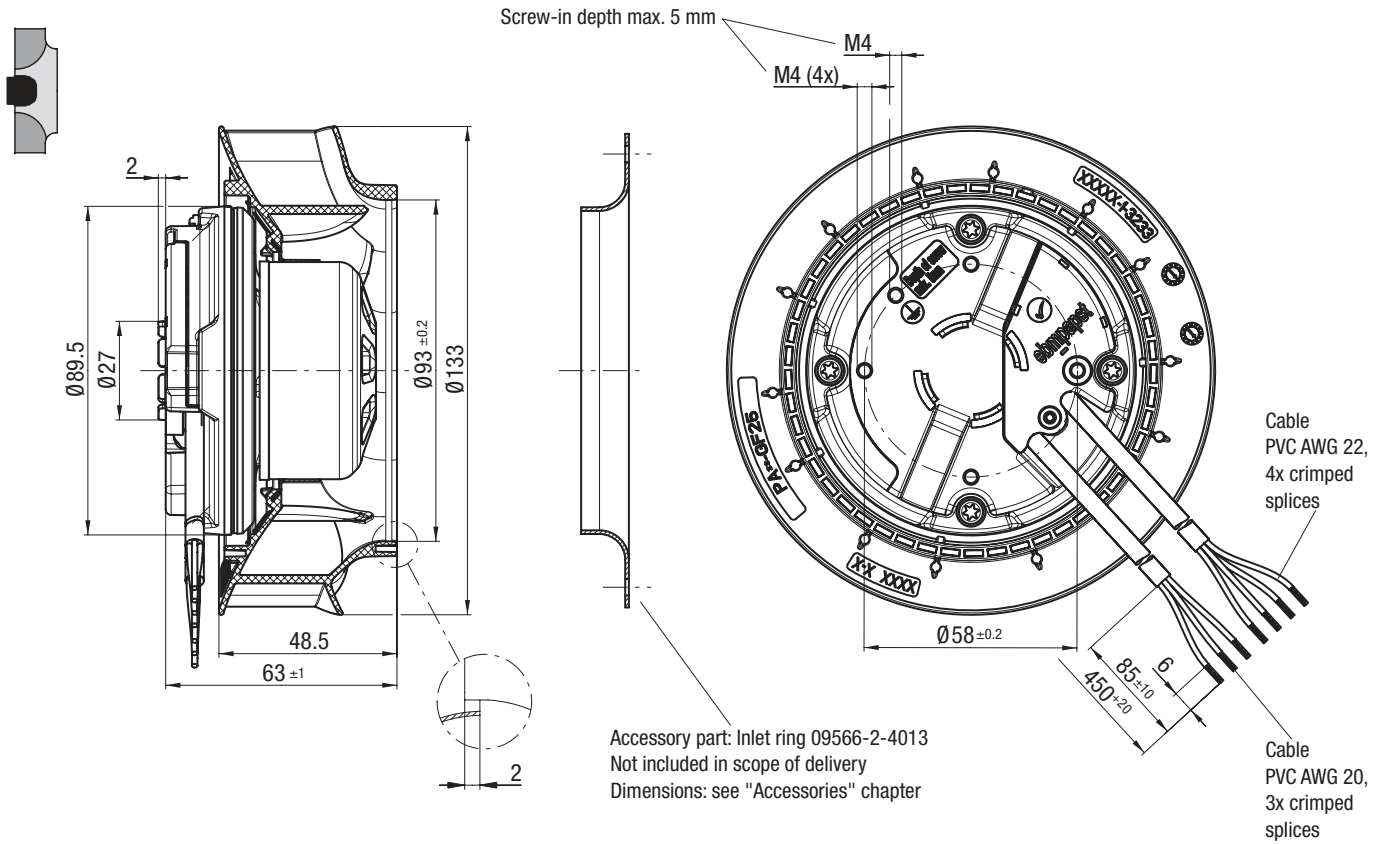

K3G 133-RA01-03 (Centrifugal module with support basket)

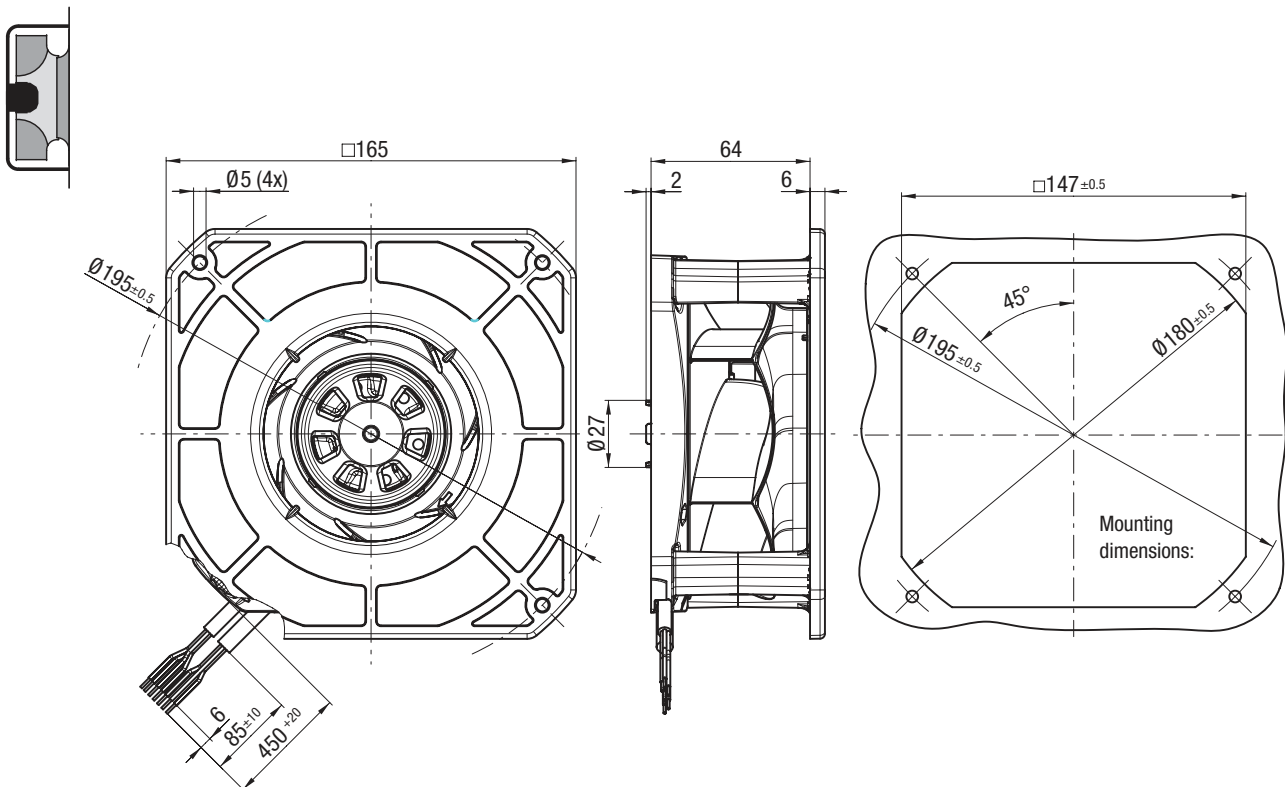

EC centrifugal fans – RadiCal

backward curved, Ø 175



- **Material:** Housing: Plastic
Impeller: Plastic
Rotor: Thick-film passivated
Electronics housing: Die-cast aluminium
- **Number of blades:** 7
- **Direction of rotation:** Clockwise viewed toward rotor
- **Degree of protection:** IP 54
- **Insulation class:** "B"
- **Installation position:** Any
- **Condensation drainage holes:** None, open rotor
- **Mode:** Continuous operation (S1)
- **Mounting:** Maintenance-free ball bearings

Nominal data

| Type | Motor | Curve | Nominal voltage range | Frequency | Speed ⁽¹⁾ | Max. Input power ⁽¹⁾ | Max. Input current ⁽¹⁾ | Perm. ambient temp. | Techn. features and connection diagram |
|---------|------------|-------|-----------------------|-----------|----------------------|---------------------------------|-----------------------------------|---------------------|--|
| Type | Motor | VAC | Hz | rpm | W | A | °C | | |
| *3G 175 | M3G 055-BI | Ⓐ | 1~200-240 | 50/60 | 3740 | 85 | 0,80 | -25..+60 | P. 145 / RC2) |
| *3G 175 | M3G 055-CF | Ⓑ | 1~200-240 | 50/60 | 4720 | 166 | 1,40 | -25..+60 | P. 145 / RC2) |
| *3G 175 | M3G 055-BI | Ⓒ | 1~200-240 | 50/60 | 3740 | 85 | 0,80 | -25..+60 | P. 146 / RC3) |
| *3G 175 | M3G 055-BI | Ⓓ | 1~200-240 | 50/60 | 3740 | 85 | 0,80 | -25..+60 | P. 154 / RC10) |
| *3G 175 | M3G 055-CF | Ⓔ | 1~200-240 | 50/60 | 4200 | 115 | 1,00 | -25..+60 | P. 144 / RC1) |
| *3G 175 | M3G 055-CF | Ⓕ | 1~200-240 | 50/60 | 4200 | 115 | 1,00 | -25..+60 | P. 154 / RC10) |
| *3G 175 | M3G 055-CF | Ⓖ | 1~200-240 | 50/60 | 4720 | 166 | 1,40 | -25..+60 | P. 152 / RC8) |
| *3G 175 | M3G 055-CF | Ⓗ | 1~200-240 | 50/60 | 4720 | 166 | 1,40 | -25..+60 | P. 154 / RC10) |
| *3G 175 | M3G 055-CF | Ⓘ | 1~200-240 | 50/60 | 4720 | 166 | 1,40 | -25..+60 | P. 155 / RC11) |

Subject to change

(1) Nominal data at operating point with maximum load and 230 VAC.

Curves: 2 Speed stages

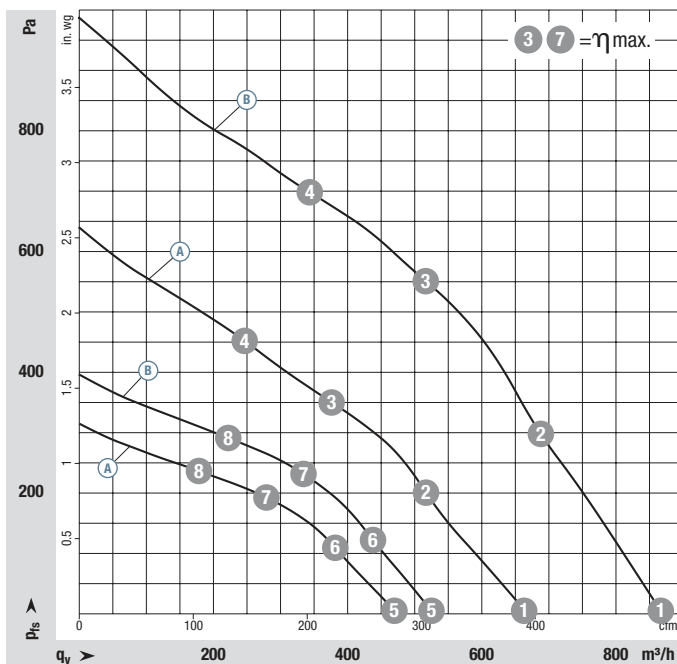

| | n rpm | P _{ed} W | I A | L _{wA} dB(A) |
|-----|-------|-------------------|------|-----------------------|
| Ⓐ ① | 3955 | 81 | 0,71 | 78 |
| Ⓐ ② | 3735 | 85 | 0,75 | 70 |
| Ⓐ ③ | 3700 | 85 | 0,75 | 68 |
| Ⓐ ④ | 3835 | 85 | 0,75 | 71 |
| Ⓐ ⑤ | 2810 | 33 | 0,33 | 70 |
| Ⓐ ⑥ | 2760 | 36 | 0,36 | 62 |
| Ⓐ ⑦ | 2750 | 36 | 0,37 | 59 |
| Ⓐ ⑧ | 2780 | 34 | 0,35 | 61 |
| Ⓑ ① | 4925 | 139 | 1,14 | 81 |
| Ⓑ ② | 4730 | 158 | 1,28 | 76 |
| Ⓑ ③ | 4700 | 165 | 1,35 | 75 |
| Ⓑ ④ | 4755 | 155 | 1,25 | 78 |
| Ⓑ ⑤ | 3130 | 43 | 0,38 | 69 |
| Ⓑ ⑥ | 3075 | 48 | 0,42 | 65 |
| Ⓑ ⑦ | 3070 | 49 | 0,43 | 64 |
| Ⓑ ⑧ | 3090 | 47 | 0,41 | 67 |

Air performance measured according to: ISO 5801, installation category A, with ebm-papst inlet ring without contact protection. Intake-side sound level: L_{wA} according to ISO 13347, L_{pA} measured at 1 m distance from fan axis. The values given are only applicable under the specified measuring conditions and may differ depending on the installation conditions. In the event of deviation from the standard configuration, the parameters must be checked in installed condition. See Page 162 ff. for detailed information.

- **Technical features:** See connection diagram P. 144 ff.
- **Touch current:** <= 3,5 mA according to IEC 60990 (measuring circuit Fig. 4)
- **Cable exit:** Variable
- **Protection class:** I (with customer connection of protective earth)
- **Conformity with standards:** CE
- **Approvals:** UL 1004-7 + 60730; C22.2 Nr.77 + CAN/CSA-E60730-1
- **Efficiency:** Ecodesign EU regulation EU 327/2011

| Centrifugal fan | kg | Centrifugal module w. support basket | kg | 2 Speed stages | Speed-controlled 0-10 V / PWM | Speed-controlled PWM | Speed-controlled MODBUS-RTU |
|------------------|------|--------------------------------------|------|----------------|-------------------------------|----------------------|-----------------------------|
| R3G 175-RC05 -01 | 1,10 | K3G 175-RC05 -01 | 1,40 | X | | | |
| R3G 175-RD53 -01 | 1,40 | K3G 175-RD53 -01 | 1,60 | X | | | |
| R3G 175-RC05 -03 | 1,10 | K3G 175-RC05 -03 | 1,40 | | X | | |
| R3G 175-RC05 -07 | 1,10 | K3G 175-RC05 -07 | 1,40 | | | X | |
| R3G 175-RG19 -05 | 1,40 | K3G 175-RG19 -05 | 1,60 | | X | | |
| R3G 175-RG19 -09 | 1,40 | K3G 175-RG19 -09 | 1,60 | | | X | |
| R3G 175-RD53 -03 | 1,40 | K3G 175-RD53 -03 | 1,50 | | X | | |
| R3G 175-RD53 -07 | 1,40 | K3G 175-RD53 -07 | 1,50 | | | X | |
| R3G 175-RD53 -08 | 1,40 | K3G 175-RD53 -08 | 1,50 | | | | X |

(2) PVC AWG 20, 4x splices (3) PVC AWG 20, 3x splices
(4) PVC AWG 22, 4x splices (5) PVC AWG 20, 3x splices
(6) PVC AWG 22, 3x splices (7) PVC AWG 20, 3x splices
(8) PVC AWG 22, 5x splices

Curves:
Speed-controlled
0-10 V / PWM
PWM
MODBUS-RTU

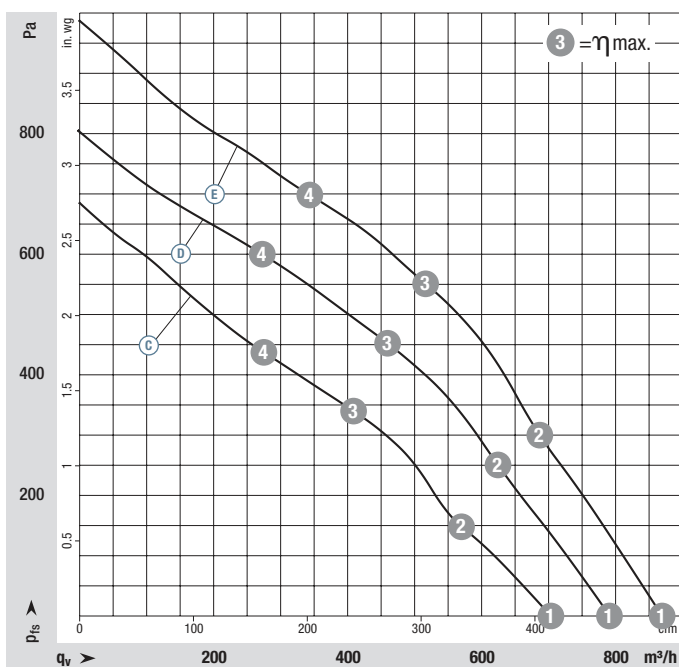

| | n rpm | P _{ed} W | I A | L _{wA} dB(A) |
|-----|-------|-------------------|------|-----------------------|
| ⓐ 1 | 4050 | 85 | 0,80 | 77 |
| ⓐ 2 | 3815 | 85 | 0,80 | 72 |
| ⓐ 3 | 3740 | 85 | 0,80 | 67 |
| ⓐ 4 | 3825 | 85 | 0,80 | 70 |
| ⓓ 1 | 4445 | 106 | 0,89 | 79 |
| ⓓ 2 | 4230 | 115 | 0,99 | 74 |
| ⓓ 3 | 4200 | 115 | 1,00 | 70 |
| ⓓ 4 | 4315 | 114 | 0,96 | 74 |
| ⓔ 1 | 4925 | 139 | 1,14 | 81 |
| ⓔ 2 | 4730 | 158 | 1,28 | 76 |
| ⓔ 3 | 4720 | 166 | 1,40 | 75 |
| ⓔ 4 | 4755 | 155 | 1,25 | 78 |

Air performance measured according to: ISO 5801, installation category A, with ebm-papst inlet ring without contact protection. Intake-side sound level: L_{wA} according to ISO 13347, L_{pA} measured at 1 m distance from fan axis. The values given are only applicable under the specified measuring conditions and may differ depending on the installation conditions. In the event of deviation from the standard configuration, the parameters must be checked in installed condition. See Page 162 ff. for detailed information.

EC centrifugal fans – RadiCal

backward curved, Ø 175, 2 Speed stages, 85 W - Electronics



R3G 175-RC05-01 (Centrifugal fan)

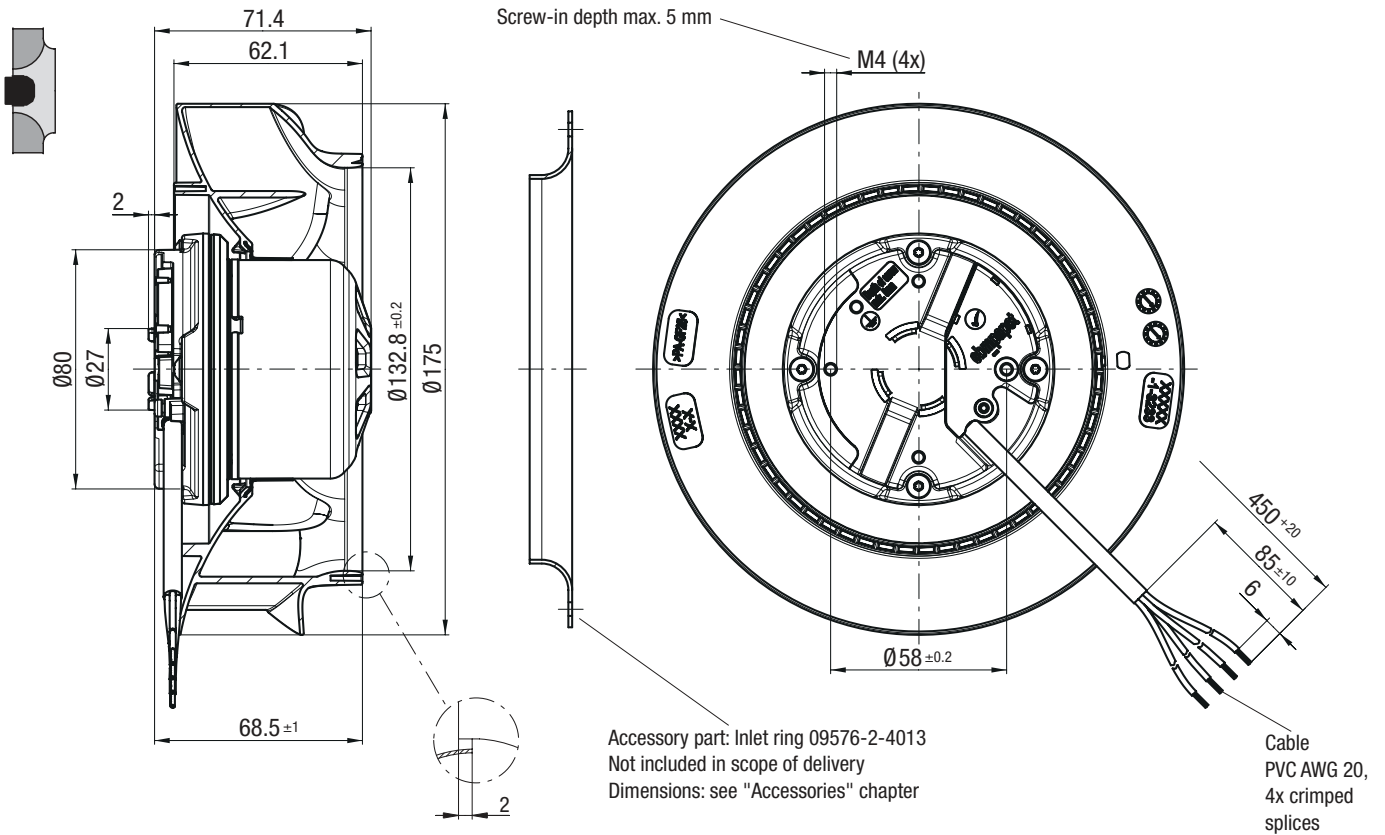

K3G 175-RC05-01 (Centrifugal module with support basket)

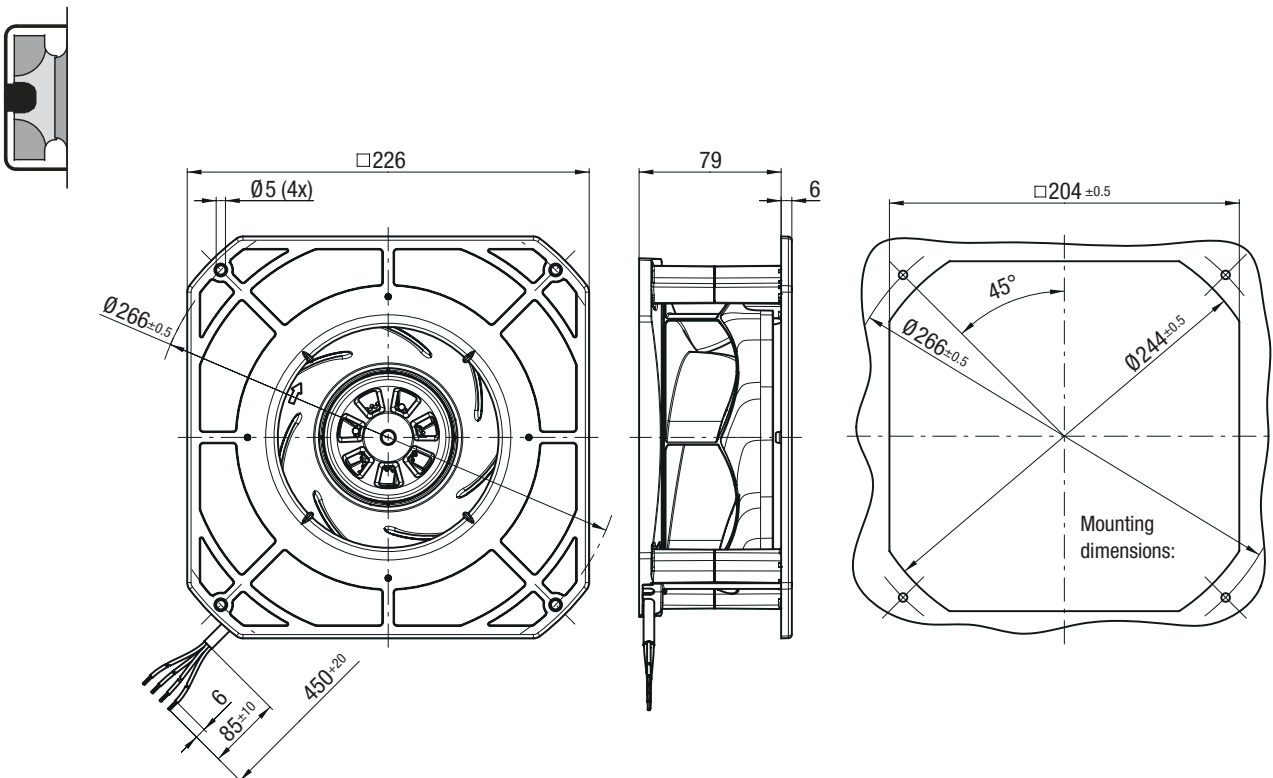

EC centrifugal fans – RadiCal

backward curved, Ø 175, 2 Speed stages, 170 W - Electronics



R3G 175-RD53-01 (Centrifugal fan)

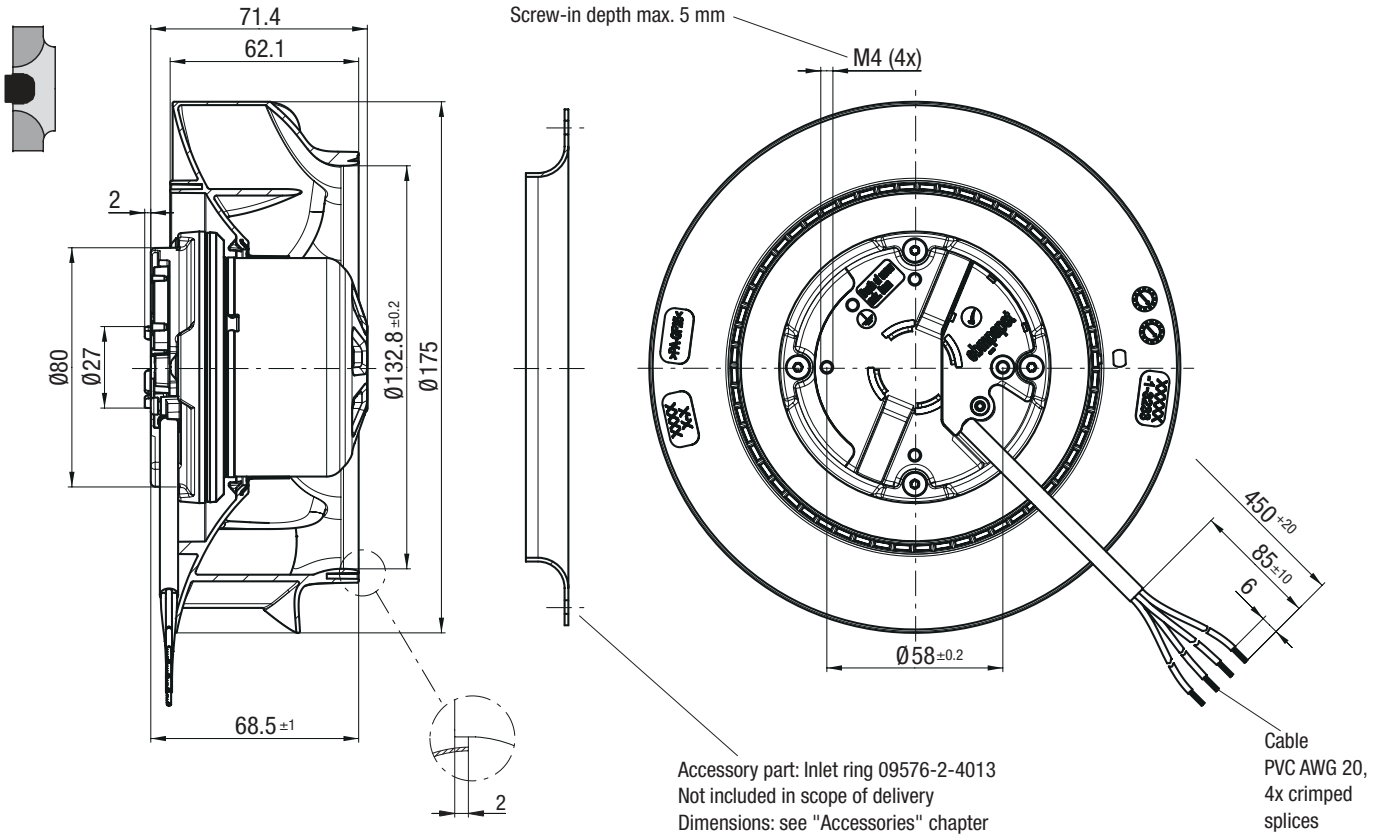

K3G 175-RD53-01 (Centrifugal module with support basket)

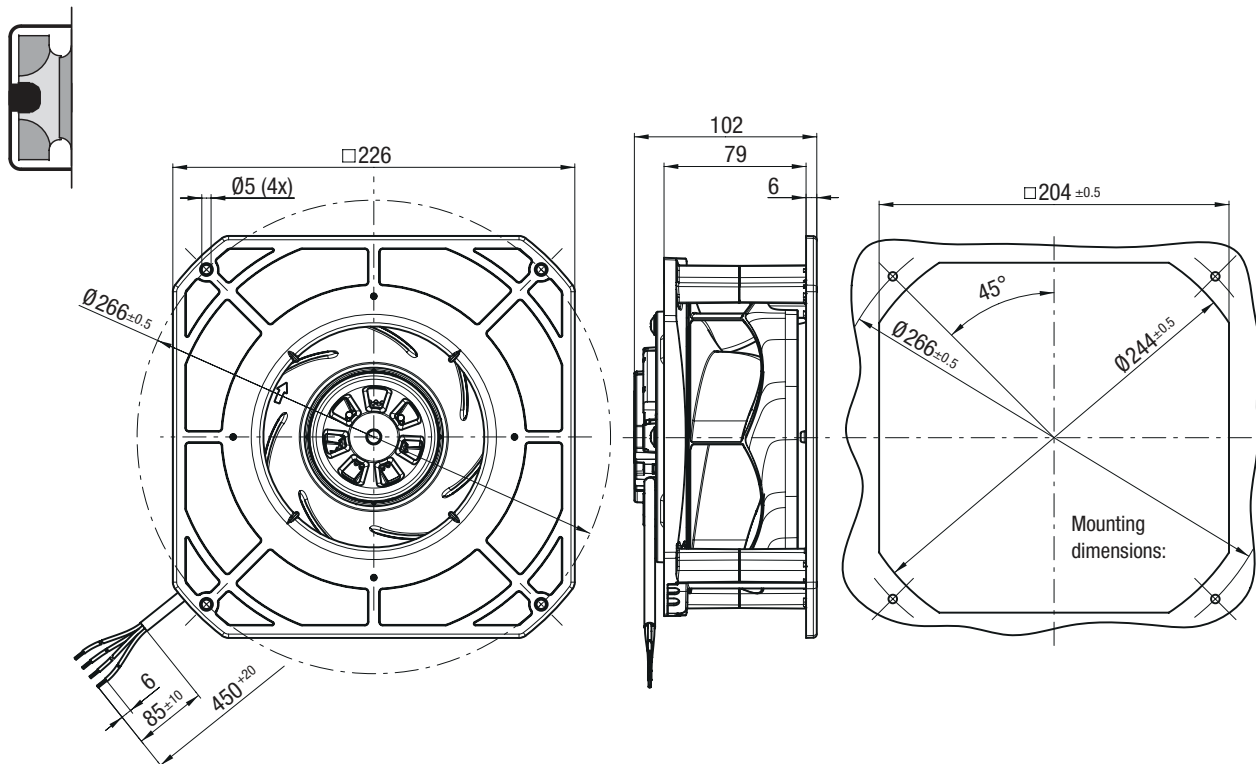

EC centrifugal fans – RadiCal

backward curved, Ø 175, Speed-controlled, 85 W - Electronics



R3G 175-RC05-03 / R3G 175-RC05-07 (Centrifugal fan)

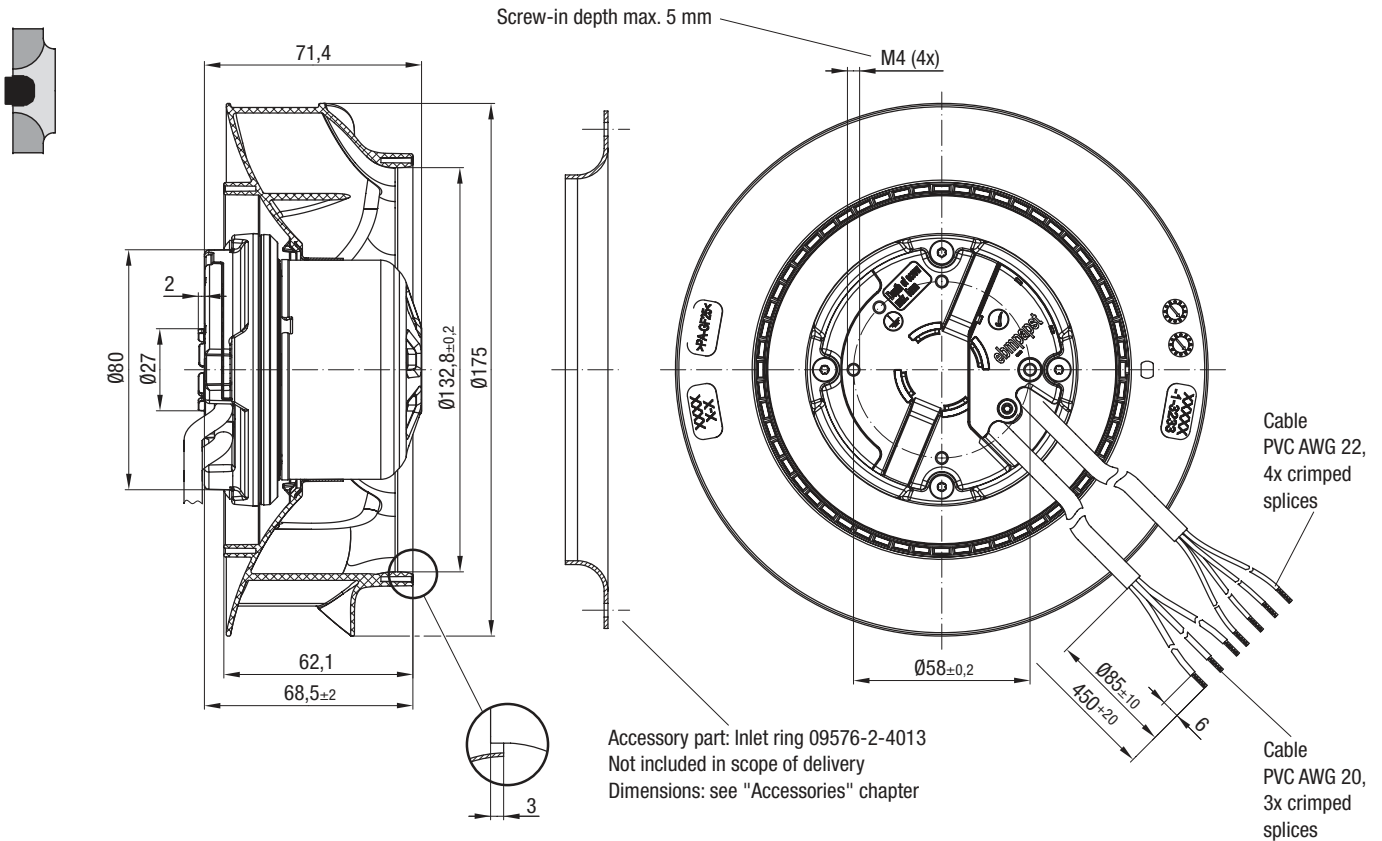

K3G 175-RC05-03 / K3G 175-RC05-07 (Centrifugal module with support basket)

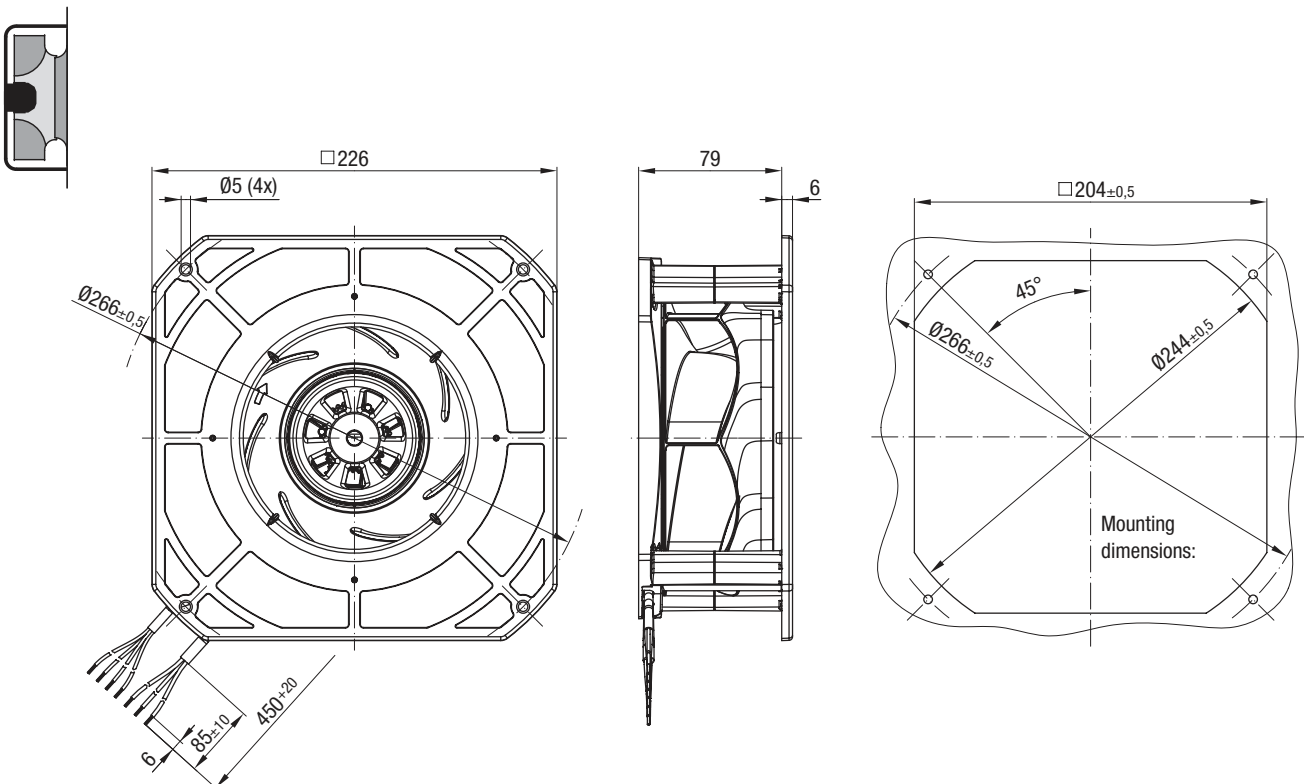

The R- and K-type cables shown refer to the 0-10 V/PWM design. For the illustration of the PWM design, see page 17.

EC centrifugal fans – RadiCal

backward curved, Ø 175, Speed-controlled, 115 W - Electronics



R3G 175-RG19-05 / R3G 175-RG19-09 (Centrifugal fan)

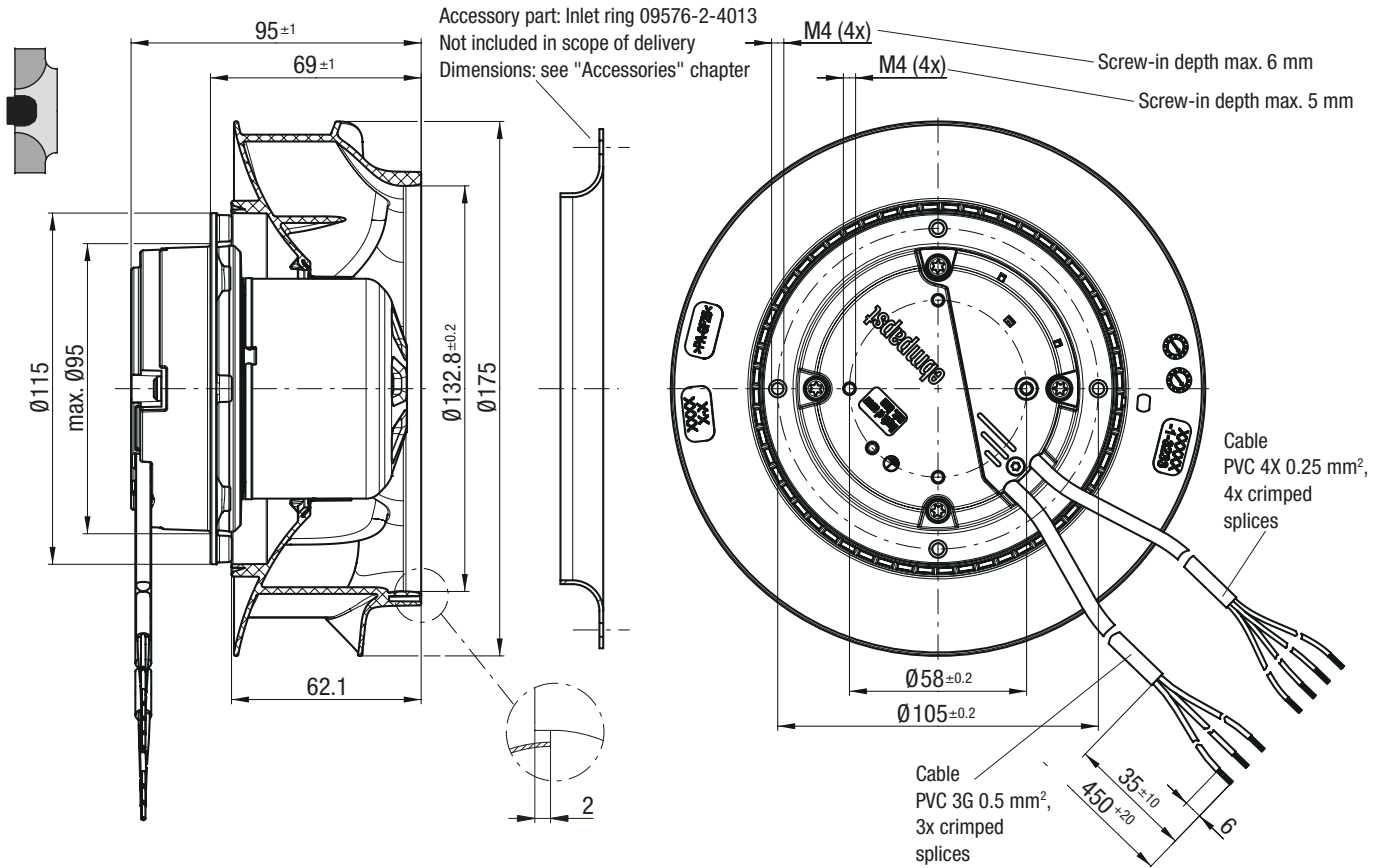

K3G 175-RG19-05 / K3G 175-RG19-09 (Centrifugal module with support basket)

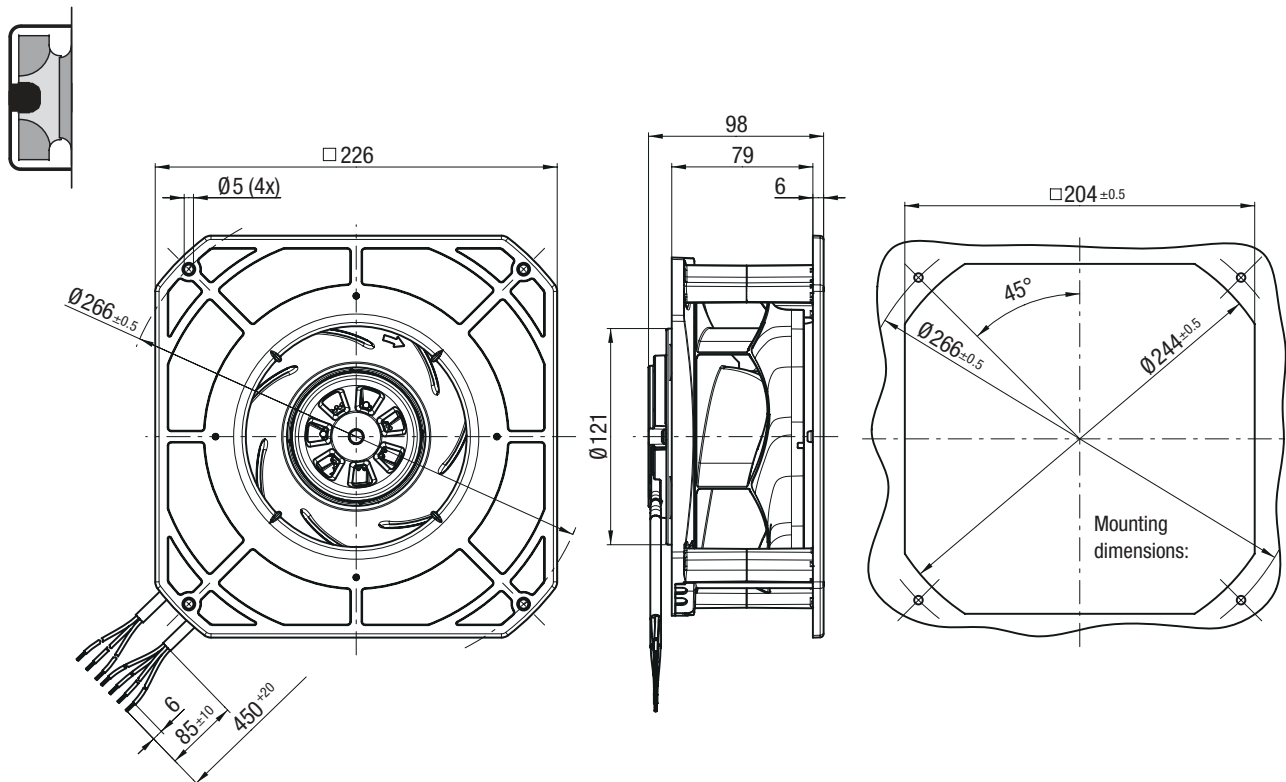

The R- and K-type cables shown refer to the 0-10 V/PWM design. For the illustration of the PWM design, see page 17.

EC centrifugal fans – RadiCal

backward curved, Ø 175, Speed-controlled, 170 W - Electronics



R3G 175-RD53-03 / R3G 175-RD53-07 / R3G 175-RD53-08 (Centrifugal fan)

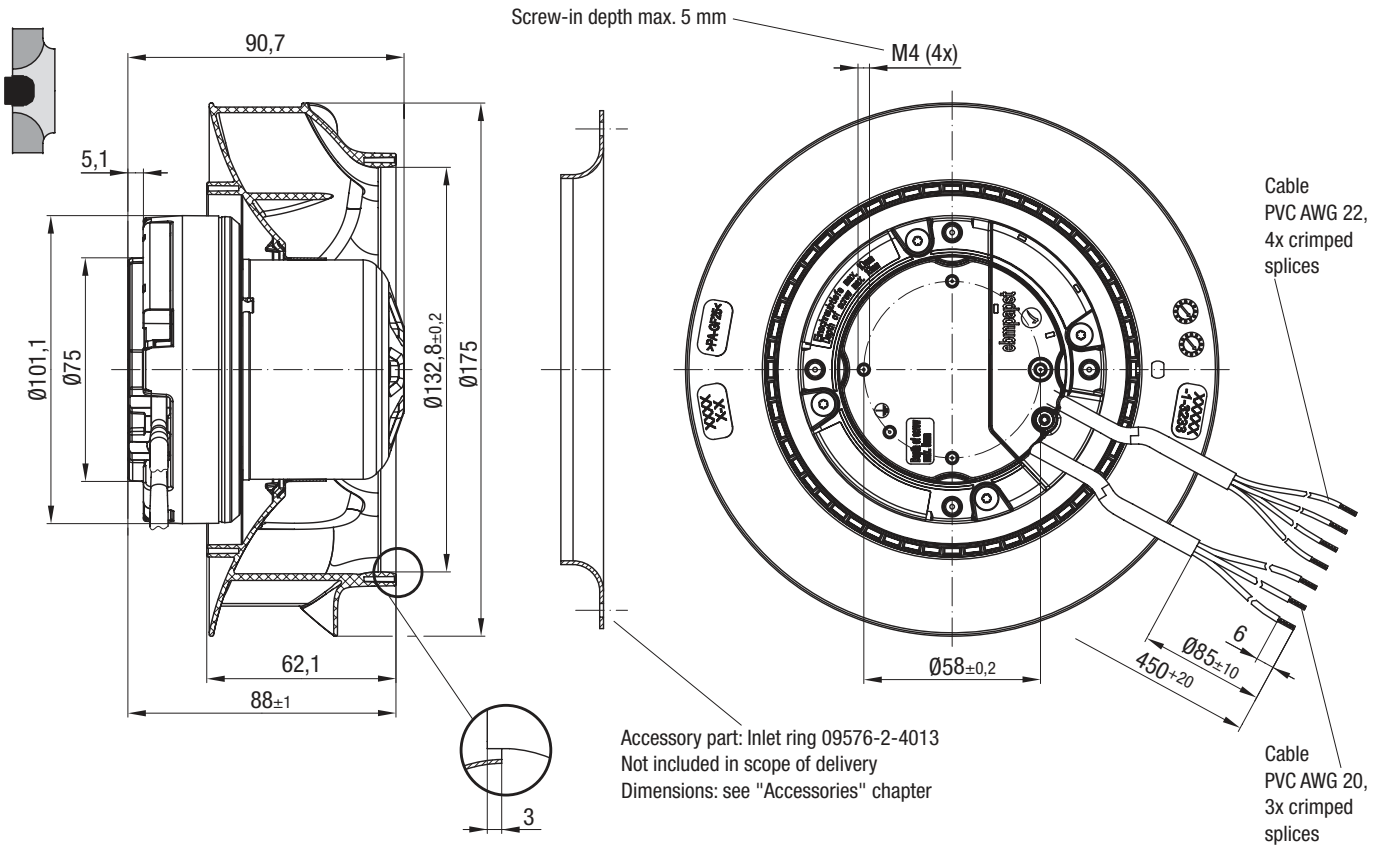

K3G 175-RD53-03 / K3G 175-RD53-07 / K3G 175-RD53-08 (Centrifugal module with support basket)

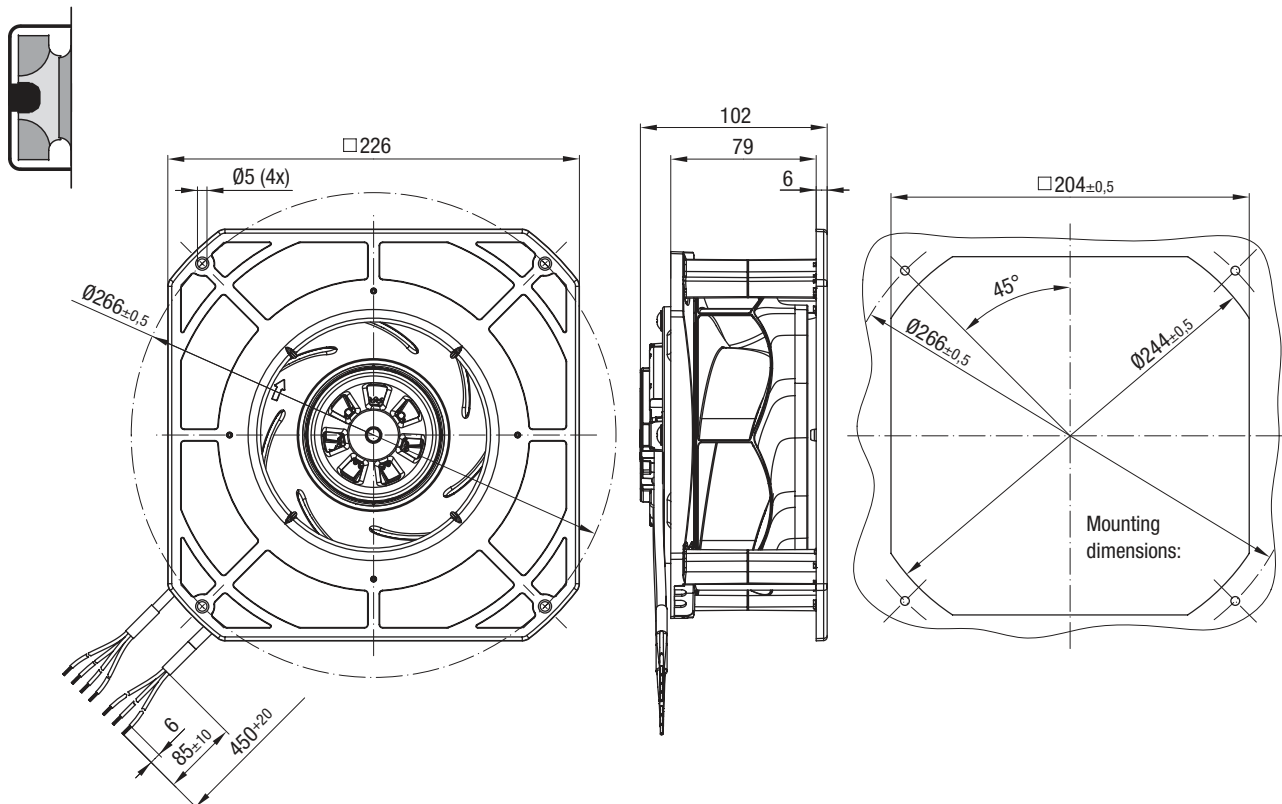

The R- and K-type cables shown refer to the 0-10 V/PWM design. For the illustration of the PWM respectively the MODBUS-RTU design, see page 17.

EC centrifugal fans – RadiCal

backward curved, Ø 190



- **Material:** Housing: Plastic
Impeller: Plastic
Rotor: Thick-film passivated
Electronics housing: Die-cast aluminium
- **Number of blades:** 7
- **Direction of rotation:** Clockwise viewed toward rotor
- **Degree of protection:** IP 54
- **Insulation class:** "B"
- **Installation position:** Any
- **Condensation drainage holes:** None, open rotor
- **Mode:** Continuous operation (S1)
- **Mounting:** Maintenance-free ball bearings

Nominal data

| Type | Motor | Curve | Nominal voltage range | Frequency | Speed ⁽¹⁾ | Max. Input power ⁽¹⁾ | Max. Input current ⁽¹⁾ | Perm. ambient temp. | Techn. features and connection diagram |
|---------|------------|-------------|-----------------------|-----------|----------------------|---------------------------------|-----------------------------------|---------------------|--|
| Type | Motor | VAC | Hz | rpm | W | A | °C | | |
| *3G 190 | M3G 055-BD | Ⓐ 1~200-240 | 50/60 | 2710 | 57 | 0,43 | -25..+60 | P. 145 / RC2) | |
| *3G 190 | M3G 055-CF | Ⓑ 1~200-240 | 50/60 | 4120 | 169 | 1,35 | -25..+60 | P. 145 / RC2) | |
| *3G 190 | M3G 055-BI | Ⓒ 1~200-240 | 50/60 | 3200 | 83 | 0,75 | -25..+60 | P. 146 / RC3) | |
| *3G 190 | M3G 055-BI | Ⓒ 1~200-240 | 50/60 | 3200 | 83 | 0,75 | -25..+60 | P. 154 / RC10) | |
| *3G 190 | M3G 055-CF | Ⓓ 1~200-240 | 50/60 | 3635 | 115 | 0,90 | -25..+55 | P. 144 / RC1) | |
| *3G 190 | M3G 055-CF | Ⓓ 1~200-240 | 50/60 | 3635 | 115 | 0,90 | -25..+55 | P. 154 / RC10) | |
| *3G 190 | M3G 055-CF | Ⓔ 1~200-240 | 50/60 | 4120 | 169 | 1,35 | -25..+60 | P. 152 / RC8) | |
| *3G 190 | M3G 055-CF | Ⓔ 1~200-240 | 50/60 | 4120 | 169 | 1,35 | -25..+60 | P. 154 / RC10) | |
| *3G 190 | M3G 055-CF | Ⓔ 1~200-240 | 50/60 | 4120 | 169 | 1,35 | -25..+60 | P. 155 / RC11) | |

Subject to change

(1) Nominal data at operating point with maximum load and 230 VAC.

Curves: 2 Speed stages

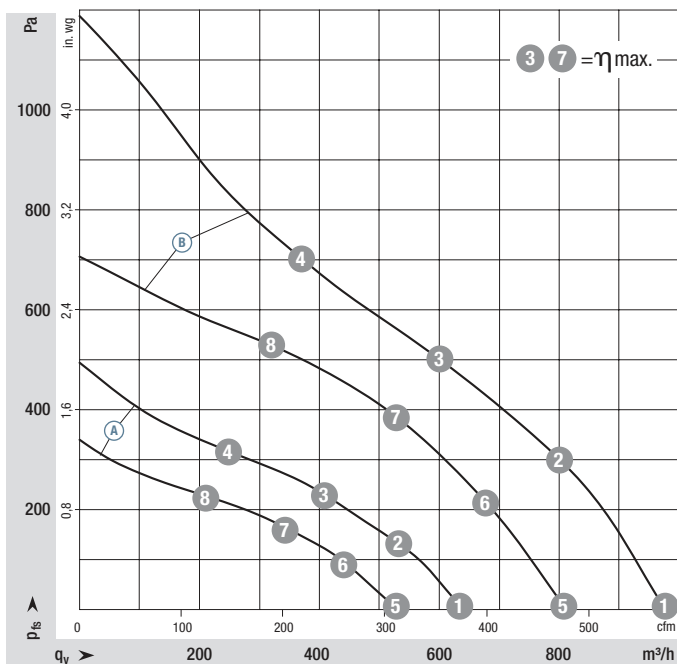

| | n rpm | P _{ed} W | I A | L _{wA} dB(A) |
|-----|-------|-------------------|------|-----------------------|
| Ⓐ ① | 2880 | 49 | 0,36 | 69 |
| Ⓐ ② | 2825 | 52 | 0,40 | 64 |
| Ⓐ ③ | 2710 | 57 | 0,43 | 62 |
| Ⓐ ④ | 2810 | 52 | 0,40 | 68 |
| Ⓐ ⑤ | 2435 | 30 | 0,23 | 65 |
| Ⓐ ⑥ | 2395 | 32 | 0,25 | 60 |
| Ⓐ ⑦ | 2325 | 35 | 0,27 | 59 |
| Ⓐ ⑧ | 2385 | 32 | 0,25 | 63 |
| Ⓑ ① | 4440 | 161 | 1,35 | 81 |
| Ⓑ ② | 4235 | 165 | 1,35 | 75 |
| Ⓑ ③ | 4120 | 169 | 1,35 | 72 |
| Ⓑ ④ | 4150 | 160 | 1,35 | 74 |
| Ⓑ ⑤ | 3720 | 95 | 0,85 | 77 |
| Ⓑ ⑥ | 3675 | 106 | 0,95 | 73 |
| Ⓑ ⑦ | 3615 | 116 | 1,01 | 69 |
| Ⓑ ⑧ | 3650 | 108 | 0,95 | 72 |

Air performance measured according to: ISO 5801, installation category A, with ebm-papst inlet ring without contact protection. Intake-side sound level: L_{wA} according to ISO 13347, L_{pA} measured at 1 m distance from fan axis. The values given are only applicable under the specified measuring conditions and may differ depending on the installation conditions. In the event of deviation from the standard configuration, the parameters must be checked in installed condition. See Page 162 ff. for detailed information.

- **Technical features:** See connection diagram P. 144 ff.
- **EMC:** Interference emission according to EN 61000-6-3
Immunity to interference according to EN 61000-6-2
Circuit feedback according to EN 61000-3-2/3
- **Touch current:** < 3,5 mA according to IEC 60990 (measuring circuit Fig. 4)
- **Cable exit:** Variable
- **Protection class:** I (with customer connection of protective earth)
- **Conformity with standards:** EN 60335-1, CE
- **Approvals:** VDE, UL, CSA, CCC, EAC on request
- **Efficiency:** Ecodesign EU regulation EU 327/2011

| Centrifugal fan | kg | Centrifugal module w. support basket | kg | 2 Speed stages | Speed-controlled 0-10 V / PWM | Speed-controlled PWM | Speed-controlled MODBUS-RTU |
|------------------|------|--------------------------------------|------|----------------|-------------------------------|----------------------|-----------------------------|
| R3G 190-RB01 -01 | 0,85 | K3G 190-RB01 -01 | 1,40 | X | | | |
| R3G 190-RD45 -01 | 1,35 | K3G 190-RD45 -01 | 1,90 | X | | | |
| R3G 190-RC05 -03 | 1,05 | K3G 190-RC05 -03 | 1,60 | | X | | |
| R3G 190-RC05 -05 | 1,05 | K3G 190-RC05 -05 | 1,60 | | | X | |
| R3G 190-RG19 -01 | 1,40 | K3G 190-RG19 -01 | 1,60 | | X | | |
| R3G 190-RG19 -05 | 1,40 | K3G 190-RG19 -05 | 1,60 | | | X | |
| R3G 190-RD45 -03 | 1,35 | K3G 190-RD45 -03 | 1,90 | | X | | |
| R3G 190-RD45 -05 | 1,35 | K3G 190-RD45 -05 | 1,90 | | | X | |
| R3G 190-RD45 -08 | 1,35 | K3G 190-RD45 -08 | 1,90 | | | | X |

(2) PVC AWG 20, 4x splices (3) PVC AWG 20, 3x splices (4) PVC AWG 22, 4x splices (5) PVC AWG 20, 3x splices (6) PVC AWG 22, 3x splices (7) PVC AWG 20, 3x splices (8) PVC AWG 22, 5x splices

Curves:
Speed-controlled
0-10 V / PWM
PWM
MODBUS-RTU

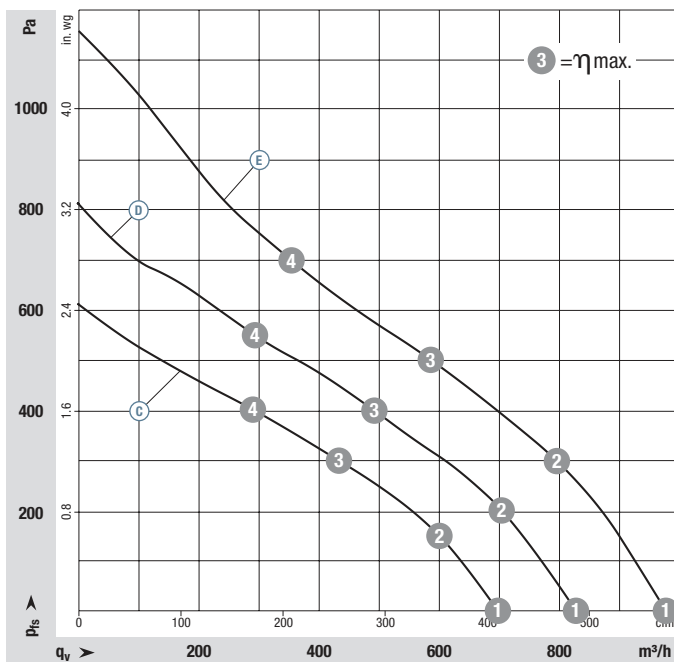

| | n rpm | P _{ed} W | I A | L _{wA} dB(A) |
|-----|-------|-------------------|------|-----------------------|
| ⓐ 1 | 3420 | 75 | 0,67 | 73 |
| ⓐ 2 | 3360 | 79 | 0,70 | 68 |
| ⓐ 3 | 3200 | 83 | 0,75 | 66 |
| ⓐ 4 | 3275 | 83 | 0,73 | 69 |
| ⓓ 1 | 3960 | 110 | 0,90 | 77 |
| ⓓ 2 | 3870 | 115 | 0,90 | 73 |
| ⓓ 3 | 3635 | 115 | 0,90 | 70 |
| ⓓ 4 | 3805 | 115 | 0,90 | 74 |
| ⓔ 1 | 4440 | 161 | 1,35 | 81 |
| ⓔ 2 | 4230 | 165 | 1,35 | 75 |
| ⓔ 3 | 4120 | 169 | 1,35 | 71 |
| ⓔ 4 | 4180 | 160 | 1,35 | 75 |

Air performance measured according to: ISO 5801, installation category A, with ebm-papst inlet ring without contact protection. Intake-side sound level: L_{wA} according to ISO 13347, L_{pA} measured at 1 m distance from fan axis. The values given are only applicable under the specified measuring conditions and may differ depending on the installation conditions. In the event of deviation from the standard configuration, the parameters must be checked in installed condition. See Page 162 ff. for detailed information.

EC centrifugal fans – RadiCal

backward curved, Ø 190, 2 Speed stages, 85 W - Electronics



R3G 190-RB01-01 (Centrifugal fan)

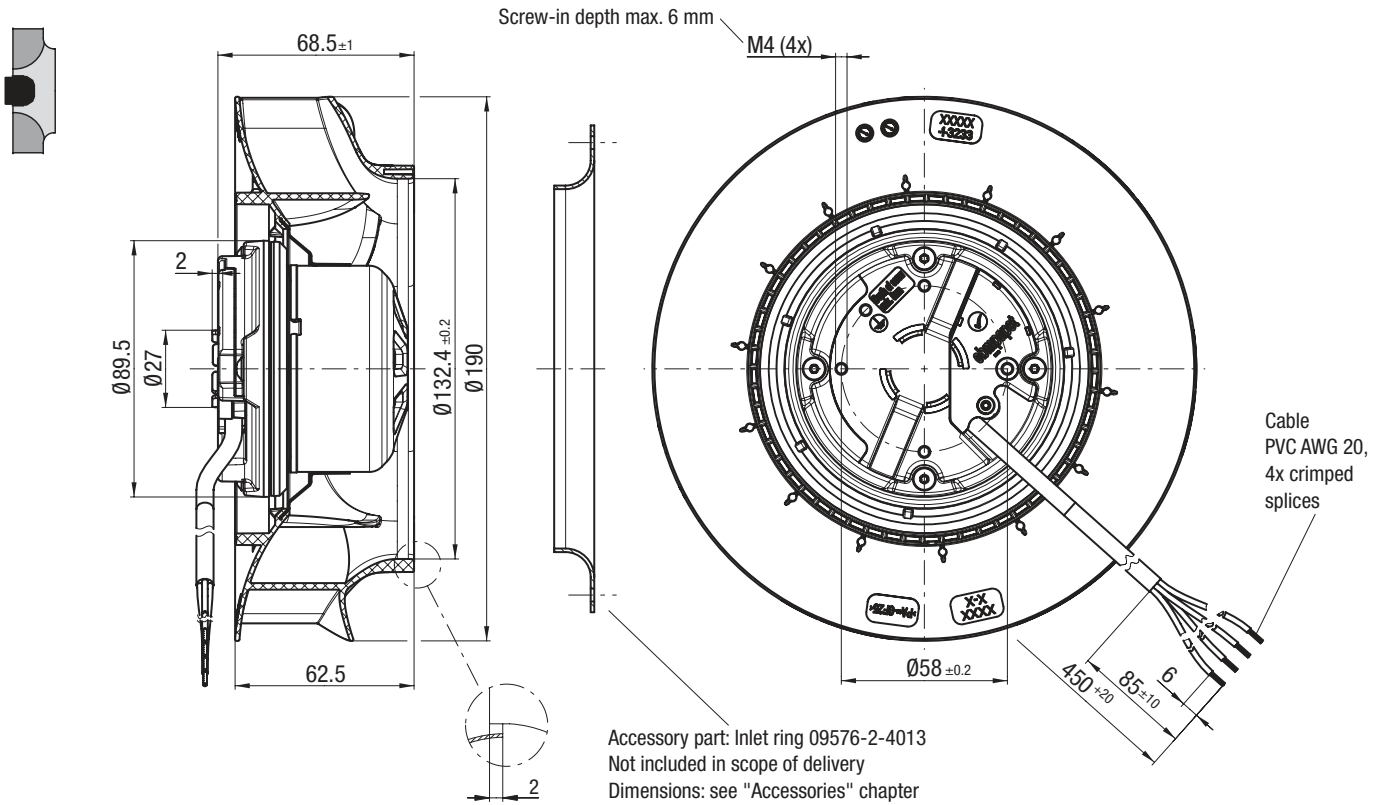

K3G 190-RB01-01 (Centrifugal module with support basket)

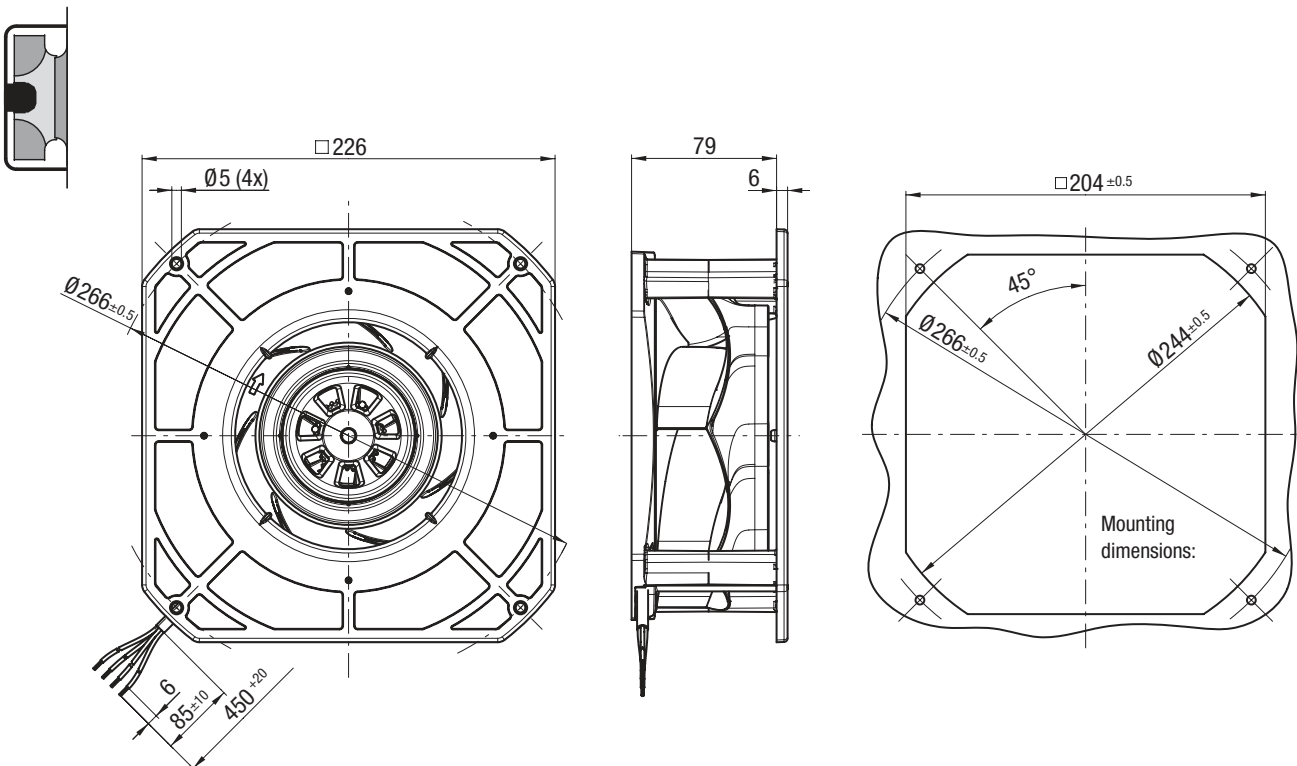

EC centrifugal fans – RadiCal

backward curved, Ø 190, 2 Speed stages, 170 W - Electronics



R3G 190-RD45-01 (Centrifugal fan)

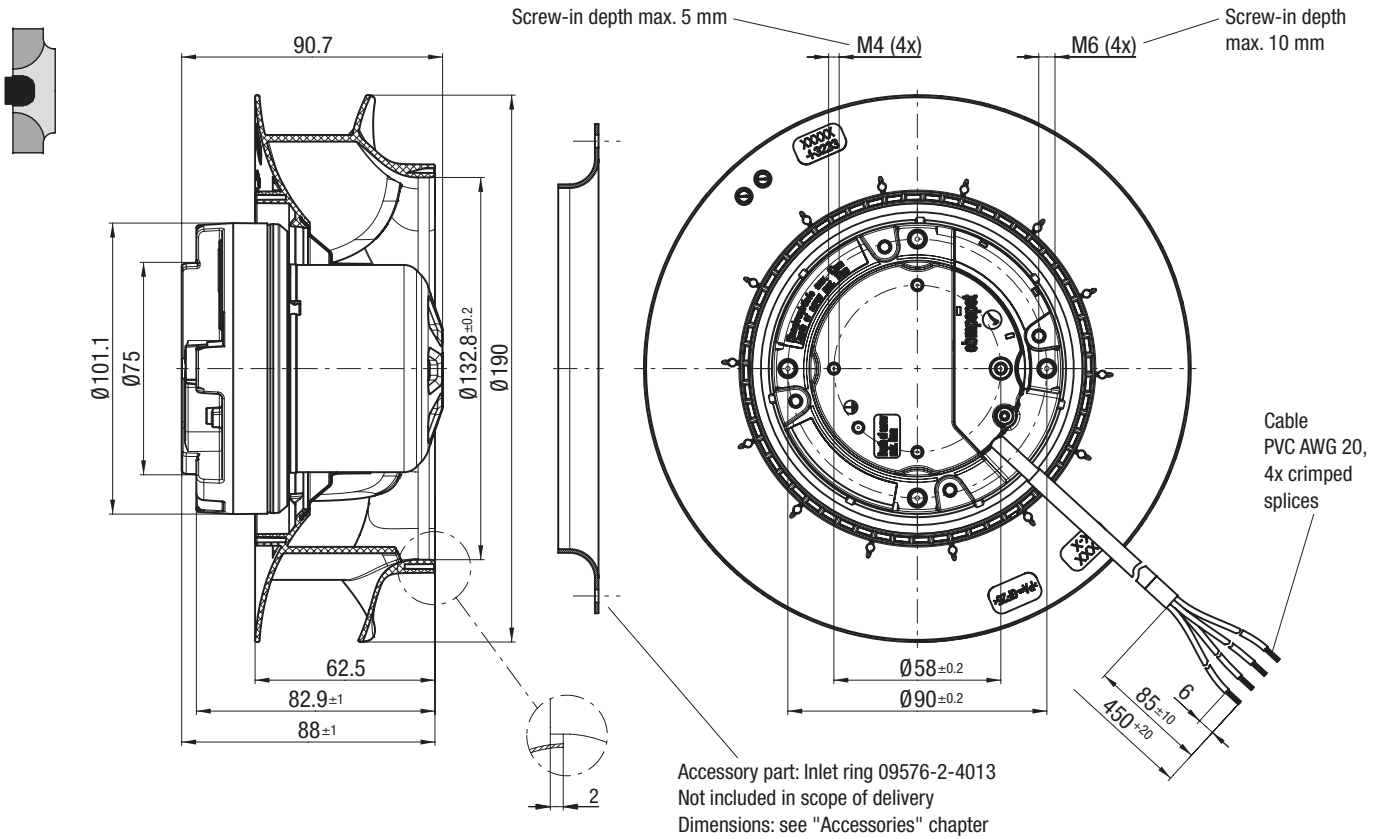

K3G 190-RD45-01 (Centrifugal module with support basket)

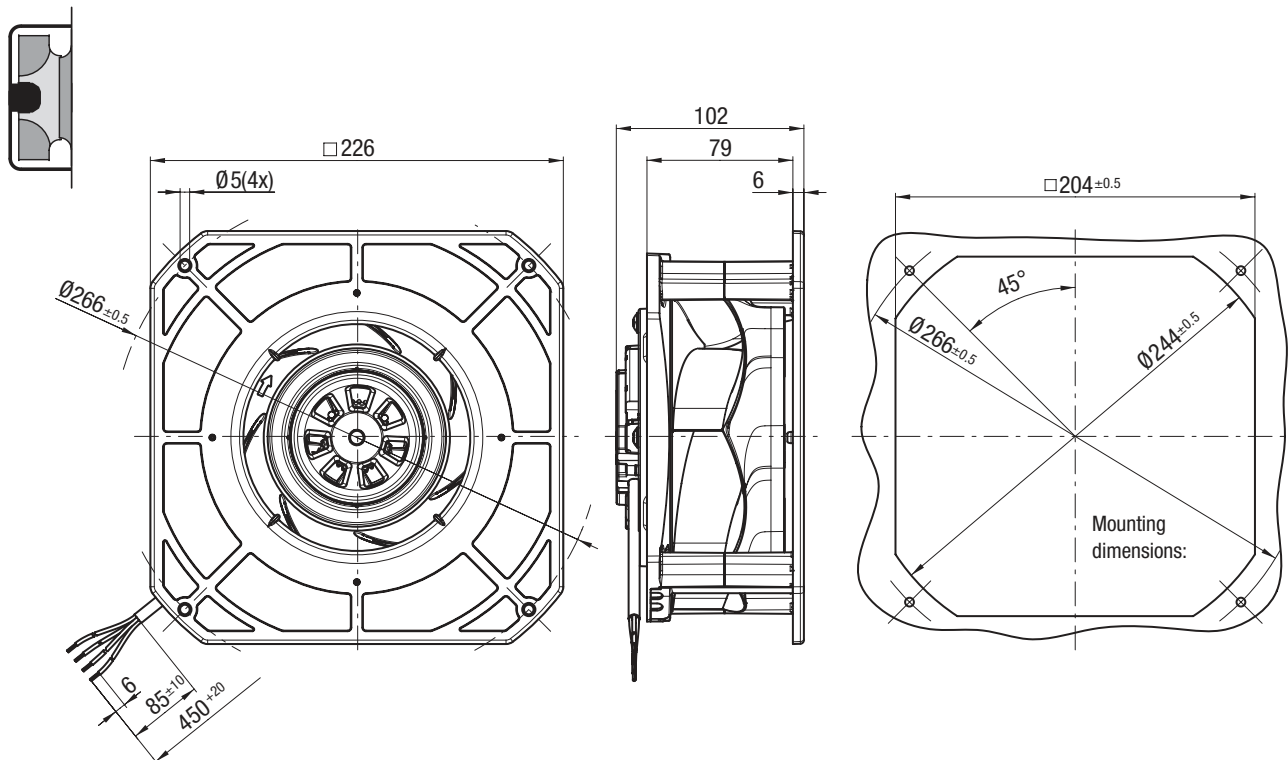

EC centrifugal fans – RadiCal

backward curved, Ø 190, Speed-controlled, 85 W - Electronics



R3G 190-RC05-03 / R3G 190-RC05-05 (Centrifugal fan)

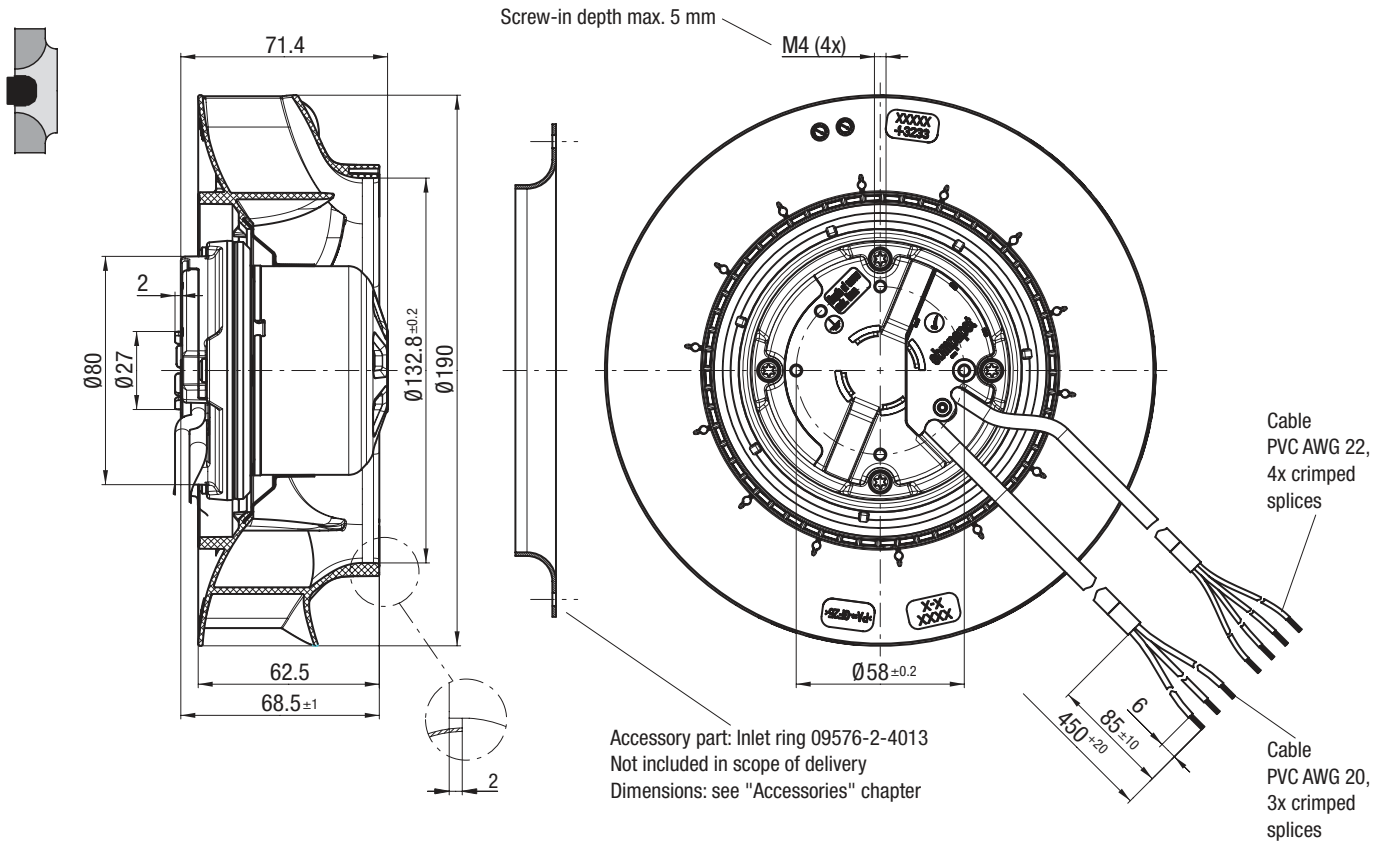

K3G 190-RC05-03 / K3G 190-RC05-05 (Centrifugal module with support basket)

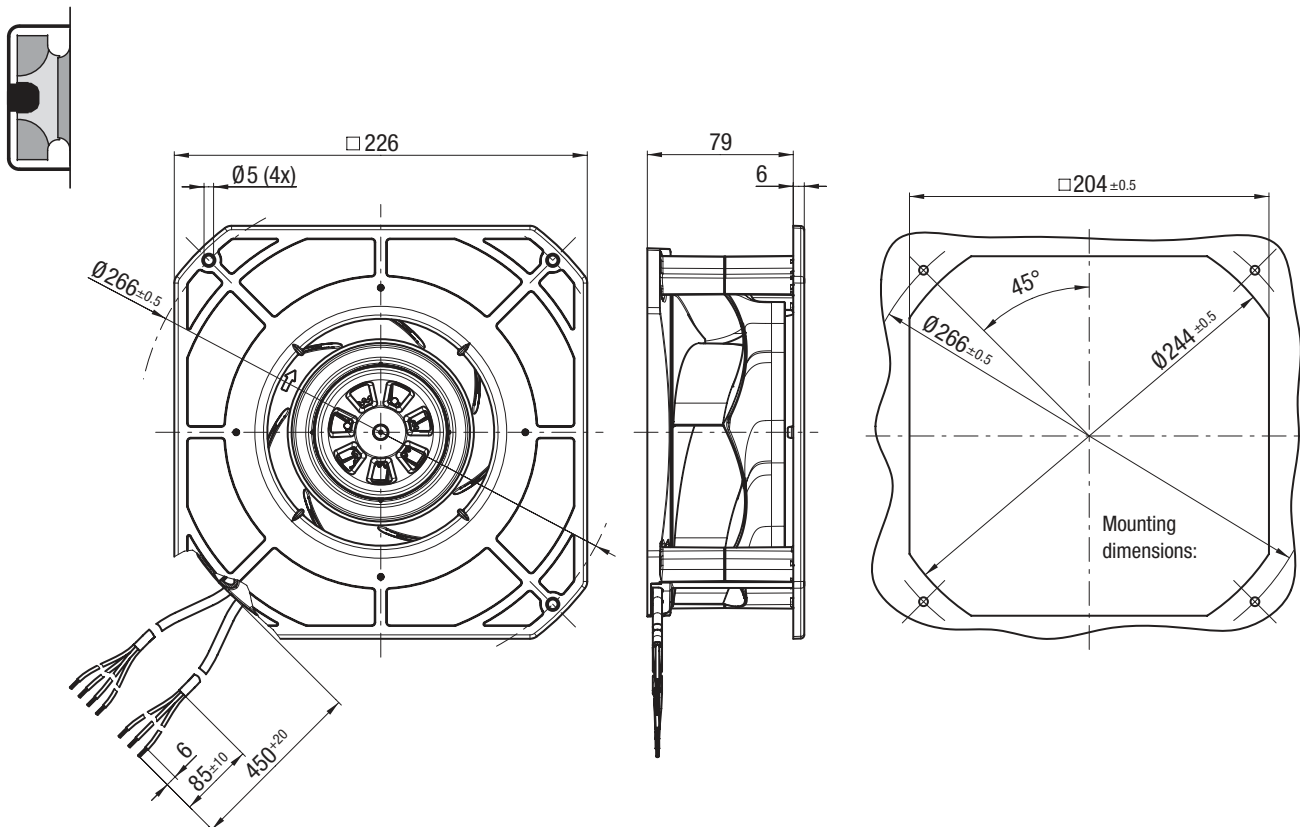

The R- and K-type cables shown refer to the 0-10 V/PWM design. For the illustration of the PWM design, see page 25.

EC centrifugal fans – RadiCal

backward curved, Ø 190, Speed-controlled, 115 W - Electronics



R3G 190-RG19-01 / R3G 190-RG19-05 (Centrifugal fan)

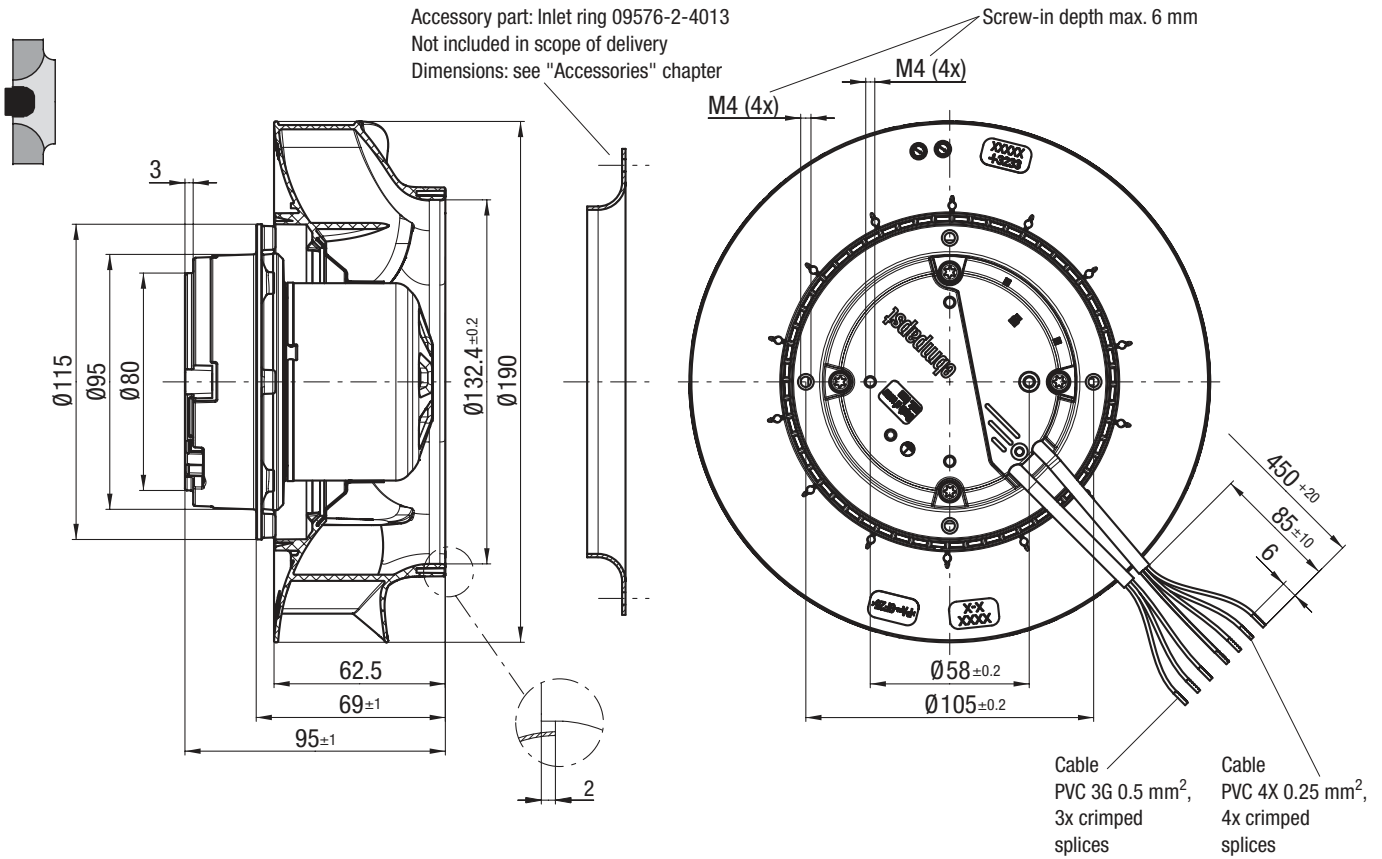

K3G 190-RG19-01 / K3G 190-RG19-05 (Centrifugal module with support basket)

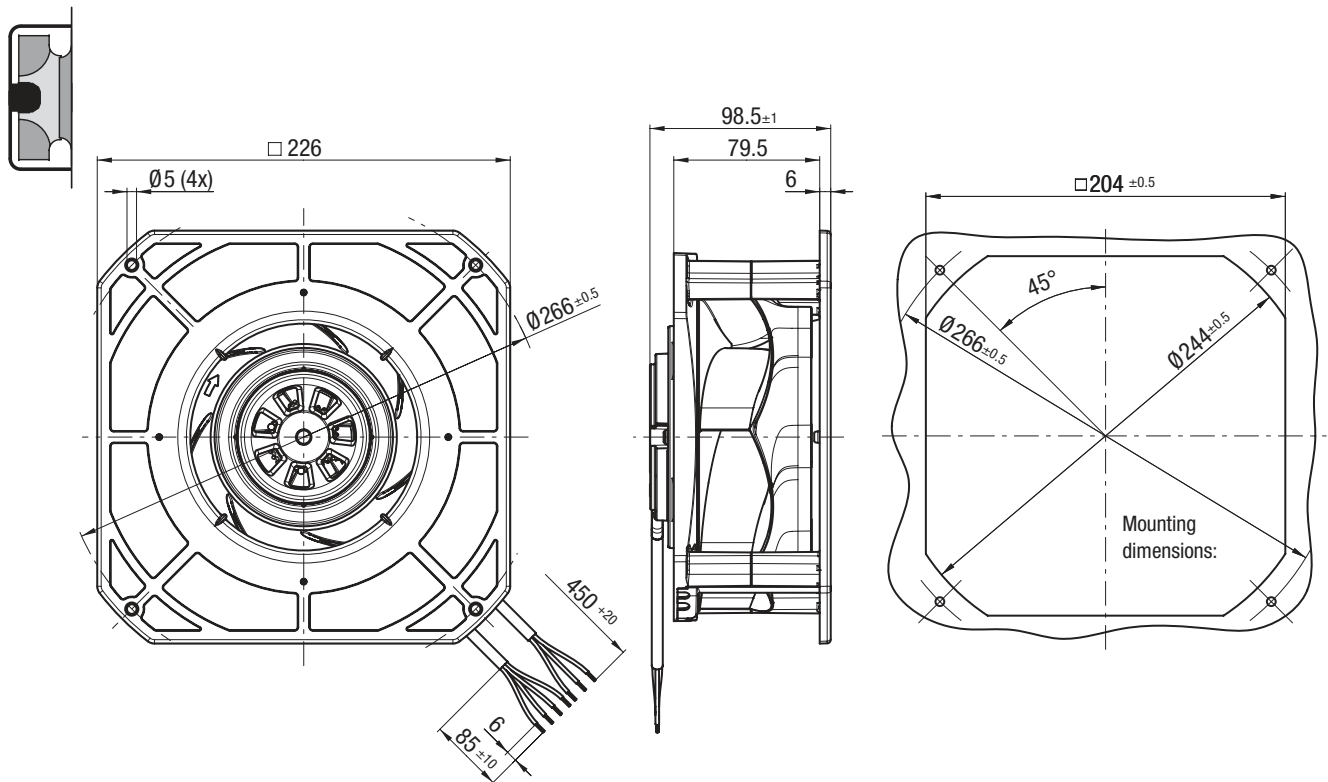

The R- and K-type cables shown refer to the 0-10 V/PWM design. For the illustration of the PWM design, see page 25.

EC centrifugal fans – RadiCal

backward curved, Ø 190, Speed-controlled, 170 W - Electronics



R3G 190-RD45-03 / R3G 190-RD45-05 / R3G 190-RD45-08 (Centrifugal fan)

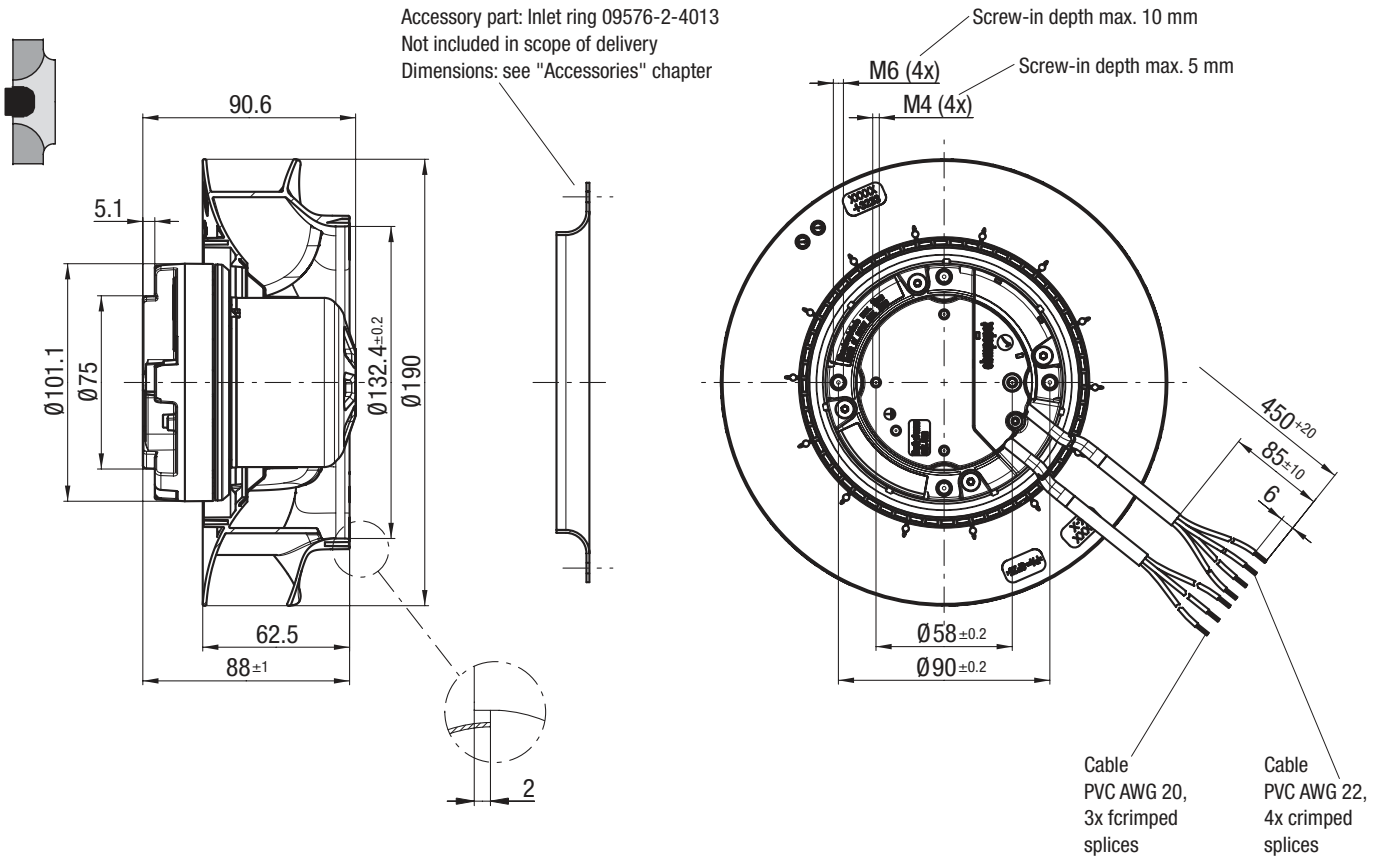

K3G 190-RD45-03 / K3G 190-RD45-05 / K3G 190-RD45-08 (Centrifugal module with support basket)

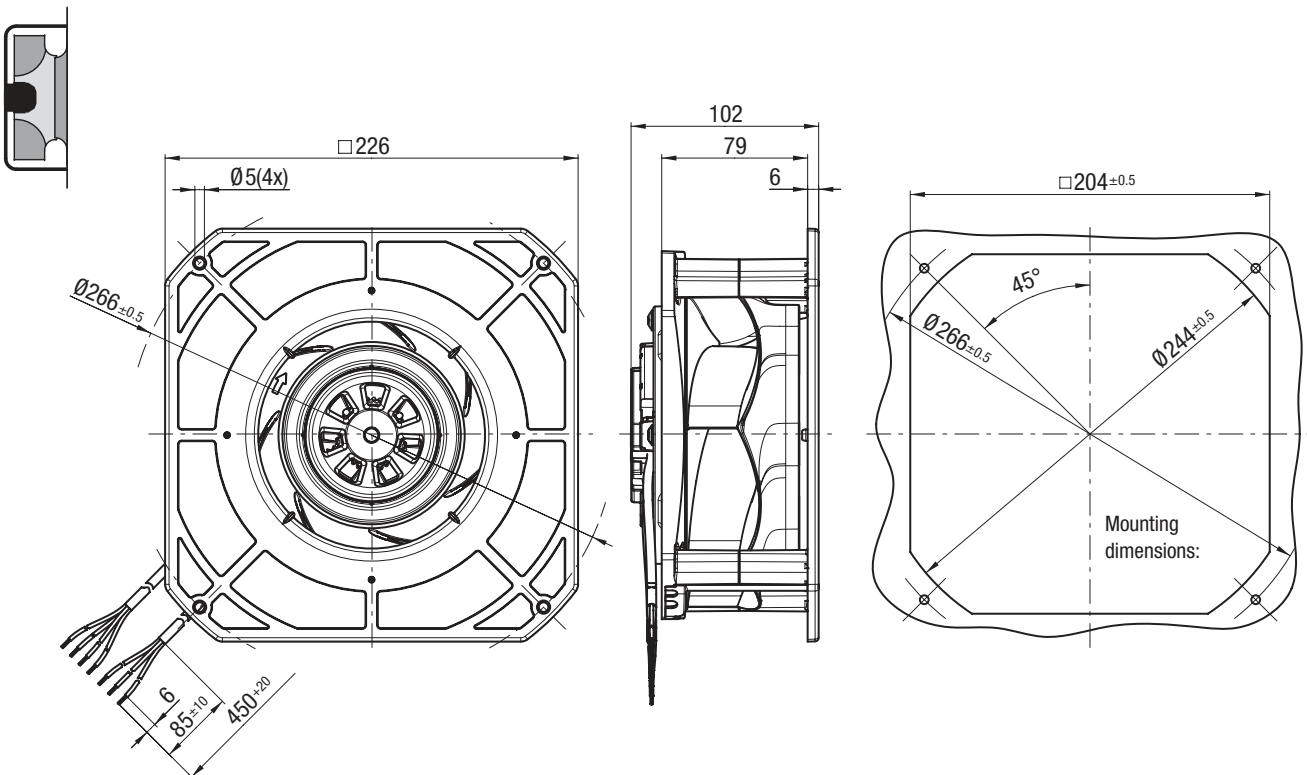

The R- and K-type cables shown refer to the 0-10 V/PWM design. For the illustration of the PWM respectively the MODBUS-RTU design, see page 25.

EC centrifugal fans – RadiCal

backward curved, with housing, Ø 190



- **Material:** Housing: Plastic
Impeller: Plastic
Rotor: Thick-film passivated
 - ⓑ ⓐ ⓓ Electronics housing: Die-cast aluminium
 - ⓐ ⓔ Electronics cap: Sheet steel, hot-dip aluminized
- **Number of blades:** 7
- **Direction of rotation:** Clockwise viewed toward rotor
- **Degree of protection:** ⓑ ⓐ ⓓ IP 54, ⓐ ⓔ IP 20; depending on installation and position
- **Insulation class:** "B"
- **Installation position:** Any
- **Condensation drainage holes:** None, open rotor
- **Mode:** Continuous operation (S1)
- **Mounting:** Maintenance-free ball bearings

| Nominal data | | Curve | Nominal voltage range | Frequency | Speed ⁽¹⁾ | Max. Input power ⁽¹⁾ | Max. Input current ⁽¹⁾ | Perm. ambient temp. | Techn. features and connection diagram |
|--------------|------------|-------------|-----------------------|-----------|----------------------|---------------------------------|-----------------------------------|---------------------|--|
| Type | Motor | VAC | Hz | rpm | W | A | °C | | |
| *3G 190 | M3G 055-BI | ⓐ 1~200-240 | 50/60 | 3050 | 72 | 0,70 | -25..+60 | P. 156 / RC12) | |
| *3G 190 | M3G 055-BI | ⓑ 1~200-240 | 50/60 | 3200 | 83 | 0,75 | -25..+60 | P. 146 / RC3) | |
| *3G 190 | M3G 055-BI | ⓑ 1~200-240 | 50/60 | 3200 | 83 | 0,75 | -25..+60 | P. 154 / RC10) | |
| *3G 190 | M3G 055-CF | ⓒ 1~200-240 | 50/60 | 3650 | 115 | 0,90 | -25..+55 | P. 144 / RC1) | |
| *3G 190 | M3G 055-CF | ⓒ 1~200-240 | 50/60 | 3650 | 115 | 0,90 | -25..+55 | P. 154 / RC10) | |
| *3G 190 | M3G 055-CF | ⓓ 1~200-240 | 50/60 | 4100 | 170 | 1,35 | -25..+60 | P. 152 / RC8) | |
| *3G 190 | M3G 055-CF | ⓓ 1~200-240 | 50/60 | 4100 | 170 | 1,35 | -25..+60 | P. 154 / RC10) | |
| *3G 190 | M3G 055-CF | ⓓ 1~200-240 | 50/60 | 4100 | 170 | 1,35 | -25..+60 | P. 155 / RC11) | |
| *3G 190 | M3G 055-CF | ⓔ 1~200-240 | 50/60 | 4150 | 170 | 1,35 | -25..+50 | P. 156 / RC12) | |

Subject to change

(1) Nominal data at operating point with maximum load and 230 VAC.

Curves:
Speed-controlled
0-10 V / PWM
PWM
MODBUS-RTU

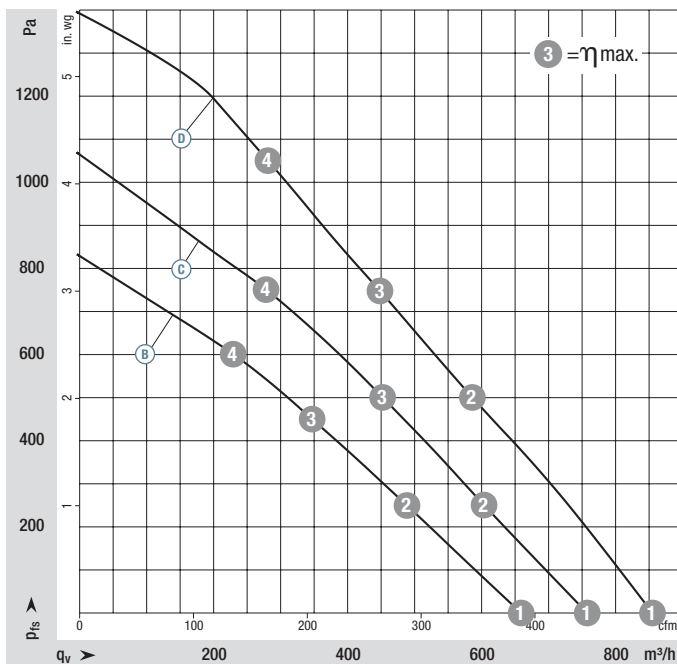

| | n rpm | P _{ed} W | I A | L _{wA} dB(A) |
|-----|-------|-------------------|------|-----------------------|
| ⓑ ① | 3355 | 83 | 0,75 | 73 |
| ⓑ ② | 3200 | 83 | 0,75 | 68 |
| ⓑ ③ | 3230 | 83 | 0,75 | 68 |
| ⓑ ④ | 3380 | 83 | 0,75 | 71 |
| ⓒ ① | 3805 | 115 | 0,90 | 76 |
| ⓒ ② | 3650 | 115 | 0,90 | 71 |
| ⓒ ③ | 3660 | 115 | 0,90 | 70 |
| ⓒ ④ | 3815 | 115 | 0,90 | 73 |
| ⓓ ① | 4335 | 170 | 1,35 | 80 |
| ⓓ ② | 4100 | 170 | 1,35 | 74 |
| ⓓ ③ | 4165 | 170 | 1,35 | 74 |
| ⓓ ④ | 4440 | 170 | 1,35 | 79 |

Air performance measured according to: ISO 5801, installation category A, with ebm-papst inlet ring without contact protection. Intake-side sound level: L_{wA} according to ISO 13347, L_{pA} measured at 1 m distance from fan axis. The values given are only applicable under the specified measuring conditions and may differ depending on the installation conditions. In the event of deviation from the standard configuration, the parameters must be checked in installed condition. See Page 162 ff. for detailed information.

- **Technical features:** See connection diagram P. 144 ff.
- **Touch current:** $\leq 3,5$ mA according to IEC 60990 (measuring circuit Fig. 4)
- **Cable exit:** Variable
- **Protection class:** I (with customer connection of protective earth)
- **Conformity with standards:** EN 60335-1; CE
- **Approvals:** VDE, UL, CSA, CCC, EAC on request
- **Efficiency:** Ecodesign EU regulation EU 327/2011



Weight Centrifugal fan with housing

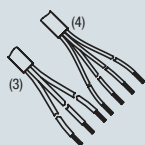

Cables

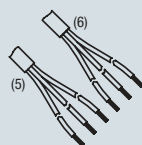

Cables

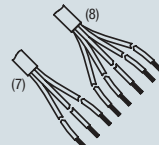

Cables

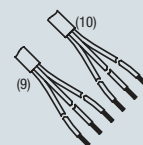

Cables

| Centrifugal fan with housing | kg | Speed-controlled 0-10 V / PWM | Speed-controlled PWM | Speed-controlled MODBUS-RTU | Sensor-controlled MODBUS-RTU |
|----------------------------------|------|-------------------------------|----------------------|-----------------------------|------------------------------|
| G3G 190-RP03 -04 ⁽¹¹⁾ | 2,00 | | | | X |
| G3G 190-RC05 -02 | 2,10 | X | | | |
| G3G 190-RC05 -05 | 2,10 | | X | | |
| G3G 190-RG19 -01 | 2,00 | X | | | |
| G3G 190-RG19 -05 | 2,00 | | X | | |
| G3G 190-RD45 -03 | 2,10 | X | | | |
| G3G 190-RD45 -05 | 2,10 | | X | | |
| G3G 190-RD45 -08 | 2,10 | | | X | |
| G3G 190-RQ45 -04 ⁽¹¹⁾ | 2,20 | | | | X |

(11) Freely programmable volume flows (constant air flow volume with tolerance related $\pm 1\%$ of final value)

(3) PVC AWG 20, 3x splices
(4) PVC AWG 22, 4x splices

(5) PVC AWG 20, 3x splices
(6) PVC AWG 22, 3x splices

(7) PVC AWG 20, 3x splices
(8) PVC AWG 22, 5x splices

(9) PVC AWG 20, 3x splices
(10) PVC AWG 22, 3x splices

Curves:
Sensor-controlled
MODBUS-RTU

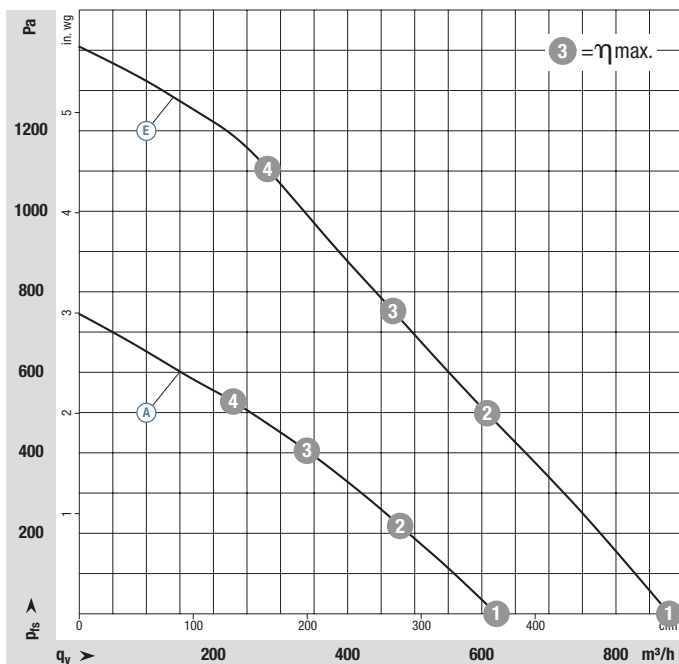

| | n rpm | P _{ed} W | I A | L _{wA} dB(A) |
|-------|-------|-------------------|------|-----------------------|
| (A) 1 | 3125 | 70 | 0,66 | 74 |
| (A) 2 | 3050 | 72 | 0,70 | 69 |
| (A) 3 | 3095 | 71 | 0,67 | 66 |
| (A) 4 | 3200 | 65 | 0,61 | 70 |
| (E) 1 | 4345 | 170 | 1,35 | 82 |
| (E) 2 | 4150 | 170 | 1,35 | 75 |
| (E) 3 | 4210 | 170 | 1,35 | 74 |
| (E) 4 | 4535 | 170 | 1,35 | 79 |

Air performance measured according to: ISO 5801, installation category A, with ebm-papst inlet ring without contact protection. Intake-side sound level: L_{wA} according to ISO 13347, L_{pA} measured at 1 m distance from fan axis. The values given are only applicable under the specified measuring conditions and may differ depending on the installation conditions. In the event of deviation from the standard configuration, the parameters must be checked in installed condition. See Page 162 ff. for detailed information.

EC centrifugal fans – RadiCal

backward curved, with housing, Ø 190



G3G 190-RC05-02 / G3G 190-RC05-05 (Centrifugal fan with housing) / Speed-controlled, 85 W - Electronics

Tapping hole prepared for self-tapping screw for fastening plastics (Remform) dia. 4 mm, screw-in depth max. 15 mm. The torque is to be determined on the basis of the screw.

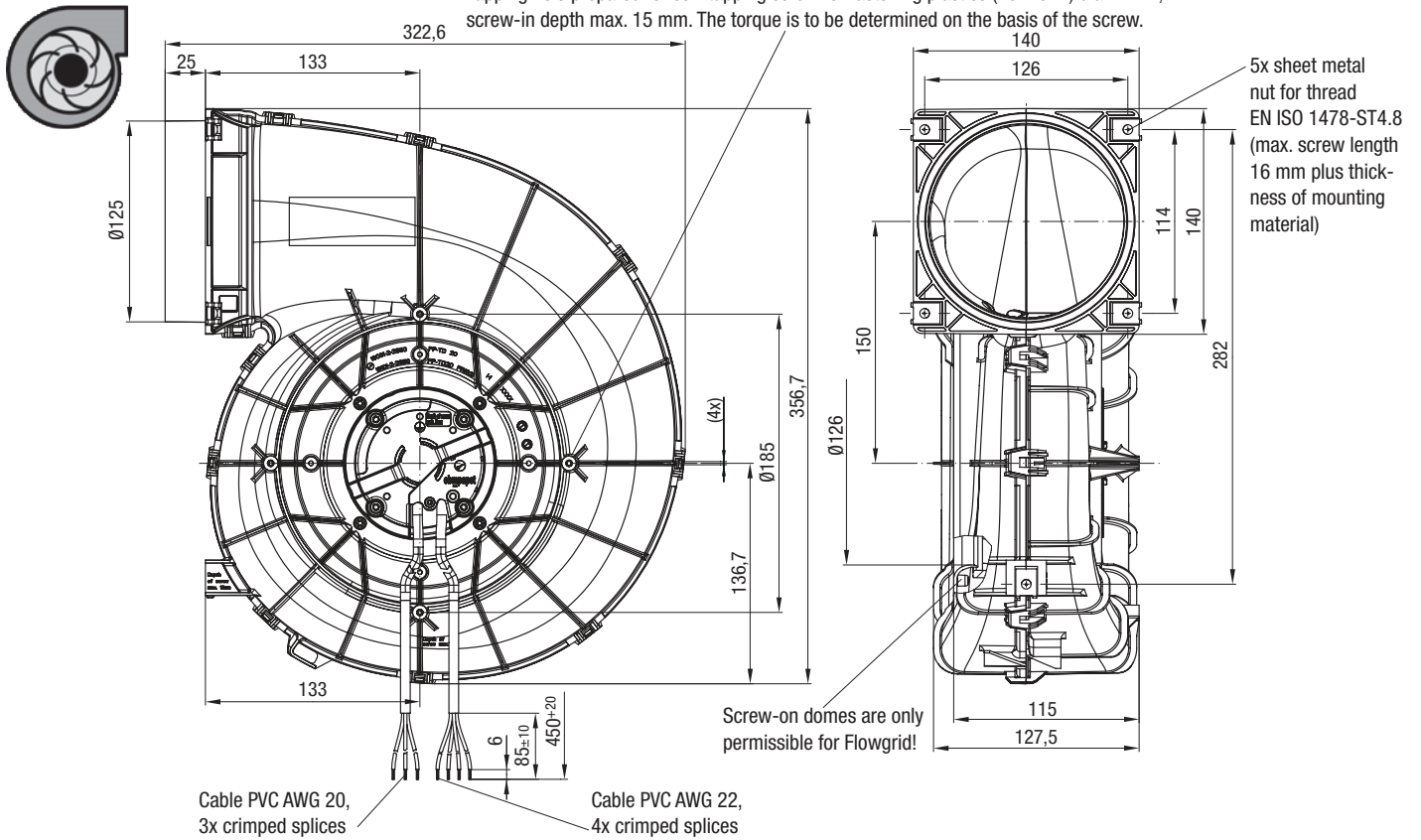

G3G 190-RG19-01 / G3G 190-RG19-05 (Centrifugal fan with housing) / Speed-controlled, 115 W - Electronics

Tapping hole prepared for self-tapping screw for fastening plastics (Remform) dia. 4 mm, screw-in depth max. 15 mm. The torque is to be determined on the basis of the screw.

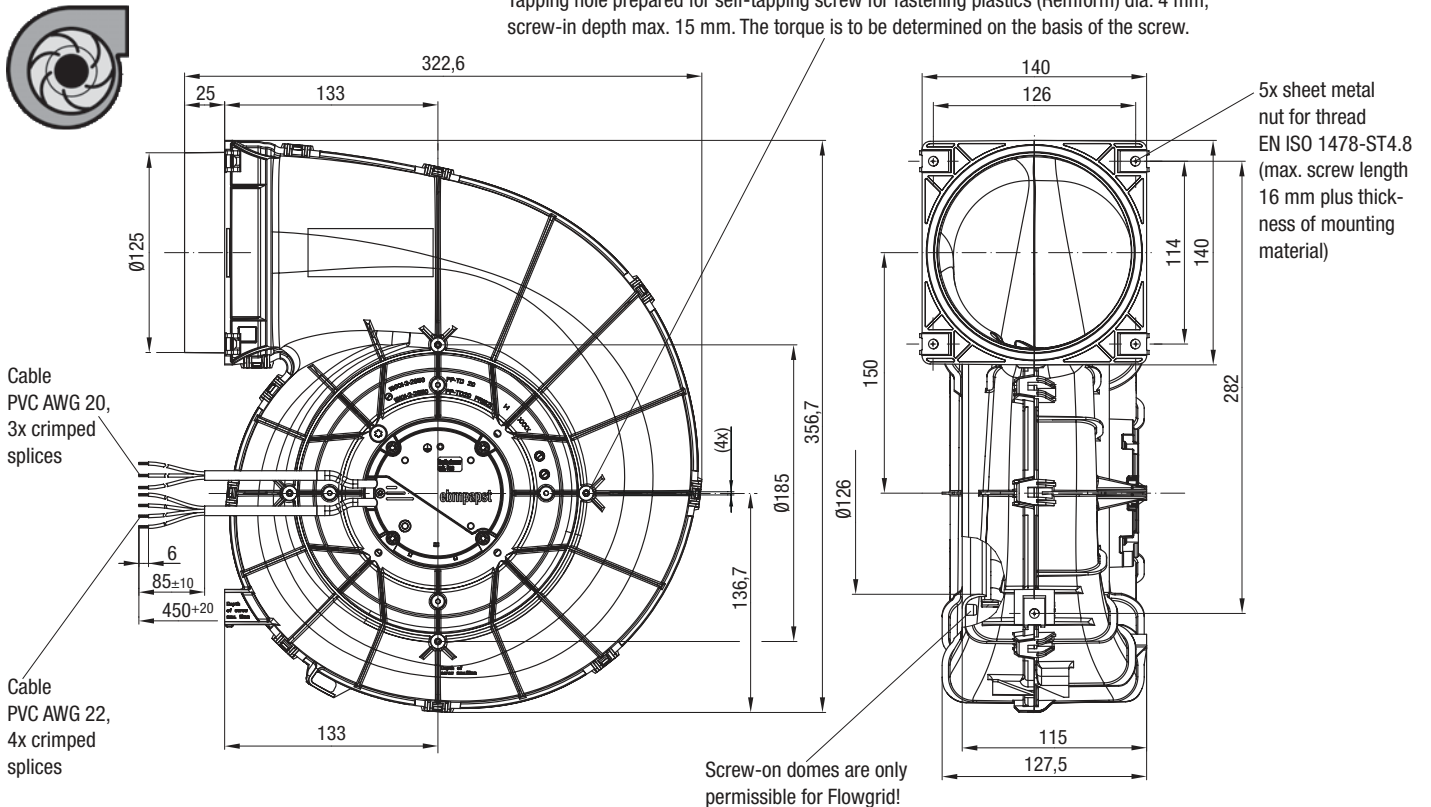

The cables shown refer to the 0-10 V/PWM design. For the illustration of the PWM design, see page 33.

EC centrifugal fans – RadiCal

backward curved, with housing, Ø 190



G3G 190-RD45-03 / G3G 190-RD45-05 / G3G 190-RD45-08 (Centrifugal fan with housing) / Speed-controlled, 170 W - Electronics

Tapping hole prepared for self-tapping screw for fastening plastics (Remform) dia. 4 mm, screw-in depth max. 15 mm. The torque is to be determined on the basis of the screw.

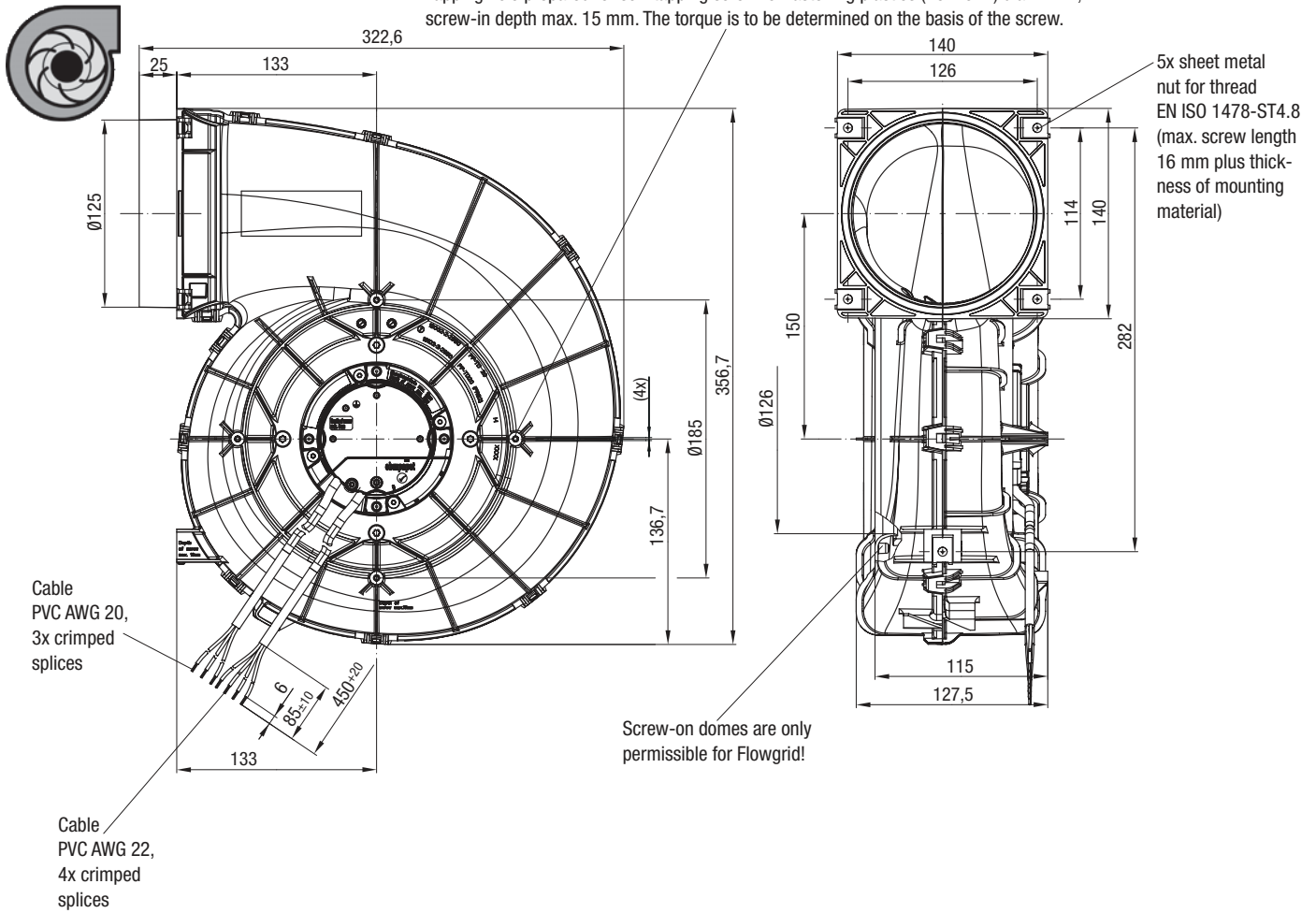

The cables shown refer to the 0-10 V/PWM design. For the illustration of the PWM respectively the MODBUS-RTU design, see page 33.

EC centrifugal fans – RadiCal

backward curved, with housing, Ø 190



G3G 190-RP03-04 (Centrifugal fan with housing) / Sensor-controlled, 85 W - Electronics

Tapping hole prepared for self-tapping screw for fastening plastics (Remform) dia. 4 mm, screw-in depth max. 15 mm. The torque is to be determined on the basis of the screw.

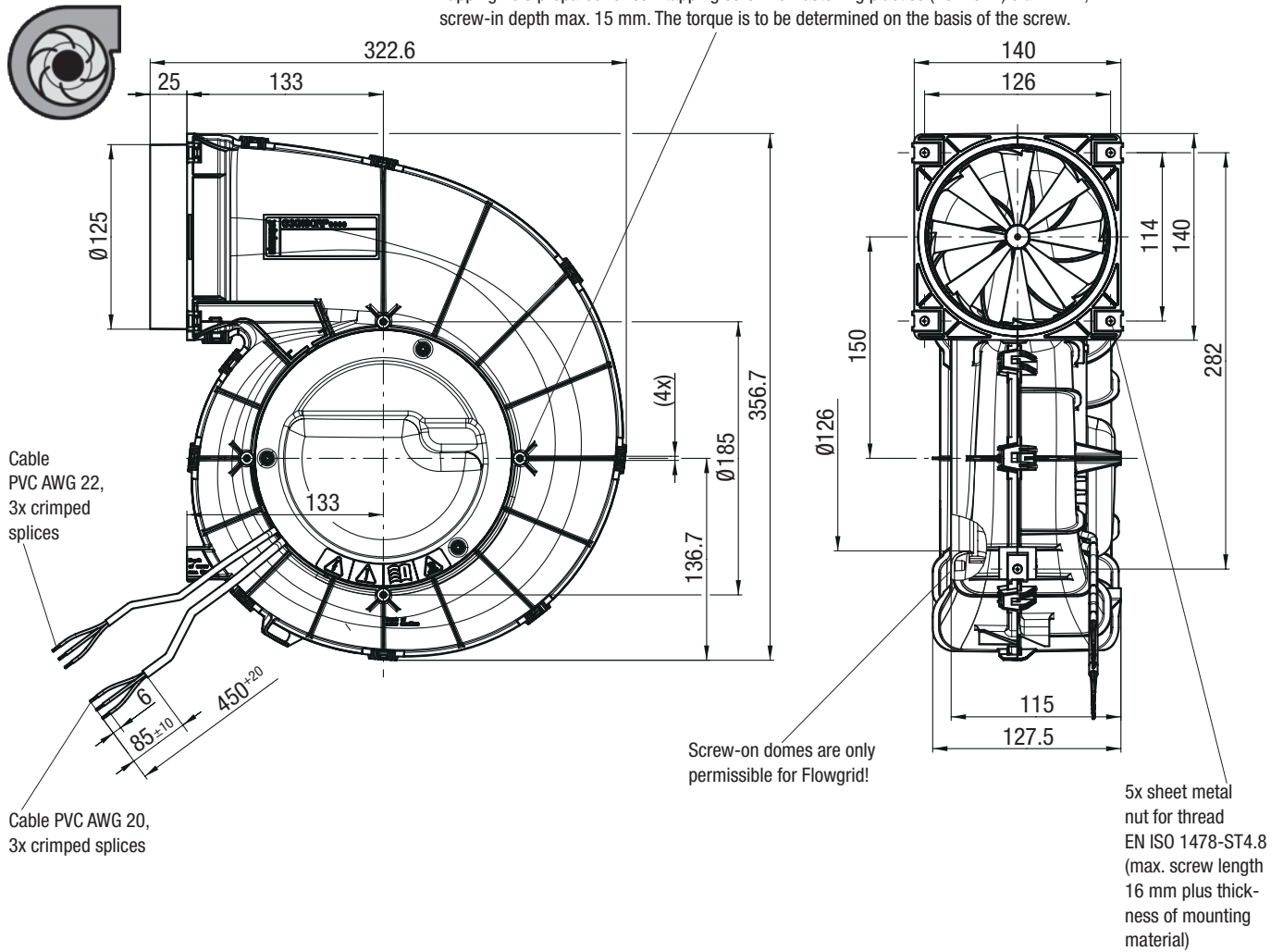

EC centrifugal fans – RadiCal

backward curved, with housing, Ø 190



G3G 190-RQ45-04 (Centrifugal fan with housing) / Sensor-controlled, 170 W - Electronics

Tapping hole prepared for self-tapping screw for fastening plastics (Remform) dia. 4 mm, screw-in depth max. 15 mm. The torque is to be determined on the basis of the screw.

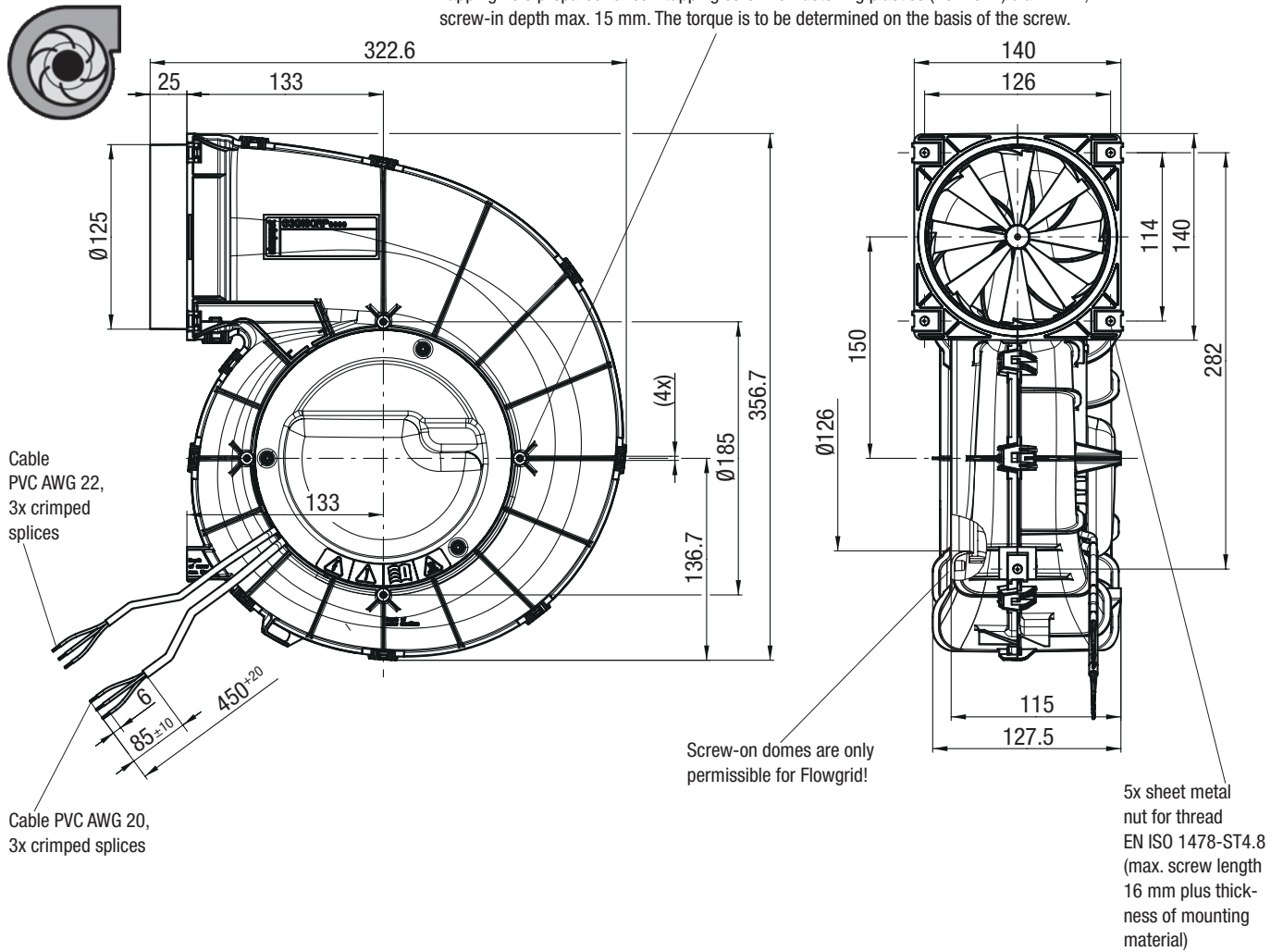

EC centrifugal fans – RadiCal

backward curved, Ø 220



- **Material:** Housing: Plastic
Impeller: Plastic
Rotor: Thick-film passivated
Electronics housing: Die-cast aluminium
- **Number of blades:** 7
- **Direction of rotation:** Clockwise viewed toward rotor
- **Degree of protection:** IP 54
- **Insulation class:** "B"
- **Installation position:** Any
- **Condensation drainage holes:** None, open rotor
- **Mode:** Continuous operation (S1)
- **Mounting:** Maintenance-free ball bearings

Nominal data

| Type | Motor | Curve | Nominal voltage range | Frequency | Speed ⁽¹⁾ | Max. Input power ⁽¹⁾ | Max. Input current ⁽¹⁾ | Perm. ambient temp. | Techn. features and connection diagram |
|---------|------------|-------|-----------------------|-----------|----------------------|---------------------------------|-----------------------------------|---------------------|--|
| Type | Motor | VAC | Hz | rpm | W | A | °C | | |
| *3G 220 | M3G 055-BI | Ⓐ | 1~200-240 | 50/60 | 2580 | 85 | 0,70 | -25..+60 | P. 145 / RC2) |
| *3G 220 | M3G 055-CF | Ⓑ | 1~200-240 | 50/60 | 3230 | 168 | 1,40 | -25..+50 | P. 145 / RC2) |
| *3G 220 | M3G 055-BI | Ⓒ | 1~200-240 | 50/60 | 2580 | 85 | 0,70 | -25..+60 | P. 146 / RC3) |
| *3G 220 | M3G 055-BI | Ⓓ | 1~200-240 | 50/60 | 2580 | 85 | 0,70 | -25..+60 | P. 154 / RC10) |
| *3G 220 | M3G 055-CF | Ⓔ | 1~200-240 | 50/60 | 2790 | 115 | 0,97 | -25..+50 | P. 144 / RC1) |
| *3G 220 | M3G 055-CF | Ⓕ | 1~200-240 | 50/60 | 2790 | 115 | 0,97 | -25..+50 | P. 154 / RC10) |
| *3G 220 | M3G 055-CF | Ⓖ | 1~200-240 | 50/60 | 3230 | 168 | 1,40 | -25..+50 | P. 152 / RC8) |
| *3G 220 | M3G 055-CF | Ⓗ | 1~200-240 | 50/60 | 3230 | 168 | 1,40 | -25..+50 | P. 154 / RC10) |
| *3G 220 | M3G 055-CF | Ⓘ | 1~200-240 | 50/60 | 3230 | 168 | 1,40 | -25..+50 | P. 155 / RC11) |

Subject to change

(1) Nominal data at operating point with maximum load and 230 VAC.

Curves: 2 Speed stages

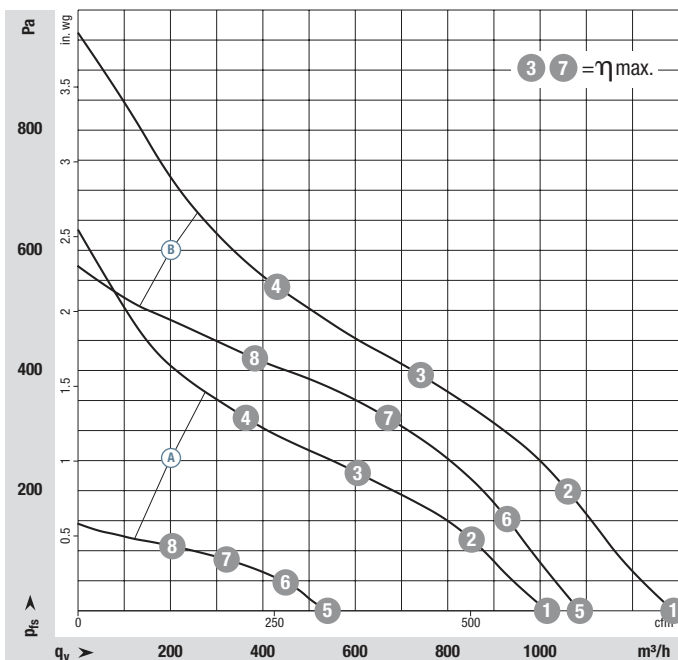

| | n rpm | P _{ed} W | I A | L _{WA} dB(A) |
|-----|-------|-------------------|------|-----------------------|
| Ⓐ ① | 2815 | 85 | 0,70 | 71 |
| Ⓐ ② | 2700 | 85 | 0,70 | 67 |
| Ⓐ ③ | 2580 | 85 | 0,70 | 65 |
| Ⓐ ④ | 2605 | 85 | 0,70 | 66 |
| Ⓐ ⑤ | 1550 | 17 | 0,19 | 57 |
| Ⓐ ⑥ | 1535 | 18 | 0,20 | 54 |
| Ⓐ ⑦ | 1510 | 19 | 0,21 | 51 |
| Ⓐ ⑧ | 1515 | 19 | 0,20 | 52 |
| Ⓑ ① | 3540 | 168 | 1,40 | 78 |
| Ⓑ ② | 3370 | 168 | 1,40 | 73 |
| Ⓑ ③ | 3230 | 168 | 1,40 | 70 |
| Ⓑ ④ | 3310 | 168 | 1,40 | 74 |
| Ⓑ ⑤ | 3000 | 100 | 0,85 | 73 |
| Ⓑ ⑥ | 2955 | 110 | 0,95 | 69 |
| Ⓑ ⑦ | 2900 | 120 | 1,00 | 67 |
| Ⓑ ⑧ | 2930 | 115 | 0,97 | 71 |

Air performance measured according to: ISO 5801, installation category A, with ebm-papst inlet ring without contact protection. Intake-side sound level: L_{WA} according to ISO 13347, L_{pA} measured at 1 m distance from fan axis. The values given are only applicable under the specified measuring conditions and may differ depending on the installation conditions. In the event of deviation from the standard configuration, the parameters must be checked in installed condition. See Page 162 ff. for detailed information.

- **Technical features:** See connection diagram P. 144 ff.
- **EMC:** Interference emission according to EN 61000-6-3
Immunity to interference according to EN 61000-6-2
Circuit feedback according to EN 61000-3-2/3
- **Touch current:** < 3,5 mA according to IEC 60990 (measuring circuit Fig. 4)
- **Cable exit:** Variable
- **Protection class:** I (with customer connection of protective earth)
- **Conformity with standards:** EN 60335-1, CE
- **Approvals:** VDE, UL, CSA, CCC, EAC on request
- **Efficiency:** Ecodesign EU regulation EU 327/2011

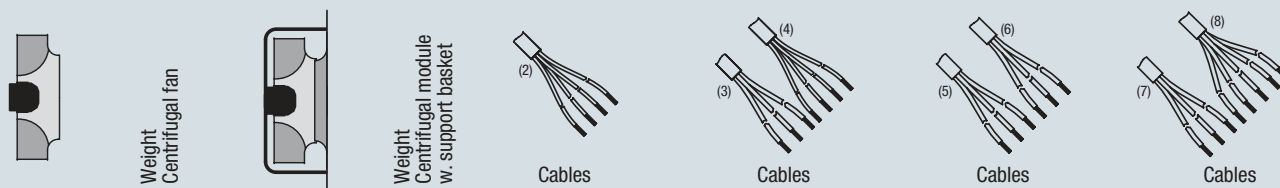

| Centrifugal fan | kg | Centrifugal module w. support basket | kg | 2 Speed stages | Speed-controlled 0-10 V / PWM | Speed-controlled PWM | Speed-controlled MODBUS-RTU |
|------------------|------|--------------------------------------|------|----------------|-------------------------------|----------------------|-----------------------------|
| R3G 220-RC05 -01 | 1,10 | K3G 220-RC05 -01 | 2,00 | X | | | |
| R3G 220-RD53 -01 | 1,50 | K3G 220-RD53 -01 | 2,40 | X | | | |
| R3G 220-RC05 -03 | 1,20 | K3G 220-RC05 -03 | 2,10 | | X | | |
| R3G 220-RC05 -05 | 1,20 | K3G 220-RC05 -05 | 2,10 | | | X | |
| R3G 220-RG19 -01 | 1,40 | K3G 220-RG19 -01 | 2,00 | | X | | |
| R3G 220-RG19 -05 | 1,40 | K3G 220-RG19 -05 | 2,00 | | | X | |
| R3G 220-RD53 -03 | 1,50 | K3G 220-RD53 -03 | 2,40 | | X | | |
| R3G 220-RD53 -05 | 1,50 | K3G 220-RD53 -05 | 2,40 | | | X | |
| R3G 220-RD53 -08 | 1,50 | K3G 220-RD53 -08 | 2,40 | | | | X |

(2) PVC AWG 20, 4x splices

(3) PVC AWG 20, 3x splices
(4) PVC AWG 22, 4x splices

(5) PVC AWG 20, 3x splices
(6) PVC AWG 22, 3x splices

(7) PVC AWG 20, 3x splices
(8) PVC AWG 22, 5x splices

Curves:
Speed-controlled
0-10 V / PWM
PWM
MODBUS-RTU

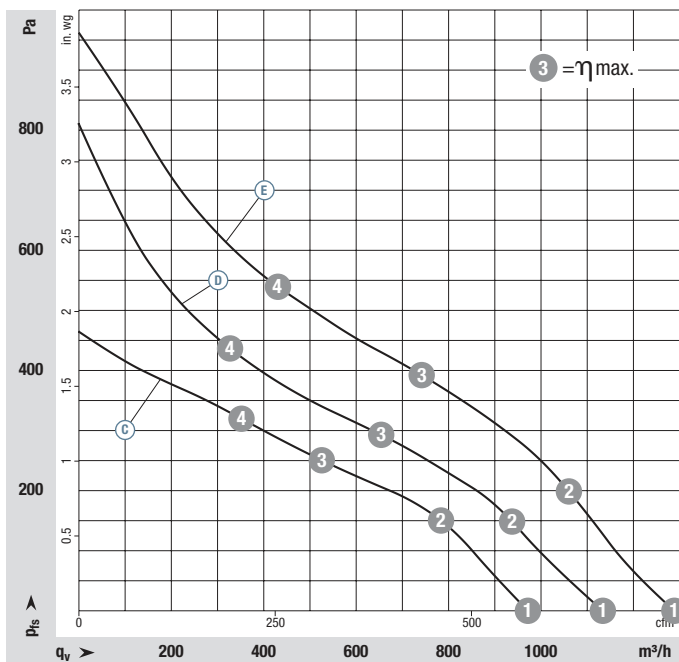

| | n rpm | P _{ed} W | I A | L _{wA} dB(A) |
|-----|-------|-------------------|------|-----------------------|
| Ⓒ 1 | 2695 | 78 | 0,69 | 71 |
| Ⓒ 2 | 2595 | 85 | 0,70 | 67 |
| Ⓒ 3 | 2580 | 85 | 0,70 | 65 |
| Ⓒ 4 | 2585 | 85 | 0,70 | 66 |
| Ⓓ 1 | 3085 | 115 | 0,97 | 74 |
| Ⓓ 2 | 2935 | 115 | 0,97 | 69 |
| Ⓓ 3 | 2790 | 115 | 0,97 | 66 |
| Ⓓ 4 | 2940 | 115 | 0,97 | 70 |
| Ⓔ 1 | 3540 | 168 | 1,40 | 78 |
| Ⓔ 2 | 3370 | 168 | 1,40 | 73 |
| Ⓔ 3 | 3230 | 168 | 1,40 | 70 |
| Ⓔ 4 | 3310 | 168 | 1,40 | 74 |

Air performance measured according to: ISO 5801, installation category A, with ebm-papst inlet ring without contact protection. Intake-side sound level: L_{wA} according to ISO 13347, L_{pA} measured at 1 m distance from fan axis. The values given are only applicable under the specified measuring conditions and may differ depending on the installation conditions. In the event of deviation from the standard configuration, the parameters must be checked in installed condition. See Page 162 ff. for detailed information.

EC centrifugal fans – RadiCal

backward curved, Ø 220, 2 Speed stages, 85 W - Electronics



R3G 220-RC05-01 (Centrifugal fan)

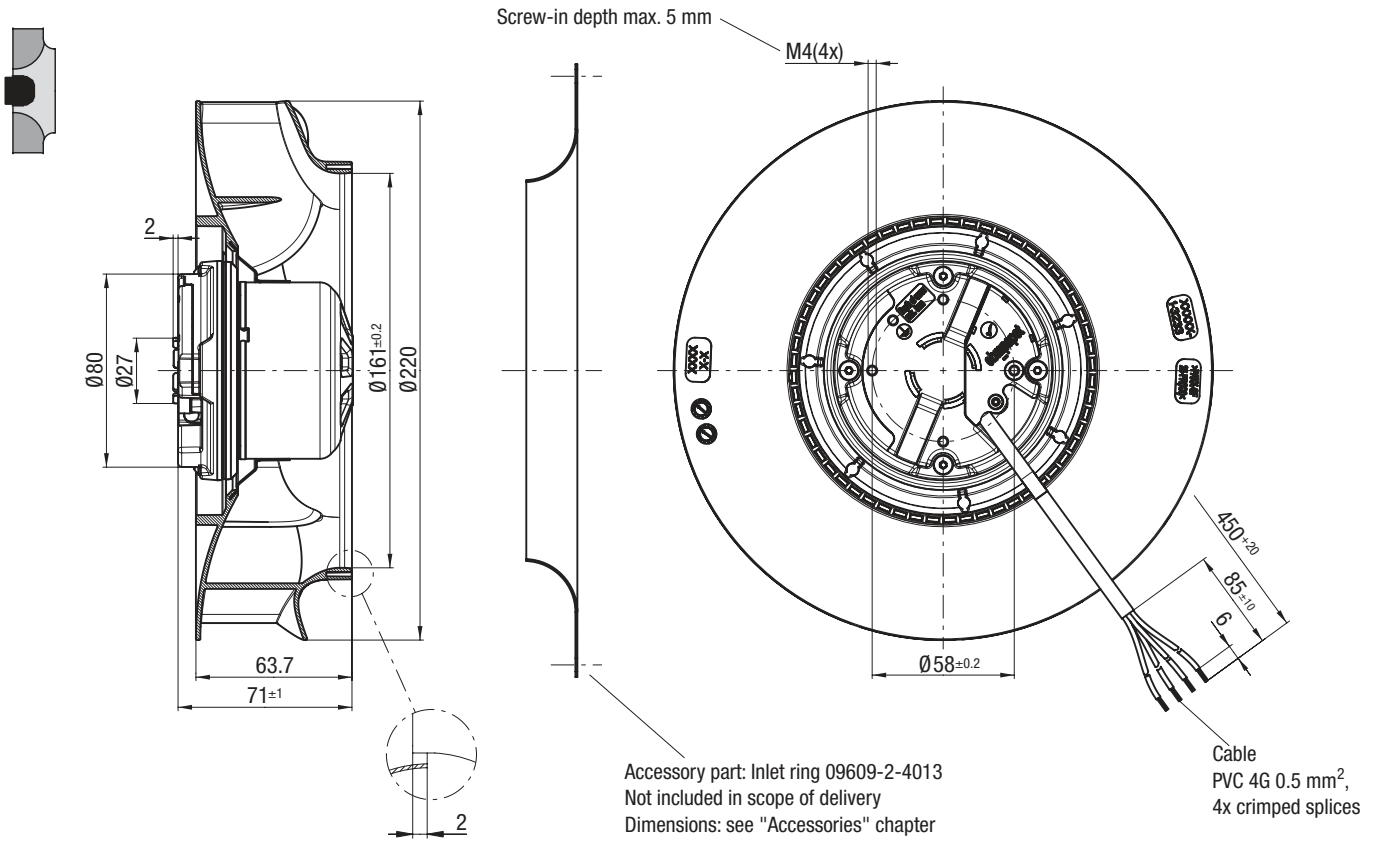

K3G 220-RC05-01 (Centrifugal module with support basket)

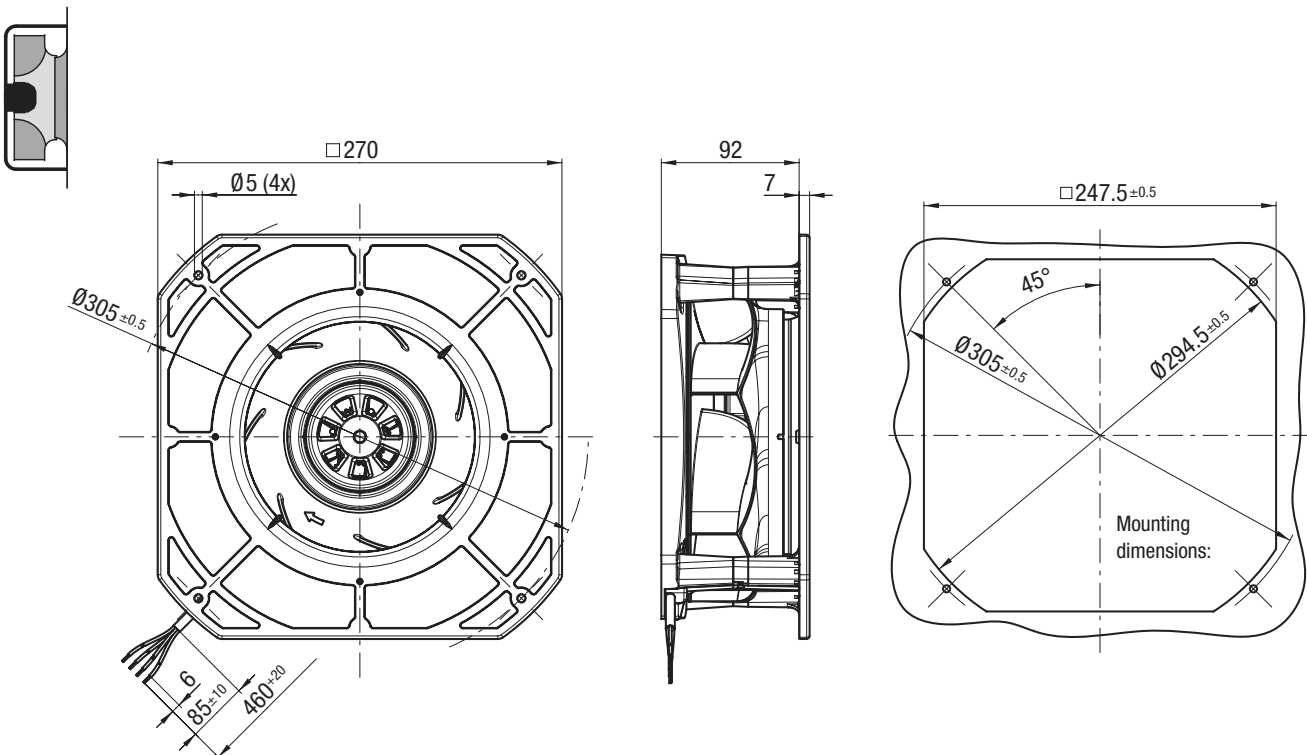

EC centrifugal fans – RadiCal

backward curved, Ø 220, 2 Speed stages, 170 W - Electronics



R3G 220-RD53-01 (Centrifugal fan)

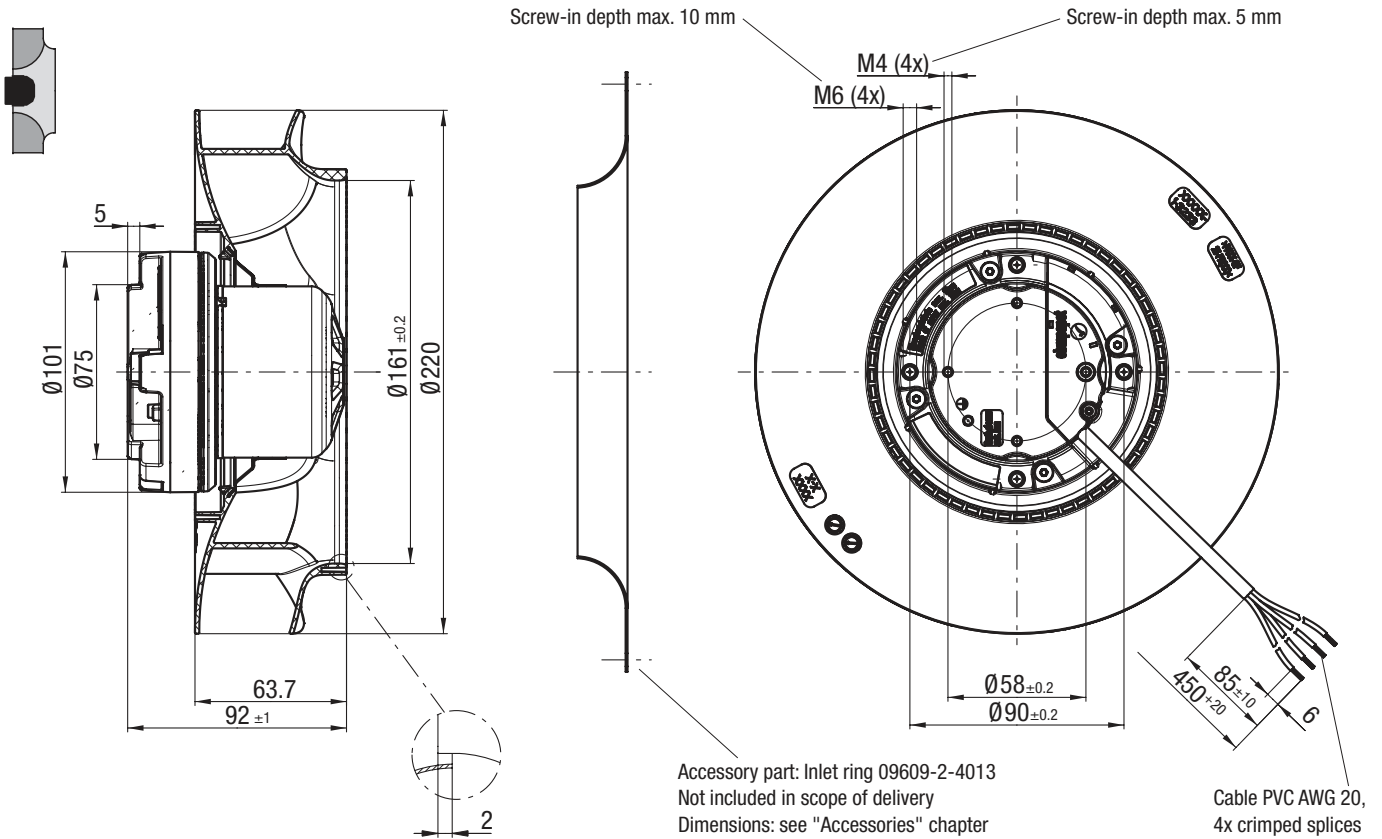

K3G 220-RD53-01 (Centrifugal module with support basket)

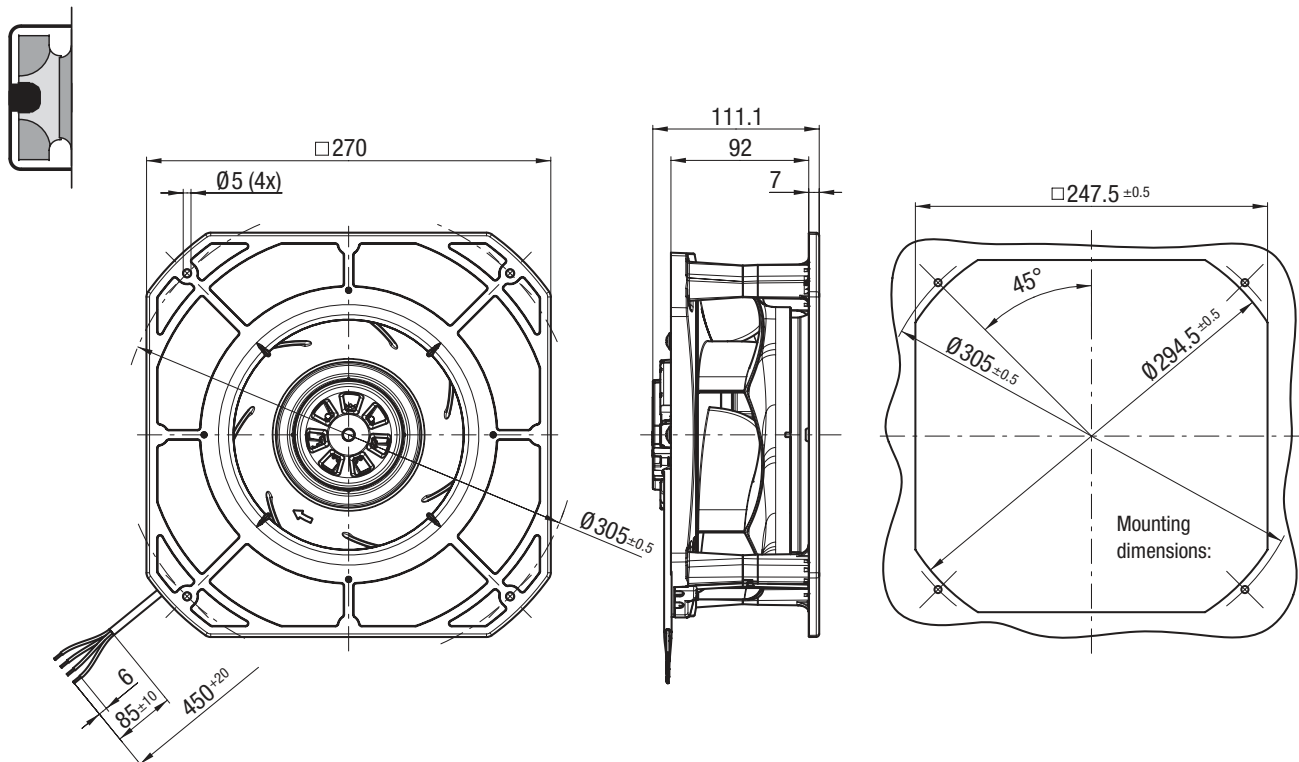

EC centrifugal fans – RadiCal

backward curved, Ø 220, Speed-controlled, 85 W - Electronics



R3G 220-RC05-03 / R3G 220-RC05-05 (Centrifugal fan)

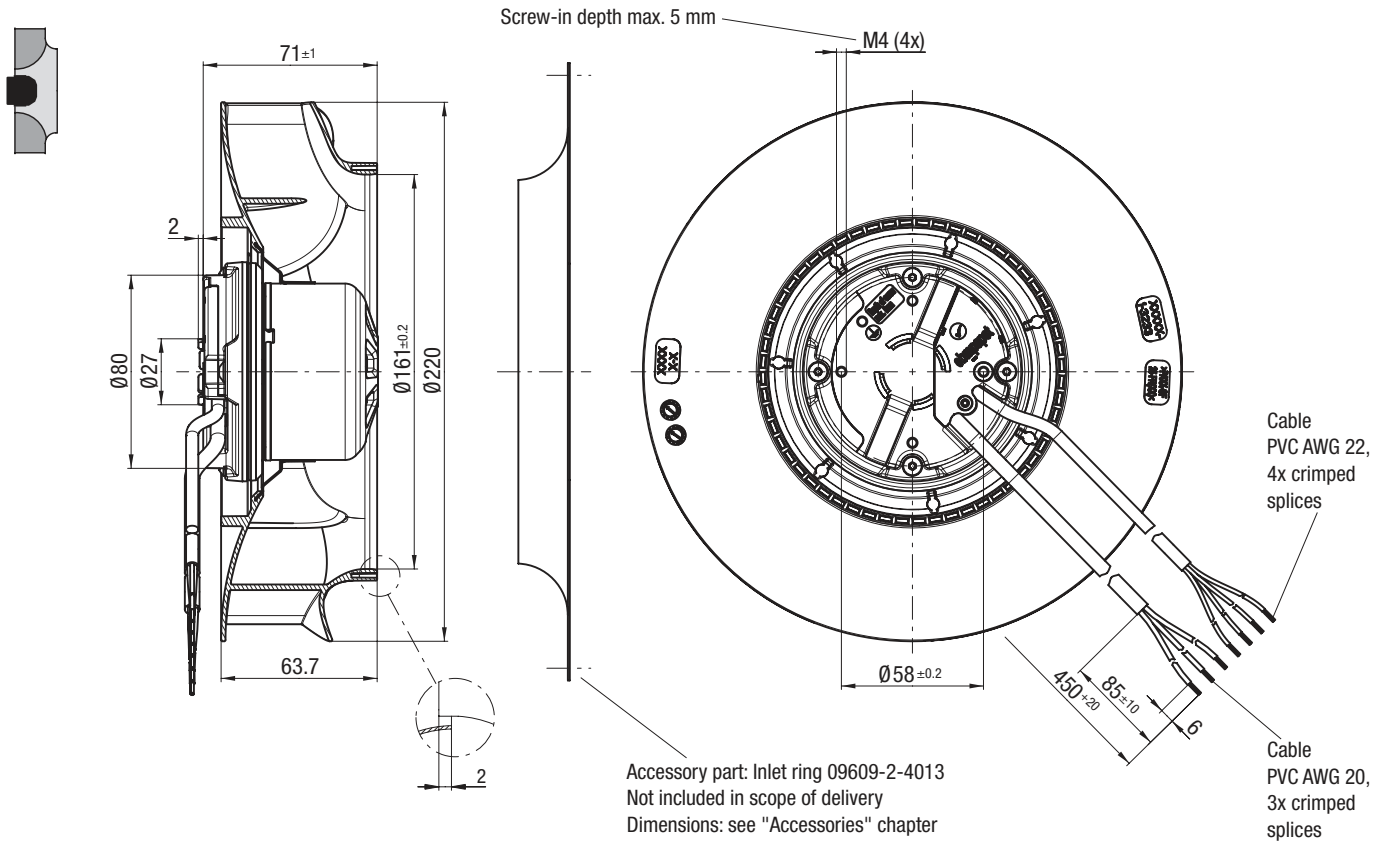

K3G 220-RC05-03 / K3G 220-RC05-05 (Centrifugal module with support basket)

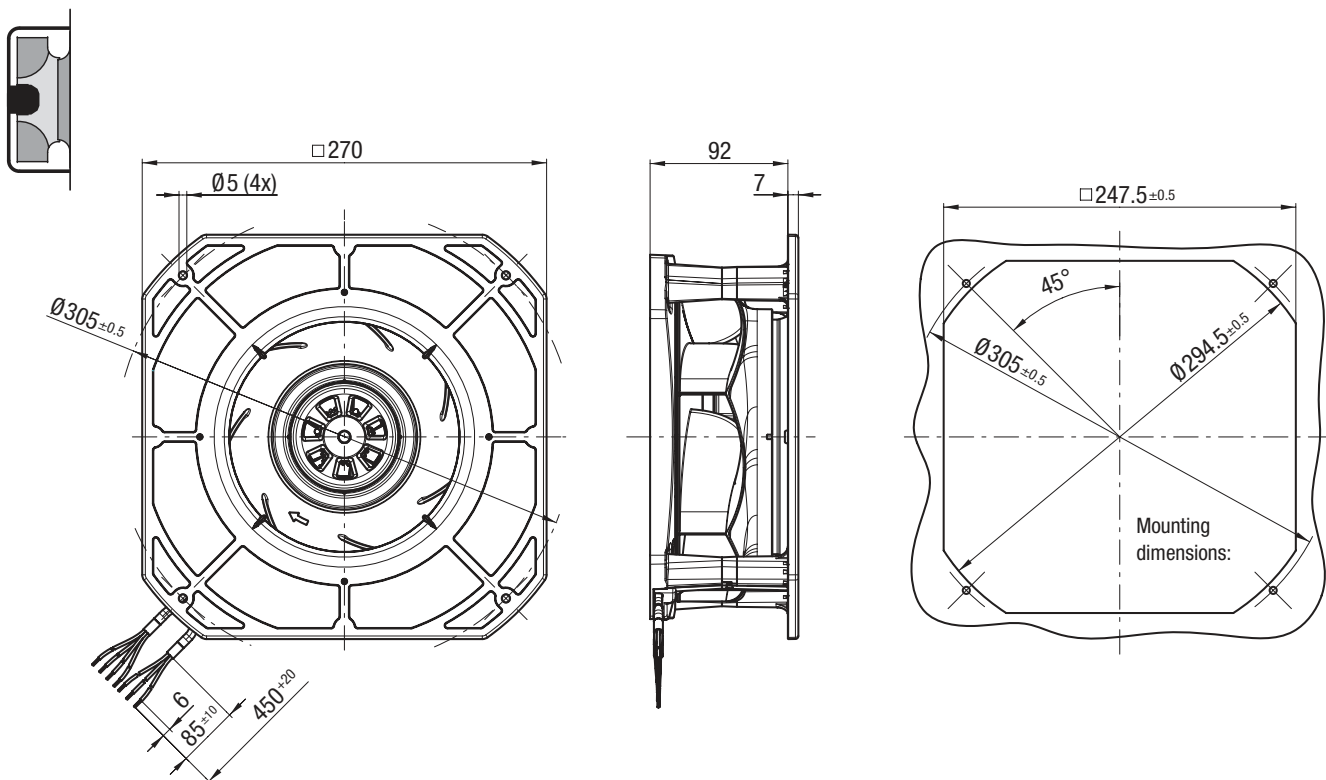

The R- and K-type cables shown refer to the 0-10 V/PWM design. For the illustration of the PWM design, see page 39.

EC centrifugal fans – RadiCal

backward curved, Ø 220, Speed-controlled, 115 W - Electronics



R3G 220-RG19-01 / R3G 220-RG19-05 (Centrifugal fan)

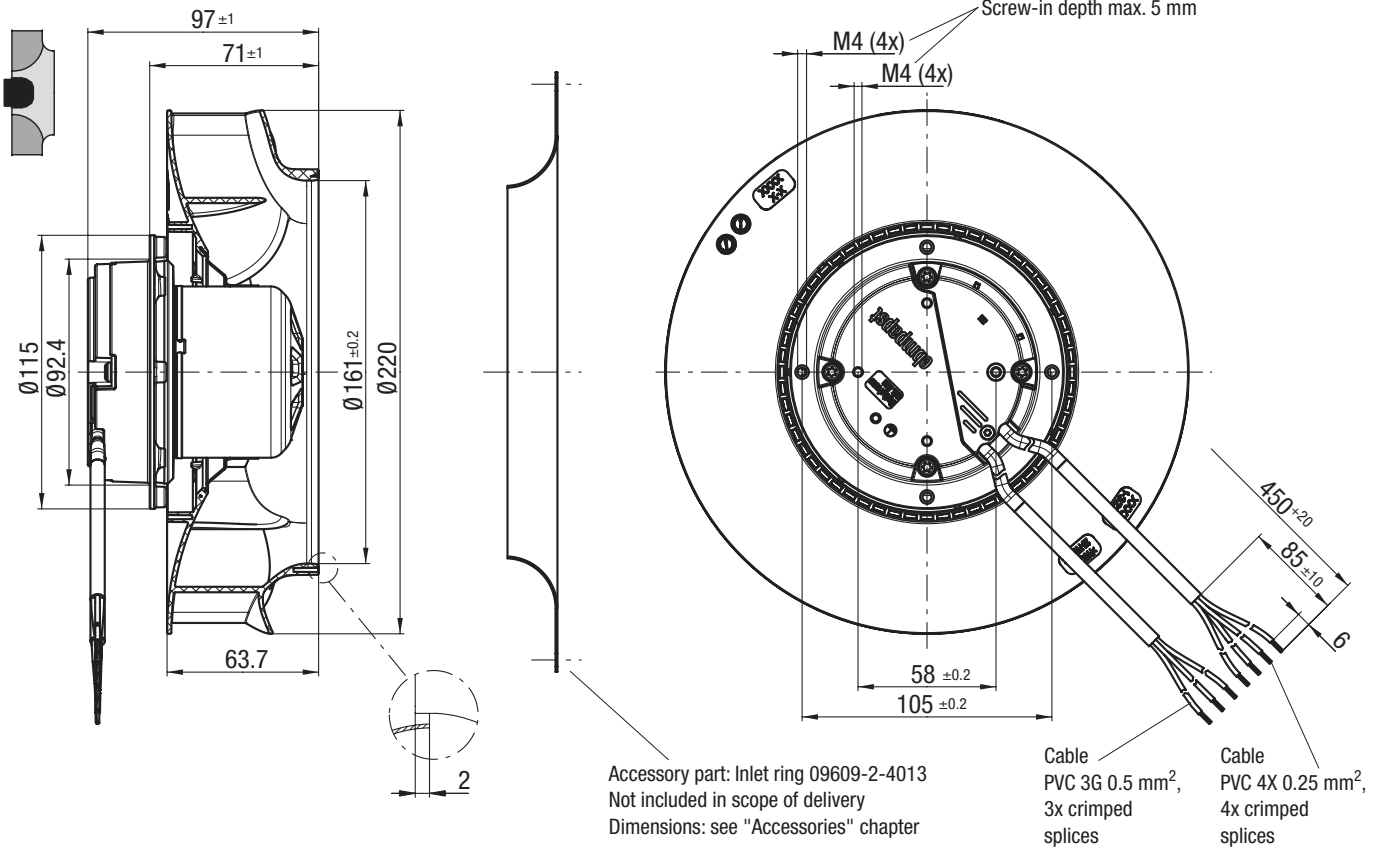

K3G 220-RG19-01 / K3G 220-RG19-05 (Centrifugal module with support basket)

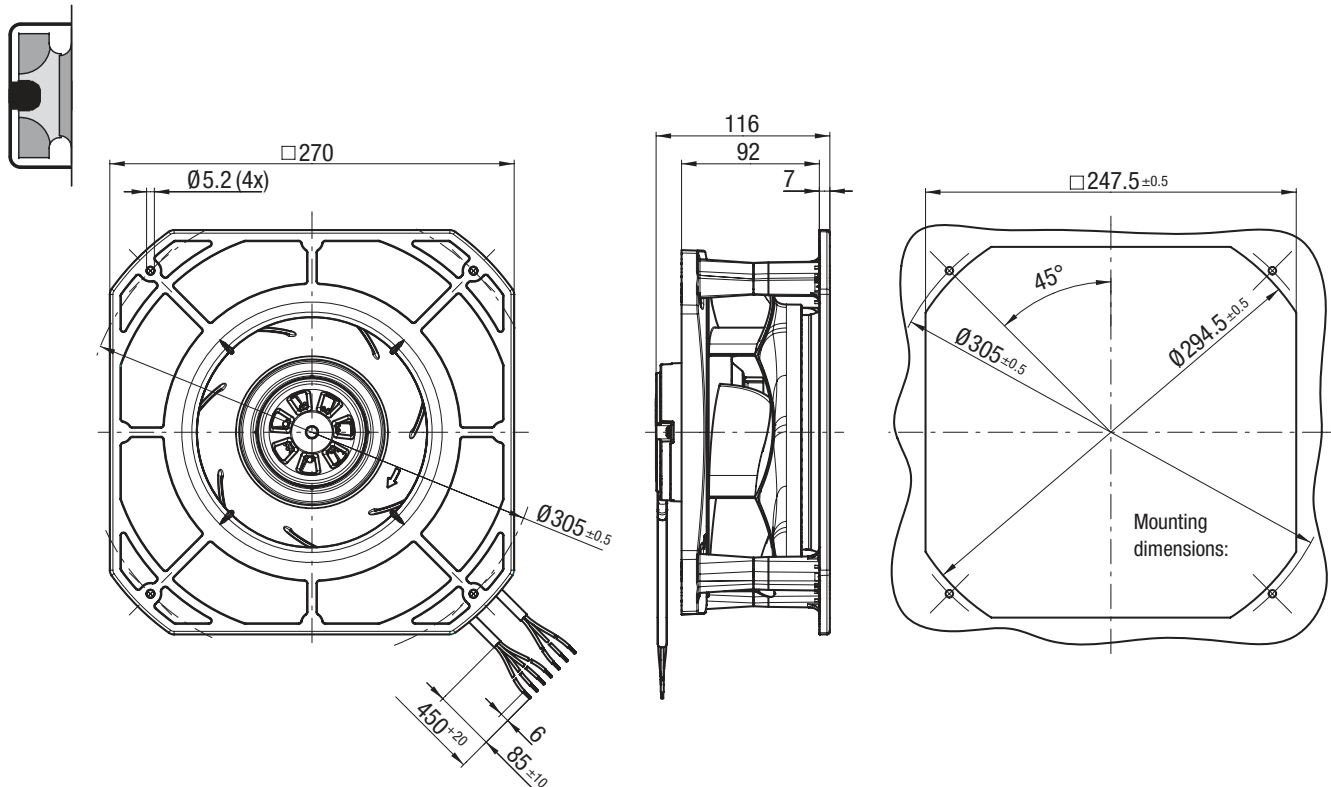

The R- and K-type cables shown refer to the 0-10 V/PWM design. For the illustration of the PWM design, see page 39.

EC centrifugal fans – RadiCal

backward curved, Ø 220, Speed-controlled, 170 W - Electronics



R3G 220-RD53-03 / R3G 220-RD53-05 / R3G 220-RD53-08 (Centrifugal fan)

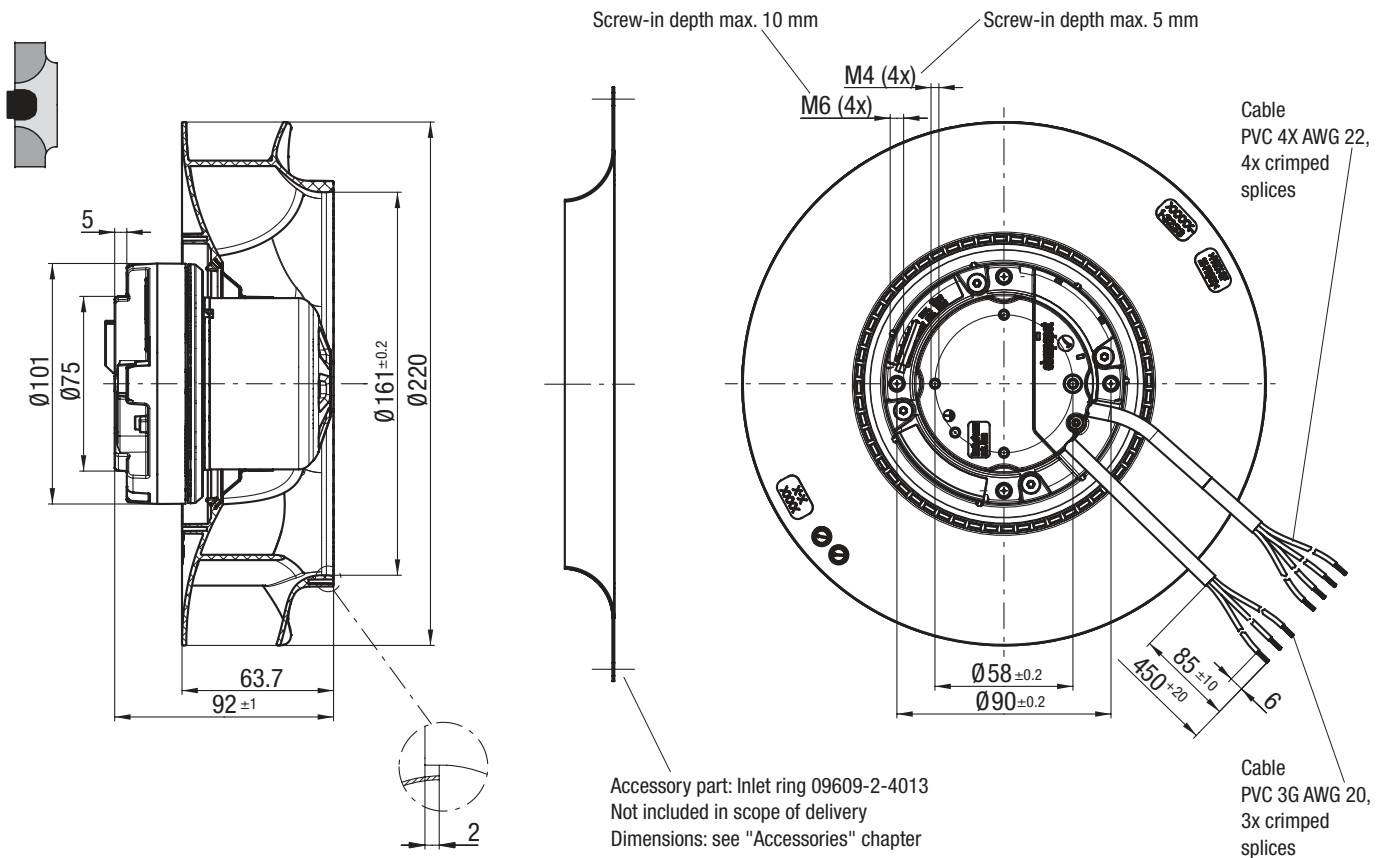

K3G 220-RD53-03 / K3G 220-RD53-05 / K3G 220-RD53-08 (Centrifugal module with support basket)

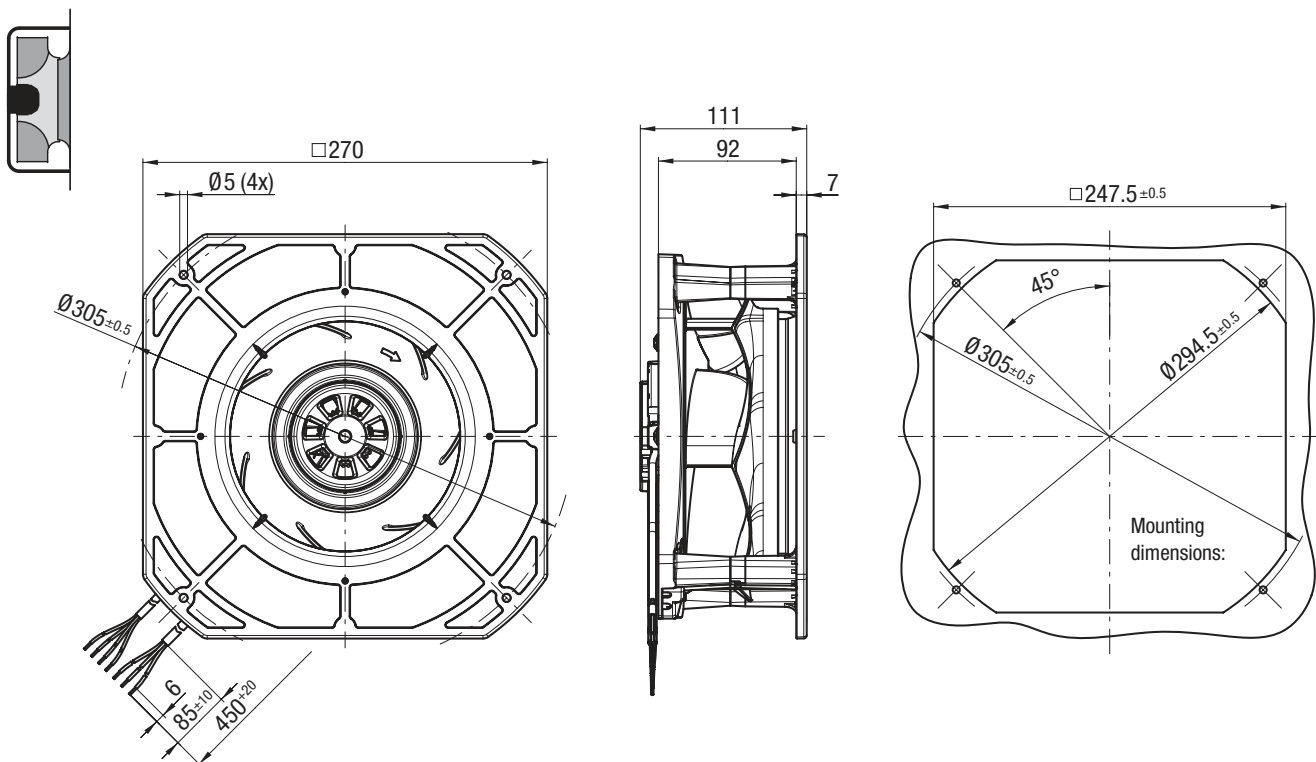

The R- and K-type cables shown refer to the 0-10 V/PWM design. For the illustration of the PWM respectively the MODBUS-RTU design, see page 39.

EC centrifugal fans – RadiCal

backward curved, Ø 225



- **Material:** Housing: Plastic
Impeller: Plastic
Rotor: Thick-film passivated
Electronics housing: Die-cast aluminium
- **Number of blades:** 7
- **Direction of rotation:** Clockwise viewed toward rotor
- **Degree of protection:** IP 54
- **Insulation class:** "B"
- **Installation position:** Any
- **Condensation drainage holes:** None, open rotor
- **Mode:** Continuous operation (S1)
- **Mounting:** Maintenance-free ball bearings

Nominal data

| Type | Motor | Curve | Nominal voltage range | Frequency | Speed ⁽¹⁾ | Max. Input power ⁽¹⁾ | Max. Input current ⁽¹⁾ | Perm. ambient temp. | Techn. features and connection diagram |
|---------|------------|-------|-----------------------|-----------|----------------------|---------------------------------|-----------------------------------|---------------------|--|
| Type | Motor | VAC | Hz | rpm | W | A | °C | | |
| *3G 225 | M3G 055-CF | Ⓐ | 1~200-240 | 50/60 | 2200 | 82 | 0,70 | -25..+60 | P. 145 / RC2) |
| *3G 225 | M3G 055-DF | Ⓑ | 1~200-240 | 50/60 | 2860 | 170 | 1,40 | -25..+60 | P. 145 / RC2) |
| *3G 225 | M3G 055-CF | Ⓒ | 1~200-240 | 50/60 | 2200 | 82 | 0,70 | -25..+60 | P. 146 / RC3) |
| *3G 225 | M3G 055-CF | Ⓓ | 1~200-240 | 50/60 | 2200 | 82 | 0,70 | -25..+60 | P. 154 / RC10) |
| *3G 225 | M3G 055-CF | Ⓔ | 1~200-240 | 50/60 | 2440 | 107 | 0,90 | -25..+60 | P. 144 / RC1) |
| *3G 225 | M3G 055-CF | Ⓕ | 1~200-240 | 50/60 | 2440 | 107 | 0,90 | -25..+60 | P. 154 / RC10) |
| *3G 225 | M3G 055-DF | Ⓖ | 1~200-240 | 50/60 | 2860 | 170 | 1,40 | -25..+60 | P. 152 / RC8) |
| *3G 225 | M3G 055-DF | Ⓗ | 1~200-240 | 50/60 | 2860 | 170 | 1,40 | -25..+60 | P. 154 / RC10) |
| *3G 225 | M3G 055-DF | Ⓘ | 1~200-240 | 50/60 | 2860 | 170 | 1,40 | -25..+60 | P. 155 / RC11) |

Subject to change

(1) Nominal data at operating point with maximum load and 230 VAC.

Curves: 2 Speed stages

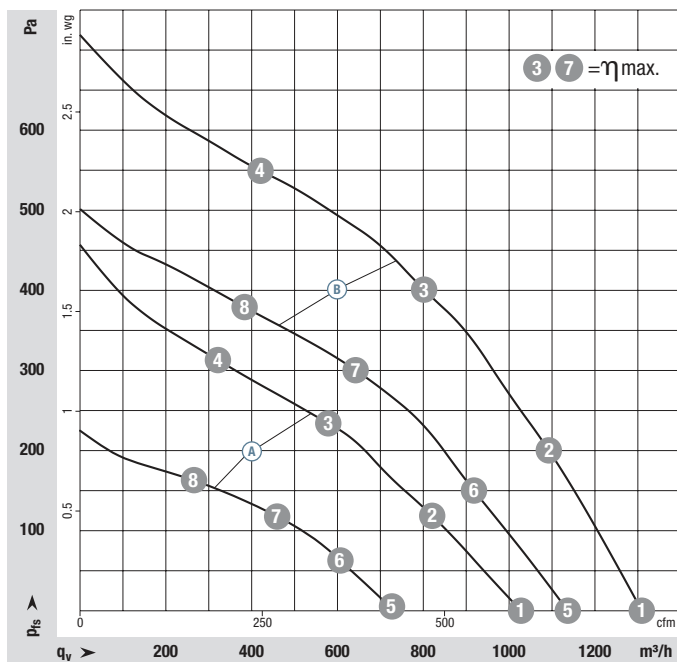

| | n rpm | P _{ed} W | I A | L _{wA} dB(A) |
|-----|-------|-------------------|------|-----------------------|
| Ⓐ ① | 2285 | 70 | 0,62 | 69 |
| Ⓐ ② | 2165 | 77 | 0,66 | 64 |
| Ⓐ ③ | 2200 | 82 | 0,70 | 60 |
| Ⓐ ④ | 2250 | 71 | 0,61 | 67 |
| Ⓐ ⑤ | 1640 | 27 | 0,28 | 61 |
| Ⓐ ⑥ | 1580 | 31 | 0,31 | 58 |
| Ⓐ ⑦ | 1585 | 31 | 0,32 | 53 |
| Ⓐ ⑧ | 1640 | 28 | 0,29 | 58 |
| Ⓑ ① | 3030 | 151 | 1,25 | 78 |
| Ⓑ ② | 2910 | 168 | 1,40 | 74 |
| Ⓑ ③ | 2860 | 170 | 1,40 | 68 |
| Ⓑ ④ | 2970 | 157 | 1,35 | 73 |
| Ⓑ ⑤ | 2550 | 91 | 0,83 | 74 |
| Ⓑ ⑥ | 2495 | 104 | 0,94 | 70 |
| Ⓑ ⑦ | 2490 | 105 | 0,93 | 65 |
| Ⓑ ⑧ | 2525 | 97 | 0,89 | 69 |

Air performance measured according to: ISO 5801, installation category A, with ebm-papst inlet ring without contact protection. Intake-side sound level: L_{wA} according to ISO 13347, L_{pA} measured at 1 m distance from fan axis. The values given are only applicable under the specified measuring conditions and may differ depending on the installation conditions. In the event of deviation from the standard configuration, the parameters must be checked in installed condition. See Page 162 ff. for detailed information.

- **Technical features:** See connection diagram P. 144 ff.
- **EMC:** Interference emission according to EN 61000-6-3
Immunity to interference according to EN 61000-6-2
Circuit feedback according to EN 61000-3-2/3
- **Touch current:** < 3,5 mA according to IEC 60990 (measuring circuit Fig. 4)
- **Cable exit:** Variable
- **Protection class:** I (with customer connection of protective earth)
- **Conformity with standards:** EN 60335-1, CE
- **Approvals:** VDE, UL, CSA, CCC, EAC on request
- **Efficiency:** Ecodesign EU regulation EU 327/2011

| Centrifugal fan | kg | Centrifugal module w. support basket | kg | 2 Speed stages | Speed-controlled 0-10 V / PWM | Speed-controlled PWM | Speed-controlled MODBUS-RTU |
|------------------|------|--------------------------------------|------|----------------|-------------------------------|----------------------|-----------------------------|
| R3G 225-RD05 -01 | 1,40 | K3G 225-RD05 -01 | 2,00 | X | | | |
| R3G 225-RE07 -01 | 1,60 | K3G 225-RE07 -01 | 2,20 | X | | | |
| R3G 225-RD05 -03 | 1,40 | K3G 225-RD05 -03 | 2,00 | | X | | |
| R3G 225-RD05 -05 | 1,40 | K3G 225-RD05 -05 | 2,00 | | | X | |
| R3G 225-RH19 -01 | 1,50 | K3G 225-RH19 -01 | 2,10 | | X | | |
| R3G 225-RH19 -05 | 1,50 | K3G 225-RH19 -05 | 2,10 | | | X | |
| R3G 225-RE07 -03 | 1,60 | K3G 225-RE07 -03 | 2,20 | | X | | |
| R3G 225-RE07 -05 | 1,60 | K3G 225-RE07 -05 | 2,20 | | | X | |
| R3G 225-RE07 -22 | 1,60 | K3G 225-RE07 -22 | 2,20 | | | | X |

(2) PVC AWG 20, 4x splices (3) PVC AWG 20, 3x splices (4) PVC AWG 22, 4x splices (5) PVC AWG 20, 3x splices (6) PVC AWG 22, 3x splices (7) PVC AWG 20, 3x splices (8) PVC AWG 22, 5x splices

Curves:
Speed-controlled
0-10 V / PWM
PWM
MODBUS-RTU

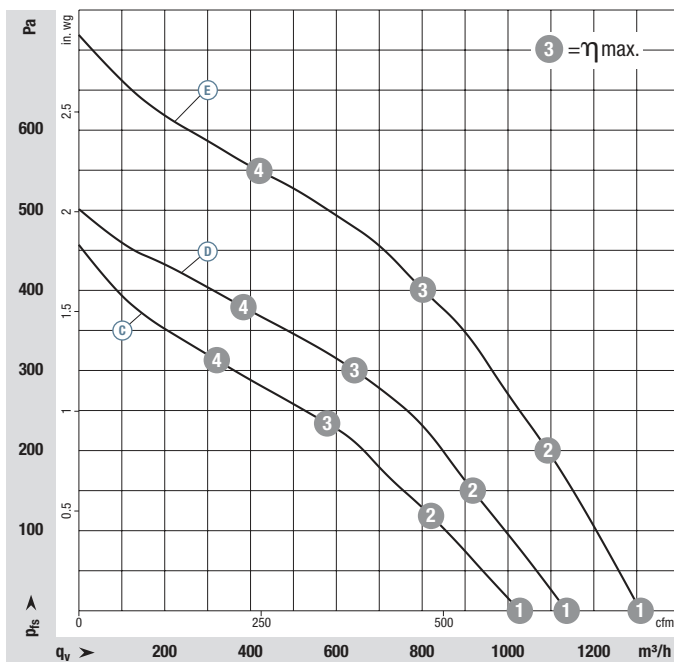

| | n rpm | P _{ed} W | I A | L _{wA} dB(A) |
|-----|-------|-------------------|------|-----------------------|
| ⓐ 1 | 2285 | 70 | 0,62 | 69 |
| ⓐ 2 | 2160 | 79 | 0,66 | 64 |
| ⓐ 3 | 2200 | 82 | 0,70 | 60 |
| ⓐ 4 | 2265 | 70 | 0,60 | 68 |
| ⓓ 1 | 2570 | 94 | 0,81 | 73 |
| ⓓ 2 | 2475 | 107 | 0,90 | 69 |
| ⓓ 3 | 2440 | 107 | 0,90 | 65 |
| ⓓ 4 | 2530 | 99 | 0,85 | 69 |
| ⓔ 1 | 2965 | 147 | 1,17 | 78 |
| ⓔ 2 | 2880 | 170 | 1,40 | 74 |
| ⓔ 3 | 2860 | 170 | 1,40 | 68 |
| ⓔ 4 | 2970 | 149 | 1,22 | 74 |

Air performance measured according to: ISO 5801, installation category A, with ebm-papst inlet ring without contact protection. Intake-side sound level: L_{wA} according to ISO 13347, L_{pA} measured at 1 m distance from fan axis. The values given are only applicable under the specified measuring conditions and may differ depending on the installation conditions. In the event of deviation from the standard configuration, the parameters must be checked in installed condition. See Page 162 ff. for detailed information.

EC centrifugal fans – RadiCal

backward curved, Ø 225, 2 Speed stages, 85 W - Electronics



R3G 225-RD05-01 (Centrifugal fan)

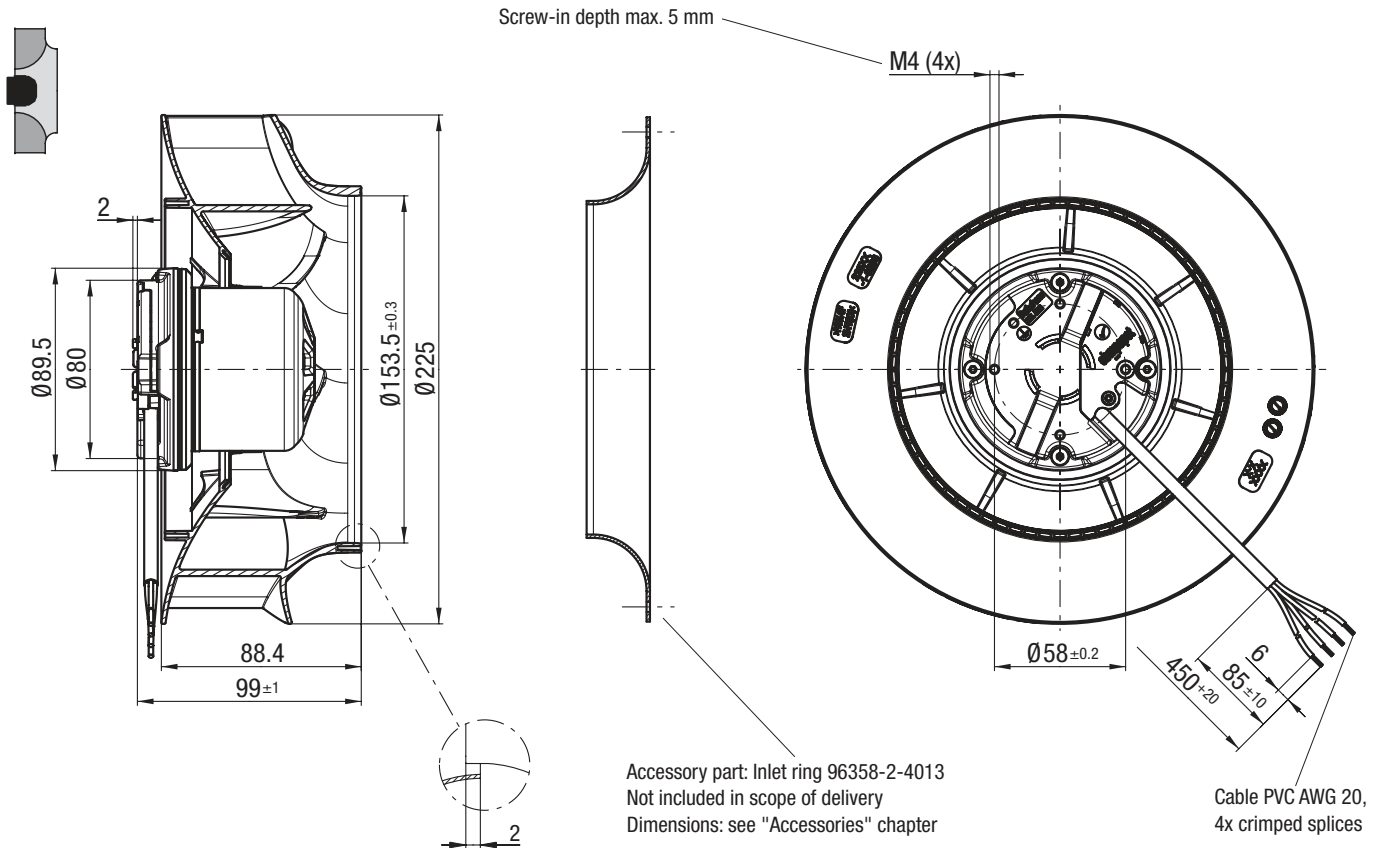

K3G 225-RD05-01 (Centrifugal module with support basket)

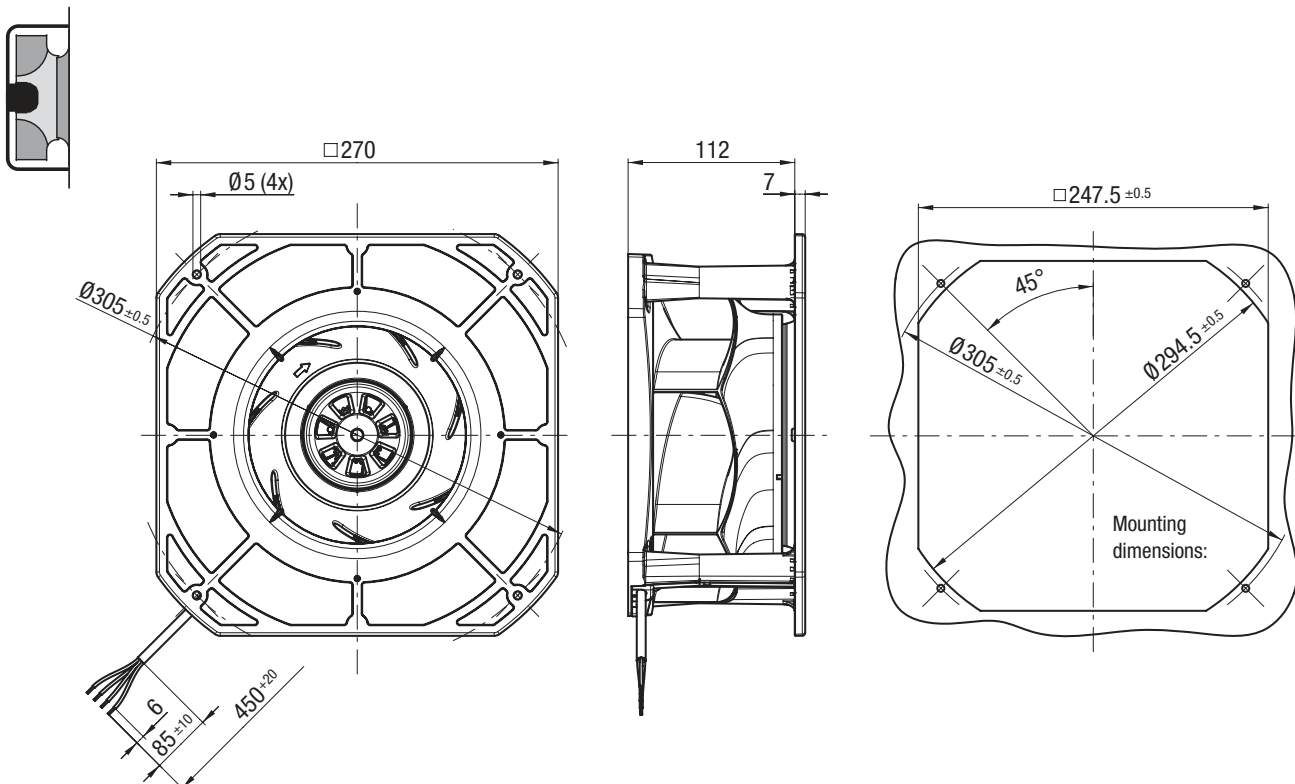

EC centrifugal fans – RadiCal

backward curved, Ø 225, 2 Speed stages, 170 W - Electronics



R3G 225-RE07-01 (Centrifugal fan)

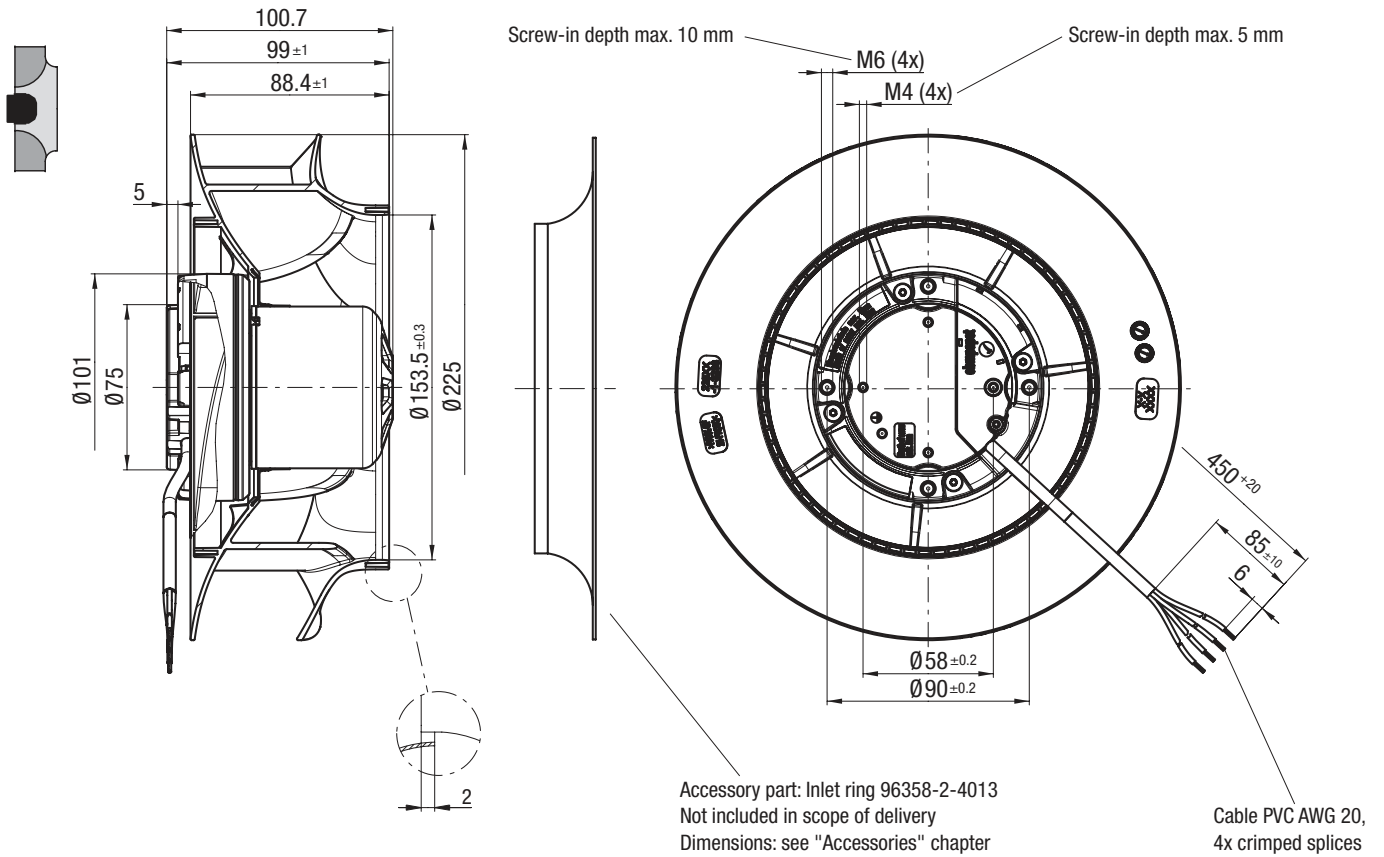

K3G 225-RE07-01 (Centrifugal module with support basket)

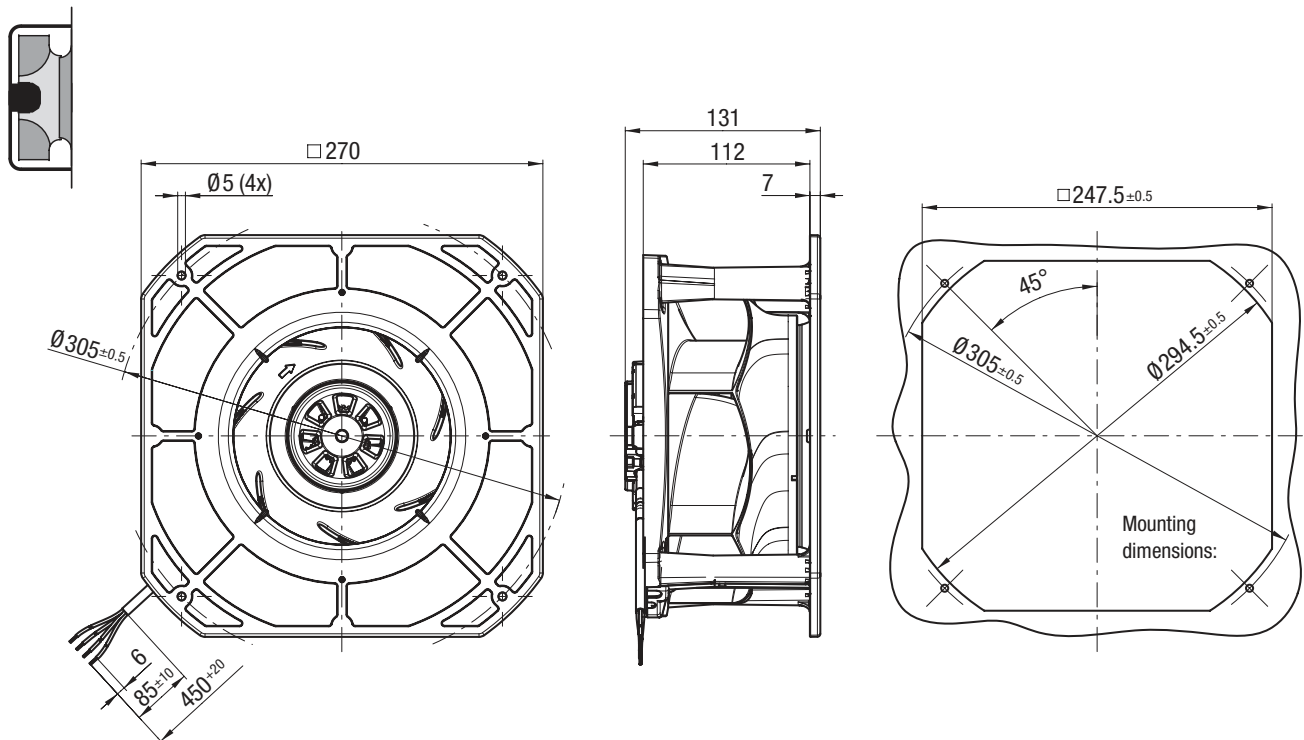

EC centrifugal fans – RadiCal

backward curved, Ø 225, Speed-controlled, 85 W - Electronics



R3G 225-RD05-03 / R3G 225-RD05-05 (Centrifugal fan)

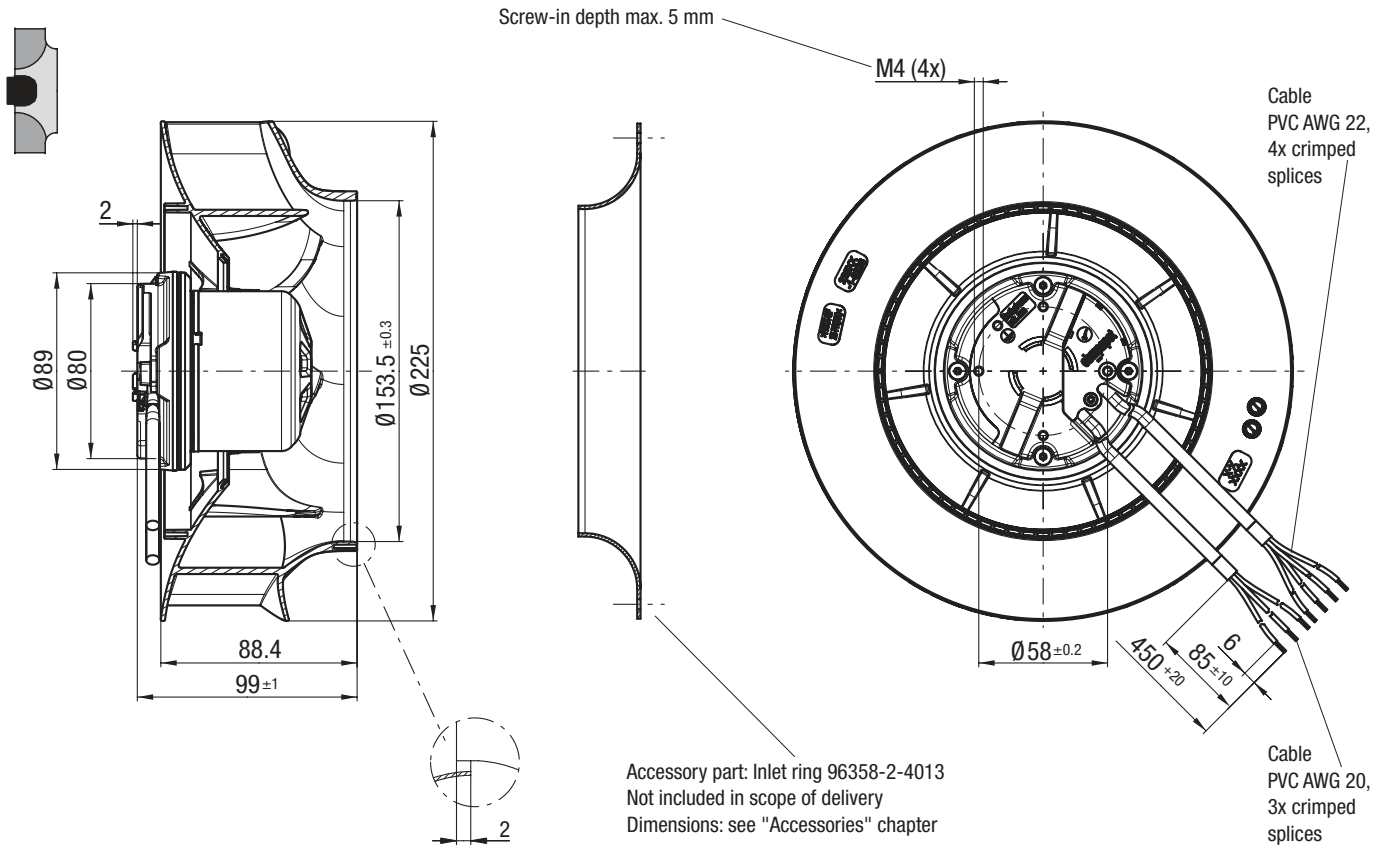

K3G 225-RD05-03 / K3G 225-RD05-05 (Centrifugal module with support basket)

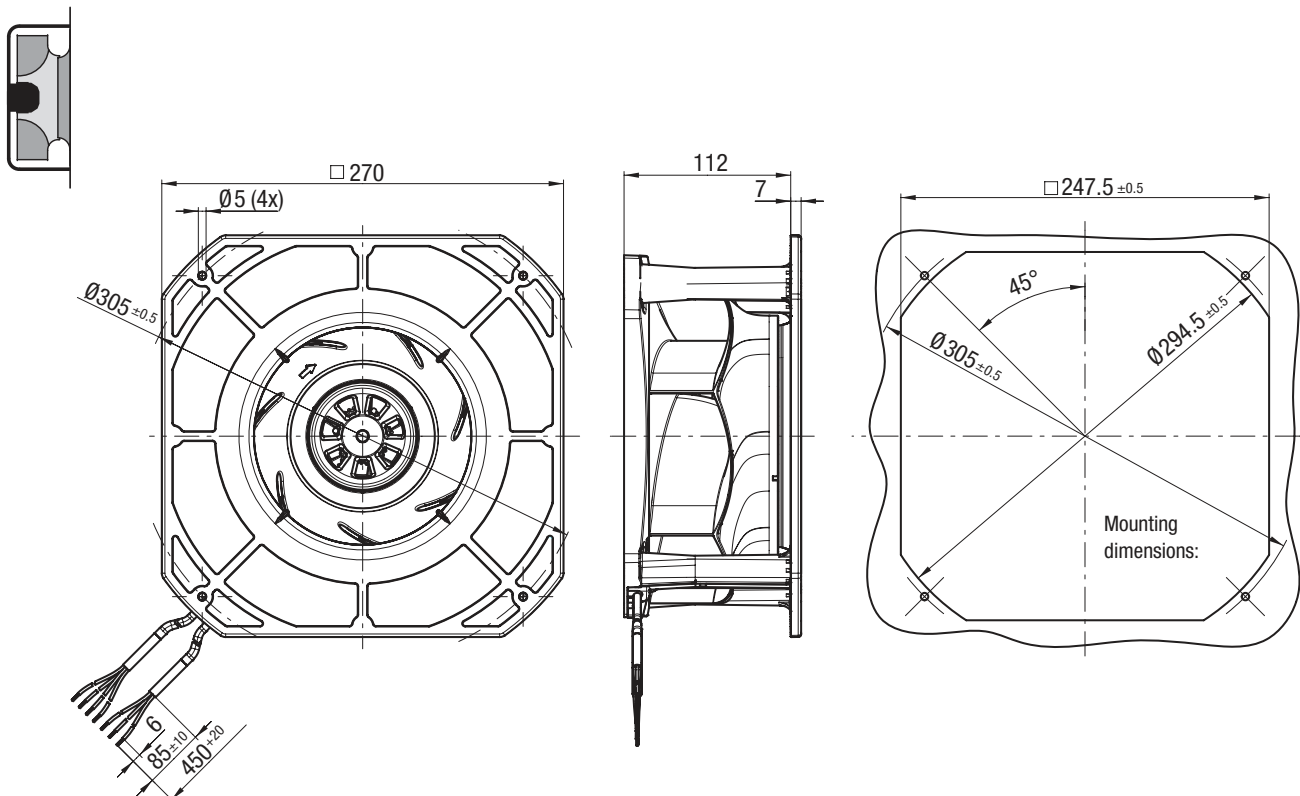

The R- and K-type cables shown refer to the 0-10 V/PWM design. For the illustration of the PWM design, see page 47.

EC centrifugal fans – RadiCal

backward curved, Ø 225, Speed-controlled, 115 W - Electronics



R3G 225-RH19-01 / R3G 225-RH19-05 (Centrifugal fan)

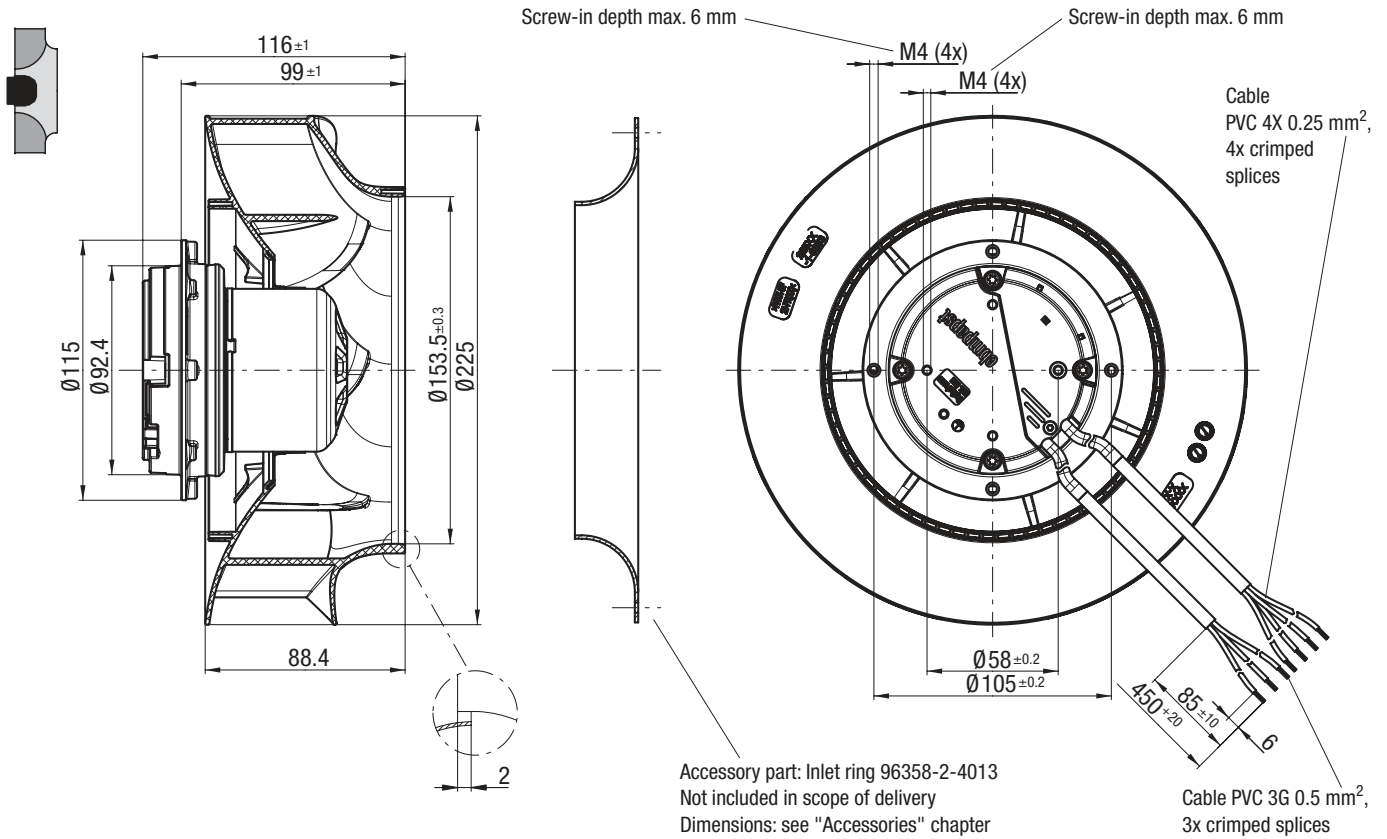

K3G 225-RH19-01 / K3G 225-RH19-05 (Centrifugal module with support basket)

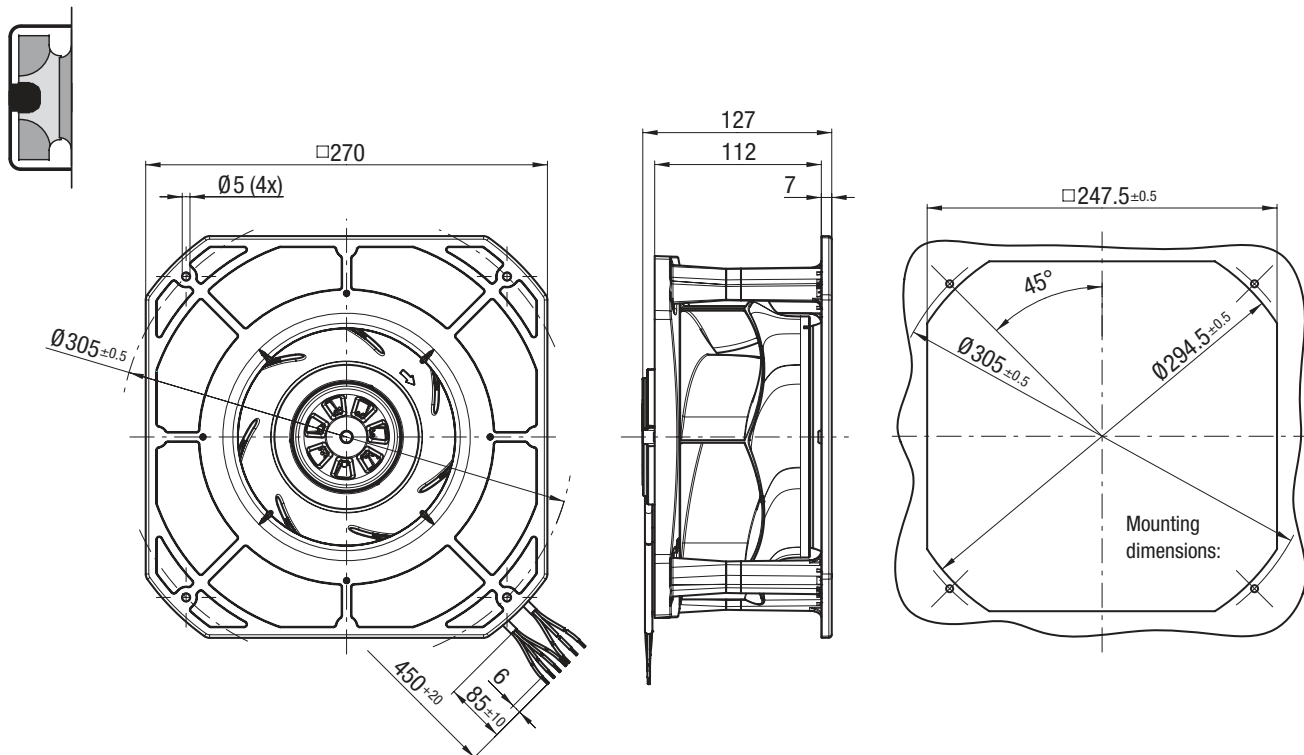

The R- and K-type cables shown refer to the 0-10 V/PWM design. For the illustration of the PWM design, see page 47.

EC centrifugal fans – RadiCal

backward curved, Ø 225, Speed-controlled, 170 W - Electronics



R3G 225-RE07-03 / R3G 225-RE07-05 / R3G 225-RE07-22 (Centrifugal fan)

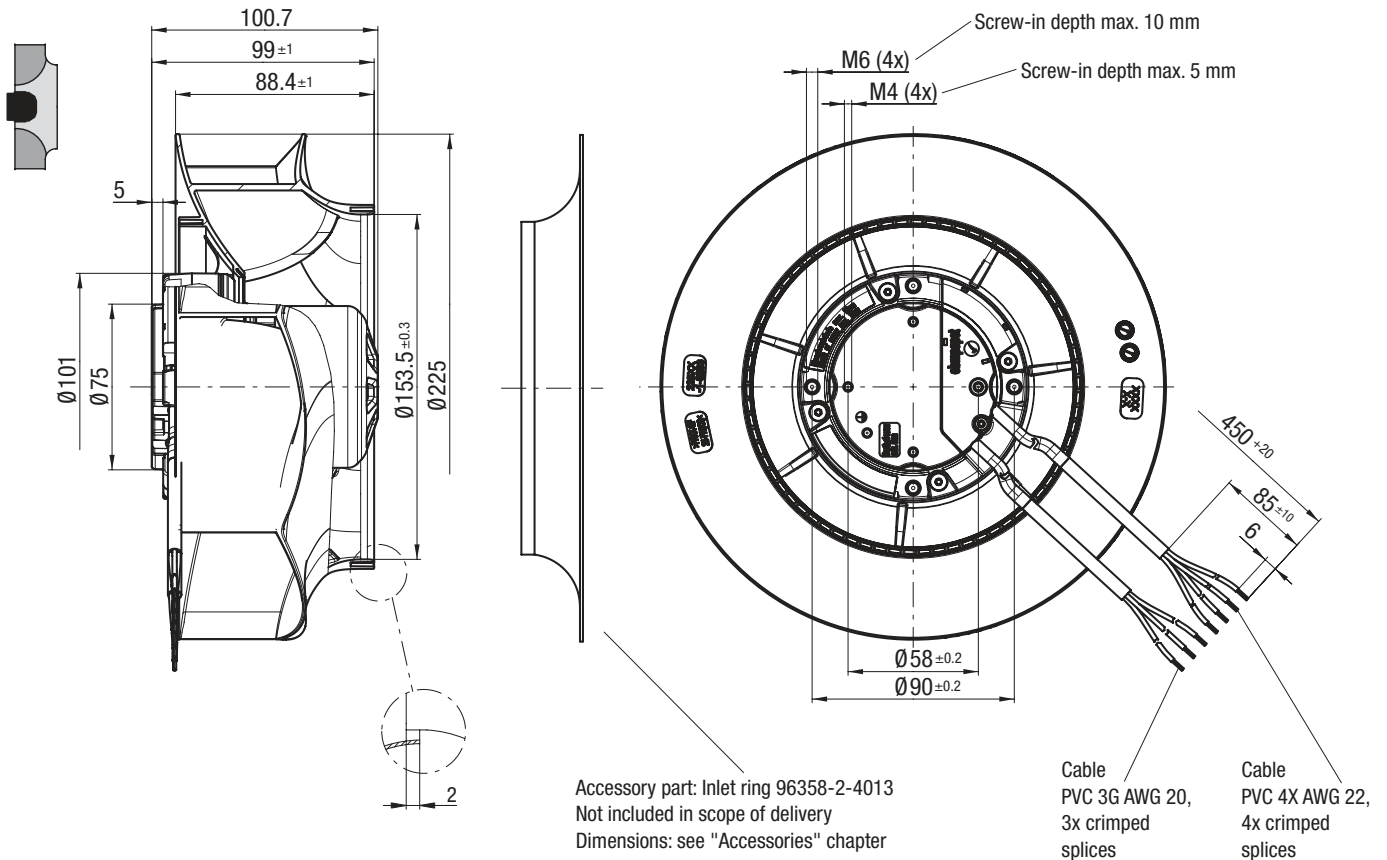

K3G 225-RE07-03 / K3G 225-RE07-05 / K3G 225-RE07-22 (Centrifugal module with support basket)

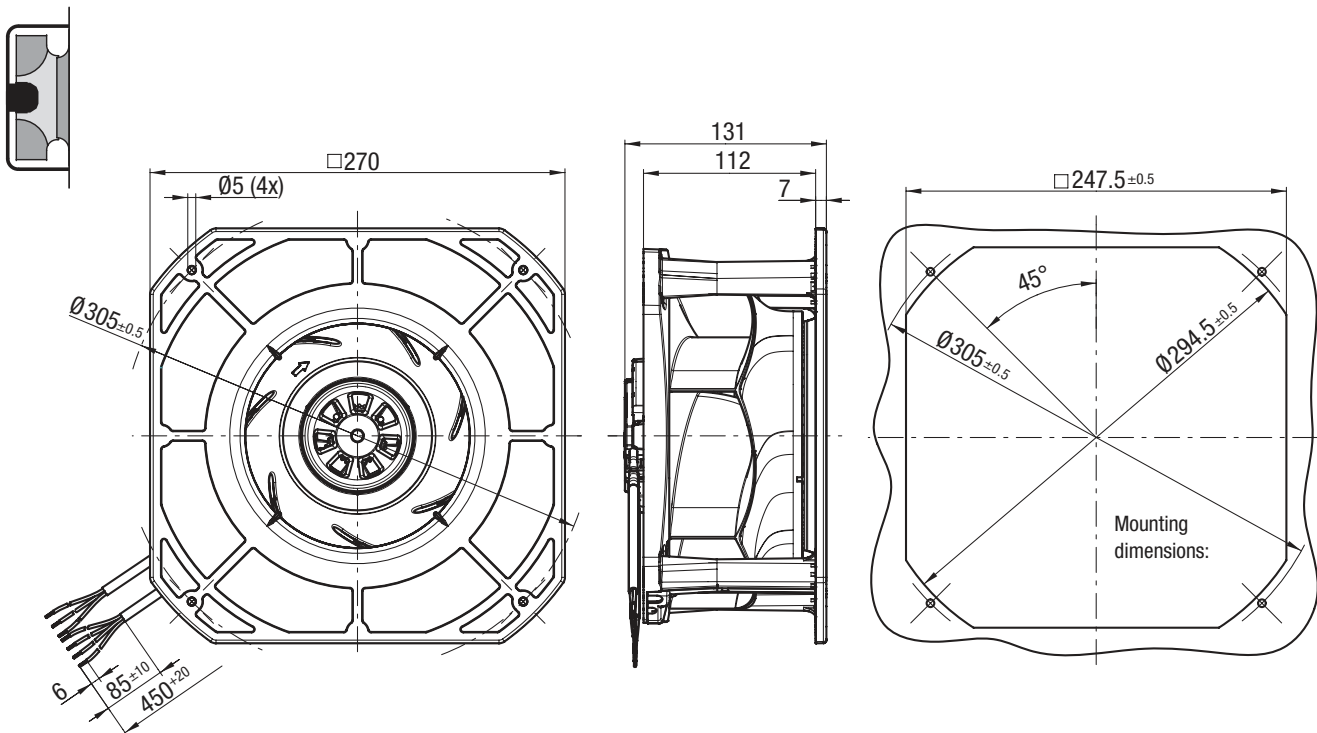

The R- and K-type cables shown refer to the 0-10 V/PWM design. For the illustration of the PWM respectively the MODBUS-RTU design, see page 47.

EC centrifugal fans – RadiCal

backward curved, with housing, Ø 225



- **Material:** Housing: Plastic
Impeller: Plastic
Rotor: Thick-film passivated
 - Ⓐ Ⓑ Ⓒ Electronics housing: Die-cast aluminium
 - Ⓓ Electronics cap: Sheet steel, hot-dip aluminized
- **Number of blades:** 7
- **Direction of rotation:** Clockwise viewed toward rotor
- **Degree of protection:** Ⓐ Ⓑ Ⓒ IP 54, Ⓓ IP 20; depending on installation and position
- **Insulation class:** "B"
- **Installation position:** Any
- **Condensation drainage holes:** None, open rotor
- **Mode:** Continuous operation (S1)
- **Mounting:** Maintenance-free ball bearings

Nominal data

| Type | Motor | Curve | Nominal voltage range | Frequency | Speed ⁽¹⁾ | Max. Input power ⁽¹⁾ | Max. Input current ⁽¹⁾ | Perm. ambient temp. | Techn. features and connection diagram |
|---------|------------|-------------|-----------------------|-----------|----------------------|---------------------------------|-----------------------------------|---------------------|--|
| Type | Motor | VAC | Hz | rpm | W | A | °C | | |
| *3G 225 | M3G 055-CF | Ⓐ 1~200-240 | 50/60 | 2200 | 85 | 0,75 | -25..+60 | P. 146 / RC3) | |
| *3G 225 | M3G 055-CF | Ⓐ 1~200-240 | 50/60 | 2200 | 85 | 0,75 | -25..+60 | P. 154 / RC10) | |
| *3G 225 | M3G 055-CF | Ⓑ 1~200-240 | 50/60 | 2450 | 105 | 0,90 | -25..+60 | P. 144 / RC1) | |
| *3G 225 | M3G 055-CF | Ⓑ 1~200-240 | 50/60 | 2450 | 105 | 0,90 | -25..+60 | P. 154 / RC10) | |
| *3G 225 | M3G 055-DF | Ⓒ 1~200-240 | 50/60 | 2900 | 165 | 1,40 | -25..+60 | P. 152 / RC8) | |
| *3G 225 | M3G 055-DF | Ⓒ 1~200-240 | 50/60 | 2900 | 165 | 1,40 | -25..+60 | P. 154 / RC10) | |
| *3G 225 | M3G 055-DF | Ⓒ 1~200-240 | 50/60 | 2900 | 165 | 1,40 | -25..+60 | P. 155 / RC11) | |
| *3G 225 | M3G 055-DF | Ⓓ 1~200-240 | 50/60 | 2900 | 165 | 1,40 | -25..+50 | P. 156 / RC12) | |

Subject to change

(1) Nominal data at operating point with maximum load and 230 VAC.

Curves:
Speed-controlled
0-10 V / PWM
PWM
MODBUS-RTU

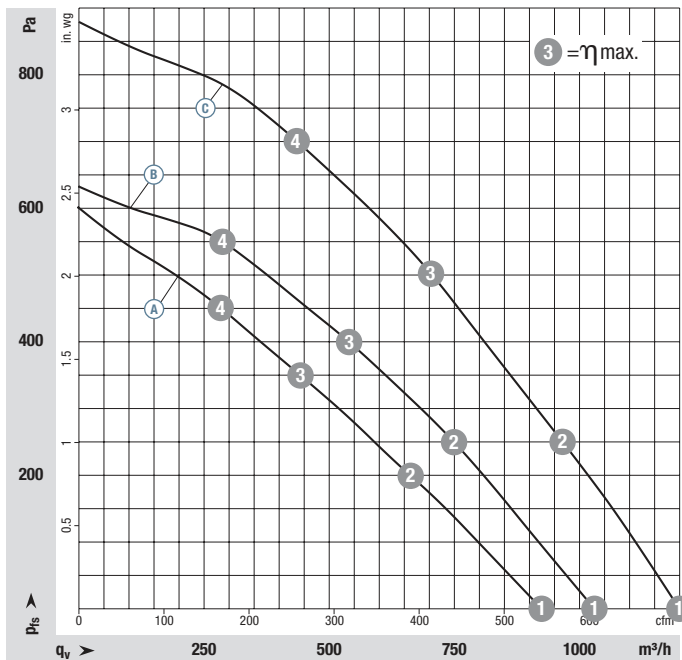

| | n rpm | P _{ed} W | I A | L _{wA} dB(A) |
|-----|-------|-------------------|------|-----------------------|
| Ⓐ ① | 2295 | 79 | 0,70 | 70 |
| Ⓐ ② | 2200 | 85 | 0,75 | 65 |
| Ⓐ ③ | 2265 | 81 | 0,71 | 65 |
| Ⓐ ④ | 2350 | 76 | 0,67 | 70 |
| Ⓑ ① | 2520 | 98 | 0,83 | 75 |
| Ⓑ ② | 2450 | 105 | 0,90 | 71 |
| Ⓑ ③ | 2490 | 103 | 0,87 | 69 |
| Ⓑ ④ | 2575 | 88 | 0,76 | 73 |
| Ⓒ ① | 2975 | 154 | 1,26 | 77 |
| Ⓒ ② | 2900 | 165 | 1,40 | 72 |
| Ⓒ ③ | 2890 | 165 | 1,40 | 70 |
| Ⓒ ④ | 2990 | 152 | 1,24 | 72 |

Air performance measured according to: ISO 5801, installation category A, with ebm-papst inlet ring without contact protection. Intake-side sound level: L_{wA} according to ISO 13347, L_{pA} measured at 1 m distance from fan axis. The values given are only applicable under the specified measuring conditions and may differ depending on the installation conditions. In the event of deviation from the standard configuration, the parameters must be checked in installed condition. See Page 162 ff. for detailed information.

- **Technical features:** See connection diagram P. 144 ff.
- **Touch current:** <= 3,5 mA according to IEC 60990 (measuring circuit Fig. 4)
- **Cable exit:** Variable
- **Protection class:** I (with customer connection of protective earth)
- **Conformity with standards:** EN 60335-1; CE
- **Approvals:** VDE, UL, CSA, CCC, EAC on request
- **Efficiency:** Ecodesign EU regulation EU 327/2011



Weight Centrifugal fan with housing

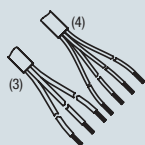

Cables

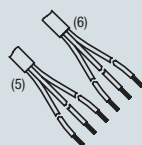

Cables

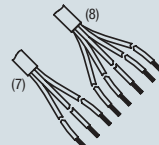

Cables

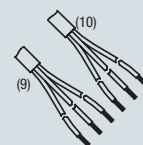

Cables

| Centrifugal fan with housing | kg | Speed-controlled 0-10 V / PWM | Speed-controlled PWM | Speed-controlled MODBUS-RTU | Sensor-controlled MODBUS-RTU |
|----------------------------------|------|-------------------------------|----------------------|-----------------------------|------------------------------|
| G3G 225-RD05 -02 | 2,60 | X | | | |
| G3G 225-RD05 -05 | 2,60 | | X | | |
| G3G 225-RH19 -01 | 2,70 | X | | | |
| G3G 225-RH19 -05 | 2,70 | | X | | |
| G3G 225-RE07 -03 | 3,00 | X | | | |
| G3G 225-RE07 -05 | 3,00 | | X | | |
| G3G 225-RE07 -22 | 3,00 | | | X | |
| G3G 225-RR07 -04 ⁽¹¹⁾ | 3,10 | | | | X |

(11) Freely programmable volume flows (constant air flow volume with tolerance related ± 1 % of final value)

(3) PVC AWG 20, 3x splices
(4) PVC AWG 22, 4x splices

(5) PVC AWG 20, 3x splices
(6) PVC AWG 22, 3x splices

(7) PVC AWG 20, 3x splices
(8) PVC AWG 22, 5x splices

(9) PVC AWG 20, 3x splices
(10) PVC AWG 22, 3x splices

Curves:
Sensor-controlled
MODBUS-RTU

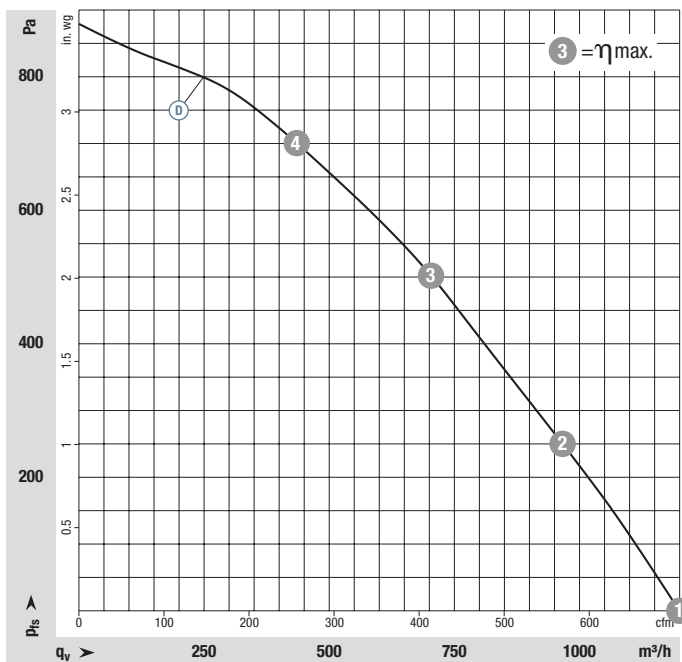

| | n rpm | P _{ed} W | I A | L _{wA} dB(A) |
|-----|-------|-------------------|------|-----------------------|
| ⓓ 1 | 2975 | 154 | 1,26 | 77 |
| ⓓ 2 | 2900 | 165 | 1,40 | 72 |
| ⓓ 3 | 2890 | 165 | 1,40 | 70 |
| ⓓ 4 | 2990 | 152 | 1,24 | 72 |

Air performance measured according to: ISO 5801, installation category A, with ebm-papst inlet ring without contact protection. Intake-side sound level: L_{wA} according to ISO 13347, L_{pA} measured at 1 m distance from fan axis. The values given are only applicable under the specified measuring conditions and may differ depending on the installation conditions. In the event of deviation from the standard configuration, the parameters must be checked in installed condition. See Page 162 ff. for detailed information.

EC centrifugal fans – RadiCal

backward curved, with housing, Ø 225



G3G 225-RE07-03 / G3G 225-RE07-05 / G3G 225-RE07-22 (Centrifugal fan with housing) / Speed-controlled, 170 W - Electronics

Tapping hole prepared for self-tapping screw for fastening plastics (Remform) dia. 4 mm, screw-in depth max. 15 mm. The torque is to be determined on the basis of the screw.

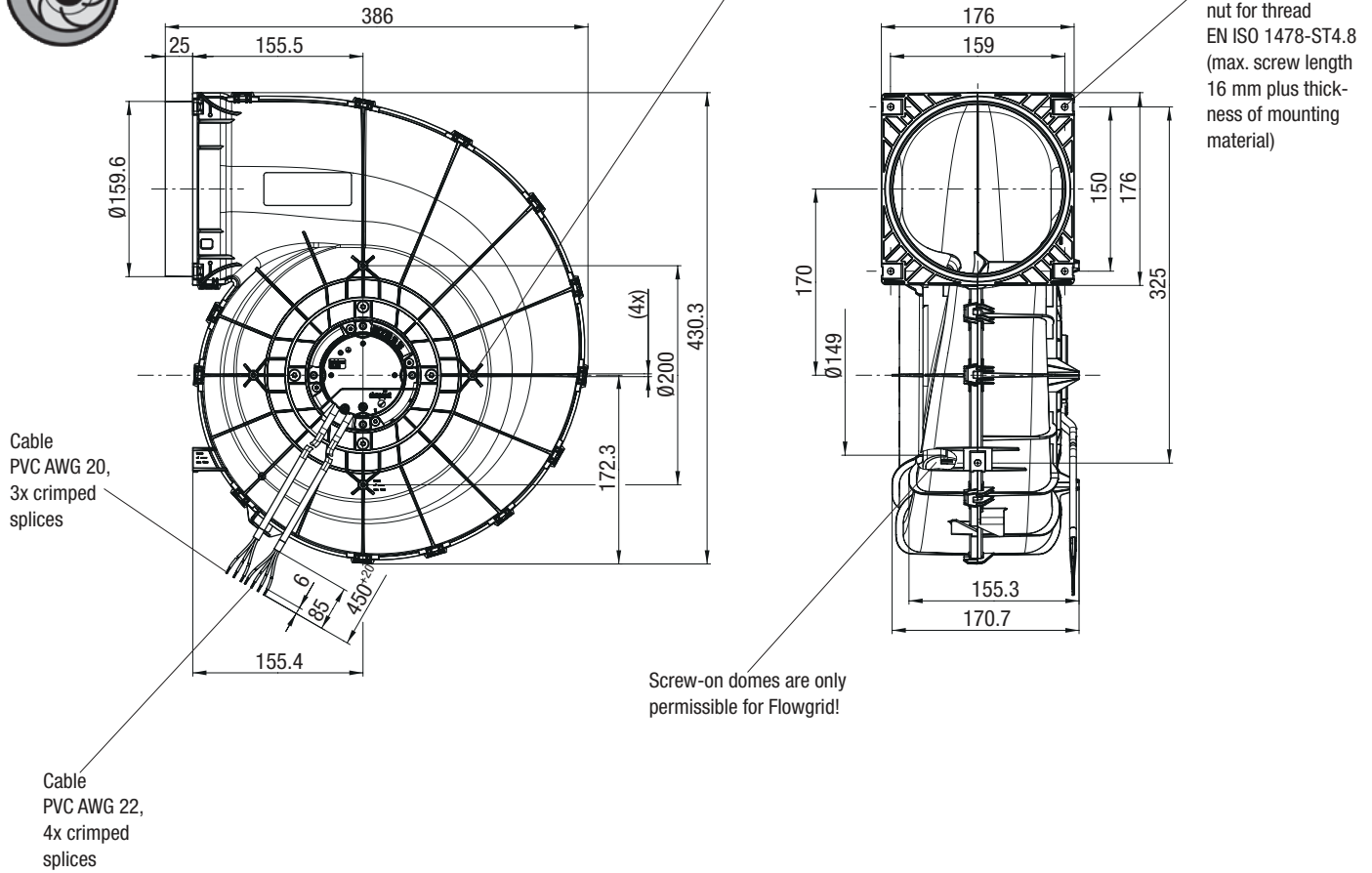

The cables shown refer to the 0-10 V/PWM design. For the illustration of the PWM respectively the MODBUS-RTU design, see page 55.

EC centrifugal fans – RadiCal

backward curved, Ø 250



- **Material:** Housing: Plastic
Impeller: Plastic
Rotor: Thick-film passivated
Electronics housing: Die-cast aluminium
- **Number of blades:** 7
- **Direction of rotation:** Clockwise viewed toward rotor
- **Degree of protection:** IP 54
- **Insulation class:** "B"
- **Installation position:** Any
- **Condensation drainage holes:** None, open rotor
- **Mode:** Continuous operation (S1)
- **Mounting:** Maintenance-free ball bearings

| Nominal data | | Curve | Nominal voltage range | Frequency | Speed ⁽¹⁾ | Max. Input power ⁽¹⁾ | Max. Input current ⁽¹⁾ | Perm. ambient temp. | Techn. features and connection diagram |
|--------------|------------|-------------|-----------------------|-----------|----------------------|---------------------------------|-----------------------------------|---------------------|--|
| Type | Motor | VAC | Hz | rpm | W | A | °C | | |
| *3G 250 | M3G 055-CF | Ⓐ 1~200-240 | 50/60 | 1955 | 80 | 0,70 | -25..+60 | P. 145 / RC2) | |
| *3G 250 | M3G 055-DF | Ⓑ 1~200-240 | 50/60 | 2510 | 170 | 1,40 | -25..+60 | P. 145 / RC2) | |
| *3G 250 | M3G 055-CF | Ⓒ 1~200-240 | 50/60 | 1955 | 80 | 0,70 | -25..+60 | P. 146 / RC3) | |
| *3G 250 | M3G 055-CF | Ⓒ 1~200-240 | 50/60 | 1955 | 80 | 0,70 | -25..+60 | P. 154 / RC10) | |
| *3G 250 | M3G 055-DF | Ⓓ 1~200-240 | 50/60 | 2250 | 115 | 1,00 | -25..+60 | P. 144 / RC1) | |
| *3G 250 | M3G 055-DF | Ⓓ 1~200-240 | 50/60 | 2250 | 115 | 1,00 | -25..+60 | P. 154 / RC10) | |
| *3G 250 | M3G 055-DF | Ⓔ 1~200-240 | 50/60 | 2510 | 170 | 1,40 | -25..+60 | P. 152 / RC8) | |
| *3G 250 | M3G 055-DF | Ⓔ 1~200-240 | 50/60 | 2510 | 170 | 1,40 | -25..+60 | P. 154 / RC10) | |
| *3G 250 | M3G 055-DF | Ⓔ 1~200-240 | 50/60 | 2510 | 170 | 1,40 | -25..+60 | P. 155 / RC11) | |

Subject to change

(1) Nominal data at operating point with maximum load and 230 VAC.

Curves: 2 Speed stages

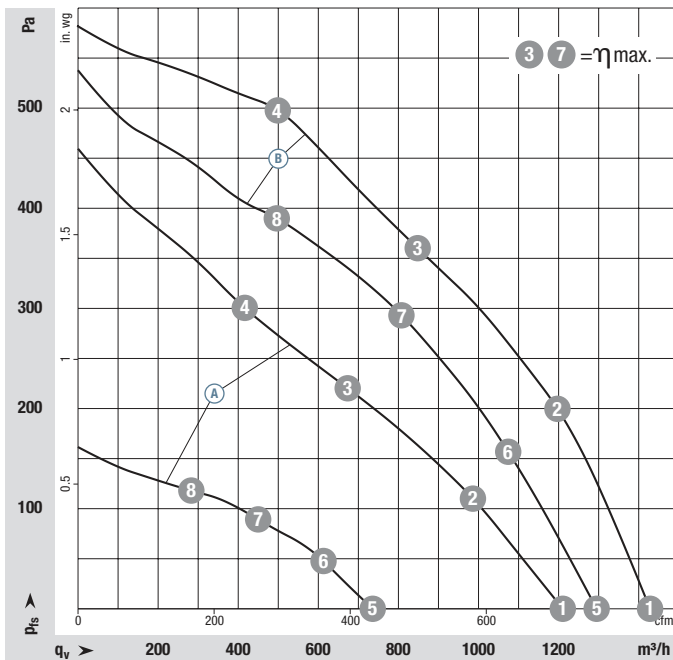

| | n rpm | P _{ed} W | I A | L _{wA} dB(A) |
|-----|-------|-------------------|------|-----------------------|
| Ⓐ ① | 2195 | 80 | 0,70 | 71 |
| Ⓐ ② | 2065 | 80 | 0,70 | 66 |
| Ⓐ ③ | 1955 | 80 | 0,70 | 61 |
| Ⓐ ④ | 2040 | 80 | 0,70 | 67 |
| Ⓐ ⑤ | 1345 | 21 | 0,23 | 60 |
| Ⓐ ⑥ | 1315 | 24 | 0,25 | 57 |
| Ⓐ ⑦ | 1305 | 25 | 0,26 | 53 |
| Ⓐ ⑧ | 1315 | 24 | 0,26 | 57 |
| Ⓑ ① | 2655 | 143 | 1,18 | 76 |
| Ⓑ ② | 2630 | 170 | 1,40 | 71 |
| Ⓑ ③ | 2510 | 170 | 1,40 | 67 |
| Ⓑ ④ | 2620 | 168 | 1,39 | 73 |
| Ⓑ ⑤ | 2415 | 108 | 0,92 | 72 |
| Ⓑ ⑥ | 2360 | 122 | 1,03 | 67 |
| Ⓑ ⑦ | 2330 | 130 | 1,10 | 64 |
| Ⓑ ⑧ | 2360 | 121 | 1,03 | 68 |

Air performance measured according to: ISO 5801, installation category A, with ebm-papst inlet ring without contact protection. Intake-side sound level: L_{wA} according to ISO 13347, L_{pA} measured at 1 m distance from fan axis. The values given are only applicable under the specified measuring conditions and may differ depending on the installation conditions. In the event of deviation from the standard configuration, the parameters must be checked in installed condition. See Page 162 ff. for detailed information.

- **Technical features:** See connection diagram P. 144 ff.
- **EMC:** Interference emission according to EN 61000-6-3
Immunity to interference according to EN 61000-6-2
Circuit feedback according to EN 61000-3-2/3
- **Touch current:** < 3,5 mA according to IEC 60990 (measuring circuit Fig. 4)
- **Cable exit:** Variable
- **Protection class:** I (with customer connection of protective earth)
- **Conformity with standards:** EN 60335-1, CE
- **Approvals:** VDE, UL, CSA, CCC, EAC on request
- **Efficiency:** Ecodesign EU regulation EU 327/2011

| Centrifugal fan | kg | Centrifugal module w. support basket | kg | 2 Speed stages | Speed-controlled 0-10 V / PWM | Speed-controlled PWM | Speed-controlled MODBUS-RTU |
|------------------|------|--------------------------------------|------|----------------|-------------------------------|----------------------|-----------------------------|
| R3G 250-RD17 -01 | 1,50 | K3G 250-RD17 -01 | 2,30 | X | | | |
| R3G 250-RE07 -05 | 1,90 | K3G 250-RE07 -05 | 2,70 | X | | | |
| R3G 250-RD17 -03 | 1,50 | K3G 250-RD17 -03 | 2,30 | | X | | |
| R3G 250-RD17 -05 | 1,50 | K3G 250-RD17 -05 | 2,30 | | | X | |
| R3G 250-RH13 -01 | 1,60 | K3G 250-RH13 -01 | 2,40 | | X | | |
| R3G 250-RH13 -05 | 1,60 | K3G 250-RH13 -05 | 2,40 | | | X | |
| R3G 250-RE07 -07 | 1,90 | K3G 250-RE07 -07 | 2,70 | | X | | |
| R3G 250-RE07 -21 | 1,90 | K3G 250-RE07 -21 | 2,70 | | | X | |
| R3G 250-RE07 -22 | 1,90 | K3G 250-RE07 -22 | 2,70 | | | | X |

(2) PVC AWG 20, 4x splices (3) PVC AWG 20, 3x splices (4) PVC AWG 22, 4x splices (5) PVC AWG 20, 3x splices (6) PVC AWG 22, 3x splices (7) PVC AWG 20, 3x splices (8) PVC AWG 22, 5x splices

Curves:
Speed-controlled
0-10 V / PWM
PWM
MODBUS-RTU

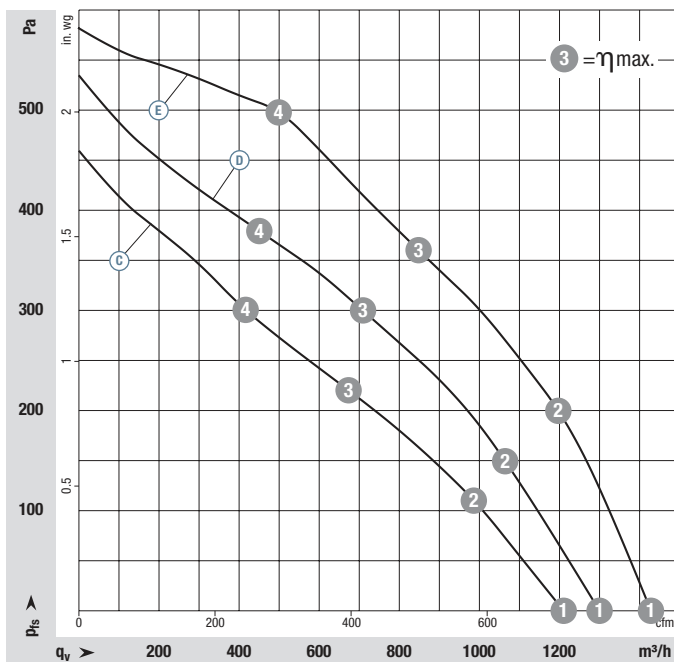

| | n rpm | P _{ed} W | I A | L _{wA} dB(A) |
|-----|-------|-------------------|------|-----------------------|
| ⓐ 1 | 2195 | 80 | 0,70 | 71 |
| ⓐ 2 | 2070 | 80 | 0,70 | 66 |
| ⓐ 3 | 1955 | 80 | 0,70 | 62 |
| ⓐ 4 | 2060 | 80 | 0,70 | 68 |
| ⓓ 1 | 2385 | 101 | 0,86 | 73 |
| ⓓ 2 | 2310 | 115 | 1,00 | 67 |
| ⓓ 3 | 2250 | 115 | 1,00 | 65 |
| ⓓ 4 | 2320 | 113 | 0,96 | 68 |
| ⓔ 1 | 2650 | 143 | 1,18 | 77 |
| ⓔ 2 | 2625 | 170 | 1,40 | 71 |
| ⓔ 3 | 2510 | 170 | 1,40 | 67 |
| ⓔ 4 | 2650 | 168 | 1,39 | 72 |

Air performance measured according to: ISO 5801, installation category A, with ebm-papst inlet ring without contact protection. Intake-side sound level: L_{wA} according to ISO 13347, L_{pA} measured at 1 m distance from fan axis. The values given are only applicable under the specified measuring conditions and may differ depending on the installation conditions. In the event of deviation from the standard configuration, the parameters must be checked in installed condition. See Page 162 ff. for detailed information.

EC centrifugal fans – RadiCal

backward curved, Ø 250, 2 Speed stages, 85 W - Electronics



R3G 250-RD17-01 (Centrifugal fan)

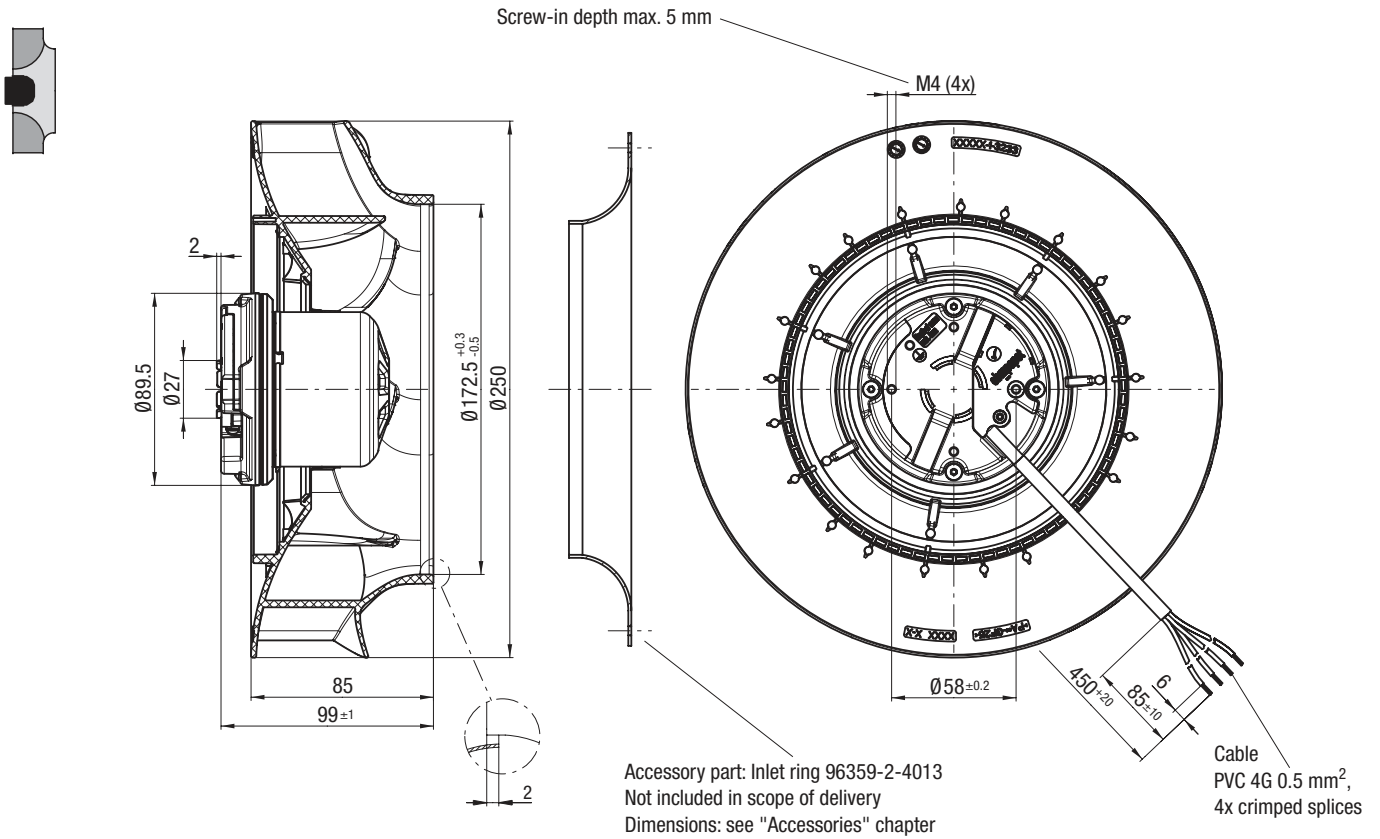

K3G 250-RD17-01 (Centrifugal module with support basket)

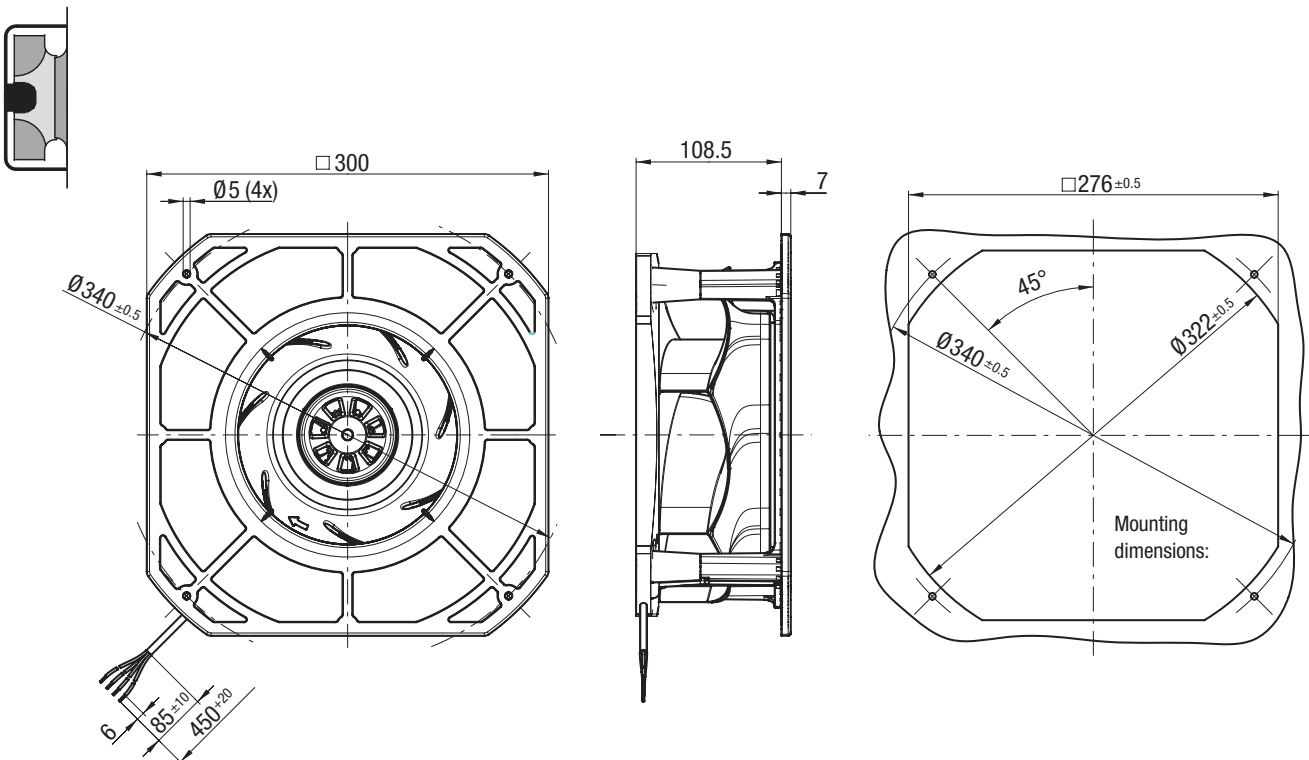

EC centrifugal fans – RadiCal

backward curved, Ø 250, Speed-controlled, 85 W - Electronics



R3G 250-RD17-03 / R3G 250-RD17-05 (Centrifugal fan)

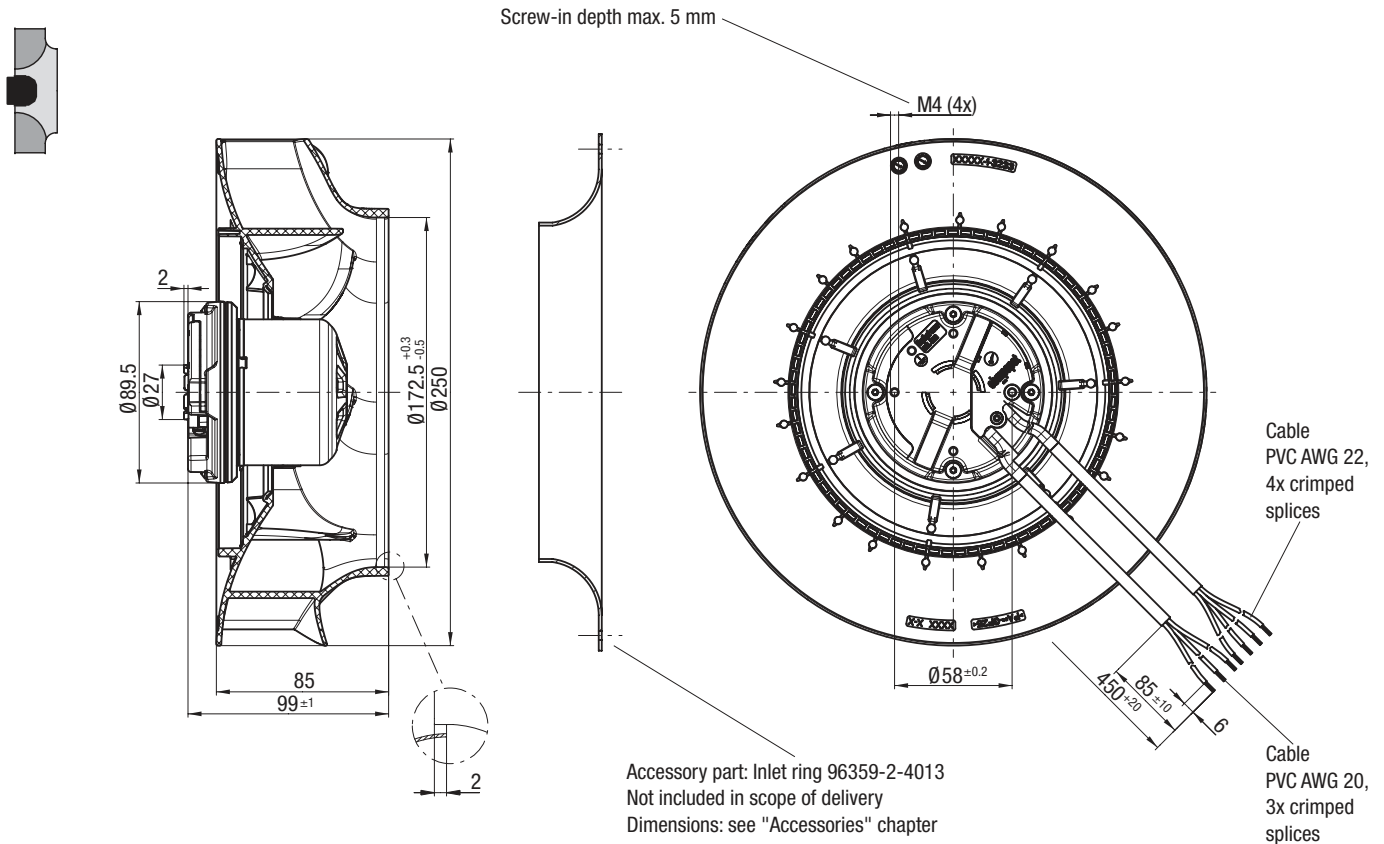

K3G 250-RD17-03 / K3G 250-RD17-05 (Centrifugal module with support basket)

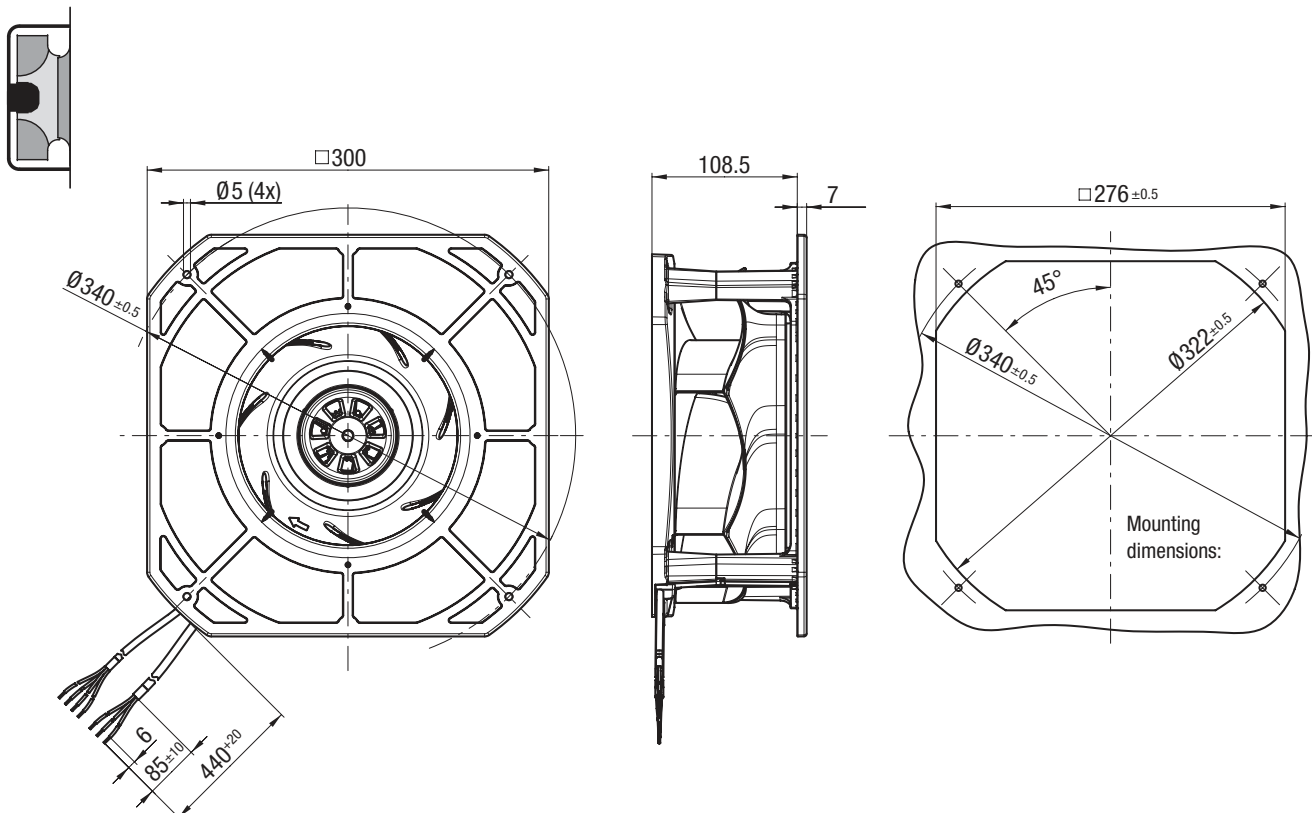

The R- and K-type cables shown refer to the 0-10 V/PWM design. For the illustration of the PWM design, see page 61.

EC centrifugal fans – RadiCal

backward curved, Ø 250, Speed-controlled, 115 W - Electronics



R3G 250-RH13-01 / R3G 250-RH13-05 (Centrifugal fan)

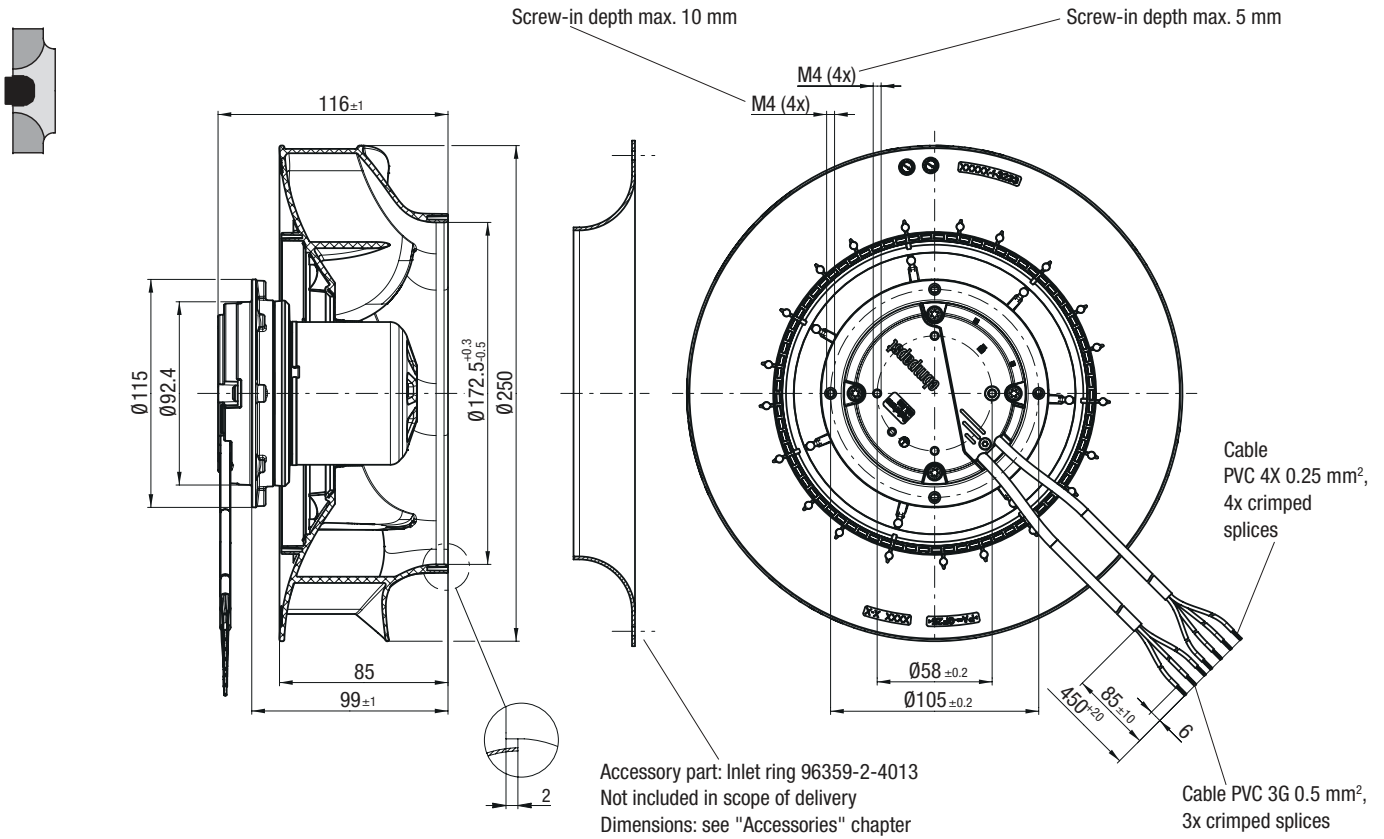

K3G 250-RH13-01 / K3G 250-RH13-05 (Centrifugal module with support basket)

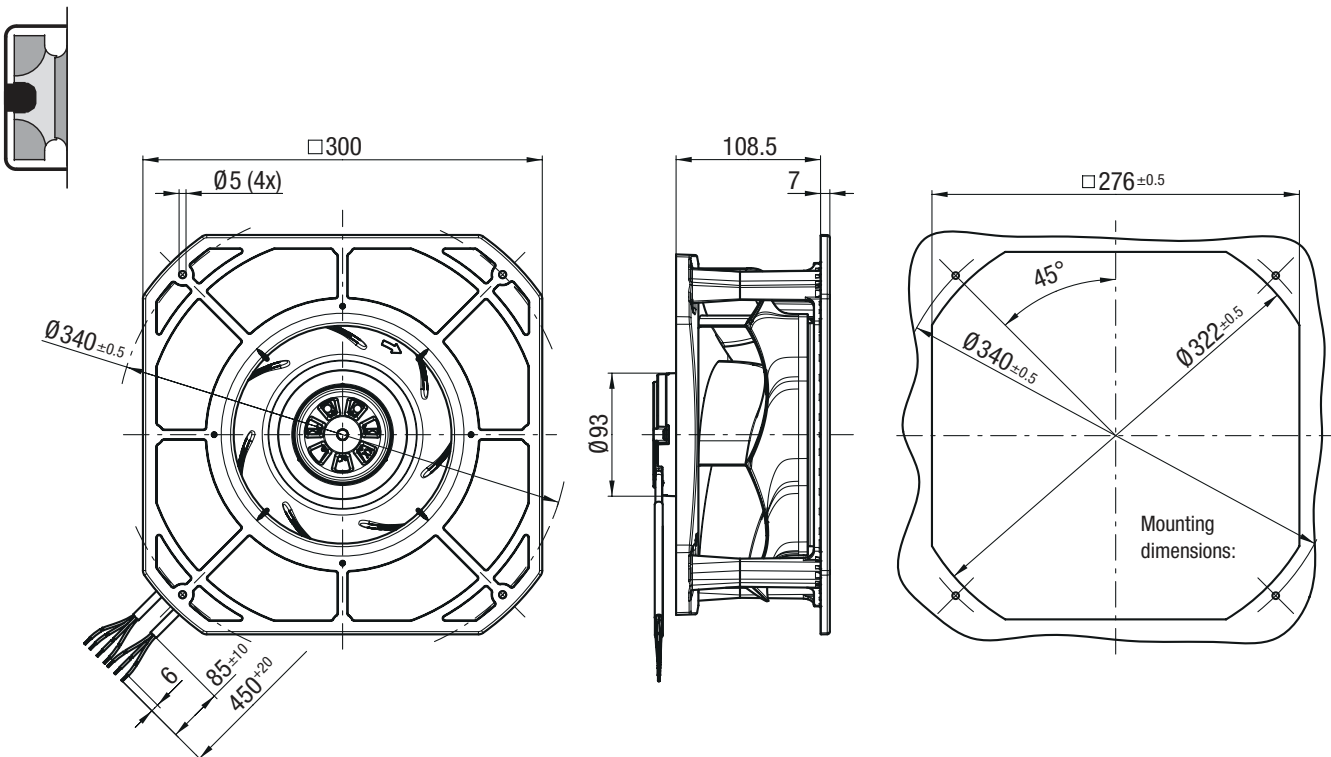

The R- and K-type cables shown refer to the 0-10 V/PWM design. For the illustration of the PWM design, see page 61.

EC centrifugal fans – RadiCal

backward curved, Ø 250, Speed-controlled, 170 W - Electronics



R3G 250-RE07-07 / R3G 250-RE07-21 / R3G 250-RE07-22 (Centrifugal fan)

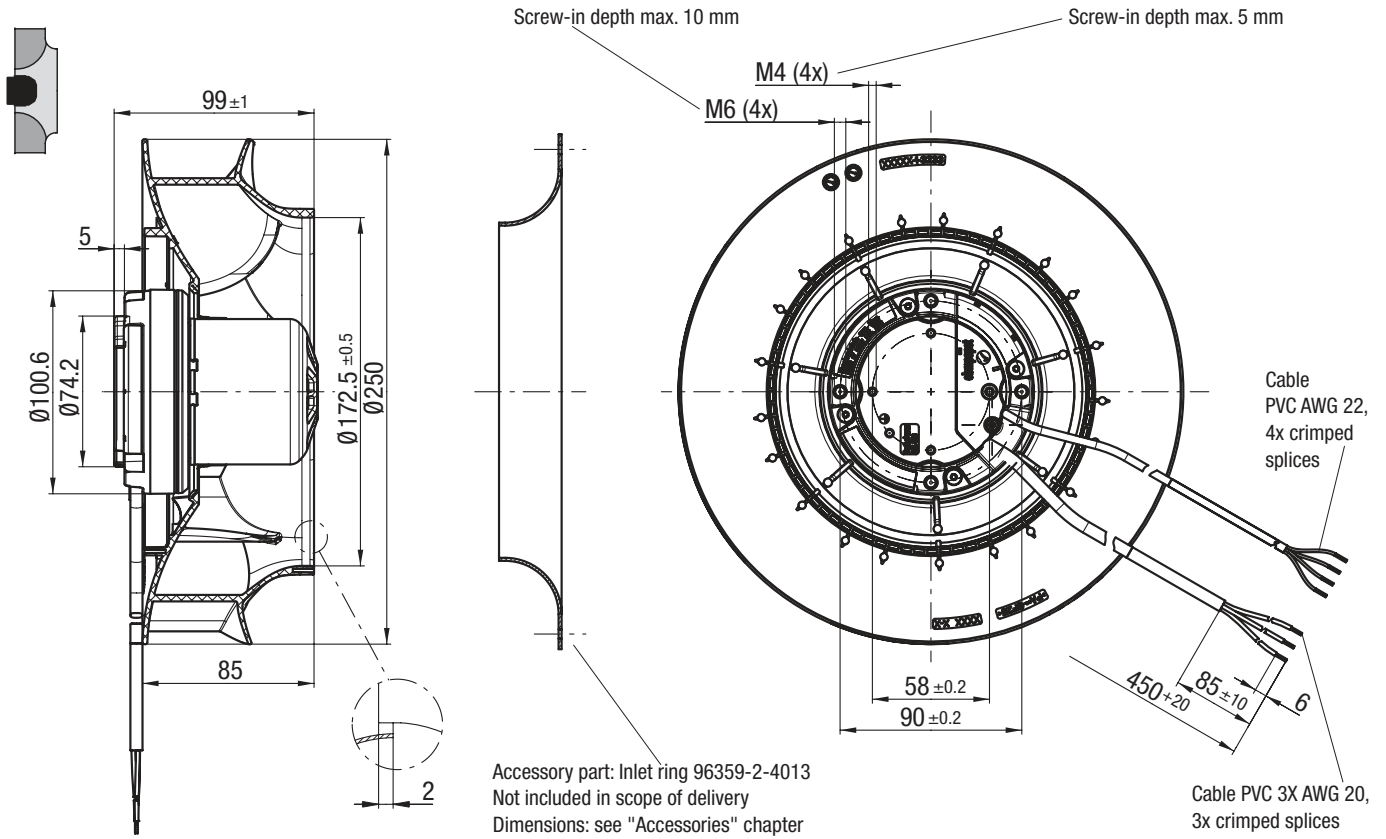

K3G 250-RE07-07 / K3G 250-RE07-21 / K3G 250-RE07-22 (Centrifugal module with support basket)

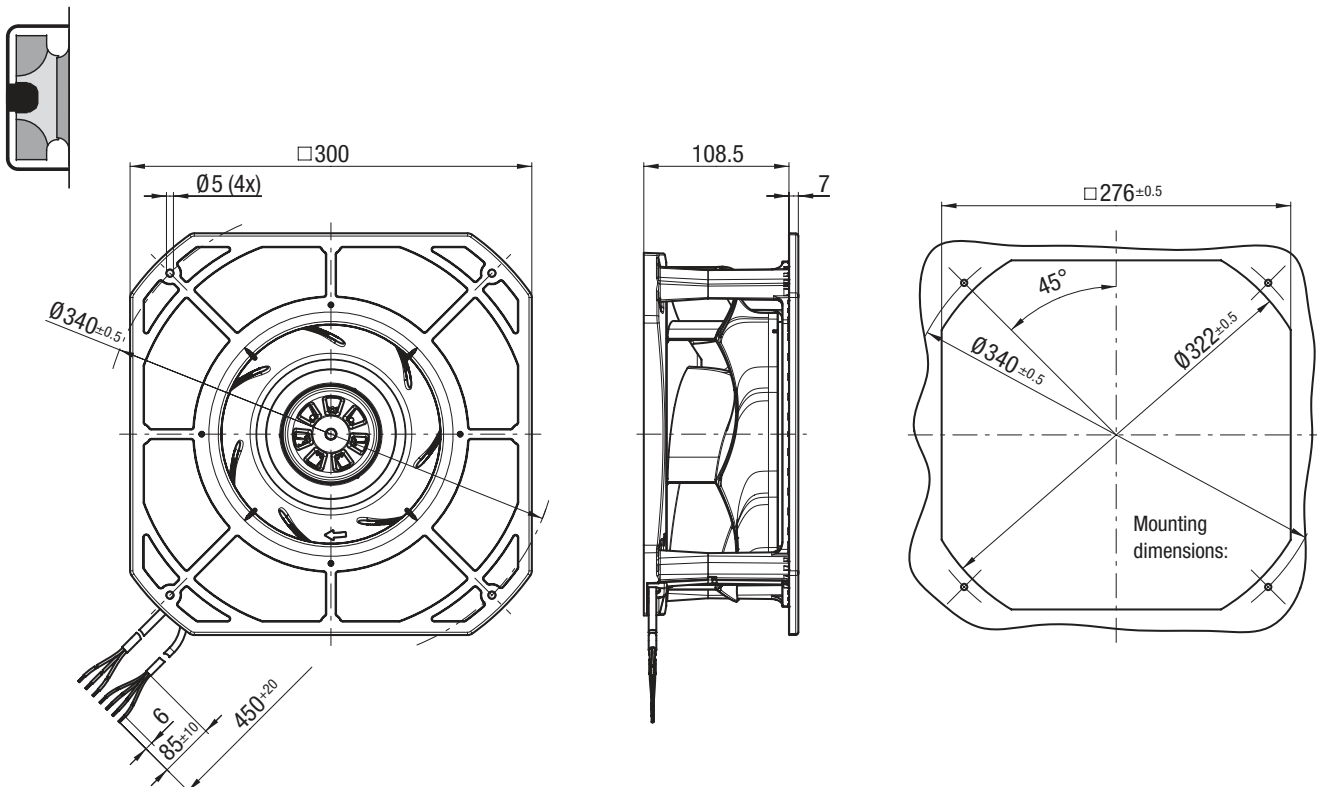

The R- and K-type cables shown refer to the 0-10 V/PWM design. For the illustration of the PWM respectively the MODBUS-RTU design, see page 61.

EC centrifugal fans – RadiCal

backward curved, Ø 175 - Ø 250



- **Material:** Housing: Plastic
Impeller: Plastic
Rotor: Thick-film passivated
Electronics housing: Die-cast aluminium
- **Number of blades:** 7
- **Direction of rotation:** Clockwise viewed toward rotor
- **Degree of protection:** IP 54
- **Insulation class:** "B"
- **Installation position:** Any
- **Condensation drainage holes:** None, open rotor
- **Mode:** Continuous operation (S1)
- **Mounting:** Maintenance-free ball bearings

Nominal data

| Type | Motor | Curve | Nominal voltage range | Frequency | Speed ⁽¹⁾ | Max. Input power ⁽¹⁾ | Max. Input current ⁽¹⁾ | Perm. ambient temp. | Techn. features and connection diagram |
|---------|------------|-------------|-----------------------|-----------|----------------------|---------------------------------|-----------------------------------|---------------------|--|
| Type | Motor | VAC | Hz | rpm | W | A | °C | | |
| *1G 175 | M1G 055-CF | Ⓐ 1~200-240 | 50/60 | 4050 | 100 | 0,85 | -25..+60 | P. 157 / RC13) | |
| *1G 190 | M1G 055-CF | Ⓑ 1~200-240 | 50/60 | 3550 | 100 | 0,85 | -25..+60 | P. 157 / RC13) | |
| *1G 220 | M1G 055-CF | Ⓒ 1~200-240 | 50/60 | 2700 | 100 | 0,80 | -25..+60 | P. 157 / RC13) | |
| *1G 225 | M1G 055-DF | Ⓓ 1~200-240 | 50/60 | 2450 | 100 | 0,90 | -25..+60 | P. 157 / RC13) | |
| *1G 250 | M1G 055-DF | Ⓔ 1~200-240 | 50/60 | 2150 | 100 | 0,85 | -25..+60 | P. 157 / RC13) | |

Subject to change

(1) Nominal data at operating point with maximum load and 230 VAC.

Curves: Speed-controlled PWM

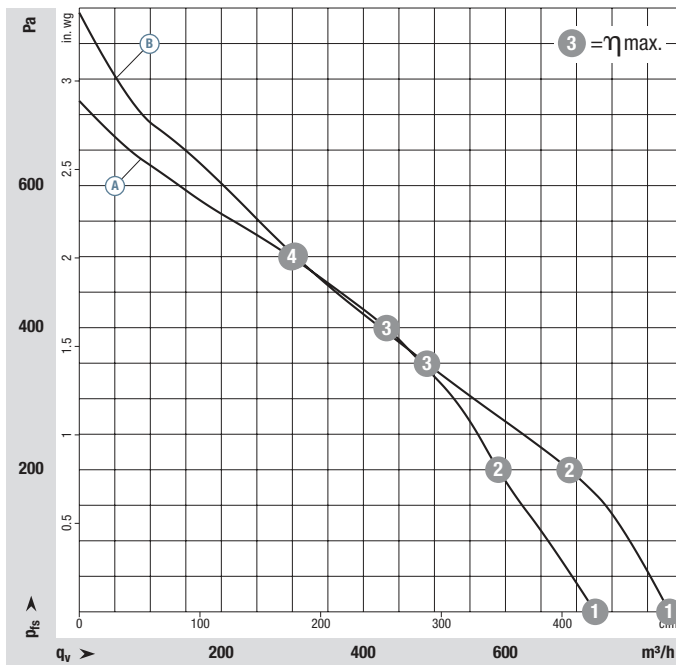

| | n rpm | P _{ed} W | I A | L _{wA} dB(A) |
|-----|-------|-------------------|------|-----------------------|
| Ⓐ ① | 4220 | 93 | 0,78 | 75 |
| Ⓐ ② | 4120 | 100 | 0,83 | 72 |
| Ⓐ ③ | 4050 | 100 | 0,85 | 71 |
| Ⓐ ④ | 4115 | 100 | 0,84 | 74 |
| Ⓑ ① | 3890 | 100 | 0,85 | 77 |
| Ⓑ ② | 3770 | 100 | 0,85 | 72 |
| Ⓑ ③ | 3550 | 100 | 0,85 | 69 |
| Ⓑ ④ | 3645 | 100 | 0,85 | 72 |

Air performance measured according to: ISO 5801, installation category A, with ebm-papst inlet ring without contact protection. Intake-side sound level: L_{wA} according to ISO 13347, L_{pA} measured at 1 m distance from fan axis. The values given are only applicable under the specified measuring conditions and may differ depending on the installation conditions. In the event of deviation from the standard configuration, the parameters must be checked in installed condition. See Page 162 ff. for detailed information.

- **Technical features:** See connection diagram P. 157
- **EMC:** Interference emission according to EN 61000-6-3 (household environment)
Immunity to interference according to EN 61000-6-2 (industrial environment)
Circuit feedback according to EN 61000-3-2/3
- **Touch current:** <= 3,5 mA
- **Cable exit:** Variable
- **Protection class:** I (with customer connection of protective earth)
- **Conformity with standards:** EN 60335-1, CE
- **Approvals:** on request
- **Efficiency:** Ecodesign EU regulation EU 327/2011



Weight
Centrifugal fan



Weight
Centrifugal module
w. support basket

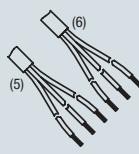

Cables

| Centrifugal fan | kg | Centrifugal module w. support basket | kg | Speed-controlled PWM |
|------------------|------|--------------------------------------|------|----------------------|
| R1G 175-RF04 -01 | 1,25 | K1G 175-RF04 -01 | 1,45 | X |
| R1G 190-RF04 -01 | 1,30 | K1G 190-RF04 -01 | 1,65 | X |
| R1G 220-RF01 -01 | 1,35 | K1G 220-RF01 -01 | 1,95 | X |
| R1G 225-RG04 -01 | 1,65 | K1G 225-RG04 -01 | 2,25 | X |
| R1G 250-RG01 -01 | 1,70 | K1G 250-RG01 -01 | 2,50 | X |

(5) PVC AWG 20, 3x splices
(6) PVC AWG 22, 3x splices

Curves:
Speed-controlled
PWM

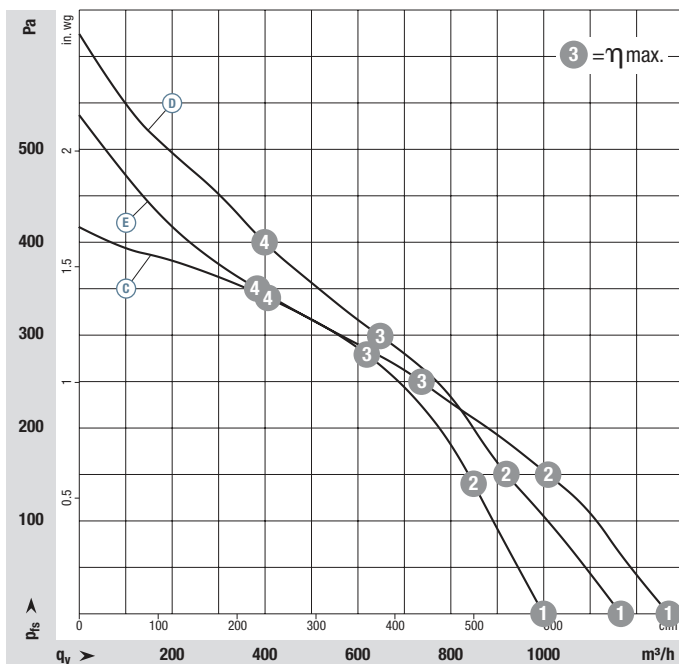

| | n rpm | P _{ed} W | I A | L _{wA} dB(A) |
|-----|-------|-------------------|------|-----------------------|
| ⓐ ① | 2700 | 71 | 0,61 | 70 |
| ⓐ ② | 2700 | 86 | 0,73 | 67 |
| ⓐ ③ | 2700 | 100 | 0,80 | 67 |
| ⓐ ④ | 2700 | 91 | 0,77 | 68 |
| ⓓ ① | 2655 | 100 | 0,90 | 74 |
| ⓓ ② | 2460 | 100 | 0,90 | 69 |
| ⓓ ③ | 2450 | 100 | 0,90 | 67 |
| ⓓ ④ | 2590 | 100 | 0,90 | 70 |
| ⓔ ① | 2290 | 88 | 0,74 | 78 |
| ⓔ ② | 2180 | 97 | 0,81 | 71 |
| ⓔ ③ | 2150 | 100 | 0,85 | 68 |
| ⓔ ④ | 2200 | 95 | 0,80 | 69 |

Air performance measured according to: ISO 5801, installation category A, with ebm-papst inlet ring without contact protection. Intake-side sound level: L_{wA} according to ISO 13347, L_{pA} measured at 1 m distance from fan axis. The values given are only applicable under the specified measuring conditions and may differ depending on the installation conditions. In the event of deviation from the standard configuration, the parameters must be checked in installed condition. See Page 162 ff. for detailed information.

EC centrifugal fans – RadiCal

backward curved, Ø 175, Speed-controlled, 100 W - Electronics



R1G 175-RF04-01 (Centrifugal fan)

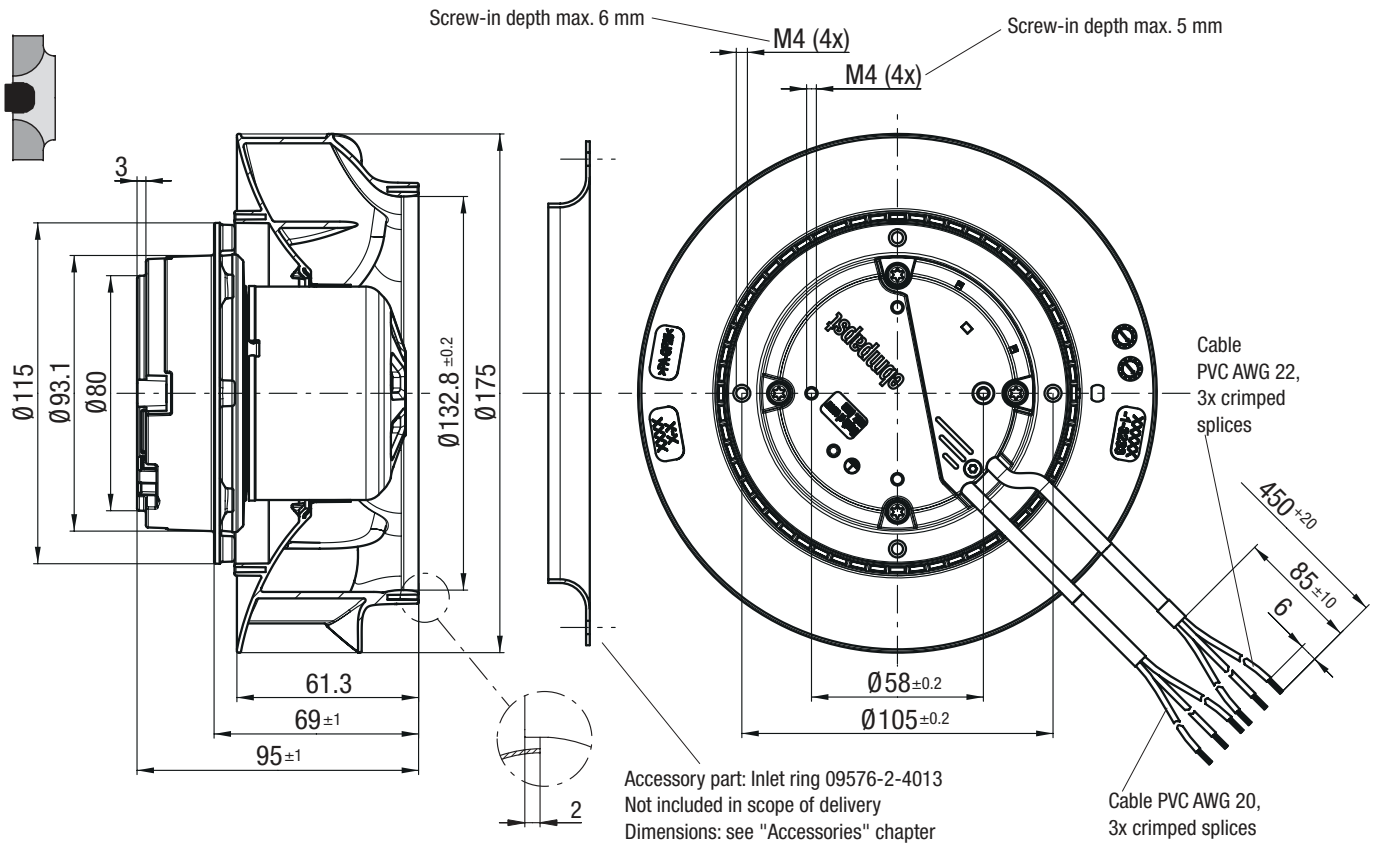

K1G 175-RF04-01 (Centrifugal module with support basket)

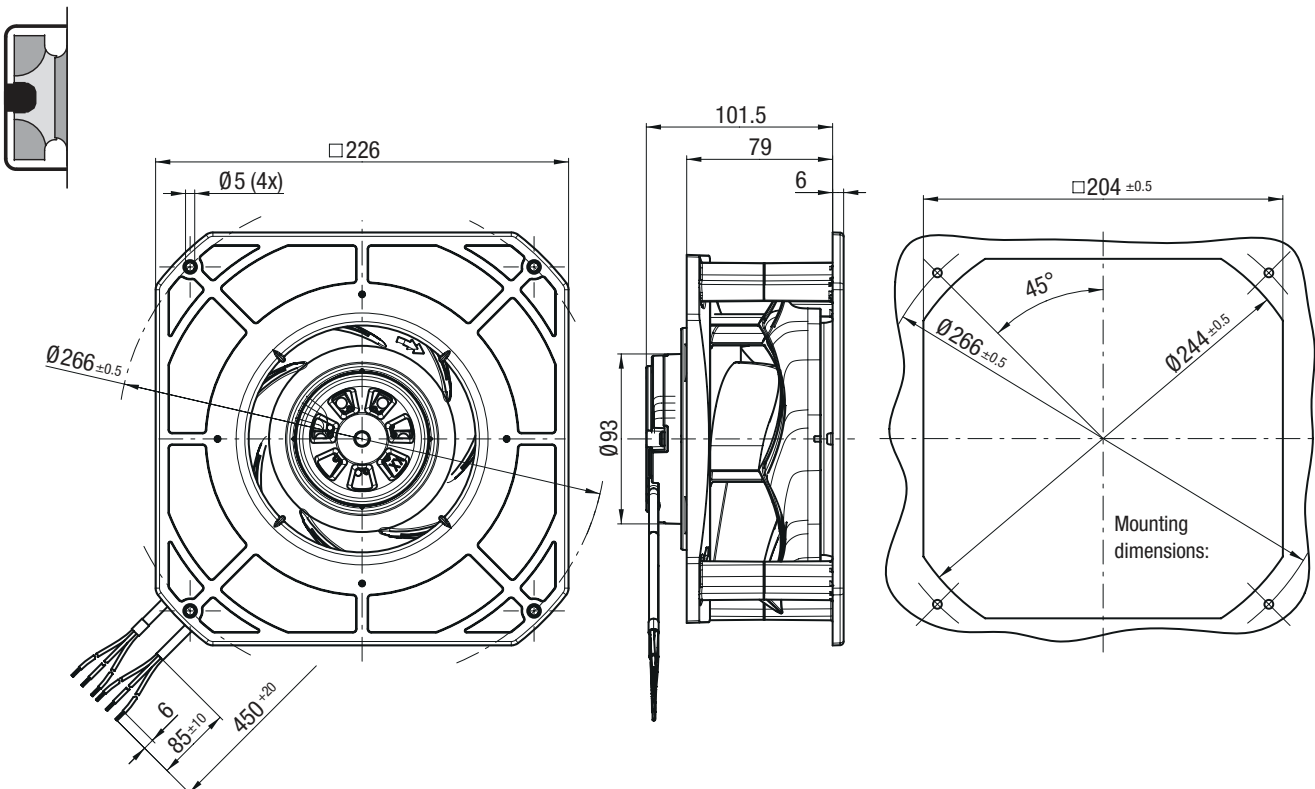

EC centrifugal fans – RadiCal

backward curved, Ø 190, Speed-controlled, 100 W - Electronics



R1G 190-RF04-01 (Centrifugal fan)

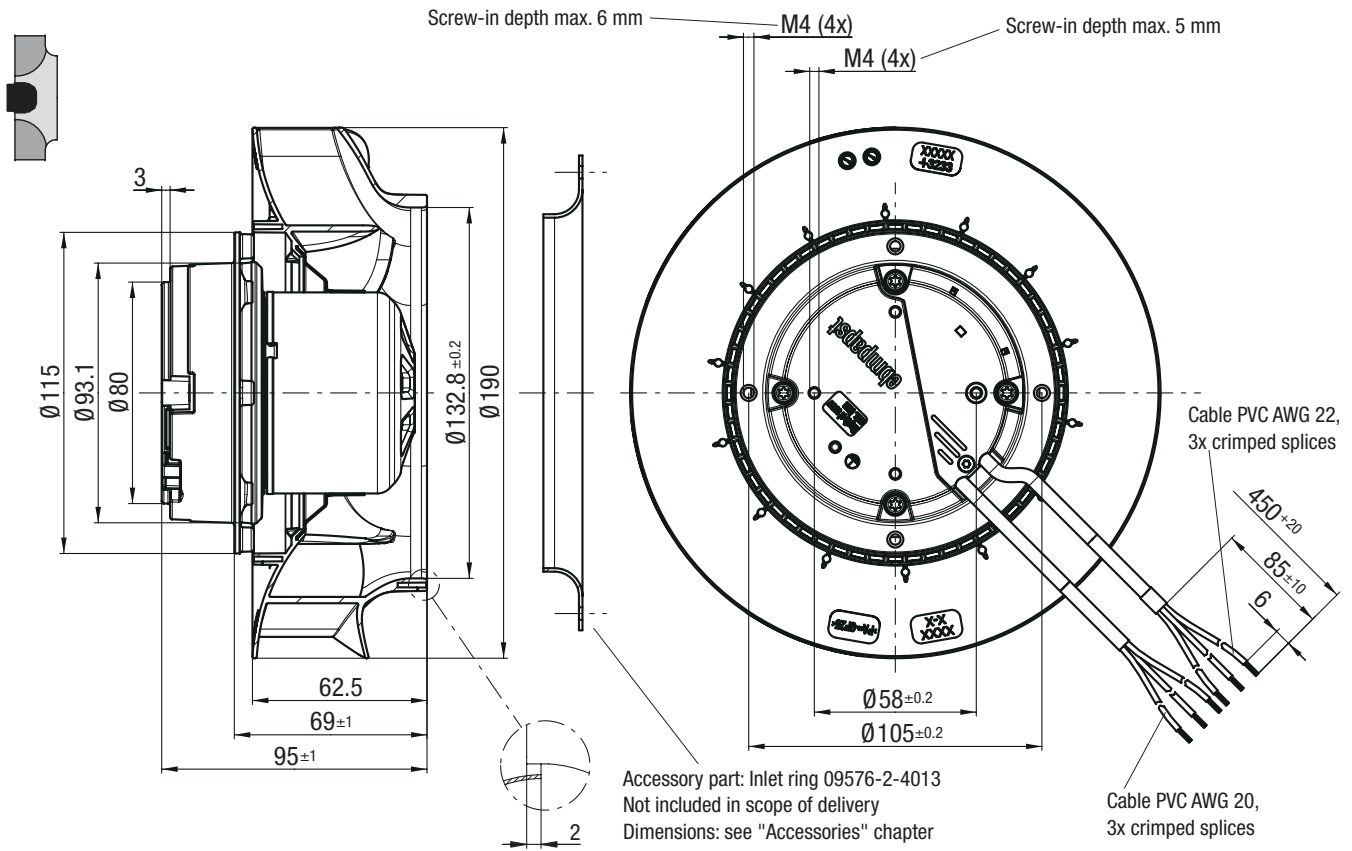

K1G 190-RF04-01 (Centrifugal module with support basket)

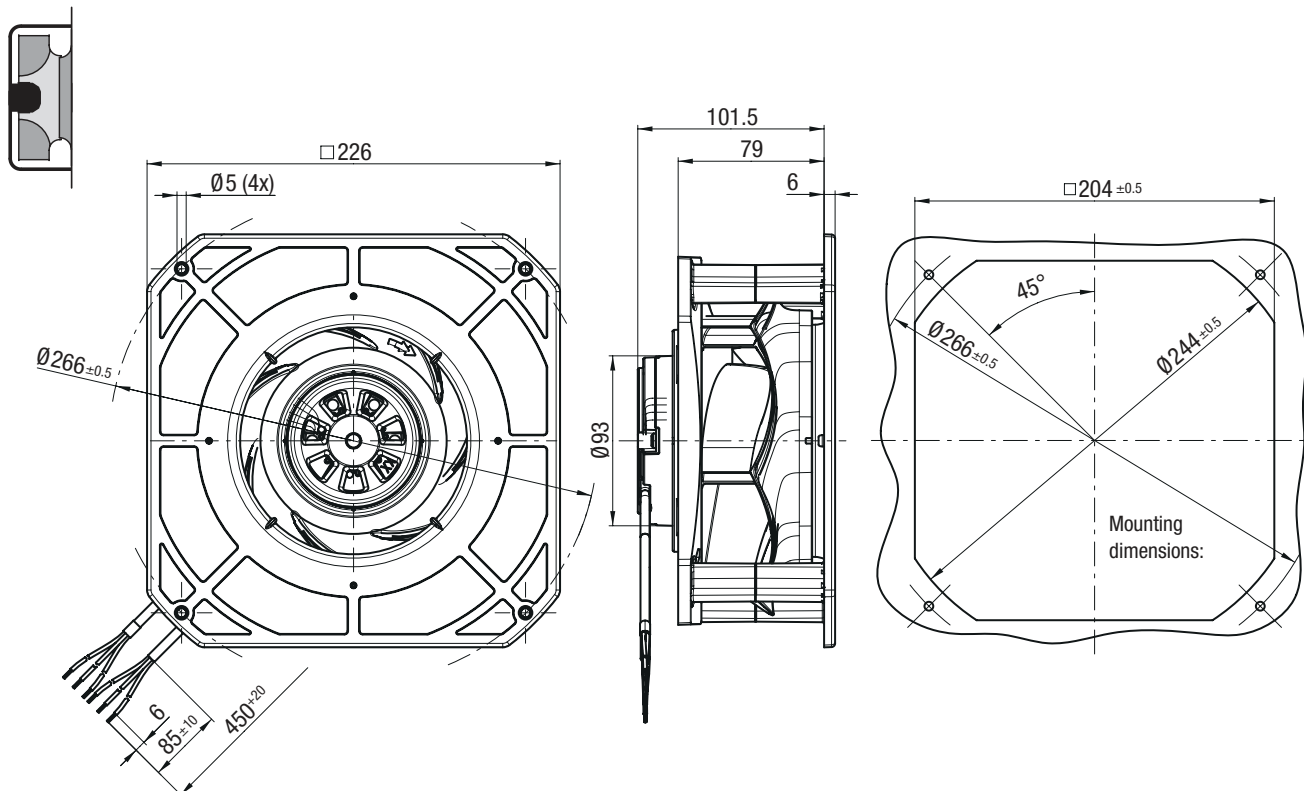

EC centrifugal fans – RadiCal

backward curved, Ø 220, Speed-controlled, 100 W - Electronics



R1G 220-RF01-01 (Centrifugal fan)

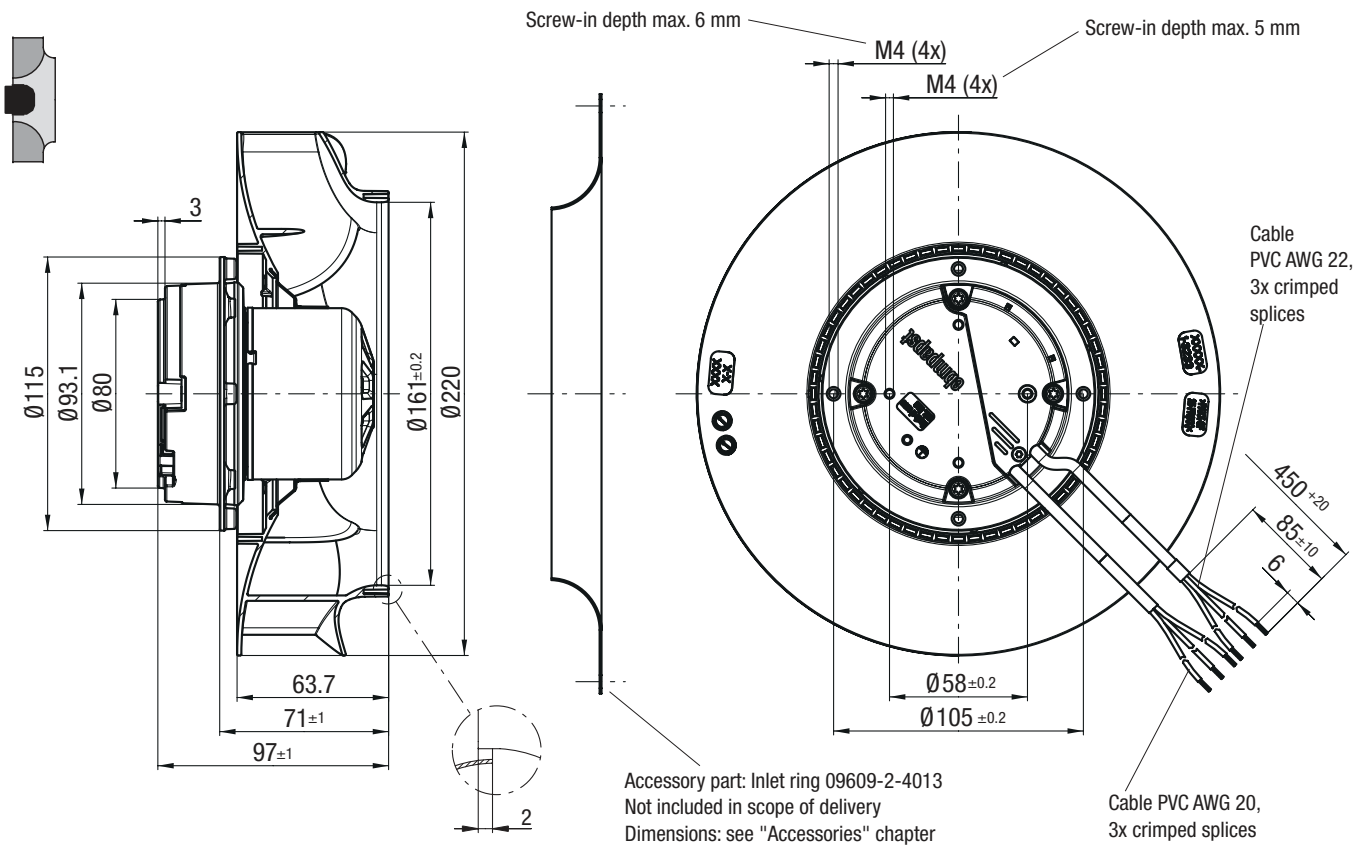

K1G 220-RF01-01 (Centrifugal module with support basket)

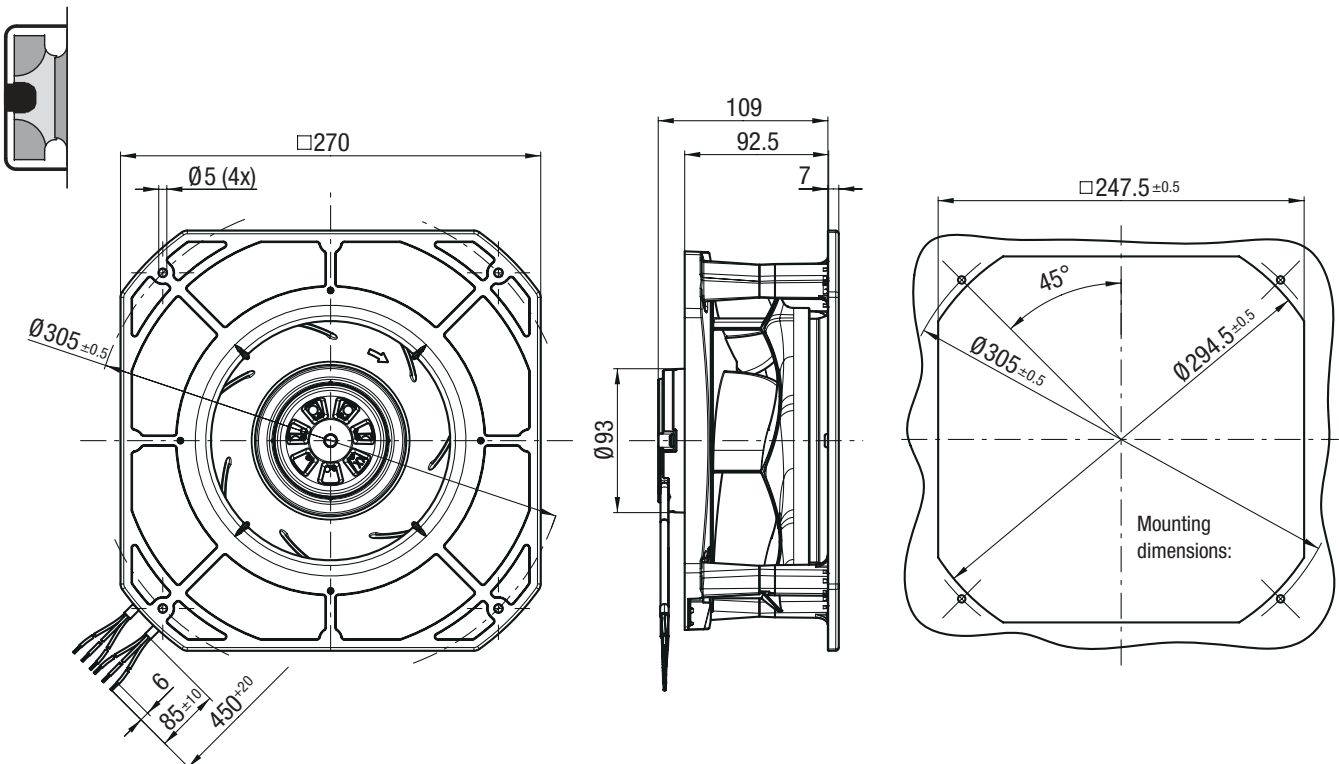

EC centrifugal fans – RadiCal

backward curved, Ø 225, Speed-controlled, 100 W - Electronics



R1G 225-RG04-01 (Centrifugal fan)

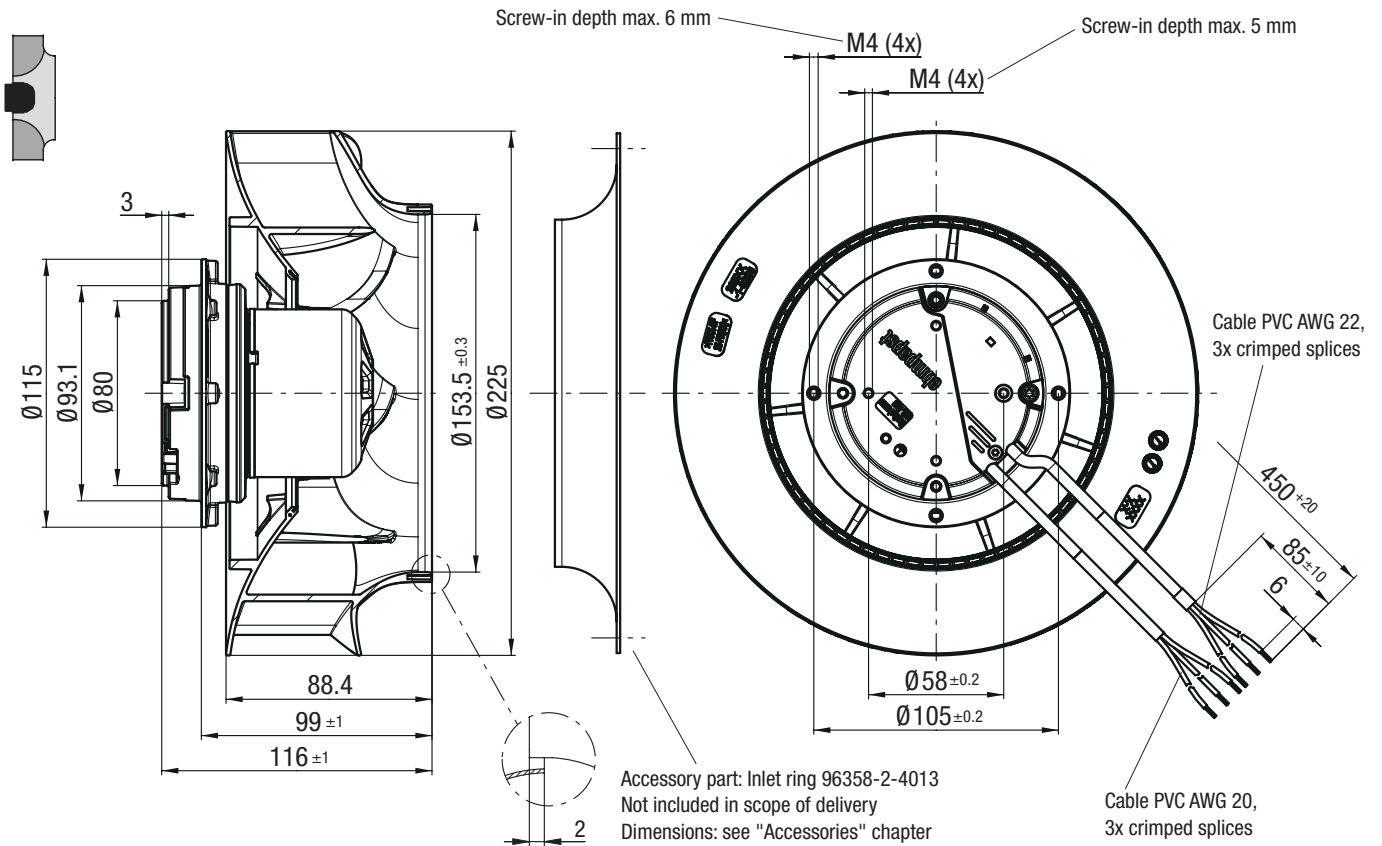

K1G 225-RG04-01 (Centrifugal module with support basket)

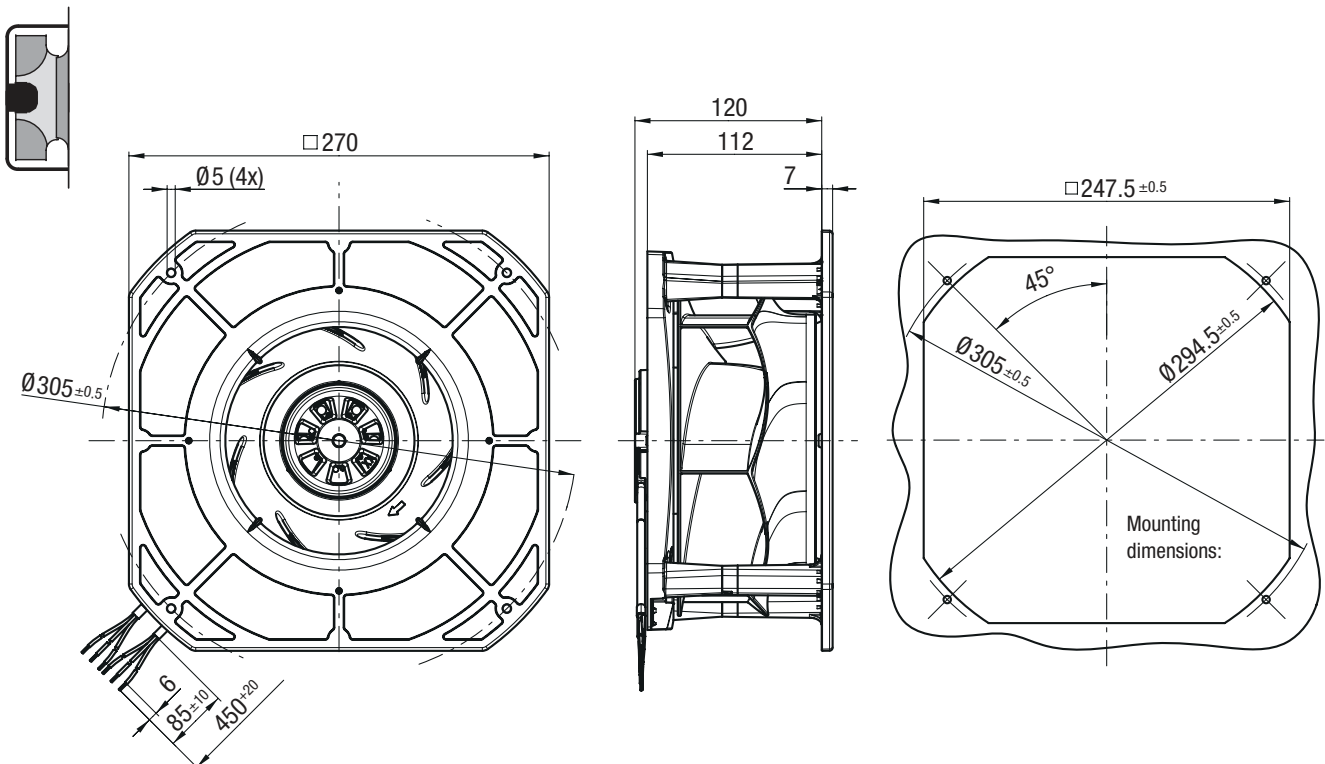

EC centrifugal fans – RadiCal

backward curved, Ø 250, Speed-controlled, 100 W - Electronics



R1G 250-RG01-01 (Centrifugal fan)

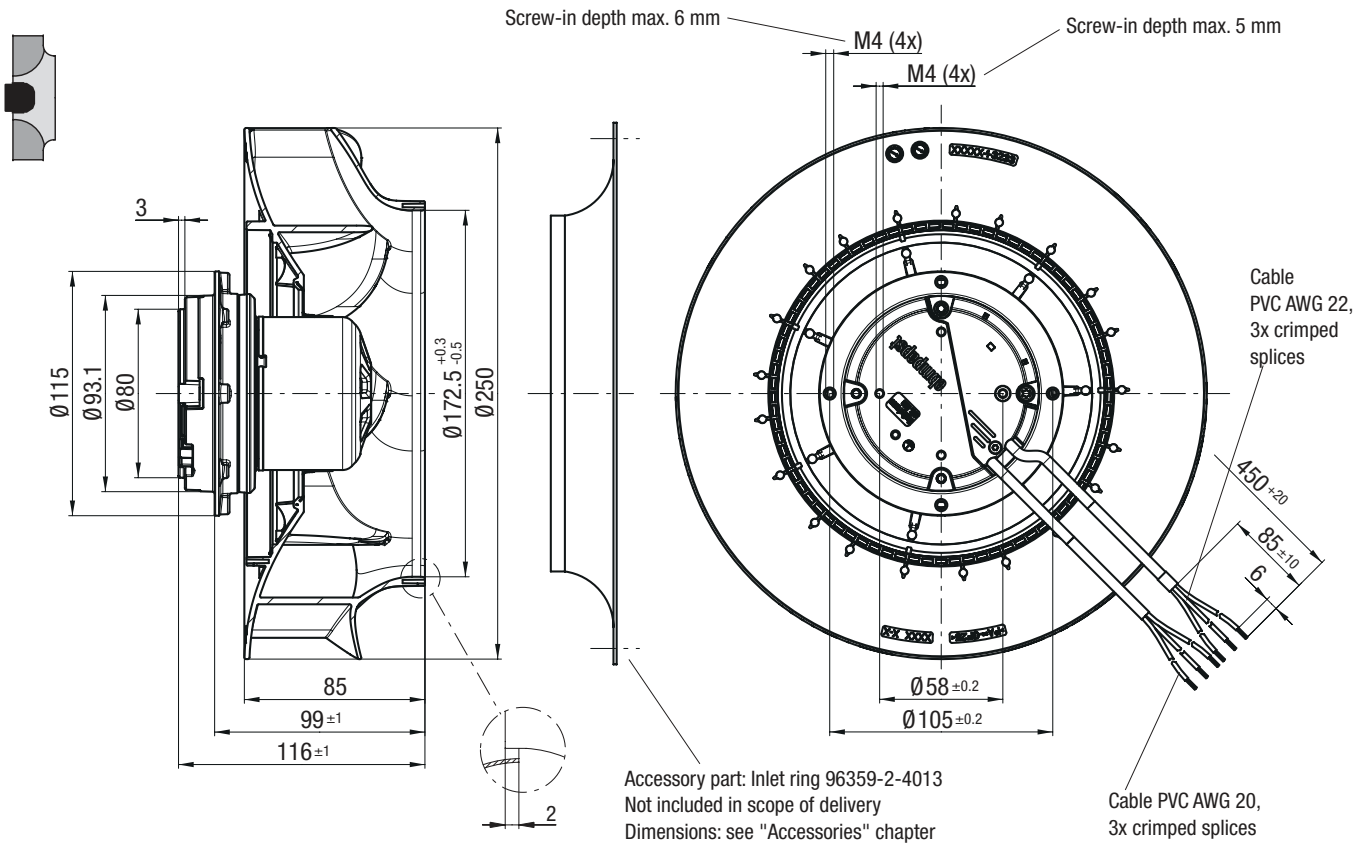

K1G 250-RG01-01 (Centrifugal module with support basket)

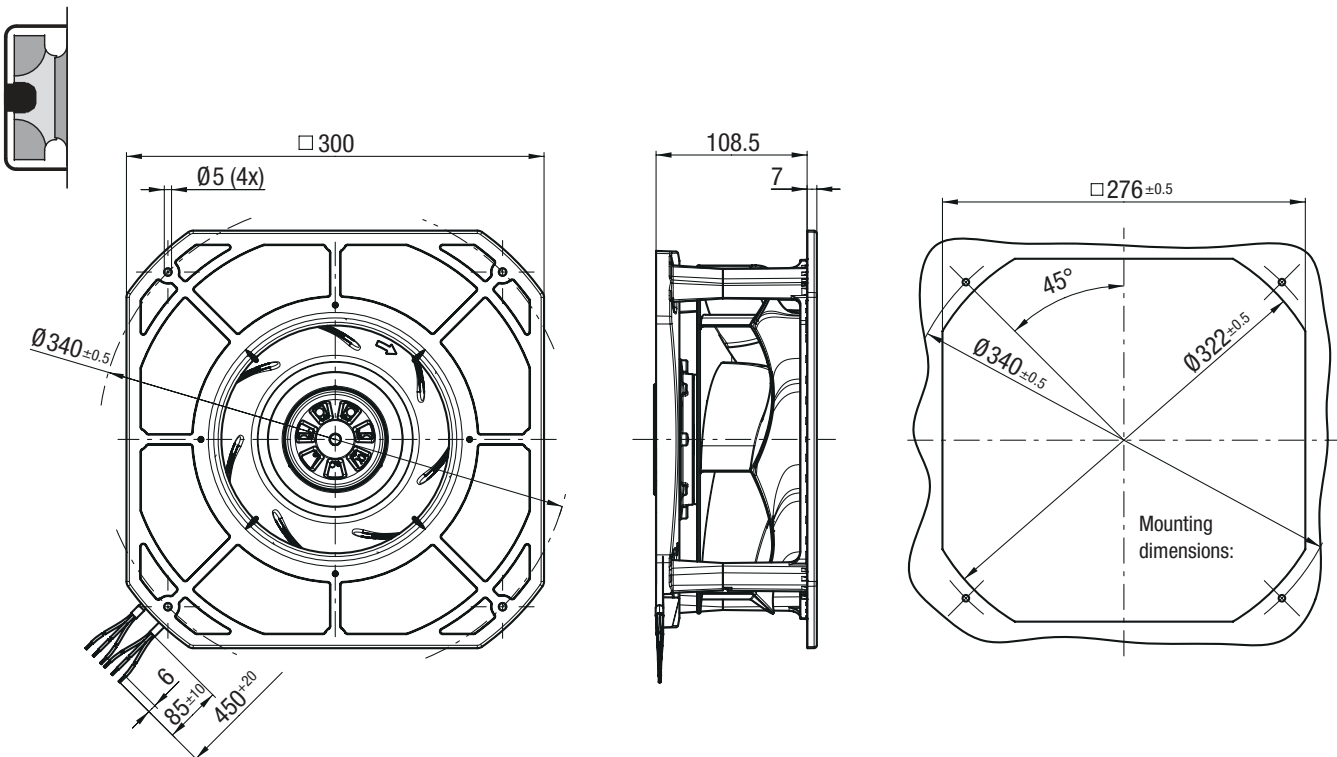

EC centrifugal fans – RadiCal

backward curved, Ø 250



- **Material:** Support bracket: Steel, painted black
Support plate and inlet ring: Sheet steel, galvanized
Impeller: Plastic
Rotor: Painted black
Electronics housing: Die-cast aluminium
- **Number of blades:** 7
- **Direction of rotation:** Clockwise viewed toward rotor
- **Degree of protection:** IP 55
- **Insulation class:** "F"
- **Installation position:** Shaft horizontal or rotor on bottom, rotor on top on request
- **Condensation drainage holes:** Rotor side
- **Mode:** Continuous operation (S1)
- **Mounting:** Maintenance-free ball bearings

Nominal data

| Type | Motor | Curve | Nominal voltage range | Frequency | Speed ⁽¹⁾ | Max. Input power ⁽¹⁾ | Max. Input current ⁽¹⁾ | Perm. ambient temp. | Techn. features and connection diagram |
|---------|------------|-------------|-----------------------|-----------|----------------------|---------------------------------|-----------------------------------|---------------------|--|
| Type | Motor | VAC | Hz | rpm | W | A | °C | | |
| *3G 250 | M3G 084-DF | Ⓐ 1~200-277 | 50/60 | 3740 | 500 | 2,20 | -25..+60 | P. 147 / RC4) | |
| *3G 250 | M3G 084-DF | Ⓑ 1~200-277 | 50/60 | 4250 | 750 | 3,30 | -25..+60 | P. 147 / RC4) | |

Subject to change

(1) Nominal data at operating point with maximum load and 230 VAC.

Curves:

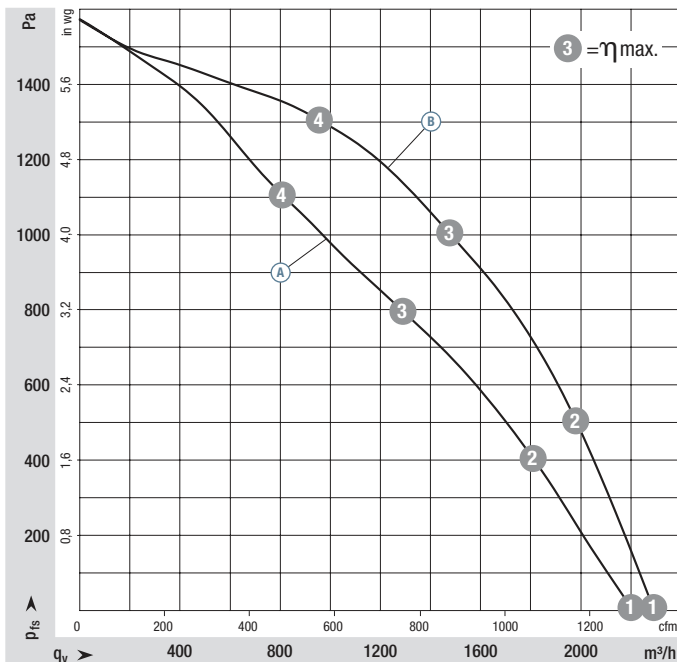

| | n rpm | P _{ed} W | I A | L _{wA} dB(A) |
|-----|-------|-------------------|------|-----------------------|
| Ⓐ 1 | 4100 | 500 | 2,20 | 89 |
| Ⓐ 2 | 3865 | 500 | 2,20 | 83 |
| Ⓐ 3 | 3740 | 500 | 2,20 | 78 |
| Ⓐ 4 | 3890 | 500 | 2,20 | 85 |
| Ⓑ 1 | 4250 | 586 | 2,61 | 90 |
| Ⓑ 2 | 4250 | 691 | 3,04 | 86 |
| Ⓑ 3 | 4250 | 750 | 3,30 | 81 |
| Ⓑ 4 | 4250 | 663 | 2,92 | 85 |

Air performance measured according to: ISO 5801, installation category A, with ebm-papst inlet ring without contact protection. Intake-side sound level: L_{wA} according to ISO 13347, L_{pA} measured at 1 m distance from fan axis. The values given are only applicable under the specified measuring conditions and may differ depending on the installation conditions. In the event of deviation from the standard configuration, the parameters must be checked in installed condition. See Page 162 ff. for detailed information.

- **Technical features:** See connection diagram P. 147
- **EMC:** Interference emission according to EN 61000-6-3
Immunity to interference according to EN 61000-6-2
Circuit feedback according to EN 61000-3-2/3
- **Touch current:** < 3,5 mA according to IEC 60990 (measuring circuit Fig. 4)
- **Cable exit:** Variable
- **Protection class:** I (with customer connection of protective earth)
- **Conformity with standards:** EN 60335-1, EN 61800-5-1, CE
- **Approvals:** VDE, UL, CSA, CCC, EAC
- **Efficiency:** Ecodesign EU regulation EU 327/2011



Weight
Centrifugal fan



Weight Centrifugal
module with
support bracket

| Centrifugal fan | kg | Centrifugal module with support bracket | kg |
|------------------|------|---|------|
| R3G 250-RR01 -H1 | 3,90 | K3G 250-RR01 -H2 | 7,90 |
| R3G 250-RR02 -I1 | 4,40 | K3G 250-RR02 -I2 | 8,50 |

EC centrifugal fans – RadiCal

backward curved, Ø 250



R3G 250-RR01-H1 (Centrifugal fan)

Accessory part: Inlet ring 96359-2-4013
Not included in scope of delivery
Dimensions: see "Accessories" chapter

Screw-in depth max. 16 mm

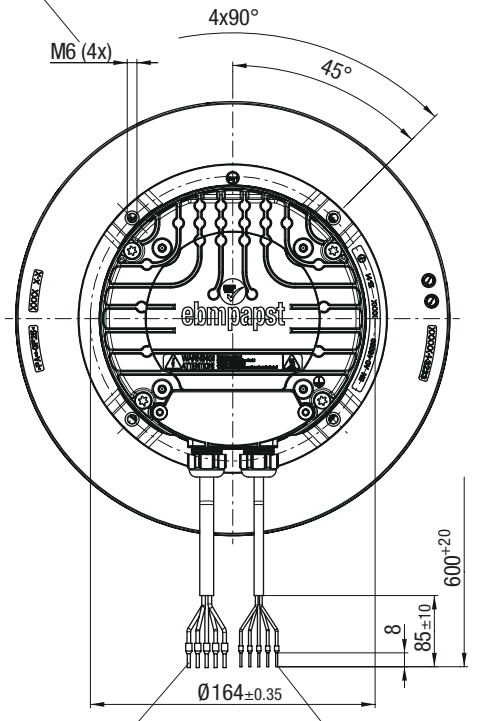
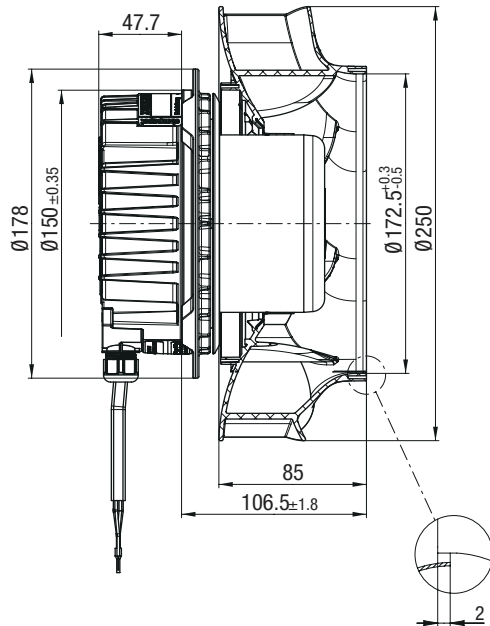

Cable AWG 18,
5x crimped ferrules

Cable AWG 22,
5x crimped ferrules

K3G 250-RR01-H2 (Centrifugal module with support bracket)

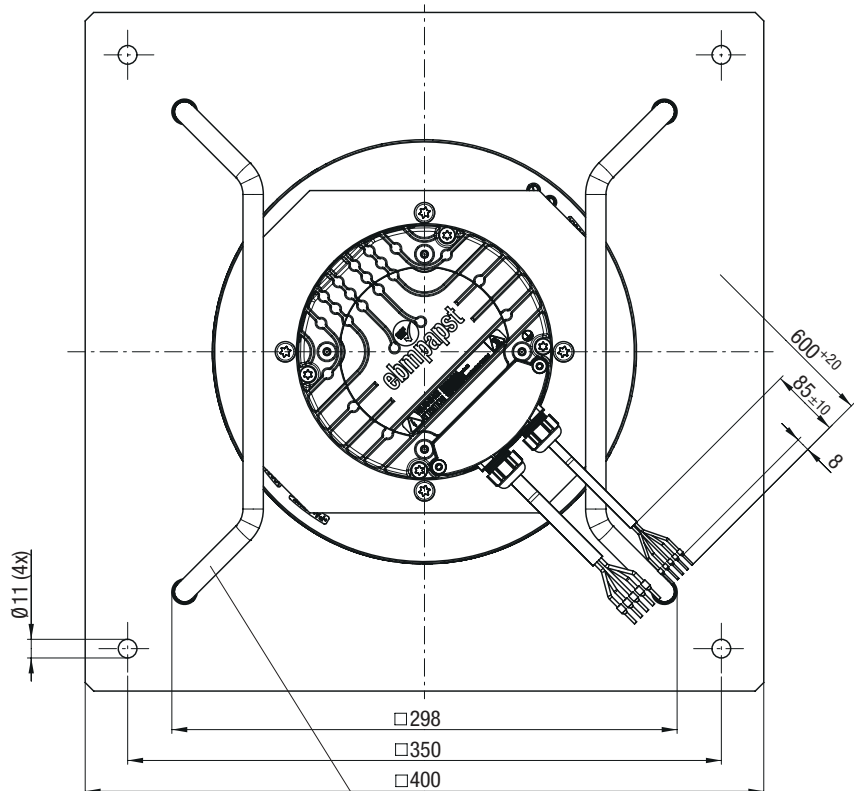
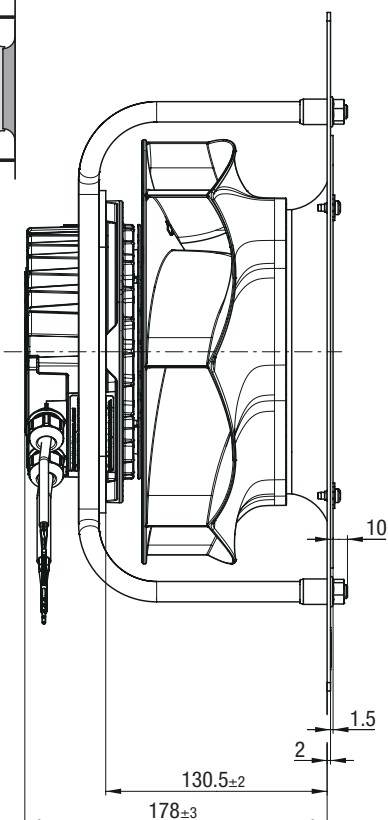

Note installed position! Install support struts as illustrated

EC centrifugal fans – RadiCal

backward curved, Ø 250



R3G 250-RR02-I1 (Centrifugal fan)

Accessory part: Inlet ring 96359-2-4013
Not included in scope of delivery
Dimensions: see "Accessories" chapter

Screw-in depth max. 16 mm

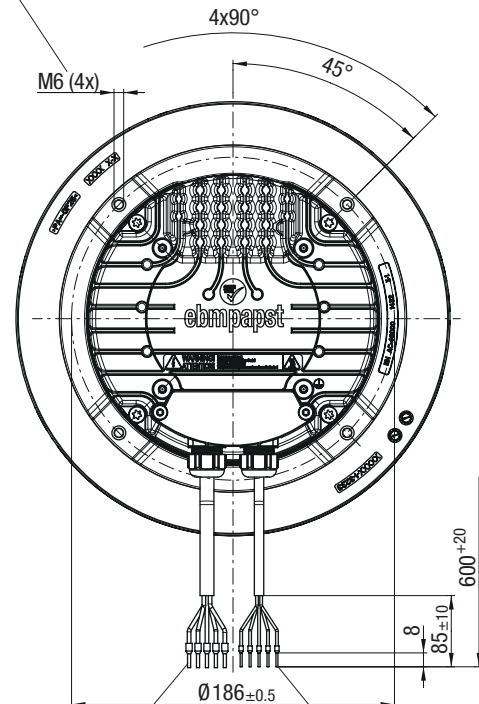
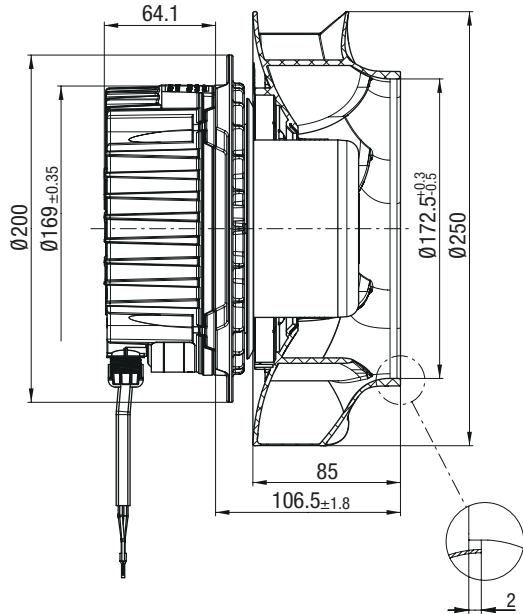

Cable AWG 18,
5x crimped ferrules

Cable AWG 22,
5x crimped ferrules

K3G 250-RR02-I2 (Centrifugal module with support bracket)

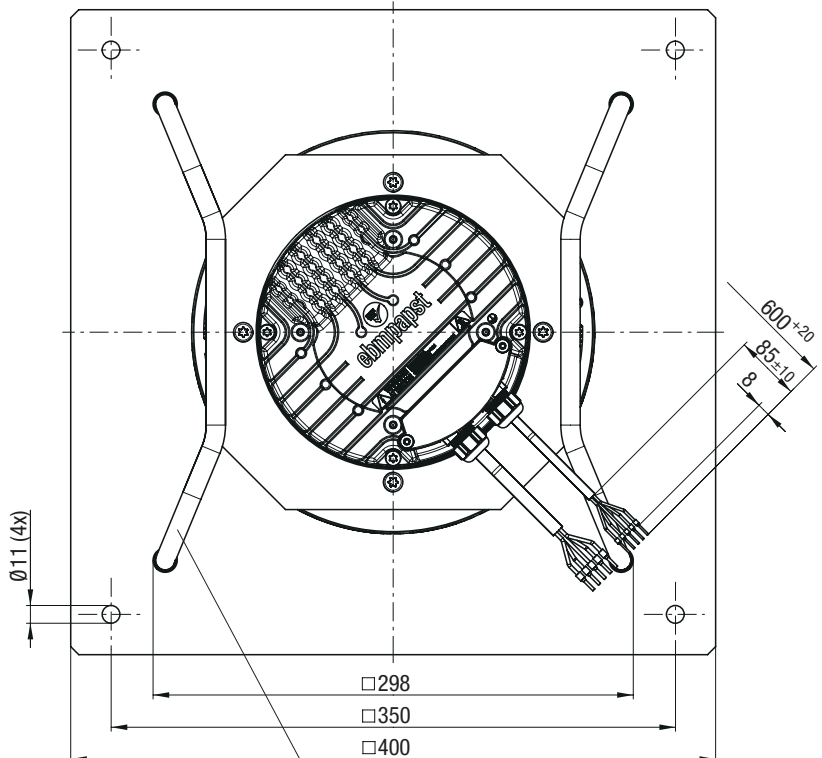
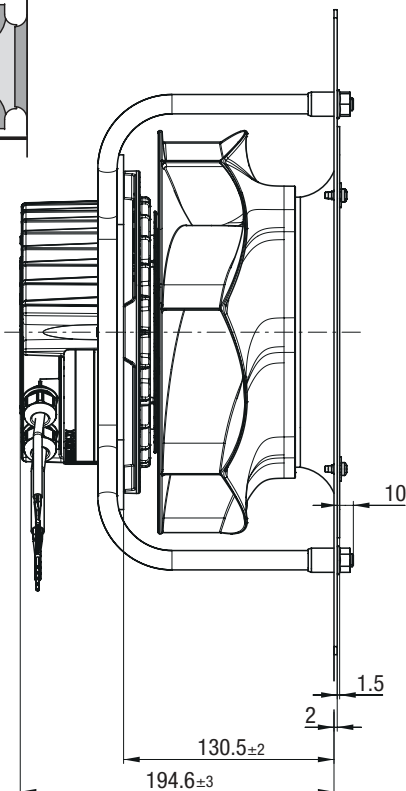

Note installed position! Install support struts as illustrated

EC centrifugal fans – RadiCal

backward curved, Ø 280



- **Material:** Support bracket: Steel, painted black
Support plate and inlet ring: Sheet steel, galvanized
Impeller: Plastic
Rotor: (A) Surface passivated, (B) (C) Painted black
Electronics housing: Die-cast aluminium
- **Number of blades:** 6
- **Direction of rotation:** Clockwise viewed toward rotor
- **Degree of protection:** (A) IP 54, (B) (C) IP 55
- **Insulation class:** (A) "B", (B) (C) "F"
- **Installation position:** (A) Any
(B) (C) Shaft horizontal or rotor on bottom, rotor on top on request
- **Condensation drainage holes:** (A) None, open rotor, (B) (C) Rotor side
- **Mode:** Continuous operation (S1)
- **Mounting:** Maintenance-free ball bearings

Nominal data

| Type | Motor | Curve | Nominal voltage range | Frequency | Speed ⁽¹⁾ | Max. Input power ⁽¹⁾ | Max. Input current ⁽¹⁾ | Perm. ambient temp. | Techn. features and connection diagram |
|---------|------------|---------------|-----------------------|-----------|----------------------|---------------------------------|-----------------------------------|---------------------|--|
| Type | Motor | VAC | Hz | rpm | W | A | °C | | |
| *3G 280 | M3G 074-CF | (A) 1~200-240 | 50/60 | 1910 | 168 | 1,40 | -25..+60 | P. 146 / RC3) | |
| *3G 280 | M3G 084-DF | (B) 1~200-277 | 50/60 | 2700 | 500 | 2,20 | -25..+60 | P. 147 / RC4) | |
| *3G 280 | M3G 084-DF | (C) 1~200-277 | 50/60 | 2900 | 660 | 2,90 | -25..+60 | P. 147 / RC4) | |

Subject to change

(1) Nominal data at operating point with maximum load and 230 VAC.

Curves:

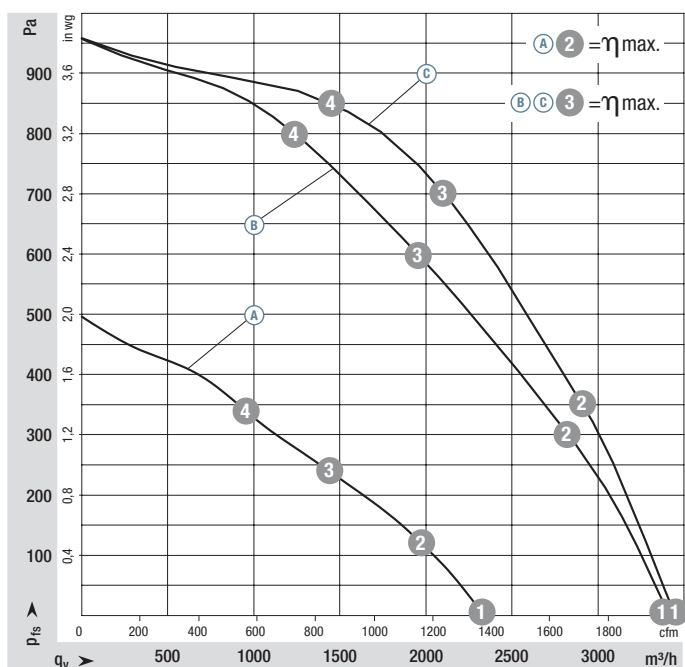

| | n rpm | P _{ed} W | I A | L _{wA} dB(A) |
|-------|-------|-------------------|------|-----------------------|
| (A) 1 | 1980 | 152 | 1,05 | 75 |
| (A) 2 | 1910 | 168 | 1,40 | 69 |
| (A) 3 | 1775 | 165 | 1,30 | 63 |
| (A) 4 | 1860 | 166 | 1,30 | 64 |
| (B) 1 | 2885 | 460 | 2,01 | 85 |
| (B) 2 | 2795 | 500 | 2,20 | 80 |
| (B) 3 | 2700 | 500 | 2,20 | 73 |
| (B) 4 | 2840 | 500 | 2,20 | 79 |
| (C) 1 | 2900 | 487 | 2,18 | 86 |
| (C) 2 | 2900 | 604 | 2,67 | 81 |
| (C) 3 | 2900 | 660 | 2,90 | 76 |
| (C) 4 | 2900 | 571 | 2,53 | 81 |

Air performance measured according to: ISO 5801, installation category A, with ebm-papst inlet ring without contact protection. Intake-side sound level: L_{wA} according to ISO 13347, L_{pA} measured at 1 m distance from fan axis. The values given are only applicable under the specified measuring conditions and may differ depending on the installation conditions. In the event of deviation from the standard configuration, the parameters must be checked in installed condition. See Page 162 ff. for detailed information.

- **Technical features:** See connection diagram P. 146 f.
- **EMC:** Interference emission according to EN 61000-6-3
Immunity to interference according to EN 61000-6-2
Circuit feedback according to EN 61000-3-2/3
Ⓐ On account of the installation conditions, ferritic damping in the connection line may be required for the application.
- **Touch current:** < 3,5 mA according to IEC 60990 (measuring circuit Fig. 4)
- **Cable exit:** Variable
- **Protection class:** I (with customer connection of protective earth)
- **Conformity with standards:** Ⓐ EN 60335-1, CE; Ⓑ Ⓒ EN 60335-1, EN 61800-5-1, CE
- **Approvals:** Ⓐ VDE, CURUS on request; Ⓑ Ⓒ VDE, UL, CSA, CCC, EAC
- **Efficiency:** Ecodesign EU regulation EU 327/2011



Weight
Centrifugal fan



Weight Centrifugal
module with
support bracket

| Centrifugal fan | kg | Centrifugal module with support bracket | kg |
|------------------|------|---|------|
| R3G 280-RB02 -03 | 2,70 | K3G 280-RB02 -03 | 6,80 |
| R3G 280-RR03 -H1 | 4,20 | K3G 280-RR03 -H2 | 8,30 |
| R3G 280-RR04 -I1 | 4,60 | K3G 280-RR04 -I2 | 8,80 |

EC centrifugal fans – RadiCal

backward curved, Ø 280



R3G 280-RB02-03 (Centrifugal fan)

Accessory part: Inlet ring 28000-2-4013
Not included in scope of delivery. Dimensions: see "Accessories" chapter

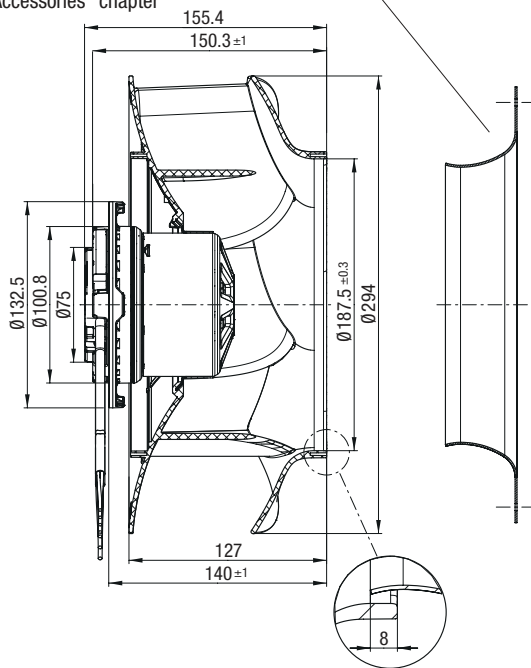

Screw-in depth max. 10 mm Screw-in depth max. 5 mm

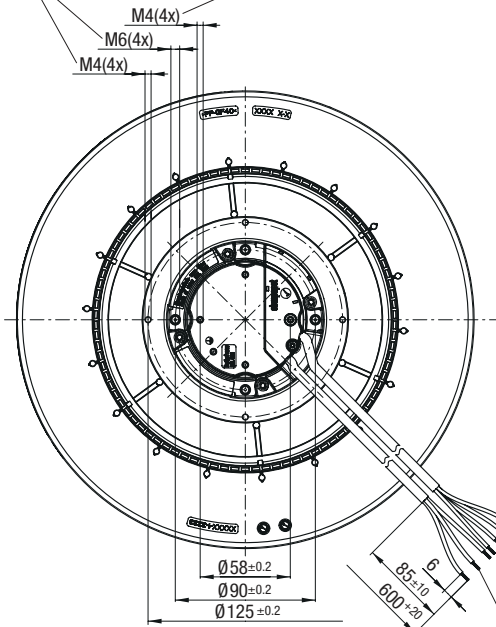

Cable AWG 20,
3x crimped splices

Cable AWG 22,
4x crimped splices

K3G 280-RB02-03 (Centrifugal module with support bracket)

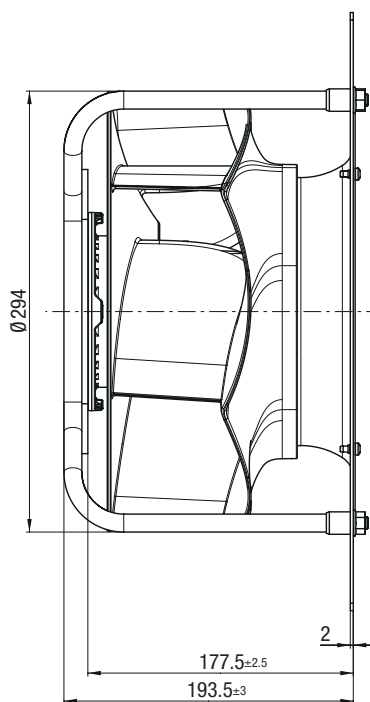

Note installed position! Install support struts as illustrated

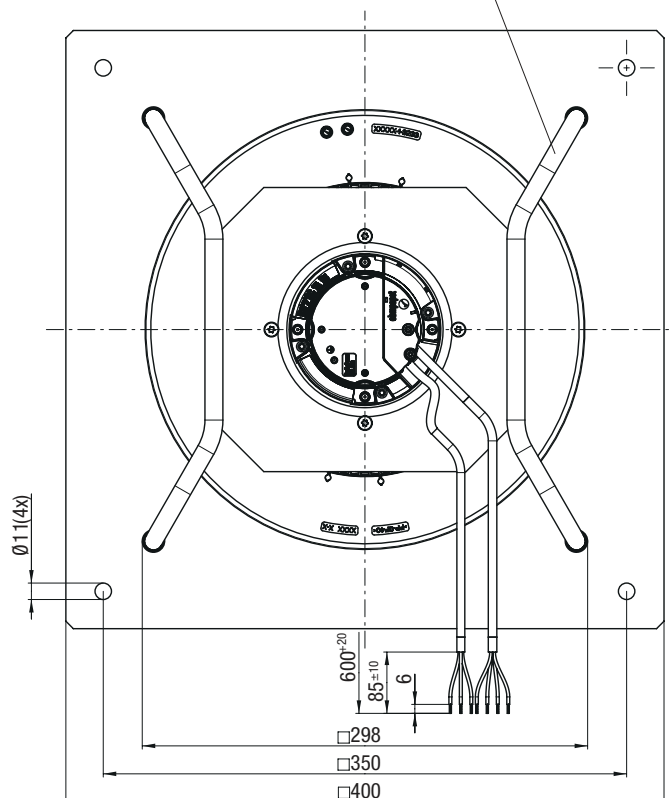

EC centrifugal fans – RadiCal

backward curved, Ø 280



R3G 280-RR03-H1 (Centrifugal fan)

Accessory part: Inlet ring 28000-2-4013
Not included in scope of delivery
Dimensions: see "Accessories" chapter

Screw-in depth max. 16 mm

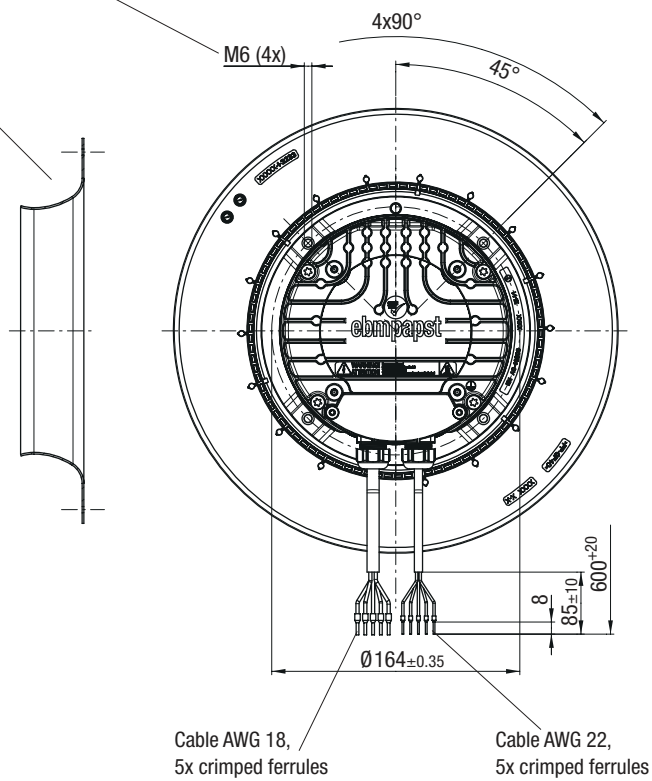
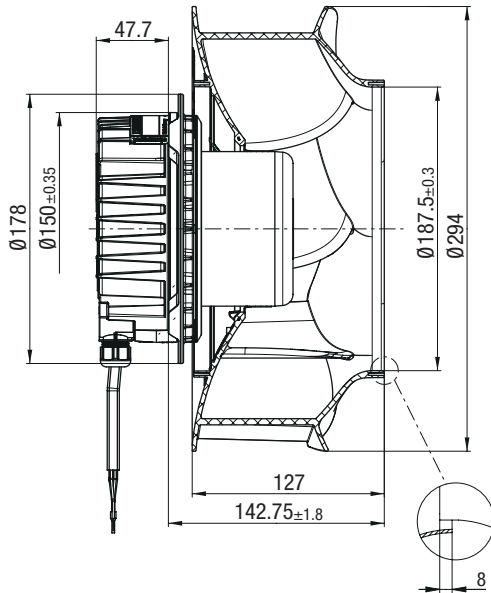

K3G 280-RR03-H2 (Centrifugal module with support bracket)

Note installed position! Install support struts as illustrated

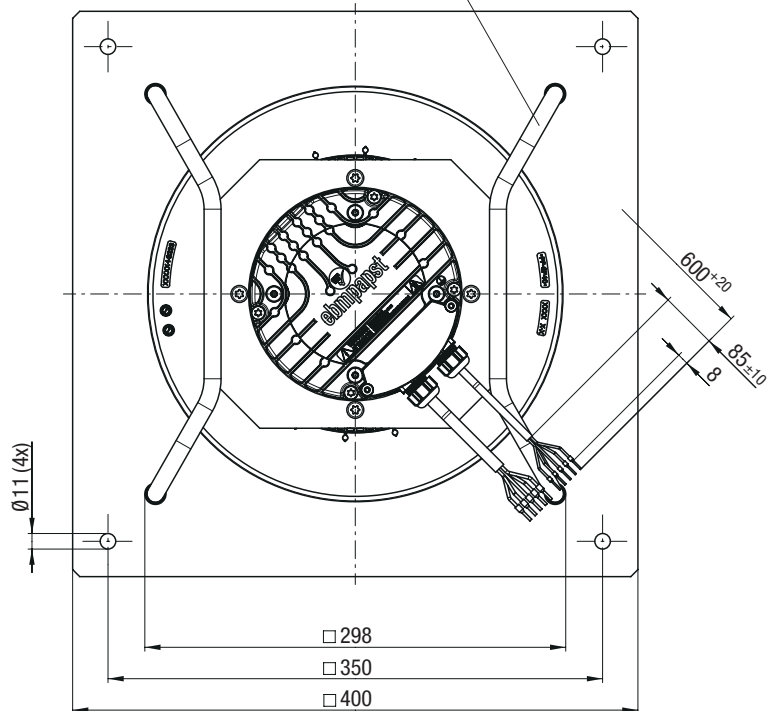
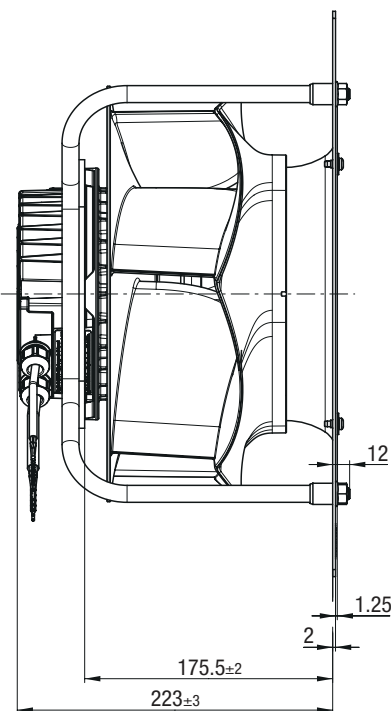

EC centrifugal fans – RadiCal

backward curved, Ø 280



R3G 280-RR04-I1 (Centrifugal fan)

Accessory part: Inlet ring 28000-2-4013
Not included in scope of delivery
Dimensions: see "Accessories" chapter

Screw-in depth max. 16 mm

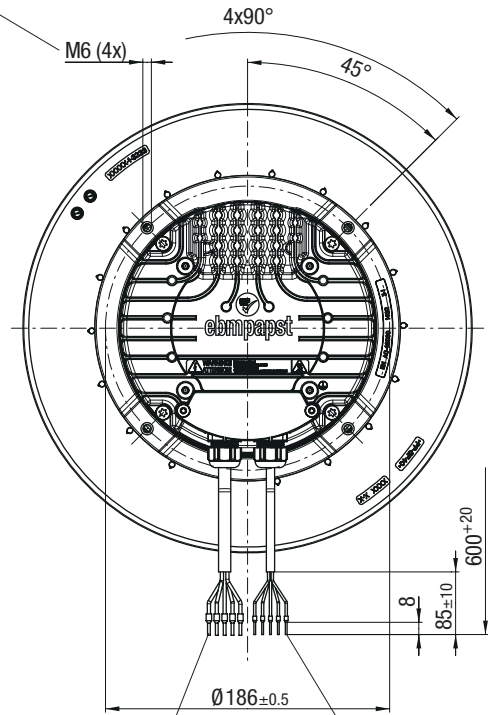
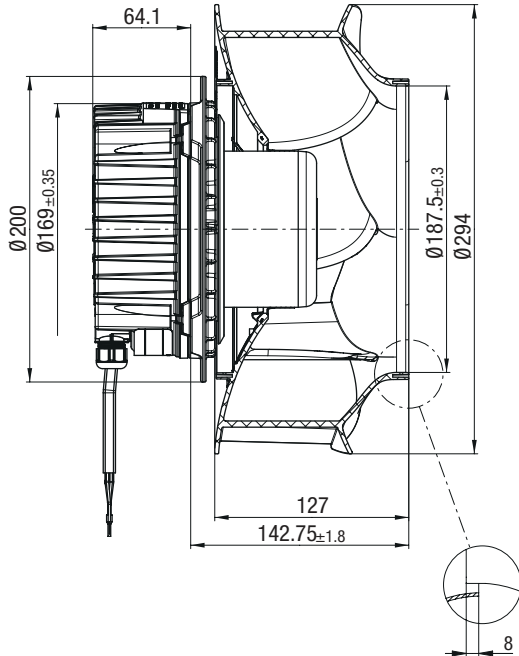

Cable AWG 18,
5x crimped ferrules

Cable AWG 22,
5x crimped ferrules

K3G 280-RR04-I2 (Centrifugal module with support bracket)

Note installed position! Install support struts as illustrated

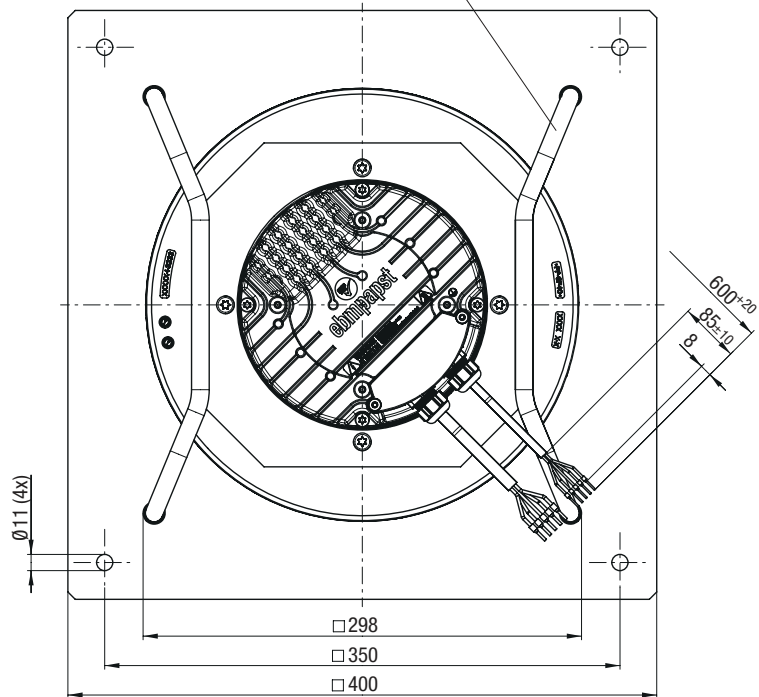
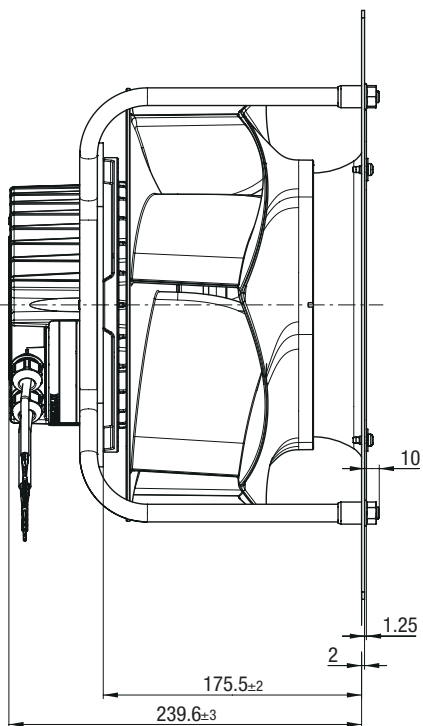

EC centrifugal fans – RadiCal

backward curved, Ø 310



- **Material:** Support bracket: Steel, painted black
Support plate and inlet ring: Sheet steel, galvanized
Impeller: Plastic
Rotor: (A) Surface passivated, (B) (C) (D) Painted black
Electronics housing: Die-cast aluminium
- **Number of blades:** 6
- **Direction of rotation:** Clockwise viewed toward rotor
- **Degree of protection:** (A) IP 54, (B) (C) (D) IP 55
- **Insulation class:** (A) "B", (B) (C) (D) "F"
- **Installation position:** (A) Any,
(B) (C) (D) Shaft horizontal or rotor on bottom, rotor on top on request
- **Condensation drainage holes:** (A) None, open rotor (B) (C) (D) Rotor side
- **Mode:** Continuous operation (S1)
- **Mounting:** Maintenance-free ball bearings

Nominal data

| Type | Motor | Curve | Nominal voltage range | Frequency | Speed ⁽¹⁾ | Max. Input power ⁽¹⁾ | Max. Input current ⁽¹⁾ | Perm. ambient temp. | Techn. features and connection diagram |
|---------|------------|---------------|-----------------------|-----------|----------------------|---------------------------------|-----------------------------------|---------------------|--|
| Type | Motor | VAC | Hz | rpm | W | A | °C | | |
| *3G 310 | M3G 074-CF | (A) 1~200-240 | 50/60 | 1525 | 150 | 1,20 | -25..+60 | P. 146 / RC3) | |
| *3G 310 | M3G 084-DF | (B) 1~200-277 | 50/60 | 2360 | 500 | 2,20 | -25..+60 | P. 147 / RC4) | |
| *3G 310 | M3G 084-FA | (C) 1~200-277 | 50/60 | 2640 | 730 | 3,20 | -25..+60 | P. 147 / RC4) | |
| *3G 310 | M3G 084-FA | (D) 3~380-480 | 50/60 | 2700 | 790 | 1,25 | -25..+60 | P. 148 / RC5) | |

Subject to change

(1) Nominal data at operating point with maximum load and 230 or 400 VAC.

Curves:

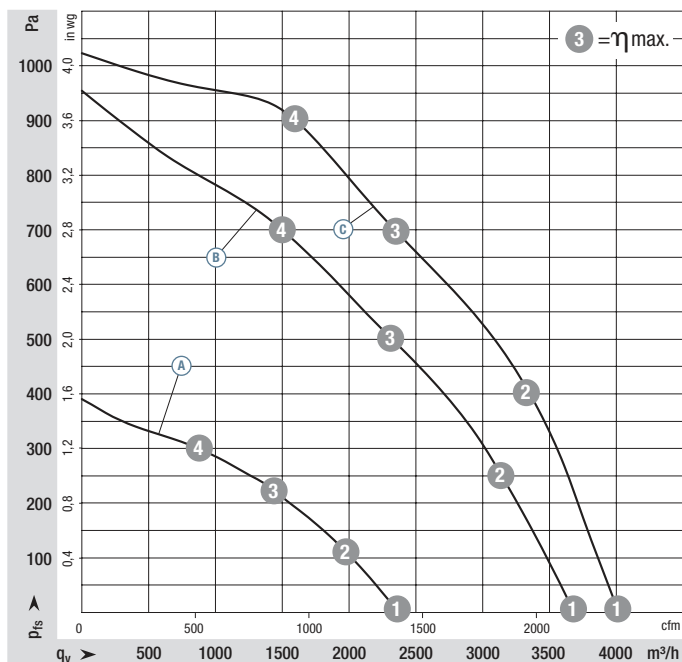

| | n rpm | P _{ed} W | I A | L _{wA} dB(A) |
|-------|-------|-------------------|------|-----------------------|
| (A) 1 | 1600 | 115 | 0,95 | 69 |
| (A) 2 | 1545 | 137 | 1,12 | 65 |
| (A) 3 | 1525 | 150 | 1,20 | 59 |
| (A) 4 | 1545 | 137 | 1,13 | 62 |
| (B) 1 | 2510 | 431 | 1,88 | 81 |
| (B) 2 | 2435 | 500 | 2,20 | 76 |
| (B) 3 | 2360 | 500 | 2,20 | 72 |
| (B) 4 | 2435 | 500 | 2,20 | 78 |
| (C) 1 | 2700 | 550 | 2,45 | 84 |
| (C) 2 | 2700 | 729 | 3,20 | 79 |
| (C) 3 | 2640 | 730 | 3,20 | 75 |
| (C) 4 | 2700 | 730 | 3,20 | 79 |

Air performance measured according to: ISO 5801, installation category A, with ebm-papst inlet ring without contact protection. Intake-side sound level: L_{wA} according to ISO 13347, L_{pA} measured at 1 m distance from fan axis. The values given are only applicable under the specified measuring conditions and may differ depending on the installation conditions. In the event of deviation from the standard configuration, the parameters must be checked in installed condition. See Page 162 ff. for detailed information.

- **Technical features:** See connection diagram P. 146 ff.
- **EMC:** Interference emission according to EN 61000-6-3
Immunity to interference according to EN 61000-6-2
Circuit feedback according to EN 61000-3-2/3
Ⓐ On account of the installation conditions, ferritic damping in the connection line may be required for the application.
- **Touch current:** < 3,5 mA according to IEC 60990 (measuring circuit Fig. 4)
- **Cable exit:** Variable
- **Protection class:** I (with customer connection of protective earth)
- **Conformity with standards:** Ⓐ EN 60335-1, CE; Ⓑ Ⓒ EN 60335-1, EN 61800-5-1, CE; Ⓓ EN 61800-5-1, CE
- **Approvals:** Ⓐ VDE, CURUS on request; Ⓑ Ⓒ Ⓓ VDE, UL, CSA, CCC, EAC
- **Efficiency:** Ecodesign EU regulation EU 327/2011



Weight Centrifugal fan



Weight Centrifugal module with support bracket

| Centrifugal fan | kg | Centrifugal module with support bracket | kg |
|------------------|------|---|------|
| R3G 310-RB01 -03 | 2,90 | K3G 310-RB01 -03 | 7,50 |
| R3G 310-RR05 -H1 | 4,60 | K3G 310-RR05 -H2 | 9,50 |
| R3G 310-RS01 -I1 | 5,70 | K3G 310-RS01 -I2 | 10,7 |
| R3G 310-RS05 -J1 | 5,50 | K3G 310-RS05 -J2 | 11,3 |

Curves:

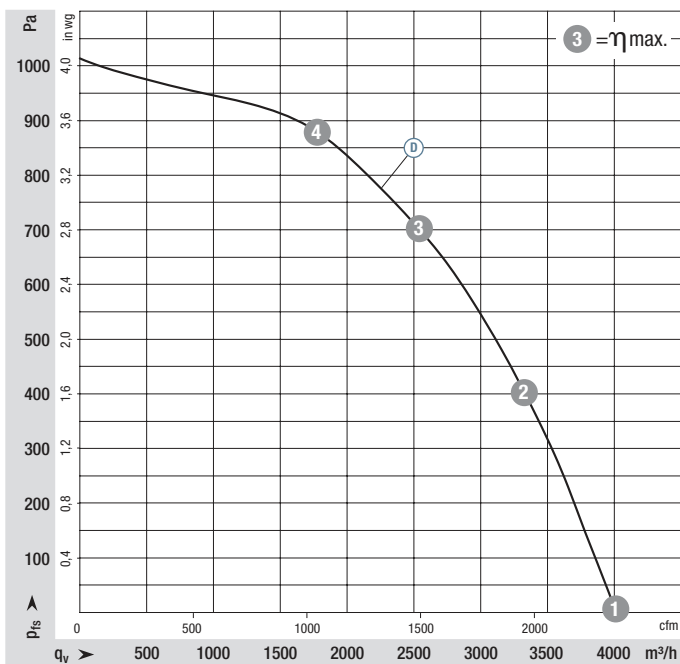

| | n rpm | P _{ed} W | I A | L _{wA} dB(A) |
|-----|-------|-------------------|------|-----------------------|
| Ⓓ 1 | 2700 | 557 | 0,89 | 84 |
| Ⓓ 2 | 2700 | 723 | 1,14 | 79 |
| Ⓓ 3 | 2700 | 790 | 1,25 | 76 |
| Ⓓ 4 | 2700 | 744 | 1,17 | 79 |

Air performance measured according to: ISO 5801, installation category A, with ebm-papst inlet ring without contact protection. Intake-side sound level: L_{wA} according to ISO 13347, L_{pA} measured at 1 m distance from fan axis. The values given are only applicable under the specified measuring conditions and may differ depending on the installation conditions. In the event of deviation from the standard configuration, the parameters must be checked in installed condition. See Page 162 ff. for detailed information.

EC centrifugal fans – RadiCal

backward curved, Ø 310



R3G 310-RB01-03 (Centrifugal fan)

Accessory part: Inlet ring 31000-2-4013
Not included in scope of delivery. Dimensions: see "Accessories" chapter

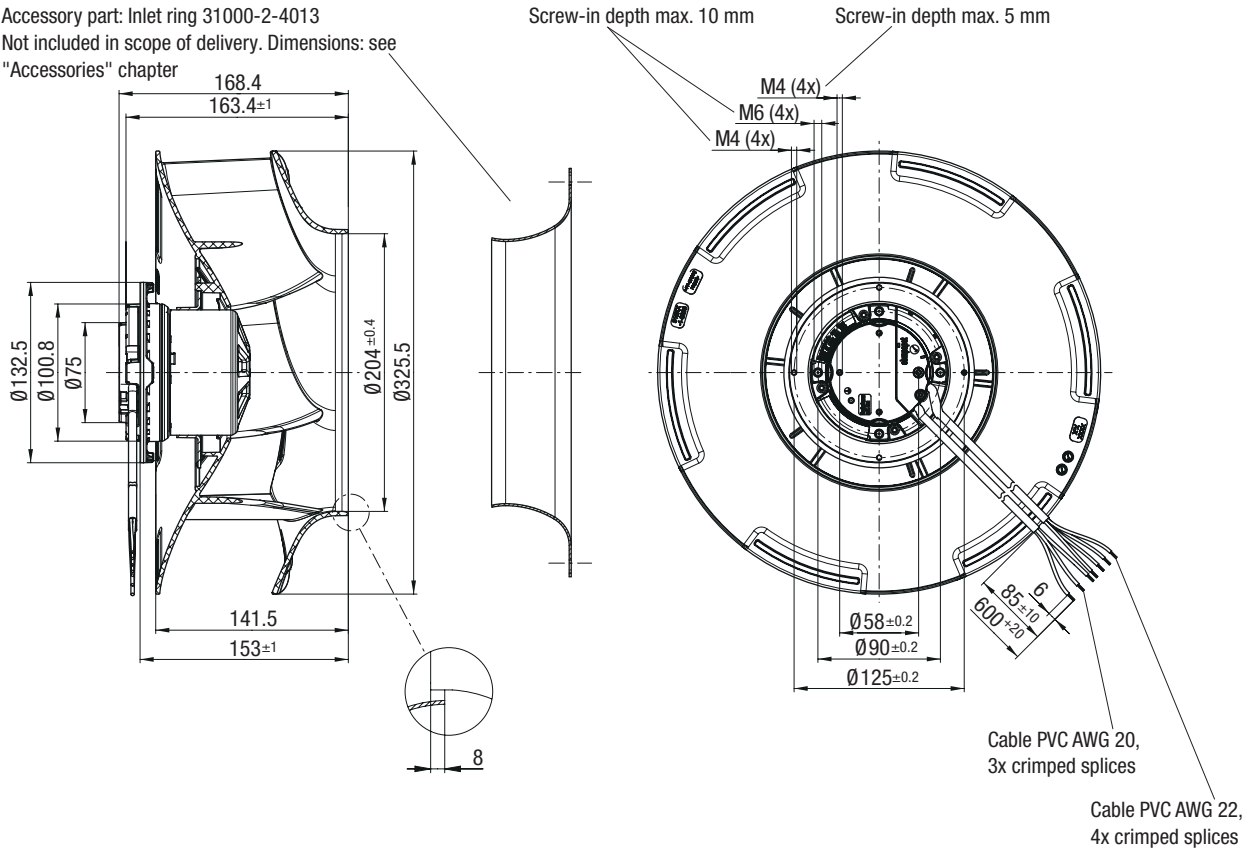

K3G 310-RB01-03 (Centrifugal module with support bracket)

Note installed position! Install support struts as illustrated

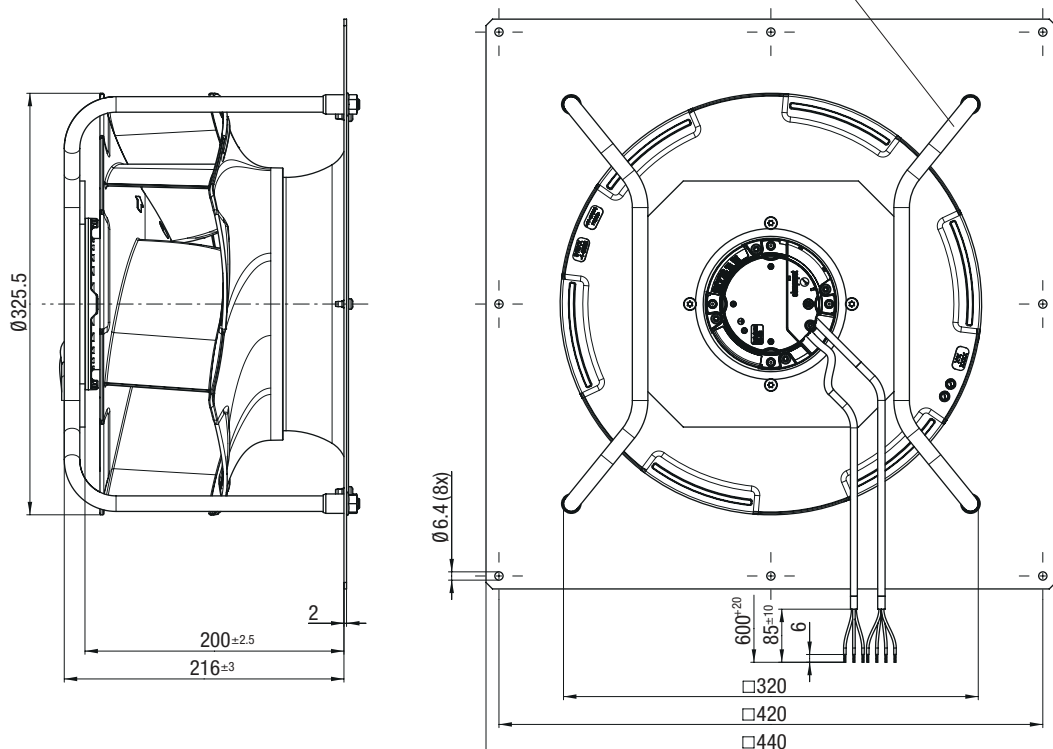

EC centrifugal fans – RadiCal

backward curved, Ø 310



R3G 310-RR05-H1 (Centrifugal fan)

Accessory part: Inlet ring 31000-2-4013
Not included in scope of delivery
Dimensions: see "Accessories" chapter

Screw-in depth max. 16 mm

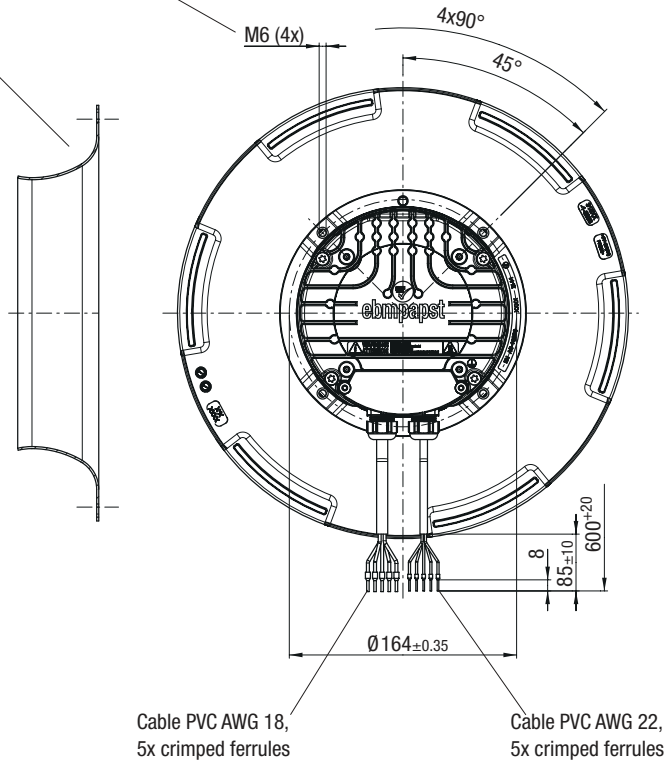
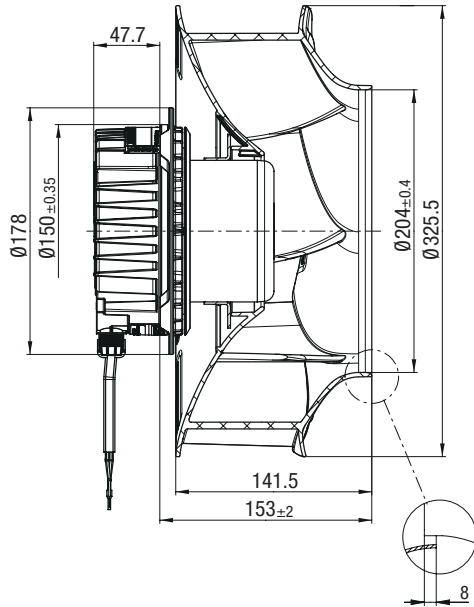

K3G 310-RR05-H2 (Centrifugal module with support bracket)

Note installed position! Install support struts as illustrated

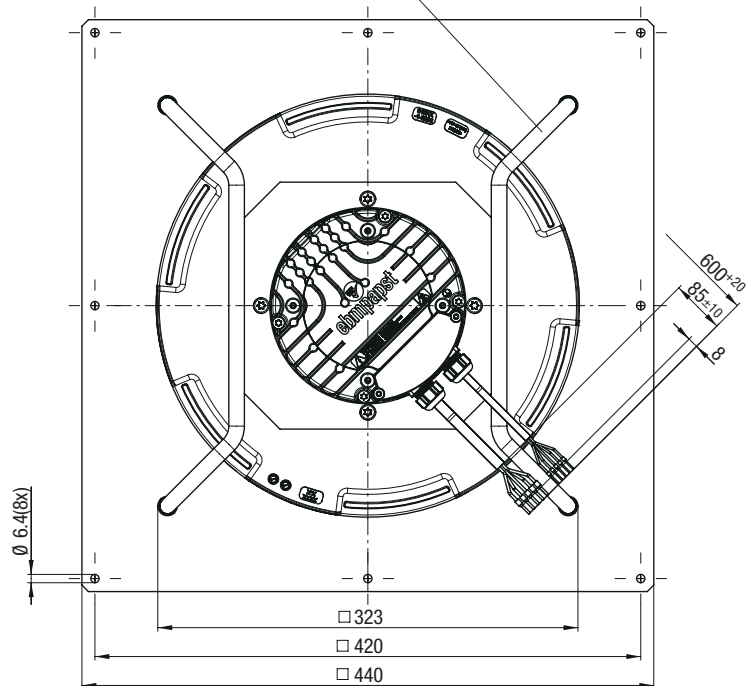
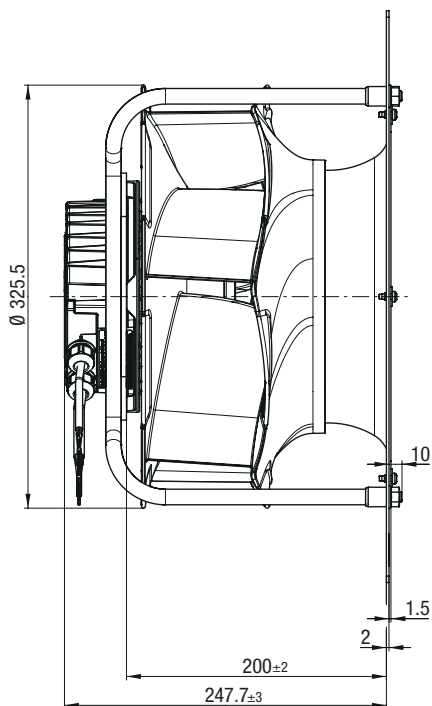

EC centrifugal fans – RadiCal

backward curved, Ø 310



R3G 310-RS01-I1 (Centrifugal fan)

Accessory part: Inlet ring 31000-2-4013
Not included in scope of delivery
Dimensions: see "Accessories" chapter

Screw-in depth max. 10 mm

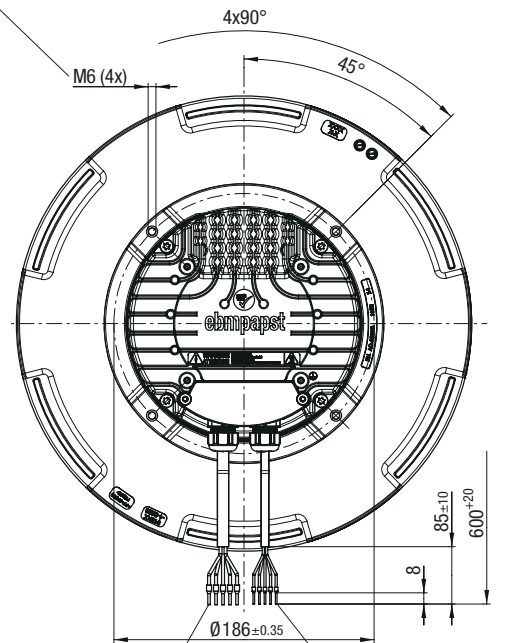
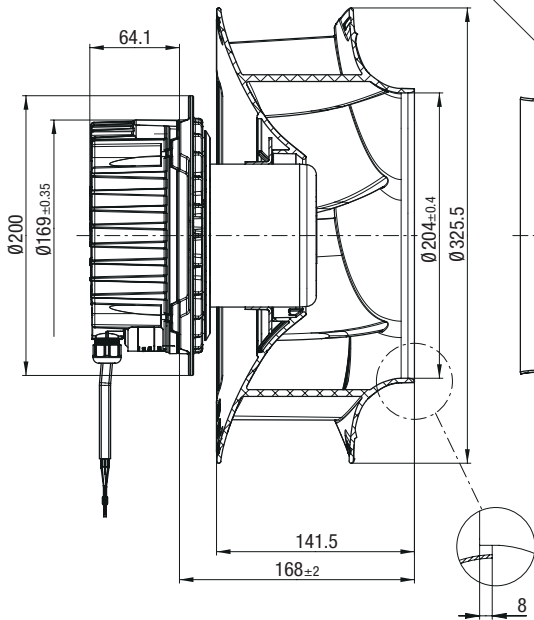

Cable PVC AWG 18,
5x crimped ferrules

Cable PVC AWG 22,
5x crimped ferrules

K3G 310-RS01-I2 (Centrifugal module with support bracket)

Note installed position! Install support struts as illustrated

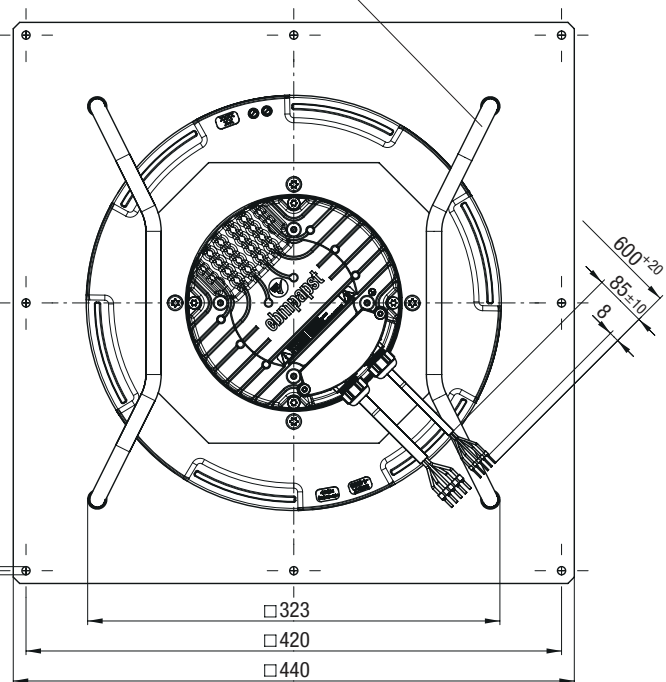
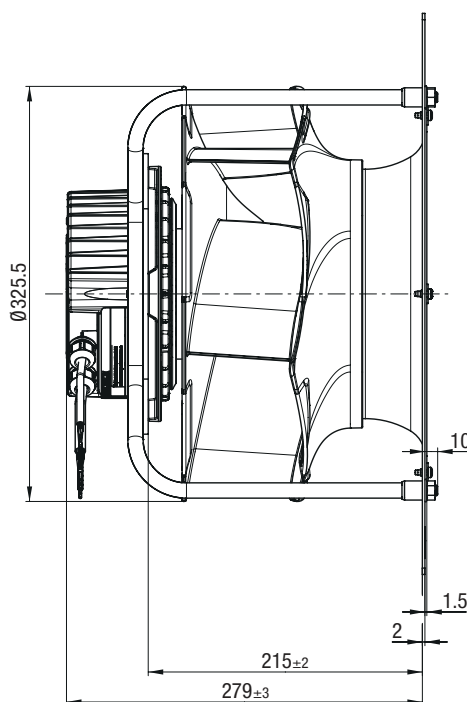

EC centrifugal fans – RadiCal

backward curved, Ø 310



R3G 310-RS05-J1 (Centrifugal fan)

Accessory part: Inlet ring 31000-2-4013
Not included in scope of delivery
Dimensions: see "Accessories" chapter

Screw-in depth max. 16 mm

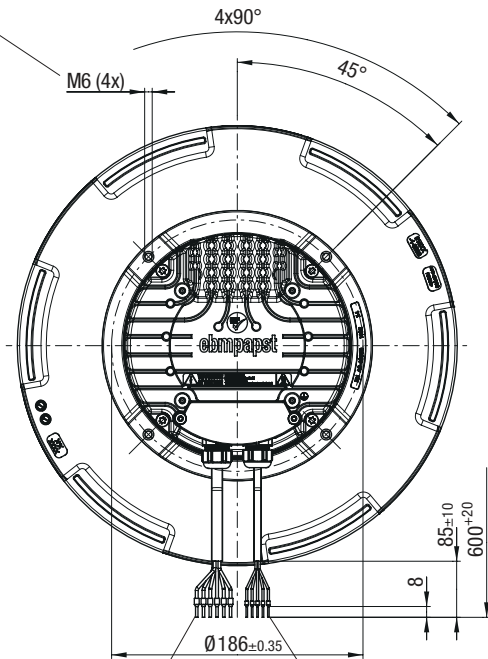
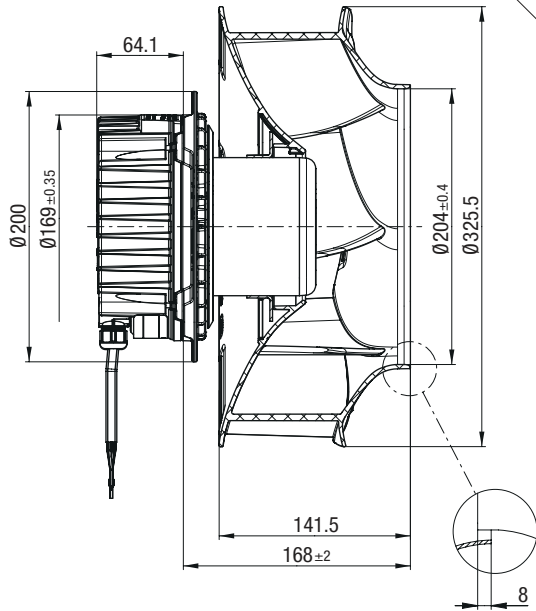

Cable PVC AWG 18,
6x crimped ferrules

Cable PVC AWG 22,
5x crimped ferrules

K3G 310-RS05-J2 (Centrifugal module with support bracket)

Note installed position! Install support struts as illustrated

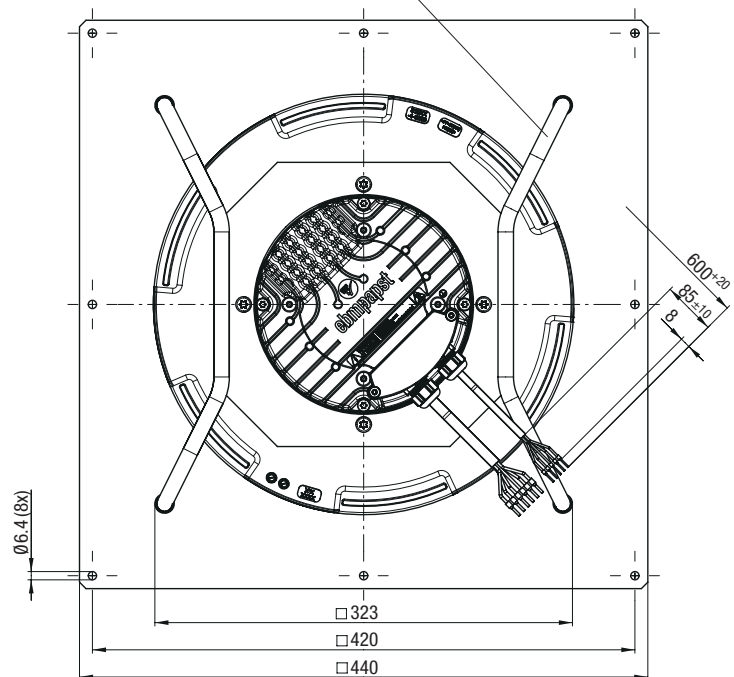
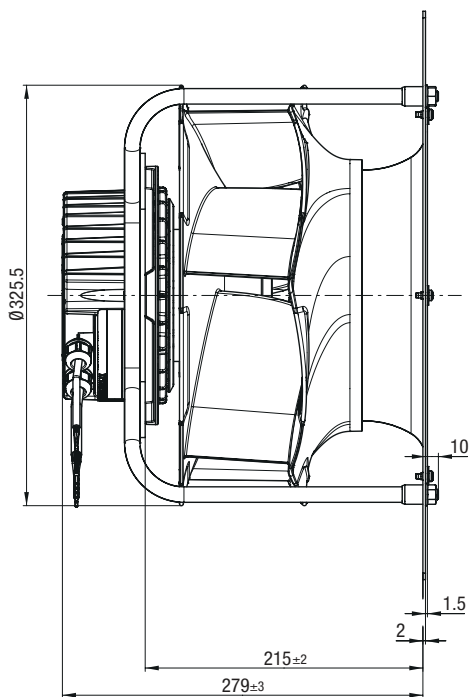

EC centrifugal fans – RadiCal

backward curved, Ø 355



- **Material:** Support bracket: Steel, painted black
Support plate and inlet ring: Sheet steel, galvanized
Impeller: Plastic
Rotor: (A) Surface passivated, (B) (C) (D) (E) Painted black
Electronics housing: Die-cast aluminium
- **Number of blades:** 6
- **Direction of rotation:** Clockwise viewed toward rotor
- **Degree of protection:** (A) IP 54, (B) (C) (D) (E) IP 55
- **Insulation class:** (A) "B", (B) (C) (D) (E) "F"
- **Installation position:** (A) Any,
(B) (C) (D) (E) Shaft horizontal or rotor on bottom, rotor on top on request
- **Condensation drainage holes:** (A) None, open rotor (B) (C) (D) (E) Rotor side
- **Mode:** Continuous operation (S1)
- **Mounting:** Maintenance-free ball bearings

Nominal data

| Type | Motor | Curve | Nominal voltage range | Frequency | Speed ⁽¹⁾ | Max. Input power ⁽¹⁾ | Max. Input current ⁽¹⁾ | Perm. ambient temp. | Techn. features and connection diagram |
|---------|------------|---------------|-----------------------|-----------|----------------------|---------------------------------|-----------------------------------|---------------------|--|
| Type | Motor | VAC | Hz | rpm | W | A | °C | | |
| *3G 355 | M3G 074-DF | (A) 1~200-240 | 50/60 | 1250 | 168 | 1,40 | -25..+60 | P. 146 / RC3) | |
| *3G 355 | M3G 084-DF | (B) 1~200-277 | 50/60 | 1450 | 250 | 1,10 | -25..+60 | P. 147 / RC4) | |
| *3G 355 | M3G 084-FA | (C) 1~200-277 | 50/60 | 1850 | 500 | 2,20 | -25..+60 | P. 147 / RC4) | |
| *3G 355 | M3G 084-GF | (D) 1~200-277 | 50/60 | 2100 | 750 | 3,30 | -25..+55 | P. 147 / RC4) | |
| *3G 355 | M3G 112-EA | (E) 3~380-480 | 50/60 | 2400 | 1100 | 1,70 | -25..+60 | P. 148 / RC5) | |

Subject to change

(1) Nominal data at operating point with maximum load and 230 or 400 VAC.

Curves:

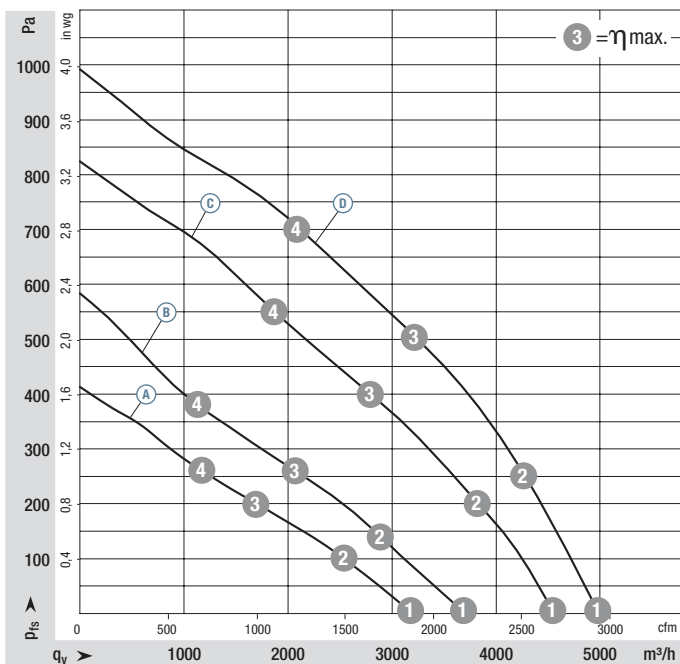

| | n rpm | P _{ed} W | I A | L _{WA} dB(A) |
|-------|-------|-------------------|------|-----------------------|
| (A) 1 | 1425 | 165 | 1,35 | 71 |
| (A) 2 | 1305 | 165 | 1,35 | 65 |
| (A) 3 | 1250 | 168 | 1,40 | 58 |
| (A) 4 | 1280 | 165 | 1,36 | 60 |
| (B) 1 | 1660 | 250 | 1,10 | 77 |
| (B) 2 | 1505 | 250 | 1,10 | 68 |
| (B) 3 | 1450 | 250 | 1,10 | 63 |
| (B) 4 | 1525 | 250 | 1,10 | 68 |
| (C) 1 | 2050 | 456 | 1,99 | 87 |
| (C) 2 | 1935 | 500 | 2,20 | 78 |
| (C) 3 | 1850 | 500 | 2,20 | 69 |
| (C) 4 | 1910 | 500 | 2,20 | 74 |
| (D) 1 | 2245 | 627 | 2,76 | 87 |
| (D) 2 | 2175 | 750 | 3,30 | 82 |
| (D) 3 | 2100 | 750 | 3,30 | 74 |
| (D) 4 | 2155 | 740 | 3,30 | 76 |

Air performance measured according to: ISO 5801, installation category A, with ebm-papst inlet ring without contact protection. Intake-side sound level: L_{WA} according to ISO 13347, L_{pA} measured at 1 m distance from fan axis. The values given are only applicable under the specified measuring conditions and may differ depending on the installation conditions. In the event of deviation from the standard configuration, the parameters must be checked in installed condition. See Page 162 ff. for detailed information.

- **Technical features:** See connection diagram P. 146 ff.
- **EMC:** Interference emission according to EN 61000-6-3
 - Ⓔ According to 61000-6-3 (household environment), except EN 61000-3-2 for professionally used equipment with a total rated power greater than 1 kW
 - Immunity to interference according to EN 61000-6-2; Ⓔ according to EN 61000-6-2 (industrial environment)
 - Circuit feedback according to EN 61000-3-2/3
 - Ⓐ On account of the installation conditions, ferritic damping in the connection line may be required for the application.
- **Touch current:** < 3,5 mA according to IEC 60990 (measuring circuit Fig. 4)
- **Cable exit:** Variable
- **Protection class:** I (with customer connection of protective earth)
- **Conformity with standards:** Ⓐ EN 60335-1, CE; Ⓑ Ⓒ Ⓓ EN 60335-1, EN 61800-5-1, CE; Ⓔ EN 61800-5-1, CE
- **Approvals:** Ⓐ VDE, CURUS on request; Ⓑ Ⓒ Ⓓ Ⓔ VDE, UL, CSA, CCC, EAC
- **Efficiency:** Ecodesign EU regulation EU 327/2011



Weight Centrifugal fan

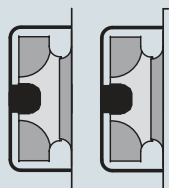

Weight Centrifugal module with support bracket

| Centrifugal fan | kg | Centrifugal module with support bracket | kg |
|------------------|------|---|------|
| R3G 355-RB03 -03 | 3,70 | K3G 355-RB03 -03 | 9,70 |
| R3G 355-RR06 -G1 | 5,00 | K3G 355-RR06 -G2 | 10,8 |
| R3G 355-RS02 -H1 | 5,70 | K3G 355-RS02 -H2 | 11,6 |
| R3G 355-RT01 -I1 | 7,00 | K3G 355-RT01 -I2 | 15,4 |
| R3G 355-RJ75 -01 | 8,40 | K3G 355-RJ75 -01 | 16,4 |

Curves:

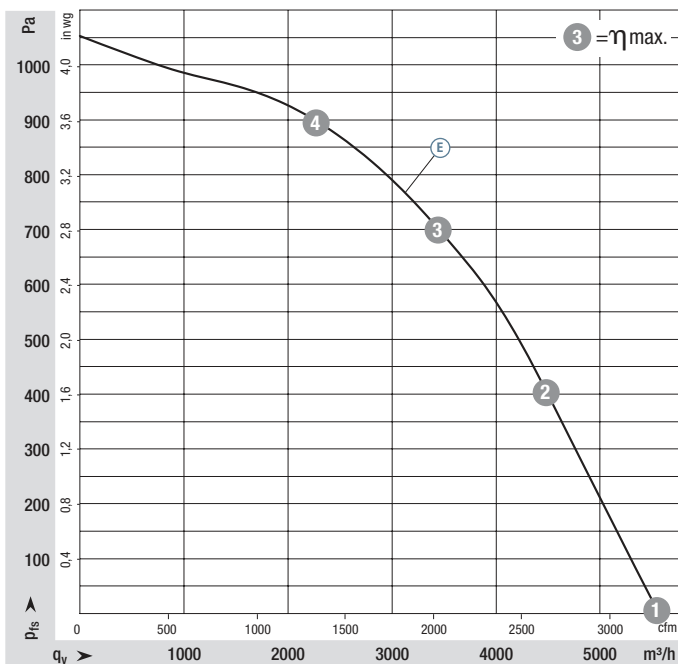

| | n rpm | P _{ed} W | I A | L _{wA} dB(A) |
|-----|-------|-------------------|------|-----------------------|
| Ⓔ 1 | 2400 | 770 | 1,20 | 91 |
| Ⓔ 2 | 2400 | 1026 | 1,58 | 83 |
| Ⓔ 3 | 2400 | 1100 | 1,70 | 76 |
| Ⓔ 4 | 2400 | 961 | 1,49 | 81 |

Air performance measured according to: ISO 5801, installation category A, with ebm-papst inlet ring without contact protection. Intake-side sound level: L_{wA} according to ISO 13347, L_{pA} measured at 1 m distance from fan axis. The values given are only applicable under the specified measuring conditions and may differ depending on the installation conditions. In the event of deviation from the standard configuration, the parameters must be checked in installed condition. See Page 162 ff. for detailed information.

EC centrifugal fans – RadiCal

backward curved, Ø 355



R3G 355-RB03-03 (Centrifugal fan)

Accessory part: Inlet ring 35500-2-4013
Not included in scope of delivery. Dimensions: see "Accessories" chapter

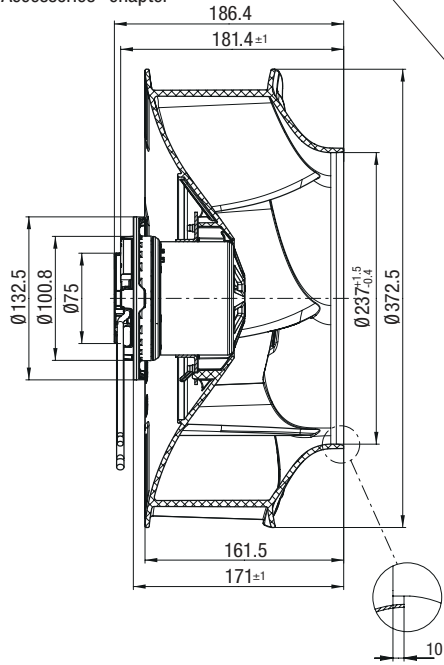

Screw-in depth max. 10 mm Screw-in depth max. 5 mm

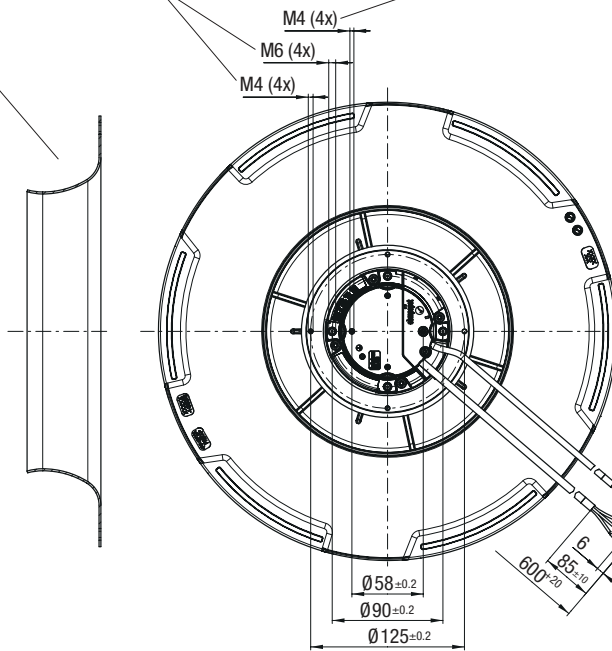

Cable AWG 20,
3x crimped splices

Cable AWG 22,
4x crimped splices

K3G 355-RB03-03 (Centrifugal module with support bracket)

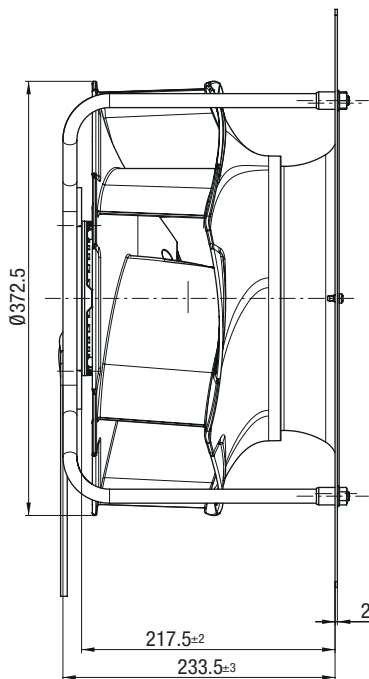

Note installed position! Install support struts as illustrated

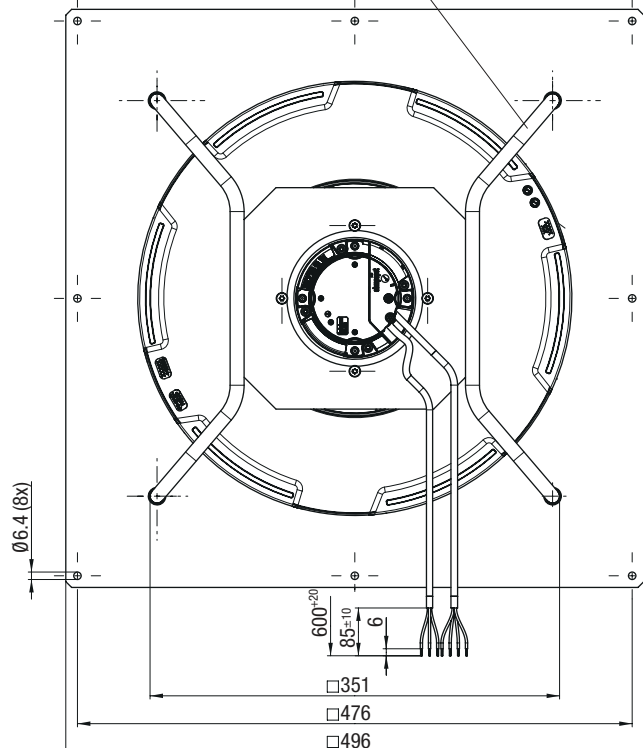

EC centrifugal fans – RadiCal

backward curved, Ø 355



R3G 355-RR06-G1 (Centrifugal fan)

Accessory part: Inlet ring 35500-2-4013
Not included in scope of delivery
Dimensions: see "Accessories" chapter

Screw-in depth max. 16 mm

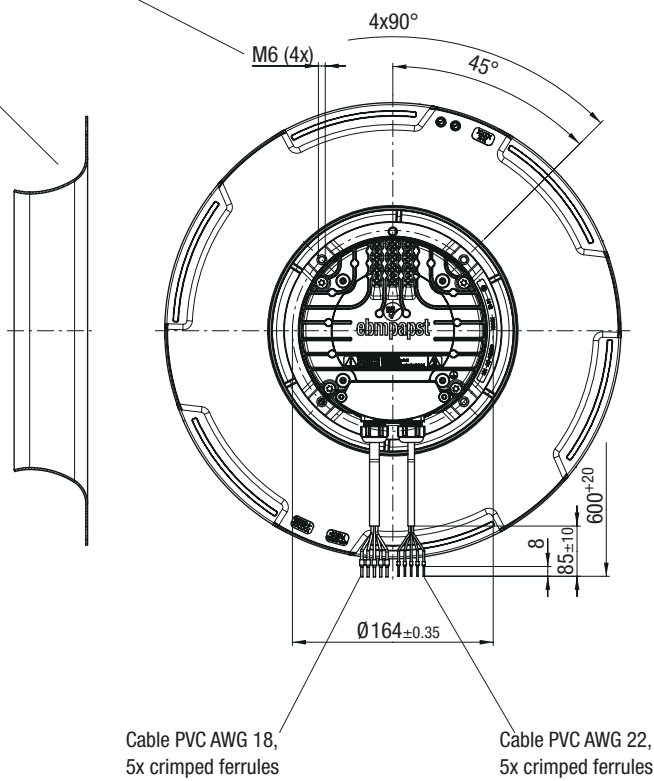
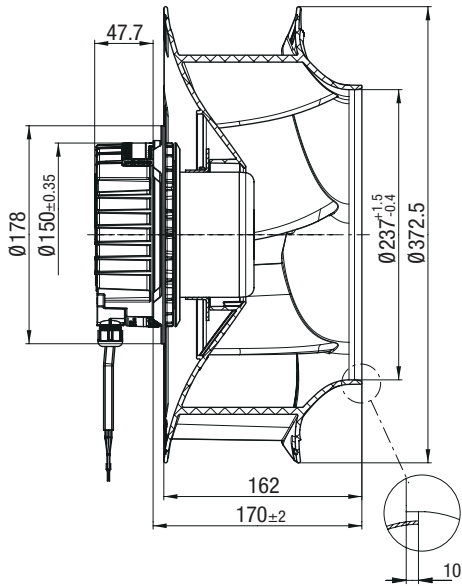

K3G 355-RR06-G2 (Centrifugal module with support bracket)

Note installed position! Install support struts as illustrated

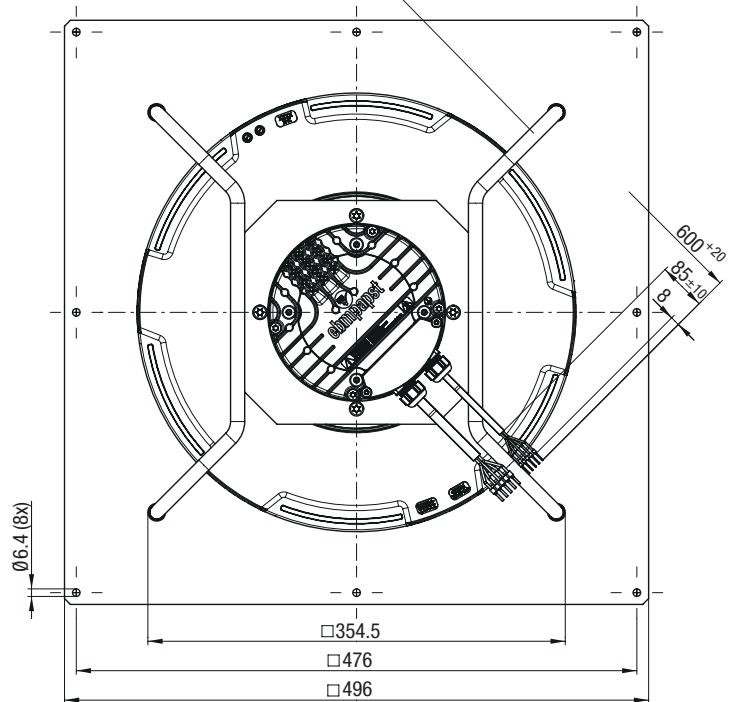
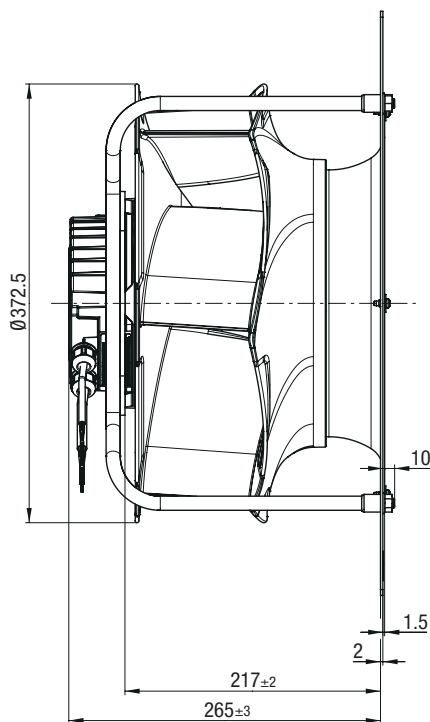

EC centrifugal fans – RadiCal

backward curved, Ø 355

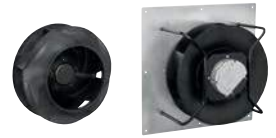

R3G 355-RS02-H1 (Centrifugal fan)

Accessory part: Inlet ring 35500-2-4013
Not included in scope of delivery
Dimensions: see "Accessories" chapter

Screw-in depth max. 16 mm

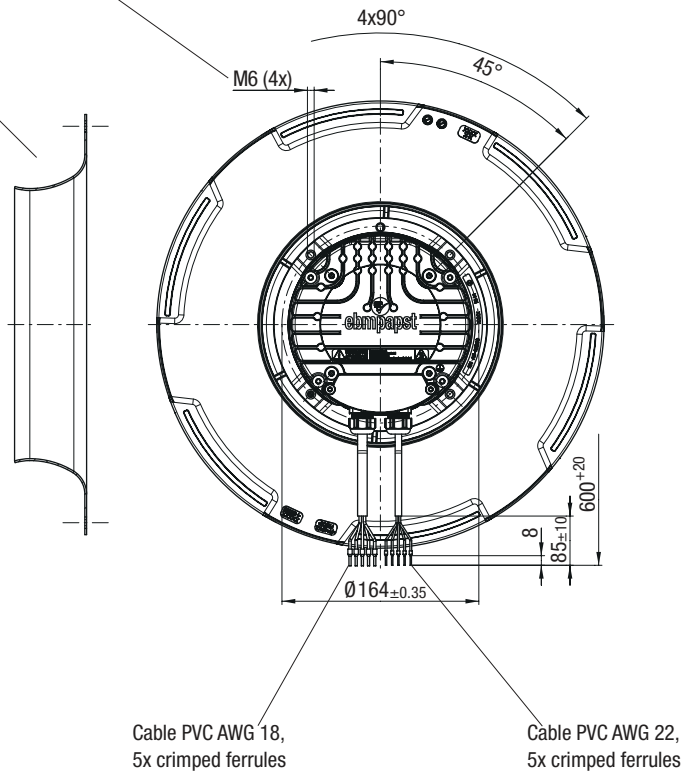
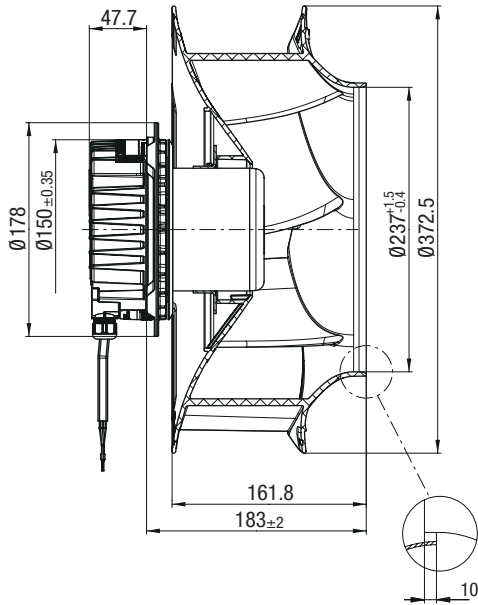

K3G 355-RS02-H2 (Centrifugal module with support bracket)

Note installed position! Install support struts as illustrated

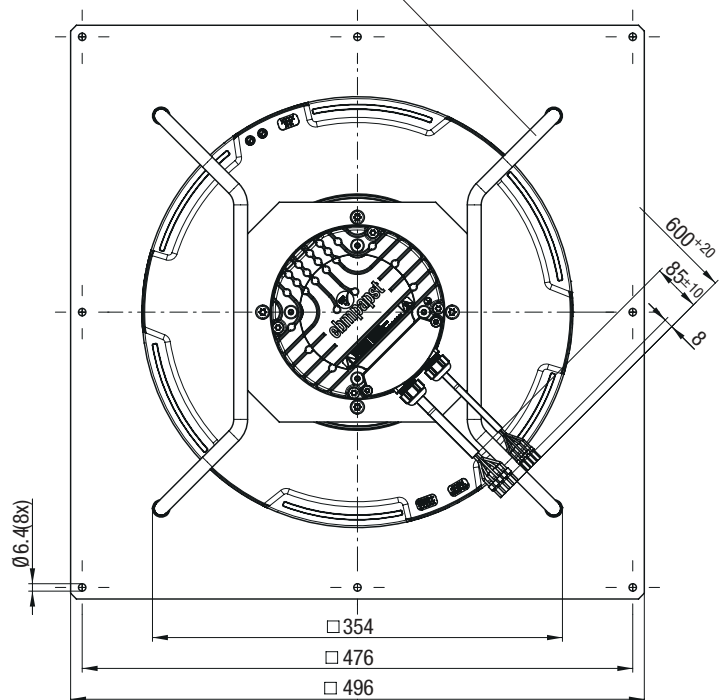
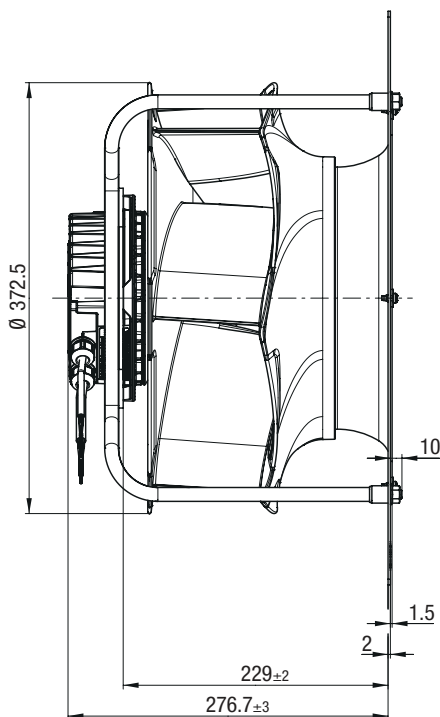

EC centrifugal fans – RadiCal

backward curved, Ø 355

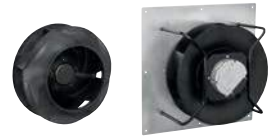

R3G 355-RT01-I1 (Centrifugal fan)

Accessory part: Inlet ring 35500-2-4013
Not included in scope of delivery
Dimensions: see "Accessories" chapter

Screw-in depth max. 16 mm

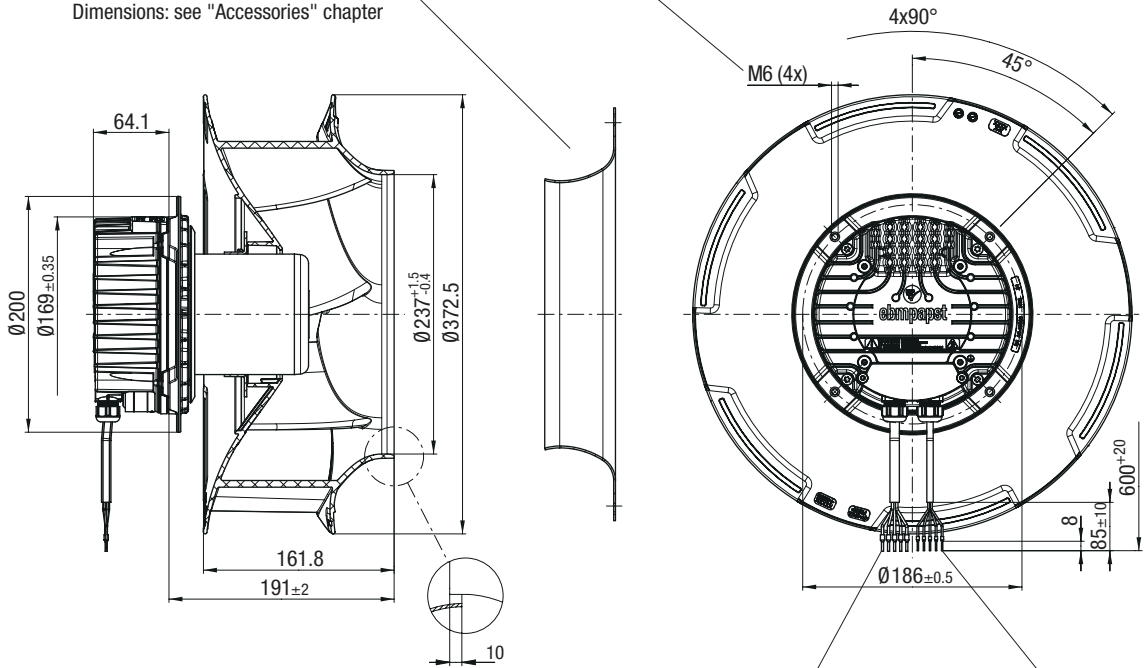

Cable PVC AWG 18,
5x crimped ferrules

Cable PVC AWG 22,
5x crimped ferrules

K3G 355-RT01-I2 (Centrifugal module with support bracket)

Note installed position! Install support struts as illustrated

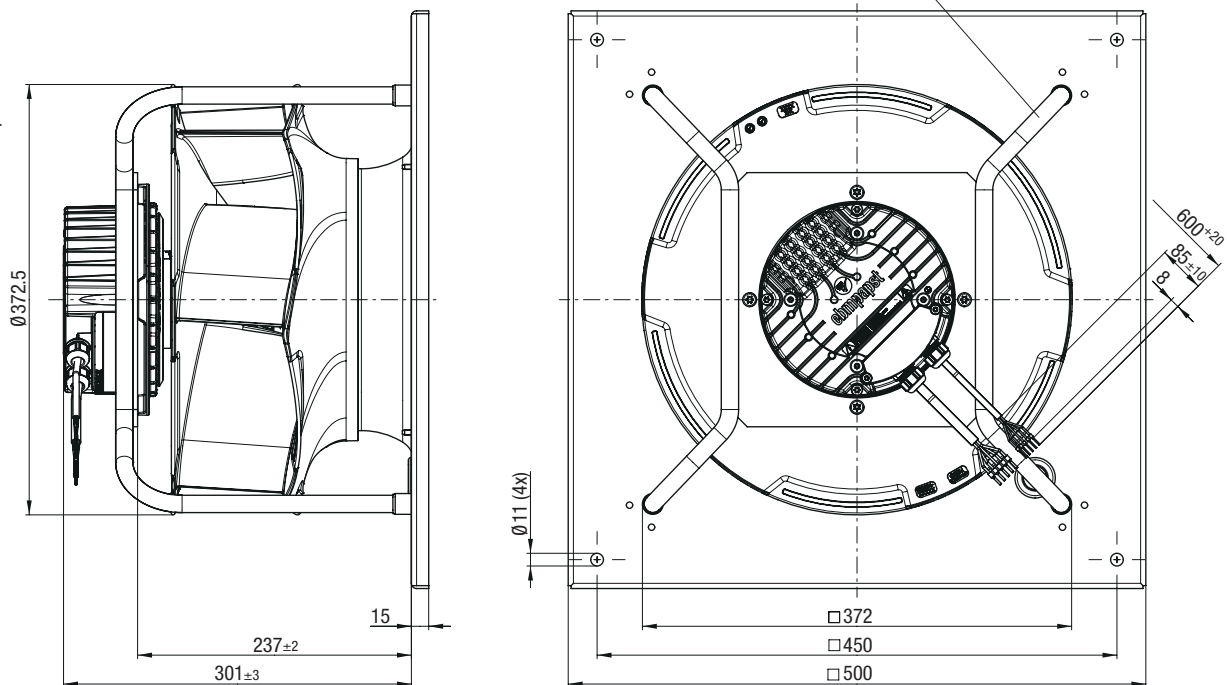

EC centrifugal fans – RadiCal

backward curved, Ø 355

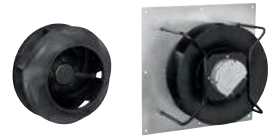

R3G 355-RJ75-01 (Centrifugal fan)

Accessory part: Inlet ring 35500-2-4013
Not included in scope of delivery
Dimensions: see "Accessories" chapter

Screw-in depth max. 16 mm

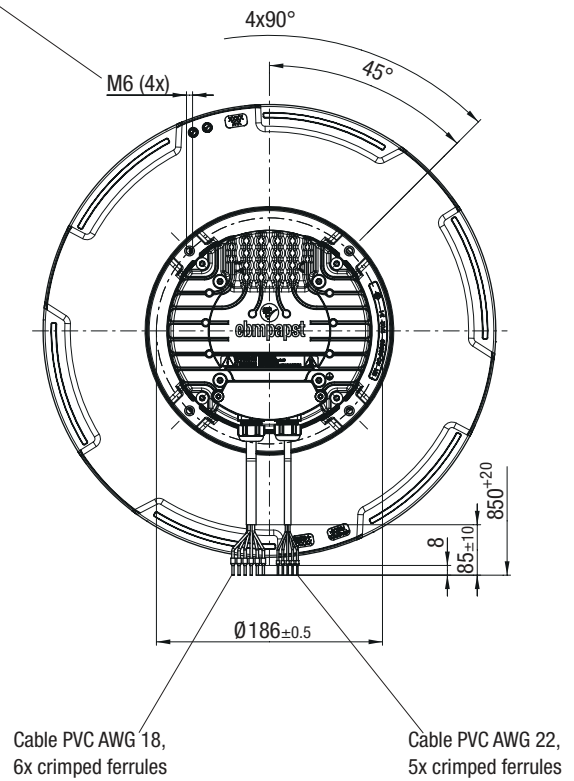
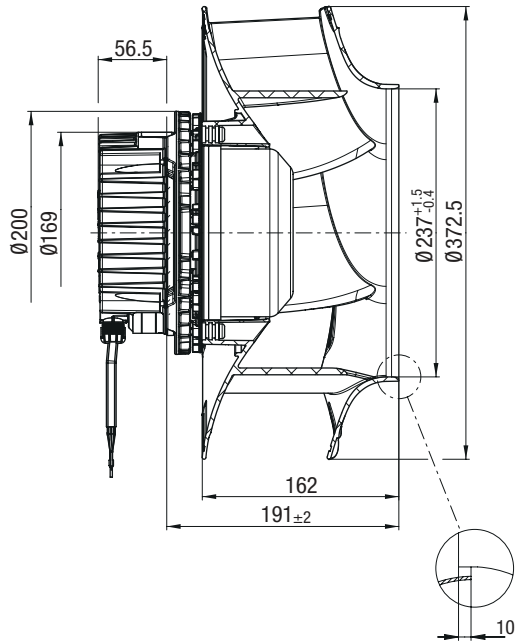

K3G 355-RJ75-01 (Centrifugal module with support bracket)

Note installed position! Install support struts as illustrated

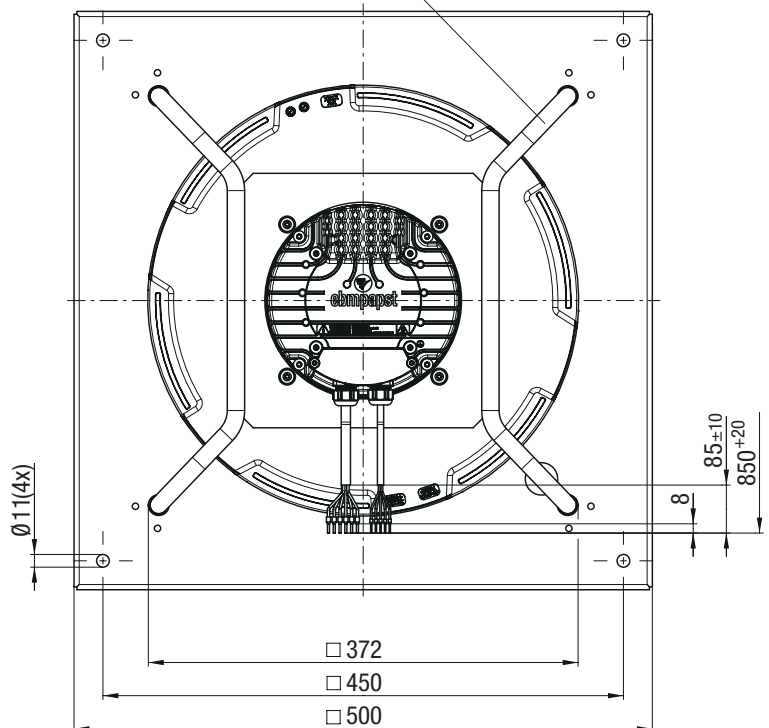
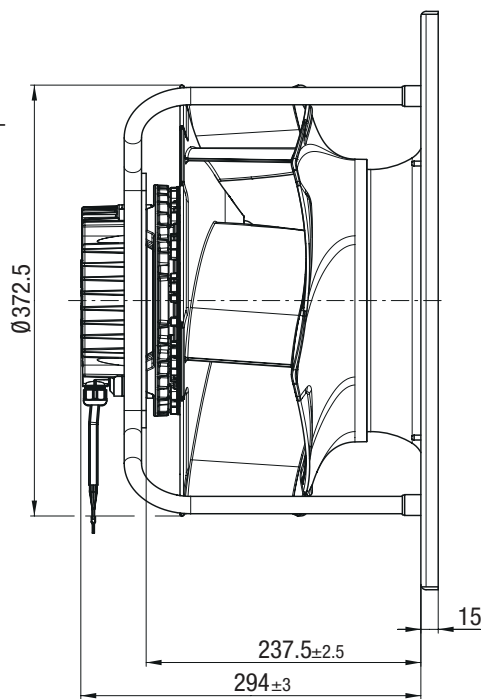

EC centrifugal fans – RadiCal

backward curved, Ø 400



- **Material:** Support bracket: Steel, painted black
Support plate and inlet ring: Sheet steel, galvanized
Impeller: Plastic
Rotor: Painted black
Electronics housing: Die-cast aluminium
- **Number of blades:** 6
- **Direction of rotation:** Clockwise viewed toward rotor
- **Degree of protection:** IP 55
- **Insulation class:** "F"
- **Installation position:** Shaft horizontal or rotor on bottom, rotor on top on request
- **Condensation drainage holes:** Rotor side
- **Mode:** Continuous operation (S1)
- **Mounting:** Maintenance-free ball bearings

Nominal data

| Type | Motor | Curve | Nominal voltage range | Frequency | Speed ⁽¹⁾ | Max. Input power ⁽¹⁾ | Max. Input current ⁽¹⁾ | Perm. ambient temp. | Techn. features and connection diagram |
|---------|------------|-------------|-----------------------|-----------|----------------------|---------------------------------|-----------------------------------|---------------------|--|
| Type | Motor | VAC | Hz | rpm | W | A | °C | | |
| *3G 400 | M3G 084-DF | Ⓐ 1~200-277 | 50/60 | 1170 | 250 | 1,10 | -25..+60 | P. 147 / RC4) | |
| *3G 400 | M3G 084-FA | Ⓑ 1~200-277 | 50/60 | 1500 | 500 | 2,20 | -25..+50 | P. 147 / RC4) | |
| *3G 400 | M3G 084-GF | Ⓒ 1~200-277 | 50/60 | 1700 | 750 | 3,30 | -25..+55 | P. 147 / RC4) | |
| *3G 400 | M3G 112-EA | Ⓓ 3~380-480 | 50/60 | 2060 | 1320 | 2,10 | -25..+50 | P. 148 / RC5) | |

Subject to change

(1) Nominal data at operating point with maximum load and 230 or 400 VAC.

Curves:

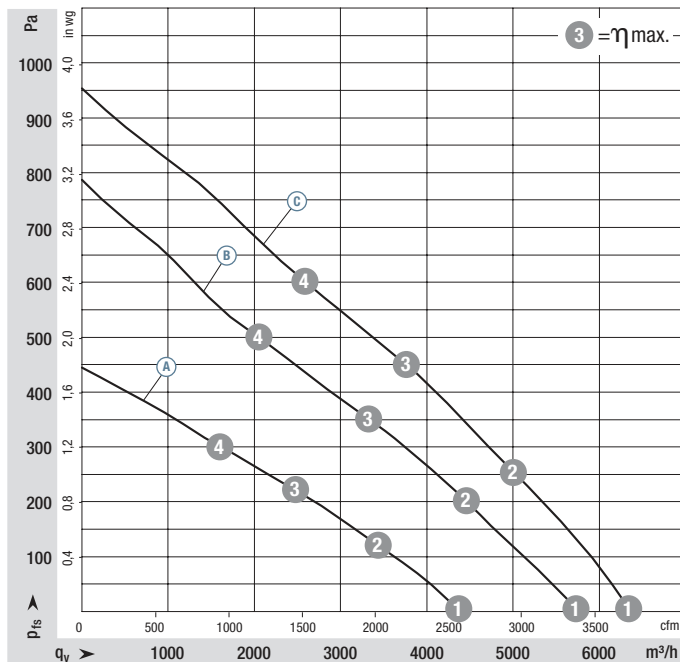

| | n rpm | P _{ed} W | I A | L _{wA} dB(A) |
|-----|-------|-------------------|------|-----------------------|
| Ⓐ ① | 1320 | 238 | 1,05 | 75 |
| Ⓐ ② | 1200 | 250 | 1,10 | 71 |
| Ⓐ ③ | 1170 | 250 | 1,10 | 61 |
| Ⓐ ④ | 1210 | 250 | 1,10 | 67 |
| Ⓑ ① | 1725 | 500 | 2,20 | 80 |
| Ⓑ ② | 1545 | 500 | 2,20 | 73 |
| Ⓑ ③ | 1500 | 500 | 2,20 | 67 |
| Ⓑ ④ | 1570 | 500 | 2,20 | 73 |
| Ⓒ ① | 1925 | 737 | 3,24 | 83 |
| Ⓒ ② | 1755 | 750 | 3,30 | 78 |
| Ⓒ ③ | 1700 | 750 | 3,30 | 72 |
| Ⓒ ④ | 1745 | 750 | 3,30 | 72 |

Air performance measured according to: ISO 5801, installation category A, with ebm-papst inlet ring without contact protection. Intake-side sound level: L_{wA} according to ISO 13347, L_{pA} measured at 1 m distance from fan axis. The values given are only applicable under the specified measuring conditions and may differ depending on the installation conditions. In the event of deviation from the standard configuration, the parameters must be checked in installed condition. See Page 162 ff. for detailed information.

- **Technical features:** See connection diagram P. 147 f.
- **EMC:** Interference emission according to EN 61000-6-3
 - ⓐ According to 61000-6-3 (household environment), except EN 61000-3-2 for professionally used equipment with a total rated power greater than 1 kW
 - Immunity to interference according to EN 61000-6-2; ⓑ according to EN 61000-6-2 (industrial environment)
 - Circuit feedback according to EN 61000-3-2/3
- **Touch current:** < 3,5 mA according to IEC 60990 (measuring circuit Fig. 4)
- **Cable exit:** Variable
- **Protection class:** I (with customer connection of protective earth)
- **Conformity with standards:** ⓐ ⓑ ⓒ EN 60335-1, EN 61800-5-1, CE; ⓓ EN 61800-5-1, CE
- **Approvals:** VDE, UL, CSA, CCC, EAC
- **Efficiency:** Ecodesign EU regulation EU 327/2011



Weight Centrifugal fan

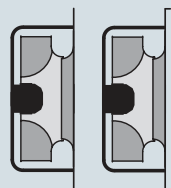

Weight Centrifugal module with support bracket

| Centrifugal fan | kg | Centrifugal module with support bracket | kg |
|------------------|------|---|------|
| R3G 400-RR07 -G1 | 5,60 | K3G 400-RR07 -G2 | 12,5 |
| R3G 400-RS03 -H1 | 6,40 | K3G 400-RS03 -H2 | 13,3 |
| R3G 400-RT02 -I1 | 7,50 | K3G 400-RT02 -I2 | 15,5 |
| R3G 400-RJ75 -01 | 9,10 | K3G 400-RJ75 -01 | 16,5 |

Curves:

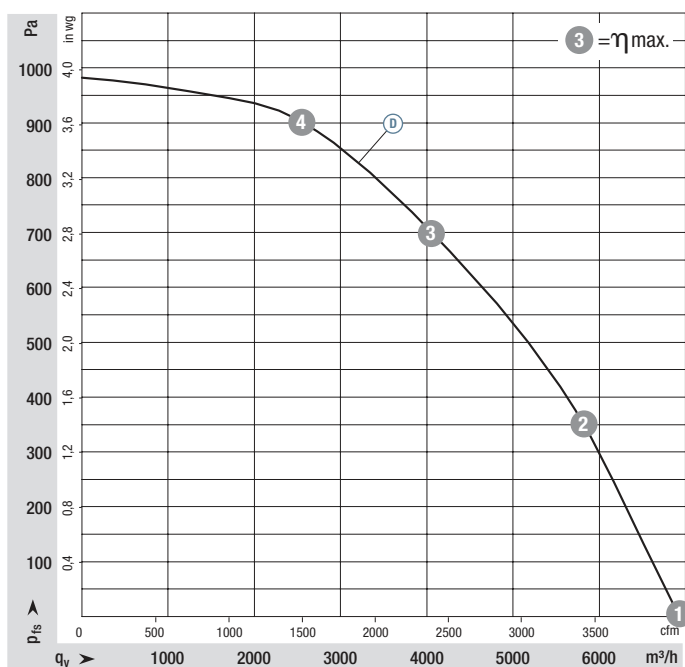

| | n rpm | P _{ed} W | I A | L _{wA} dB(A) |
|-----|-------|-------------------|------|-----------------------|
| ⓓ ① | 2120 | 965 | 1,56 | 89 |
| ⓓ ② | 2110 | 1245 | 2,00 | 82 |
| ⓓ ③ | 2060 | 1320 | 2,10 | 75 |
| ⓓ ④ | 2100 | 1285 | 2,06 | 78 |

Air performance measured according to: ISO 5801, installation category A, with ebm-papst inlet ring without contact protection. Intake-side sound level: L_{wA} according to ISO 13347, L_{pA} measured at 1 m distance from fan axis. The values given are only applicable under the specified measuring conditions and may differ depending on the installation conditions. In the event of deviation from the standard configuration, the parameters must be checked in installed condition. See Page 162 ff. for detailed information.

EC centrifugal fans – RadiCal

backward curved, Ø 400

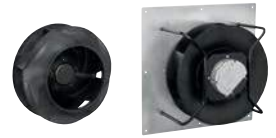

R3G 400-RR07-G1 (Centrifugal fan)

Accessory part: Inlet ring 54476-2-4013
Not included in scope of delivery
Dimensions: see "Accessories" chapter

Screw-in depth max. 16 mm

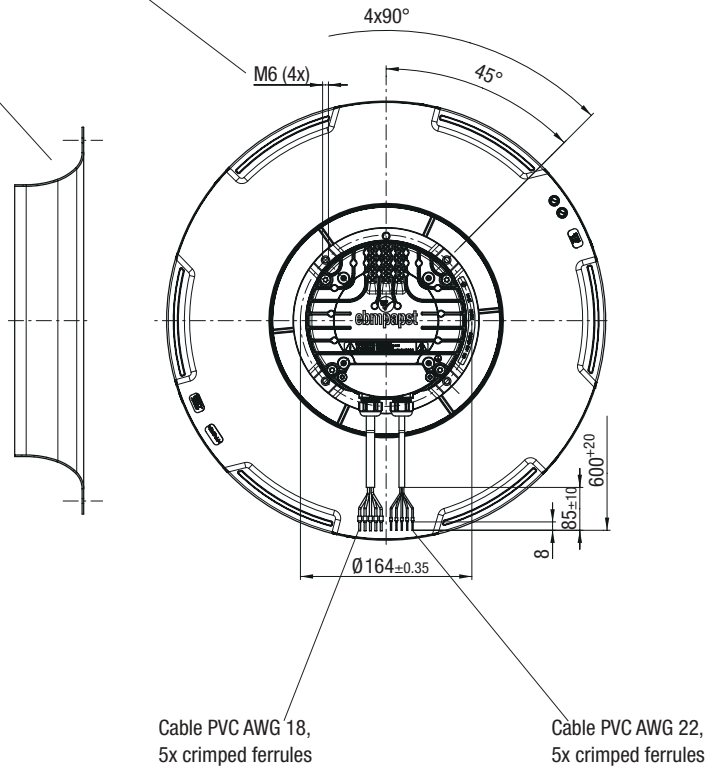
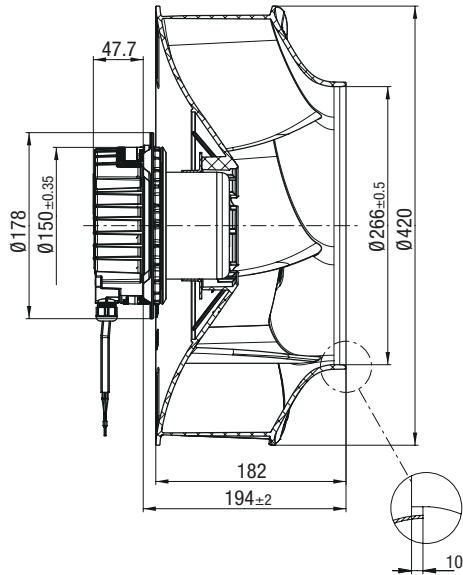

K3G 400-RR07-G2 (Centrifugal module with support bracket)

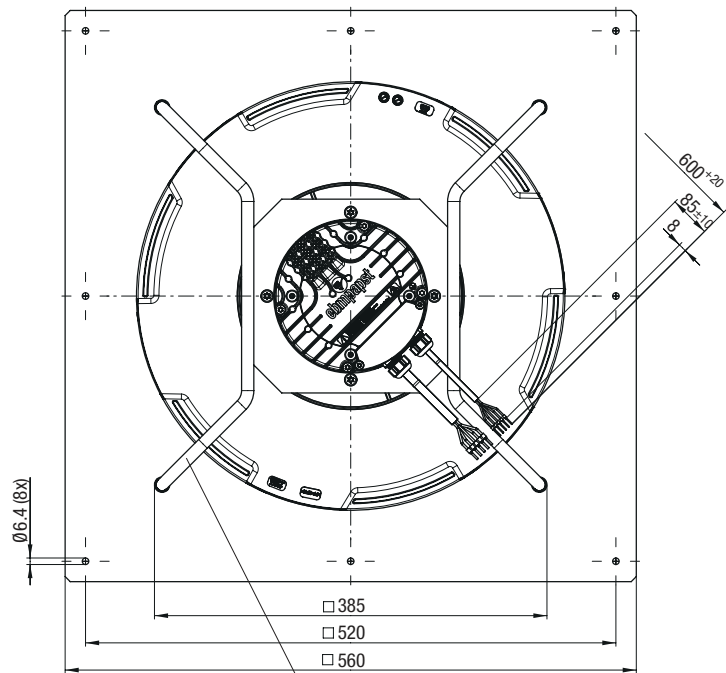
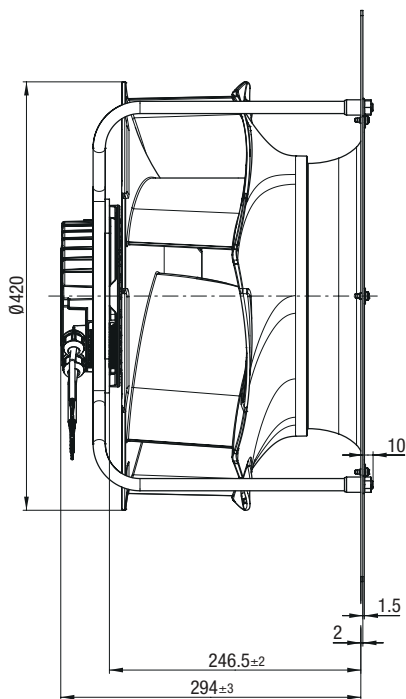

Note installed position! Install support struts as illustrated

EC centrifugal fans – RadiCal

backward curved, Ø 400

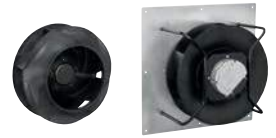

R3G 400-RS03-H1 (Centrifugal fan)

Accessory part: Inlet ring 54476-2-4013
Not included in scope of delivery
Dimensions: see "Accessories" chapter

Screw-in depth max. 16 mm

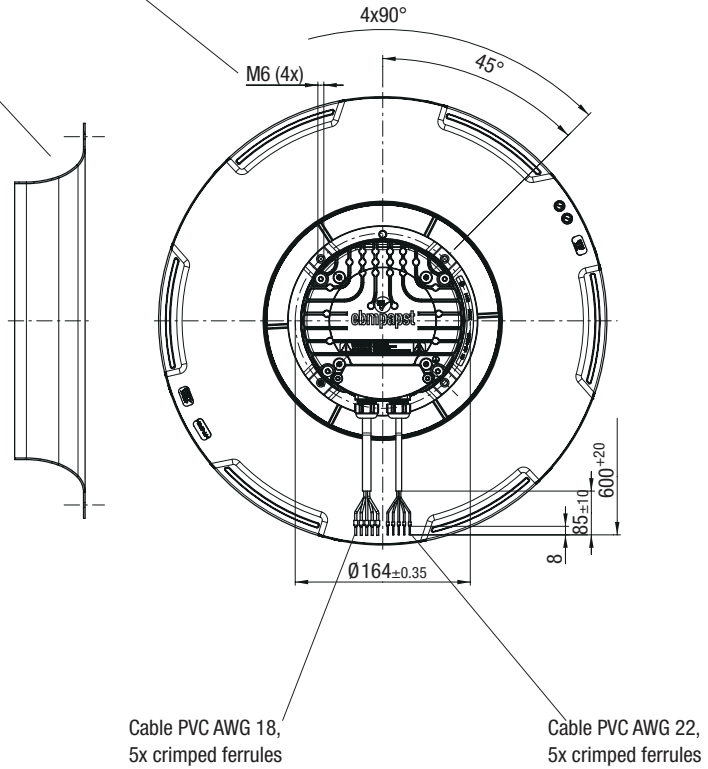
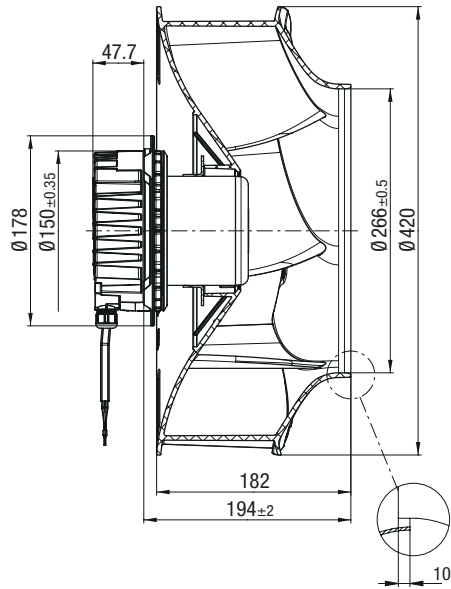

K3G 400-RS03-H2 (Centrifugal module with support bracket)

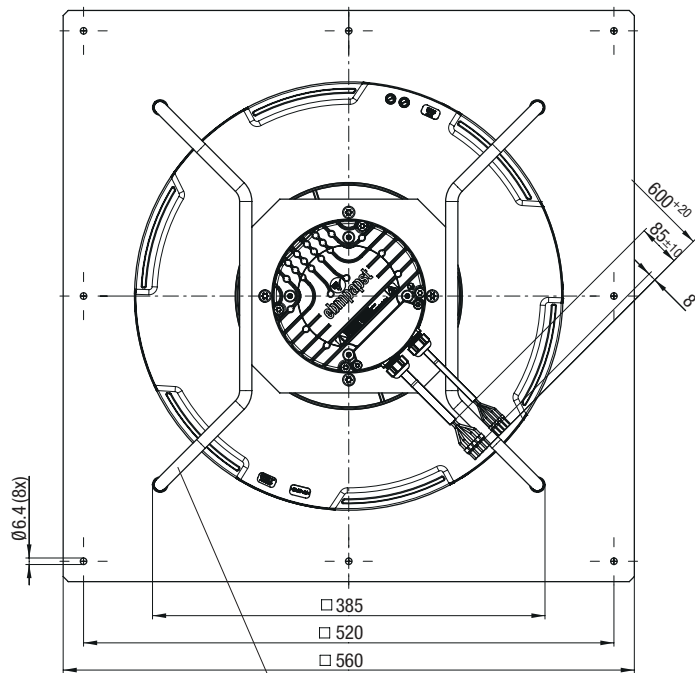
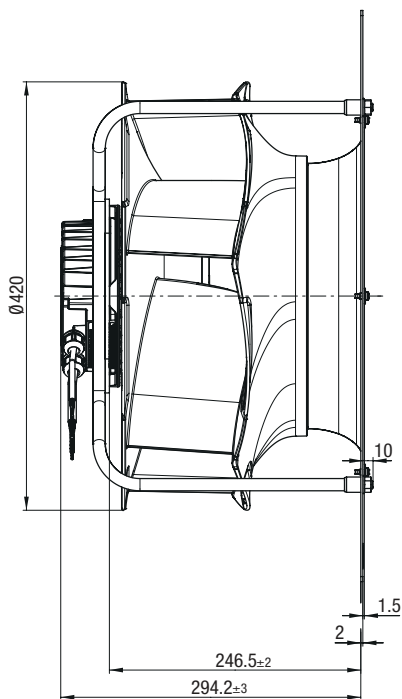

Note installed position! Install support struts as illustrated

EC centrifugal fans – RadiCal

backward curved, Ø 400

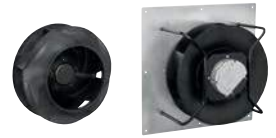

R3G 400-RT02-I1 (Centrifugal fan)

Accessory part: Inlet ring 54476-2-4013
Not included in scope of delivery
Dimensions: see "Accessories" chapter

Screw-in depth max. 16 mm

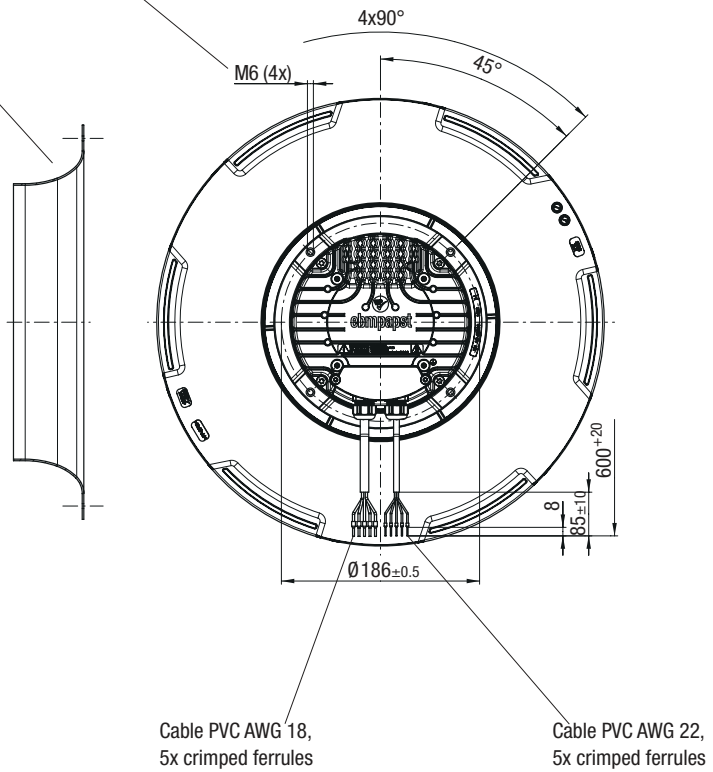
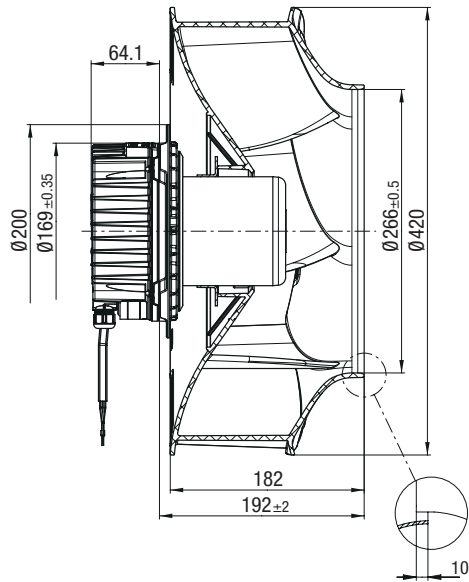

K3G 400-RT02-I2 (Centrifugal module with support bracket)

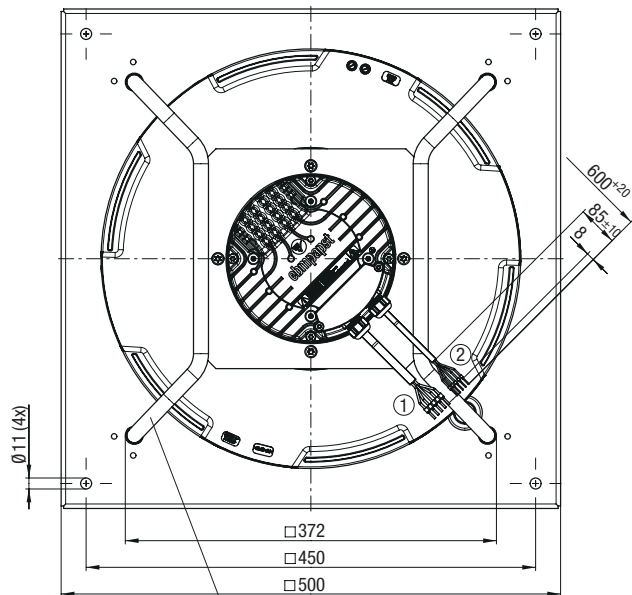
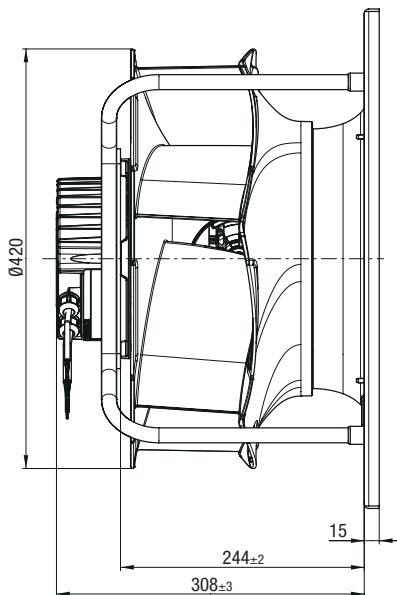

Note installed position! Install support struts as illustrated

EC centrifugal fans – RadiCal

backward curved, Ø 400



R3G 400-RJ75-01 (Centrifugal fan)

Accessory part: Inlet ring 54476-2-4013
Not included in scope of delivery
Dimensions: see "Accessories" chapter

Screw-in depth max. 16 mm

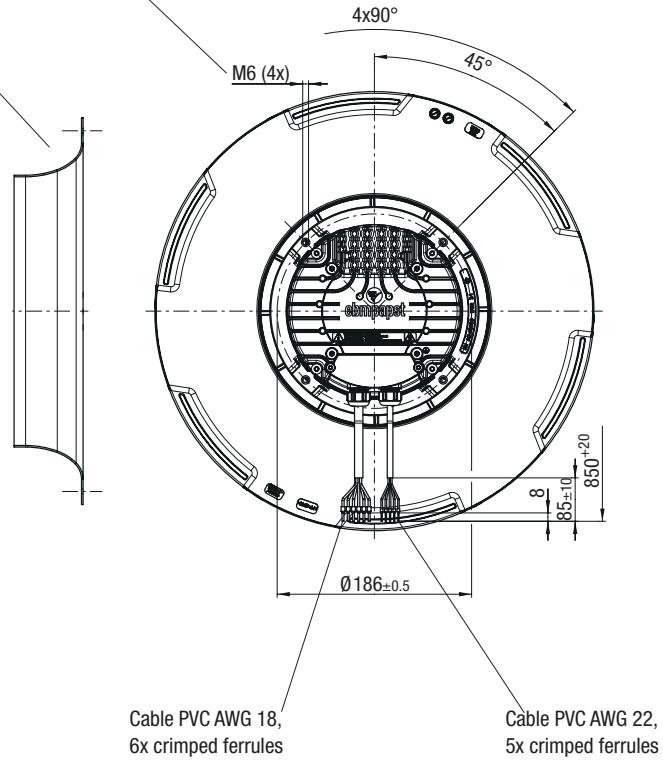
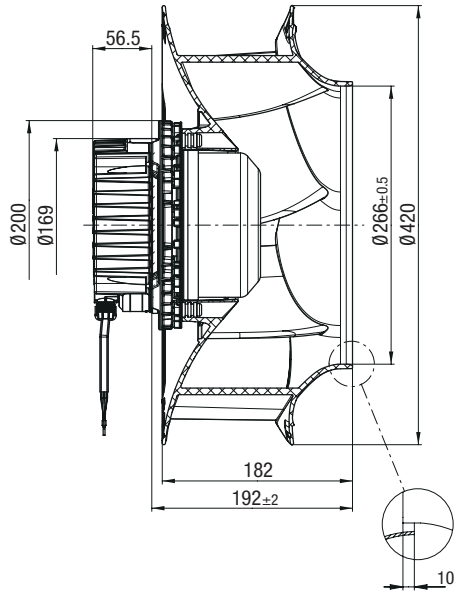

K3G 400-RJ75-01 (Centrifugal module with support bracket)

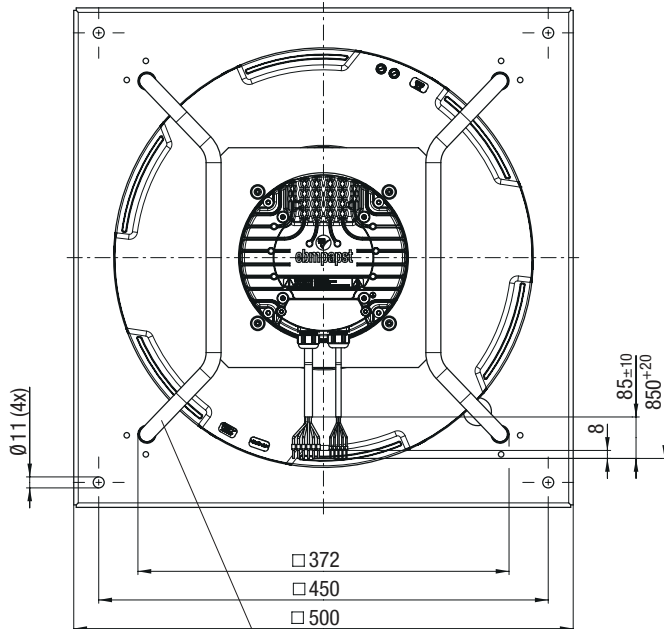
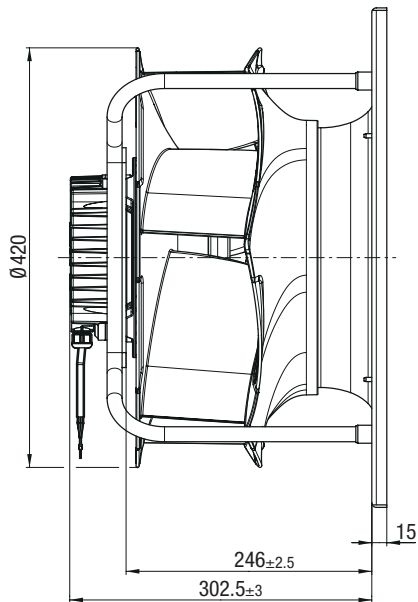

Note installed position! Install support struts as illustrated

EC centrifugal fans – RadiCal

backward curved, Ø 450



- **Material:** Support bracket: Steel, painted black
Support plate: Sheet steel, galvanized
Inlet ring: Plastic
Impeller: Plastic / Rotor: Painted black
Electronics housing: Die-cast aluminium
- **Number of blades:** 6
- **Direction of rotation:** Clockwise viewed toward rotor
- **Degree of protection:** IP 55
- **Insulation class:** "F"
- **Installation position:** Shaft horizontal or rotor on bottom, rotor on top on request
- **Condensation drainage holes:** Rotor side
- **Mode:** Continuous operation (S1)
- **Mounting:** Maintenance-free ball bearings

Nominal data

| Type | Motor | Curve | Nominal voltage range | Frequency | Speed ⁽¹⁾ | Max. Input power ⁽¹⁾ | Max. Input current ⁽¹⁾ | Perm. ambient temp. | Techn. features and connection diagram |
|---------|------------|-------------|-----------------------|-----------|----------------------|---------------------------------|-----------------------------------|---------------------|--|
| Type | Motor | VAC | Hz | rpm | W | A | °C | | |
| *3G 450 | M3G 084-FA | Ⓐ 1~200-277 | 50/60 | 1000 | 250 | 1,10 | -25..+60 | P. 147 / RC4) | |
| *3G 450 | M3G 084-GF | Ⓑ 1~200-277 | 50/60 | 1260 | 500 | 2,20 | -25..+50 | P. 147 / RC4) | |
| *3G 450 | M3G 112-EA | Ⓒ 1~200-277 | 50/60 | 1440 | 750 | 3,30 | -25..+60 | P. 147 / RC4) | |
| *3G 450 | M3G 112-GA | Ⓓ 3~380-480 | 50/60 | 1550 | 950 | 1,50 | -25..+60 | P. 148 / RC5) | |

Subject to change

(1) Nominal data at operating point with maximum load and 230 or 400 VAC.

Curves:

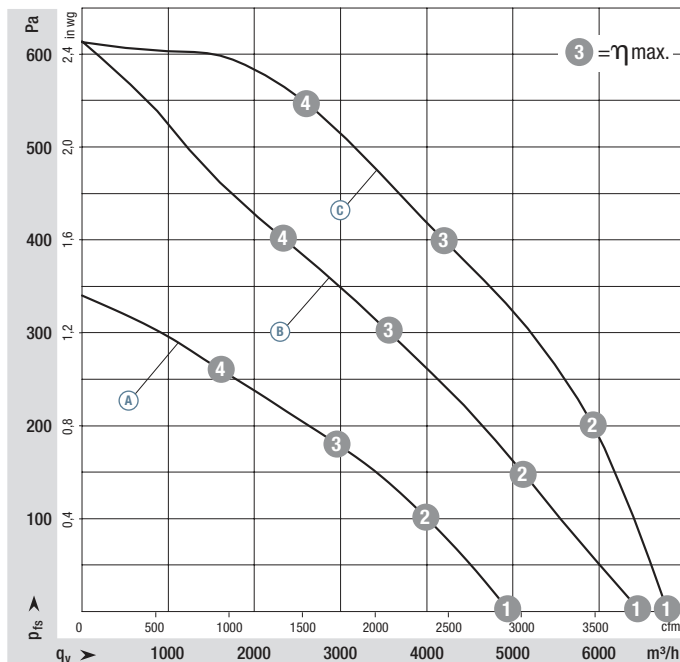

| | n rpm | P _{ed} W | I A | L _{wA} dB(A) |
|-----|-------|-------------------|------|-----------------------|
| Ⓐ ① | 1130 | 228 | 1,03 | 76 |
| Ⓐ ② | 1050 | 250 | 1,10 | 68 |
| Ⓐ ③ | 1000 | 250 | 1,10 | 62 |
| Ⓐ ④ | 1030 | 250 | 1,10 | 70 |
| Ⓑ ① | 1470 | 500 | 2,20 | 93 |
| Ⓑ ② | 1345 | 500 | 2,20 | 75 |
| Ⓑ ③ | 1260 | 500 | 2,20 | 69 |
| Ⓑ ④ | 1295 | 500 | 2,20 | 71 |
| Ⓒ ① | 1550 | 574 | 2,56 | 79 |
| Ⓒ ② | 1520 | 743 | 3,29 | 77 |
| Ⓒ ③ | 1440 | 750 | 3,30 | 72 |
| Ⓒ ④ | 1495 | 750 | 3,30 | 76 |

Air performance measured according to: ISO 5801, installation category A, with ebm-papst inlet ring without contact protection. Intake-side sound level: L_{wA} according to ISO 13347, L_{pA} measured at 1 m distance from fan axis. The values given are only applicable under the specified measuring conditions and may differ depending on the installation conditions. In the event of deviation from the standard configuration, the parameters must be checked in installed condition. See Page 162 ff. for detailed information.

- **Technical features:** See connection diagram P. 147 f.
- **EMC:** (B) (C) (D) Interference emission according to EN 61000-6-3
(B) (C) (D) Immunity to interference according to EN 61000-6-2
(B) (C) (D) Circuit feedback according to EN 61000-3-2/3
- **Touch current:** < 3,5 mA according to IEC 60990 (measuring circuit Fig. 4)
- **Cable exit:** Variable
- **Protection class:** I (with customer connection of protective earth)
- **Conformity with standards:** (A) (B) (C) EN 60335-1, EN 61800-5-1, CE; (D) EN 61800-5-1, CE
- **Approvals:** VDE, UL, CSA, CCC, EAC
- **Efficiency:** Ecodesign EU regulation EU 327/2011

Weight
Centrifugal fanWeight Centrifugal
module with
support bracket

| Centrifugal fan | kg | Centrifugal module with support bracket | kg |
|------------------|------|---|------|
| R3G 450-RS04 -G1 | 6,70 | K3G 450-RS04 -G2 | 16,7 |
| R3G 450-RT03 -H1 | 7,50 | K3G 450-RT03 -H2 | 17,3 |
| R3G 450-RJ74 -21 | 9,30 | K3G 450-RJ74 -21 | 19,3 |
| R3G 450-RK56 -01 | 10,6 | K3G 450-RK56 -01 | 21,0 |

Curves:

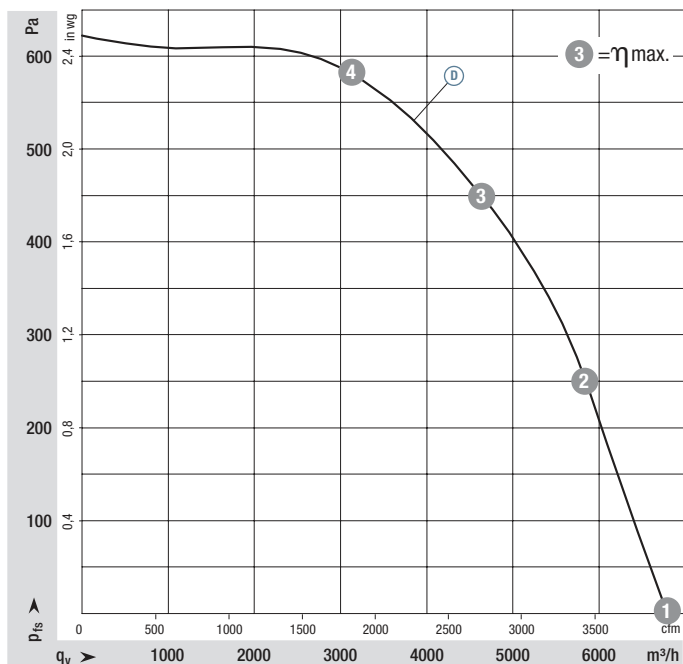

| | n rpm | P _{ed} W | I A | L _{wA} dB(A) |
|-------|----------|----------------------|--------|--------------------------|
| (D) 1 | 1550 | 597 | 0,99 | 79 |
| (D) 2 | 1550 | 836 | 1,35 | 78 |
| (D) 3 | 1550 | 950 | 1,50 | 74 |
| (D) 4 | 1550 | 883 | 1,42 | 75 |

Air performance measured according to: ISO 5801, installation category A, with ebm-papst inlet ring without contact protection. Intake-side sound level: L_{wA} according to ISO 13347, L_{pA} measured at 1 m distance from fan axis. The values given are only applicable under the specified measuring conditions and may differ depending on the installation conditions. In the event of deviation from the standard configuration, the parameters must be checked in installed condition. See Page 162 ff. for detailed information.

EC centrifugal fans – RadiCal

backward curved, Ø 450



R3G 450-RS04-G1 (Centrifugal fan)

Accessory part: Inlet ring 45901-2-2943
(Material: Plastic)
Not included in scope of delivery
Dimensions: see "Accessories" chapter

Screw-in depth max. 16 mm

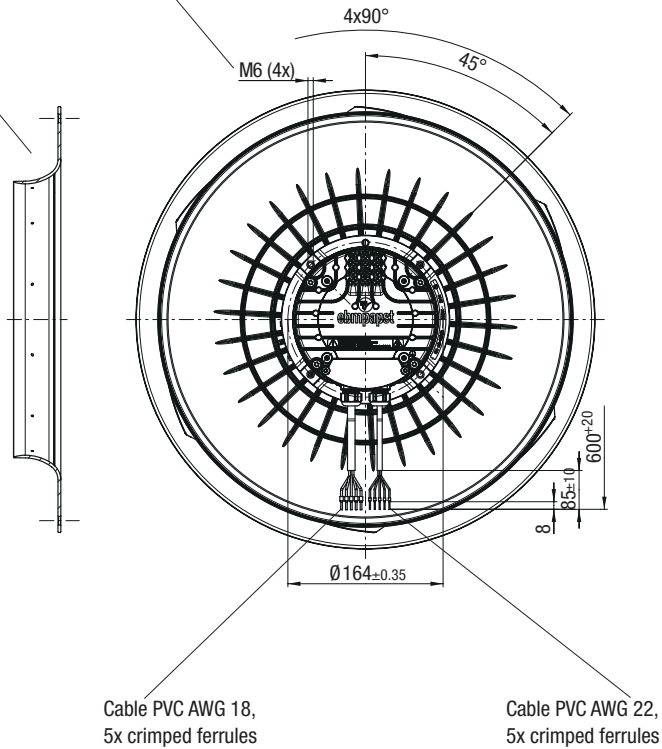
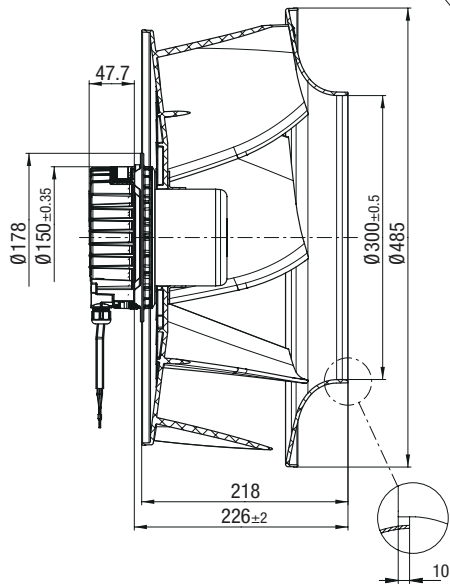

K3G 450-RS04-G2 (Centrifugal module with support bracket)

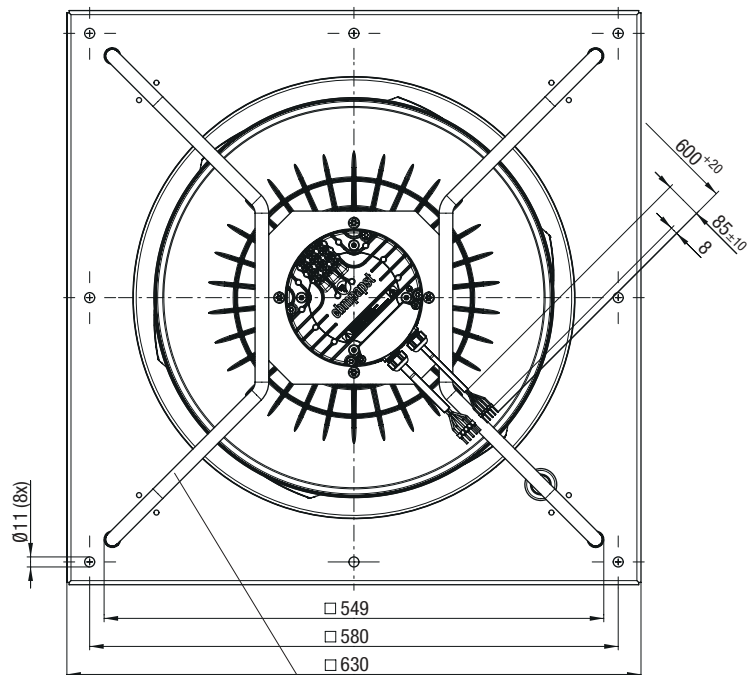
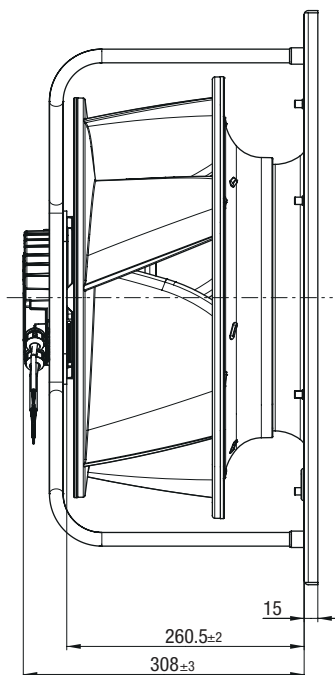

Note installed position! Install support struts as illustrated

EC centrifugal fans – RadiCal

backward curved, Ø 450



R3G 450-RT03-H1 (Centrifugal fan)

Accessory part: Inlet ring 45901-2-2943
(Material: Plastic)
Not included in scope of delivery
Dimensions: see "Accessories" chapter

Screw-in depth max. 16 mm

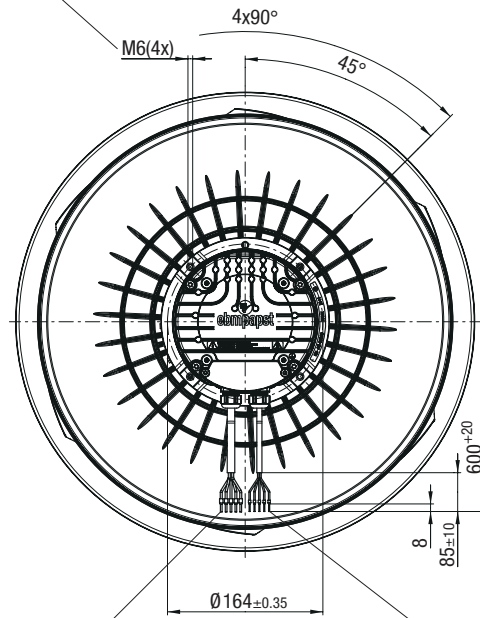
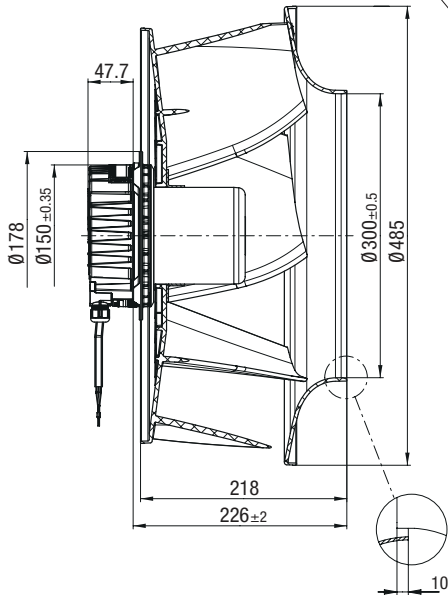

Cable PVC AWG 18,
5x crimped ferrules

Cable PVC AWG 22,
5x crimped ferrules

K3G 450-RT03-H2 (Centrifugal module with support bracket)

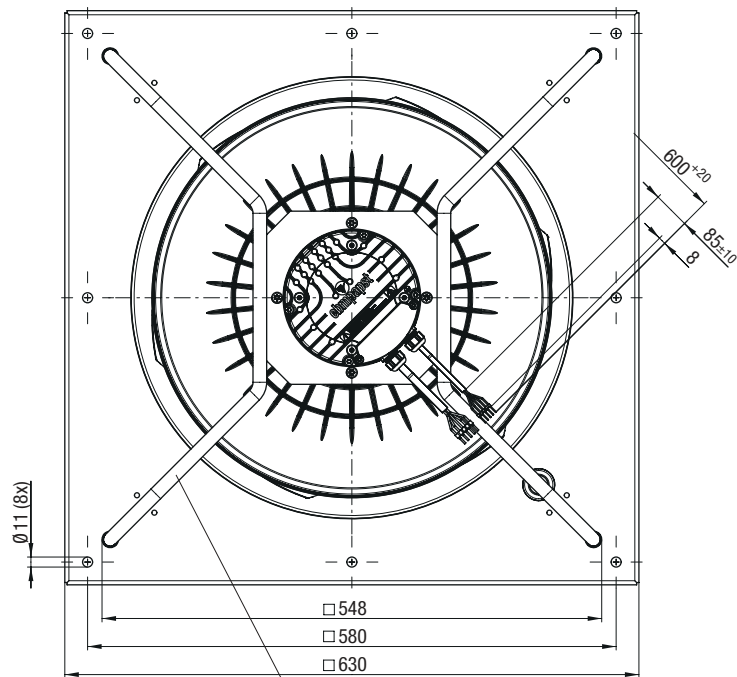
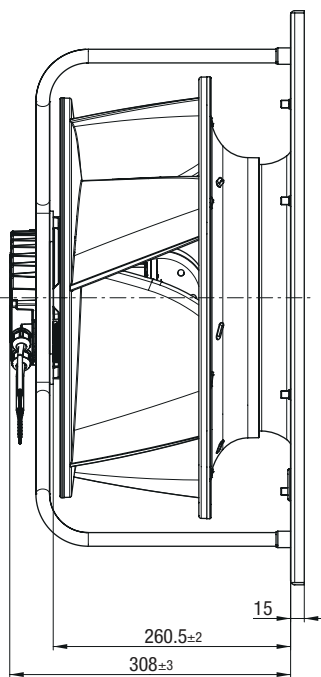

Note installed position! Install support struts as illustrated

EC centrifugal fans – RadiCal

backward curved, Ø 450



R3G 450-RJ74-21 (Centrifugal fan)

Accessory part: Inlet ring 45901-2-2943
(Material: Plastic)
Not included in scope of delivery
Dimensions: see "Accessories" chapter

Screw-in depth max. 16 mm

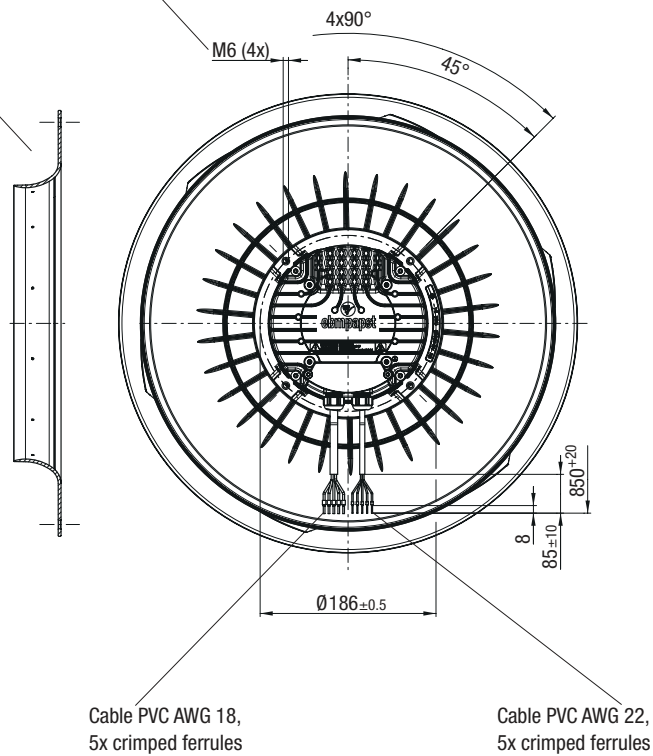
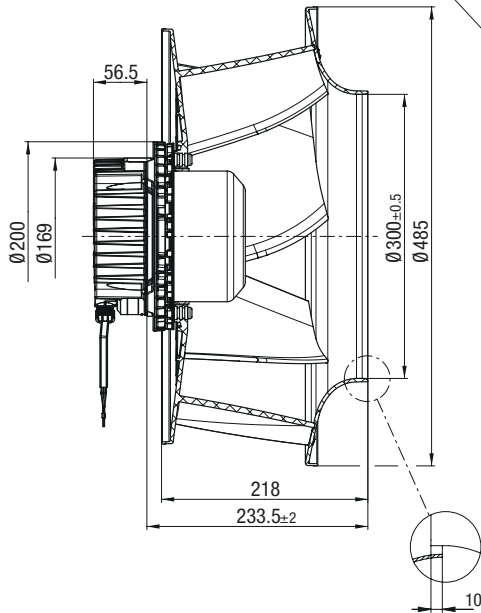

K3G 450-RJ74-21 (Centrifugal module with support bracket)

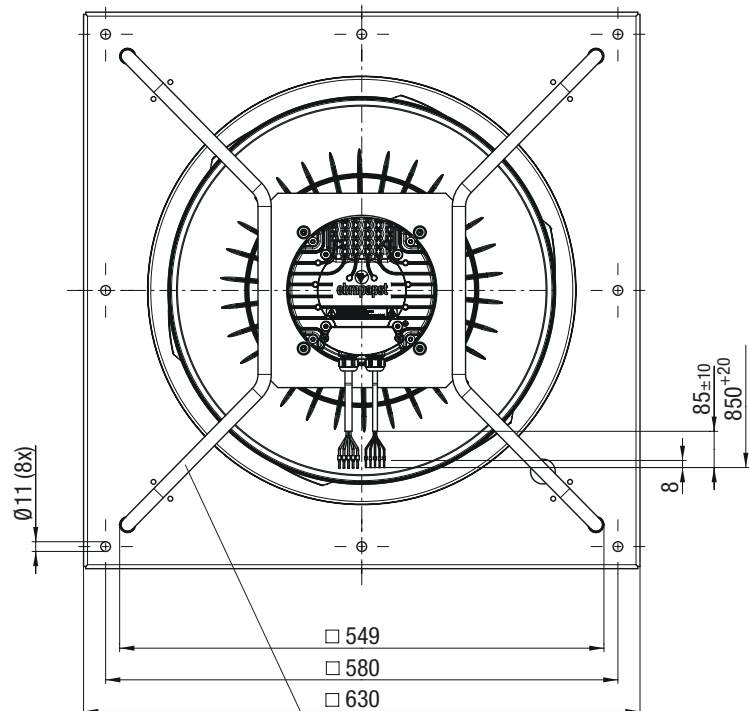
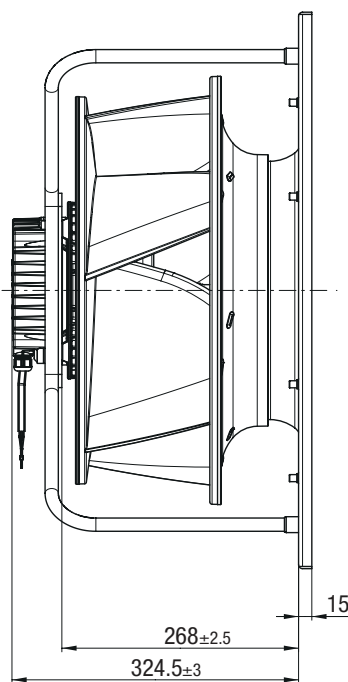

Note installed position! Install support struts as illustrated

EC centrifugal fans – RadiCal

backward curved, Ø 450



R3G 450-RK56-01 (Centrifugal fan)

Accessory part: Inlet ring 45901-2-2943
(Material: Plastic)
Not included in scope of delivery
Dimensions: see "Accessories" chapter

Screw-in depth max. 16 mm

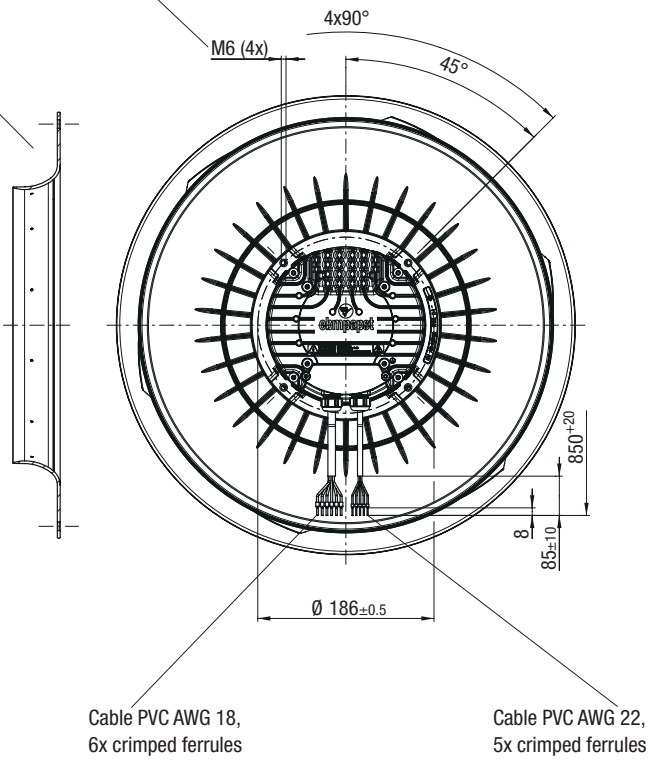
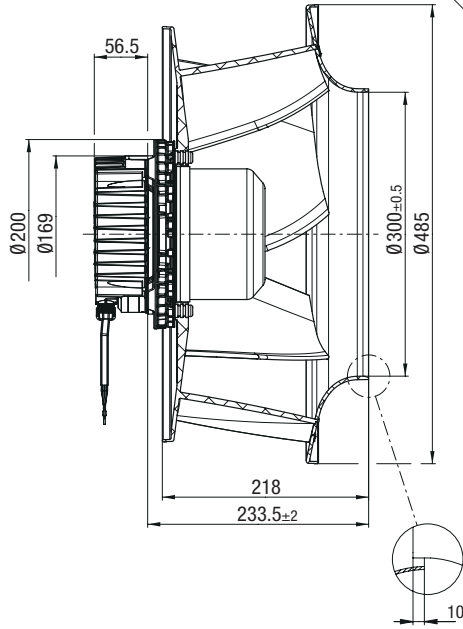

K3G 450-RK56-01 (Centrifugal module with support bracket)

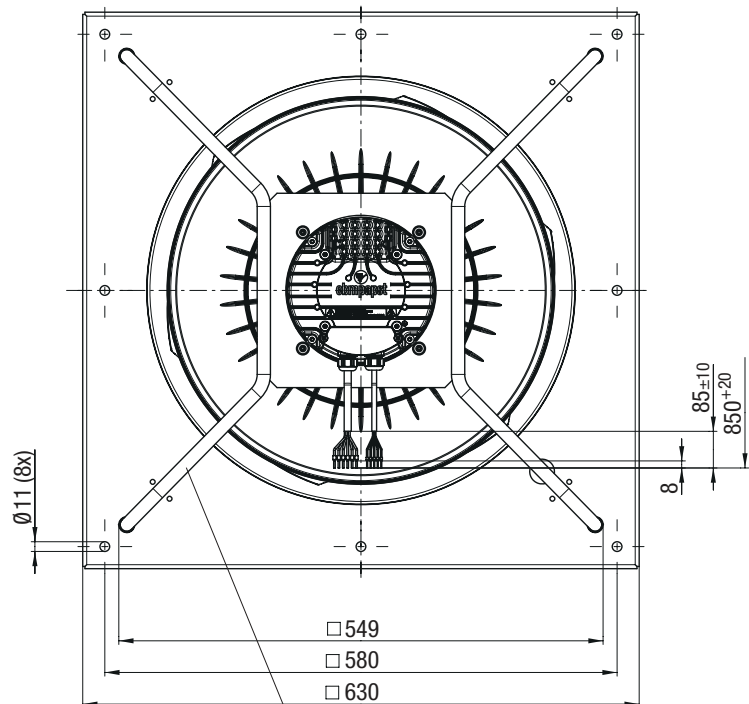
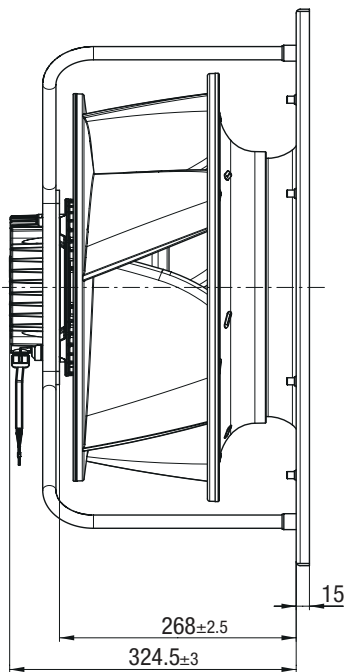

Note installed position! Install support struts as illustrated

EC centrifugal fans – RadiCal

backward curved, Ø 500



- **Material:** Support bracket: Steel, painted black
Support plate: Sheet steel, galvanized
Inlet ring: (A) (B) (C) (D) (E) (F) Plastic; (G) Sheet steel, galvanized
Impeller: Plastic / Rotor: Painted black
Electronics housing: Die-cast aluminium
- **Number of blades:** 7
- **Direction of rotation:** Clockwise viewed toward rotor
- **Degree of protection:** IP 55
- **Insulation class:** "F"
- **Installation position:** Shaft horizontal or rotor on bottom, rotor on top on request
- **Condensation drainage holes:** Rotor side
- **Mode:** Continuous operation (S1)
- **Mounting:** Maintenance-free ball bearings

Nominal data

| Type | Motor | Curve | Nominal voltage range | Frequency | Speed ⁽¹⁾ | Max. Input power ⁽¹⁾ | Max. Input current ⁽¹⁾ | Perm. ambient temp. | Techn. features and connection diagram |
|---------|------------|---------------|-----------------------|-----------|----------------------|---------------------------------|-----------------------------------|---------------------|--|
| Type | Motor | VAC | Hz | rpm | W | A | °C | | |
| *3G 500 | M3G 084-FA | (A) 1~200-277 | 50/60 | 750 | 250 | 1,10 | -25..+60 | P. 147 / RC4) | |
| *3G 500 | M3G 084-GF | (B) 1~200-277 | 50/60 | 900 | 460 | 2,00 | -25..+40 | P. 147 / RC4) | |
| *3G 500 | M3G 112-GA | (C) 1~200-277 | 50/60 | 1100 | 750 | 3,30 | -25..+60 | P. 147 / RC4) | |
| *3G 500 | M3G 112-IA | (D) 3~380-480 | 50/60 | 1350 | 1320 | 2,10 | -25..+50 | P. 148 / RC5) | |
| *3G 500 | M3G 150-FF | (E) 3~380-480 | 50/60 | 1700 | 2600 | 4,00 | -40..+60 | P. 149 / RC6) | |
| *3G 500 | M3G 150-FF | (F) 3~380-480 | 50/60 | 1820 | 3190 | 4,60 | -25..+40 | P. 158 / RC14) | |
| *3G 500 | M3G 150-FF | (G) 3~380-480 | 50/60 | 1900 | 3650 | 5,60 | -40..+40 | P. 153 / RC9) | |

Subject to change

(1) Nominal data at operating point with maximum load and 230 or 400 VAC.

Curves:

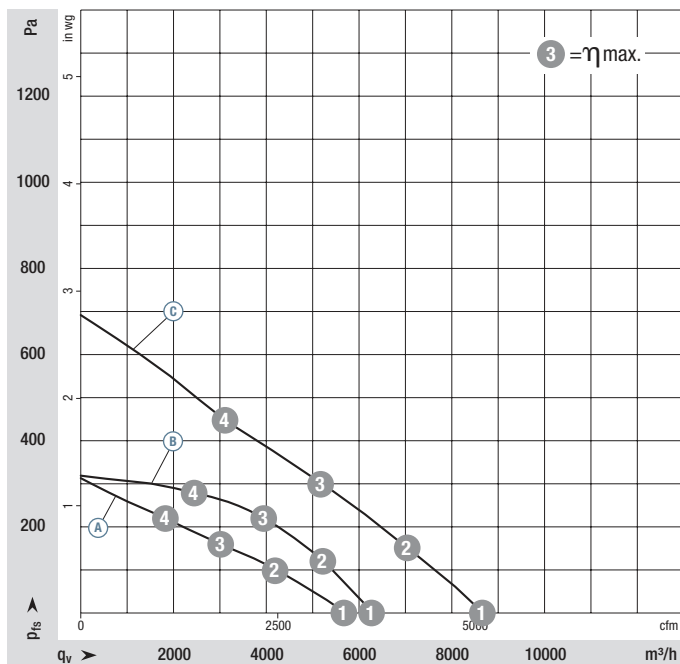

| | n rpm | P _{ed} W | I A | L _{wA} dB(A) |
|-------|-------|-------------------|------|-----------------------|
| (A) 1 | 825 | 226 | 1,00 | 68 |
| (A) 2 | 765 | 250 | 1,10 | 62 |
| (A) 3 | 750 | 250 | 1,10 | 56 |
| (A) 4 | 795 | 250 | 1,10 | 59 |
| (B) 1 | 900 | 301 | 1,32 | 70 |
| (B) 2 | 900 | 410 | 1,79 | 66 |
| (B) 3 | 900 | 460 | 2,00 | 62 |
| (B) 4 | 900 | 397 | 1,73 | 61 |
| (C) 1 | 1250 | 743 | 3,30 | 77 |
| (C) 2 | 1155 | 750 | 3,30 | 73 |
| (C) 3 | 1100 | 750 | 3,30 | 67 |
| (C) 4 | 1155 | 746 | 3,30 | 69 |

Air performance measured according to: ISO 5801, installation category A, with ebm-papst inlet ring without contact protection. Intake-side sound level: L_{wA} according to ISO 13347, L_{pA} measured at 1 m distance from fan axis. The values given are only applicable under the specified measuring conditions and may differ depending on the installation conditions. In the event of deviation from the standard configuration, the parameters must be checked in installed condition. See Page 162 ff. for detailed information.

- **Technical features:** See connection diagram P. 147 ff.
- **EMC:** (A) (B) (C) Interference emission according to EN 61000-6-3
 (D) (E) According to 61000-6-3 (household environment), except EN 61000-3-2 for professionally used equipment with a total rated power greater than 1 kW
 (A) (B) (C) Immunity to interference according to EN 61000-6-2; (D) (E) according to EN 61000-6-2 (industrial environment)
 (A) (B) (C) (D) (E) Circuit feedback according to EN 61000-3-2/3
- **Touch current:** < 3,5 mA according to IEC 60990 (measuring circuit Fig. 4)
- **Cable exit:** (A) (B) (C) (D) Variable
- **Terminal box design:** (E) (F) (G) electrical connection via terminal strip
- **Protection class:** I (with customer connection of protective earth)
- **Conformity with standards:** (A) (B) (C) EN 60335-1, EN 61800-5-1, CE; (D) (E) (F) (G) EN 61800-5-1, CE
- **Approvals:** (A) (B) (C) VDE, UL, CSA, CCC, EAC; (D) (E) (F) (G) UL, CSA, EAC
- **Efficiency:** Ecodesign EU regulation EU 327/2011



Weight Centrifugal fan



Weight Centrifugal module with support bracket

| Centrifugal fan | kg | Centrifugal module with support bracket | kg |
|---------------------------------|------|---|------|
| R3G 500-RS06 -G1 | 8,90 | K3G 500-RS06 -G2 | 18,8 |
| R3G 500-RT04 -H1 | 9,40 | K3G 500-RT04 -H2 | 19,7 |
| R3G 500-RK55 -21 | 13,0 | K3G 500-RK55 -21 | 23,0 |
| R3G 500-RL96 -01 | 15,1 | K3G 500-RL96 -01 | 25,4 |
| R3G 500-RA24 -71 | 21,0 | K3G 500-RA24 -71 | 35,0 |
| R3G 500-RA26 -C1 ⁽²⁾ | 28,0 | K3G 500-RA26 -C1 ⁽²⁾ | 43,5 |
| R3G 500-RA28 -03 | 21,0 | K3G 500-RA28 -03 | 35,0 |

(2) with Aktive-PFC

Curves:

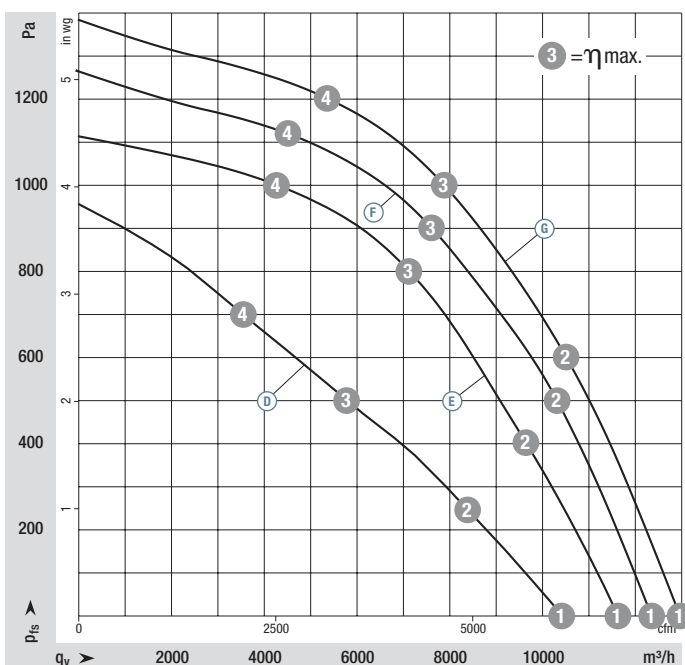

Air performance measured according to: ISO 5801, installation category A, with ebm-papst inlet ring without contact protection. Intake-side sound level: L_{WA} according to ISO 13347, L_{pA} measured at 1 m distance from fan axis. The values given are only applicable under the specified measuring conditions and may differ depending on the installation conditions. In the event of deviation from the standard configuration, the parameters must be checked in installed condition. See Page 162 ff. for detailed information.

| | n rpm | P _{ed} W | I A | L _{WA} dB(A) |
|-------|-------|-------------------|------|-----------------------|
| (D) 1 | 1495 | 1215 | 1,91 | 82 |
| (D) 2 | 1405 | 1320 | 2,10 | 77 |
| (D) 3 | 1350 | 1320 | 2,10 | 71 |
| (D) 4 | 1435 | 1300 | 2,05 | 77 |
| (E) 1 | 1700 | 1848 | 2,90 | 86 |
| (E) 2 | 1700 | 2408 | 3,72 | 83 |
| (E) 3 | 1700 | 2600 | 4,00 | 78 |
| (E) 4 | 1700 | 2378 | 3,68 | 80 |
| (F) 1 | 1820 | 2280 | 3,30 | 88 |
| (F) 2 | 1820 | 3045 | 4,40 | 84 |
| (F) 3 | 1820 | 3190 | 4,60 | 79 |
| (F) 4 | 1820 | 2730 | 3,95 | 84 |
| (G) 1 | 1900 | 2554 | 3,95 | 89 |
| (G) 2 | 1900 | 3485 | 5,34 | 85 |
| (G) 3 | 1900 | 3650 | 5,60 | 80 |
| (G) 4 | 1900 | 3248 | 4,98 | 84 |

EC centrifugal fans – RadiCal

backward curved, Ø 500

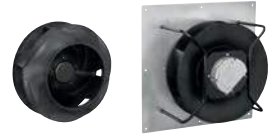

R3G 500-RS06-G1 (Centrifugal fan)

Accessory part: Inlet ring 50901-2-2943
Not included in scope of delivery
Dimensions: see "Accessories" chapter

Screw-in depth max. 16 mm

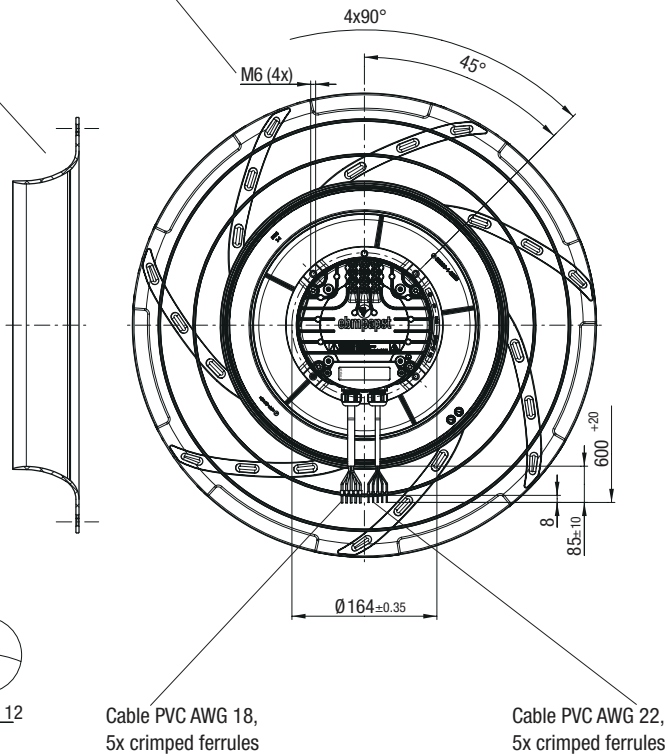
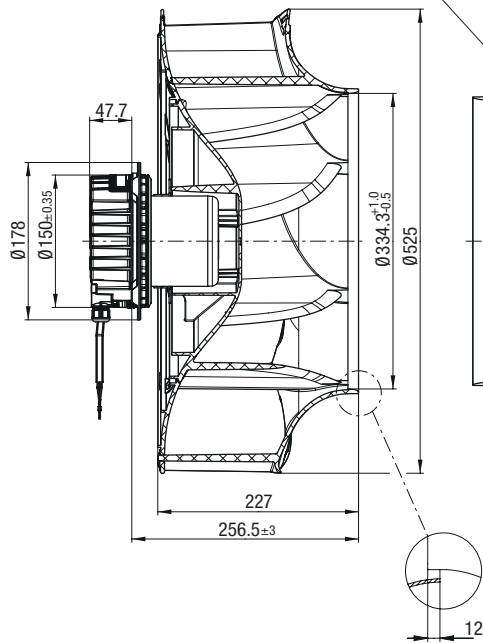

K3G 500-RS06-G2 (Centrifugal module with support bracket)

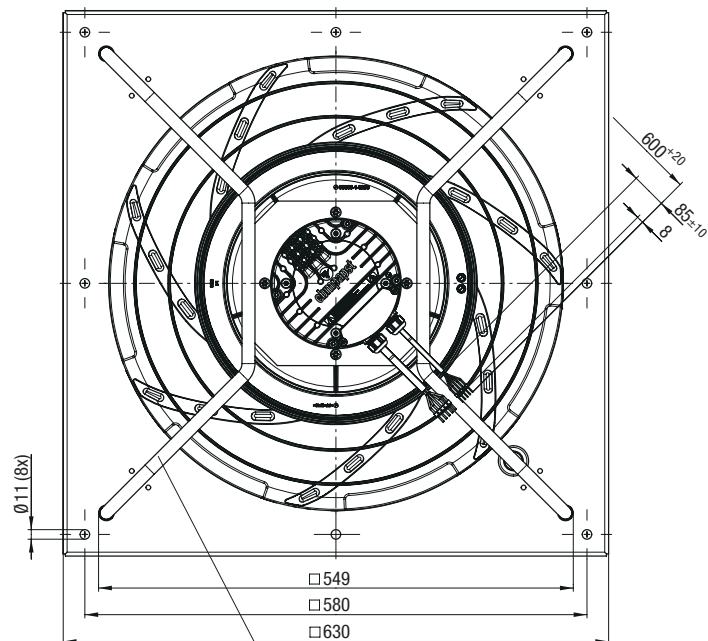
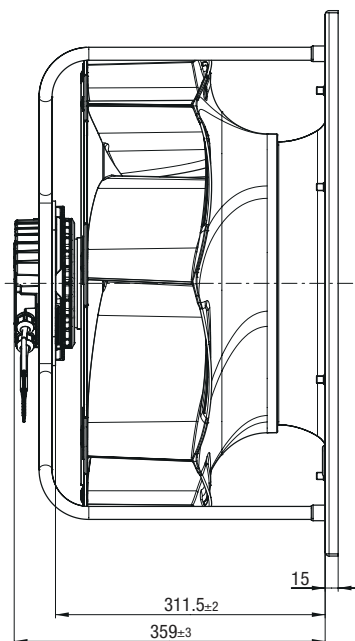

Note installed position! Install support struts as illustrated

EC centrifugal fans – RadiCal

backward curved, Ø 500

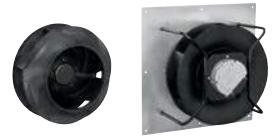

R3G 500-RT04-H1 (Centrifugal fan)

Accessory part: Inlet ring 50901-2-2943
Not included in scope of delivery
Dimensions: see "Accessories" chapter

Screw-in depth max. 16 mm

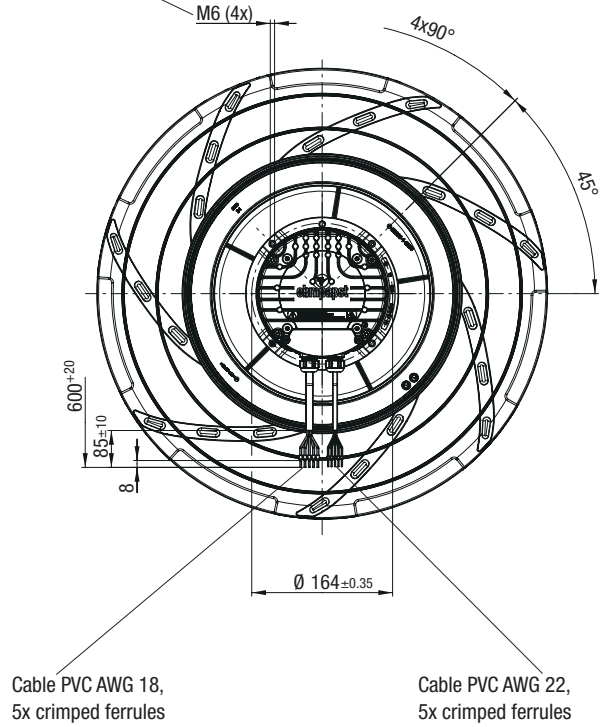
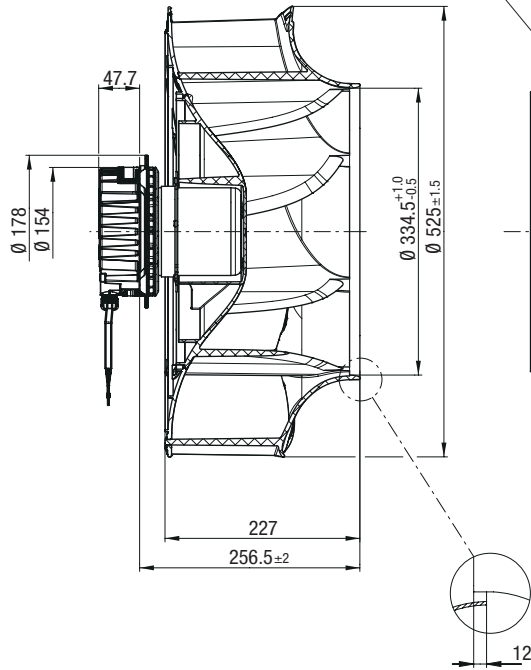

K3G 500-RT04-H2 (Centrifugal module with support bracket)

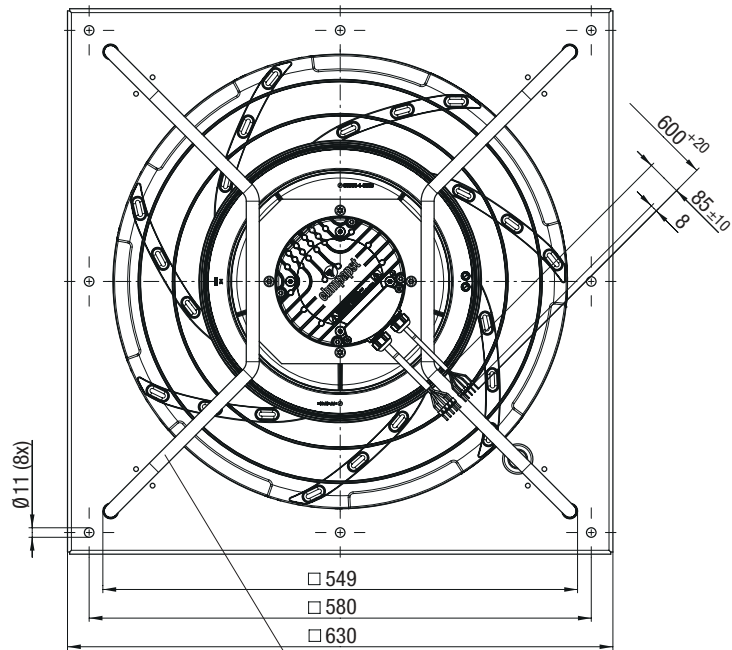
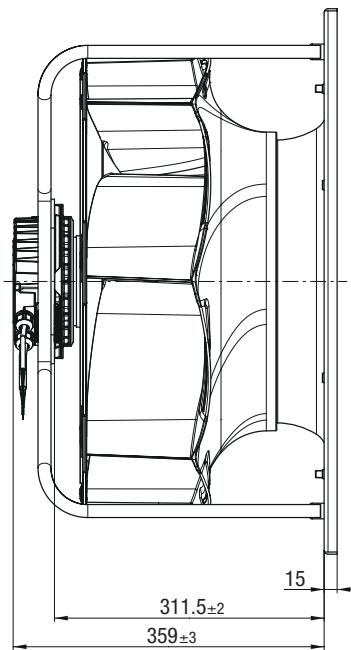

Note installed position! Install support struts as illustrated

EC centrifugal fans – RadiCal

backward curved, Ø 500

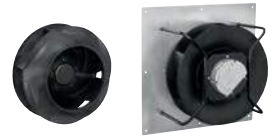

R3G 500-RK55-21 (Centrifugal fan)

Accessory part: Inlet ring 50901-2-2943
Not included in scope of delivery
Dimensions: see "Accessories" chapter

Screw-in depth max. 16 mm

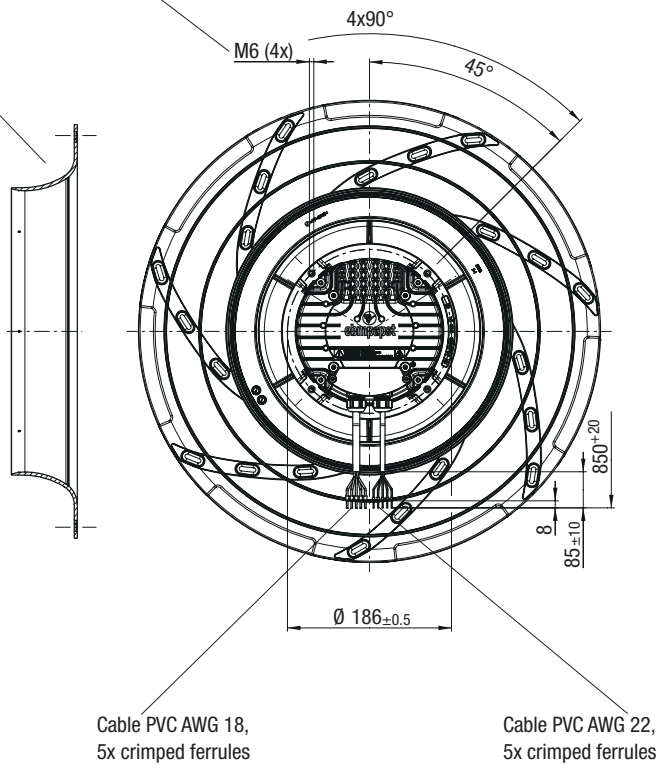
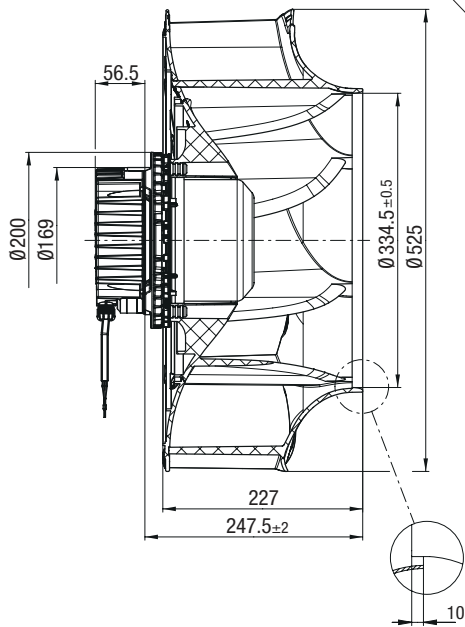

K3G 500-RK55-21 (Centrifugal module with support bracket)

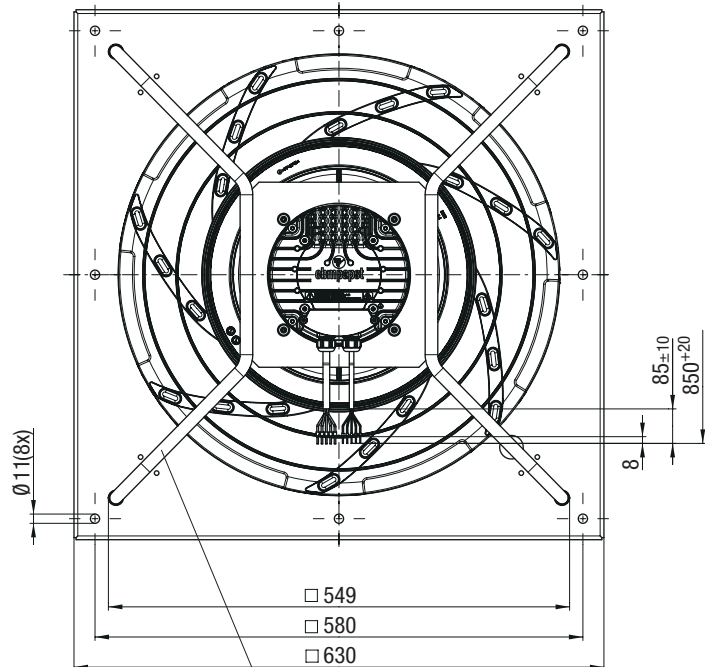
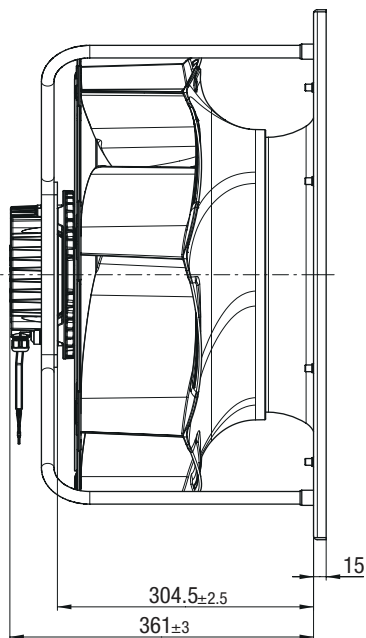

Note installed position! Install support struts as illustrated

EC centrifugal fans – RadiCal

backward curved, Ø 500



R3G 500-RL96-01 (Centrifugal fan)

Accessory part: Inlet ring 50901-2-2943
Not included in scope of delivery
Dimensions: see "Accessories" chapter

Screw-in depth max. 16 mm

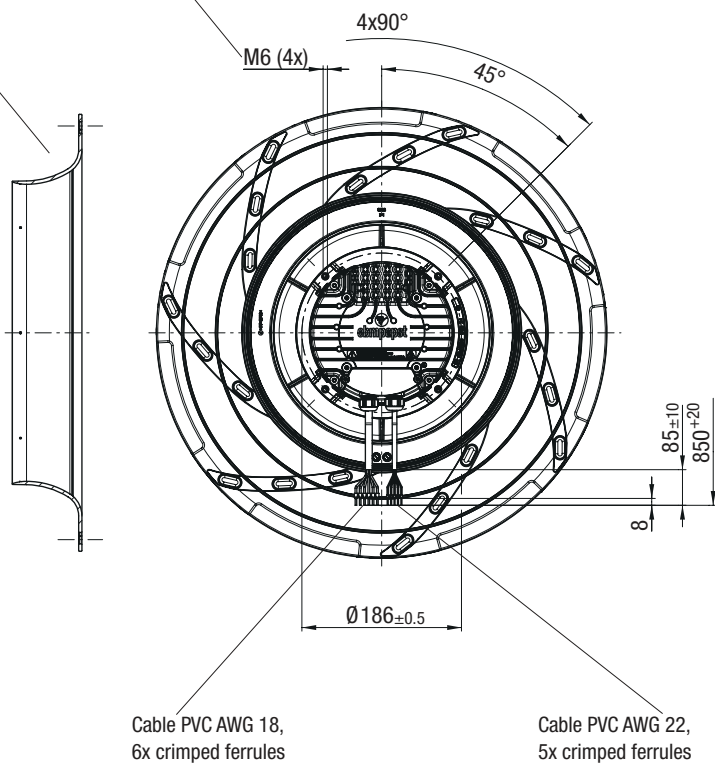
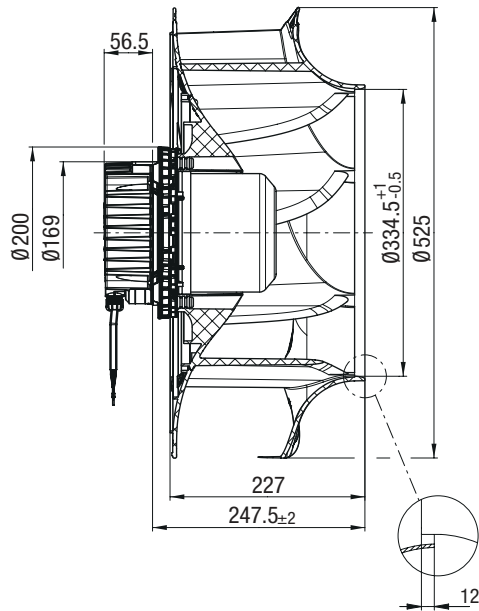

K3G 500-RL96-01 (Centrifugal module with support bracket)

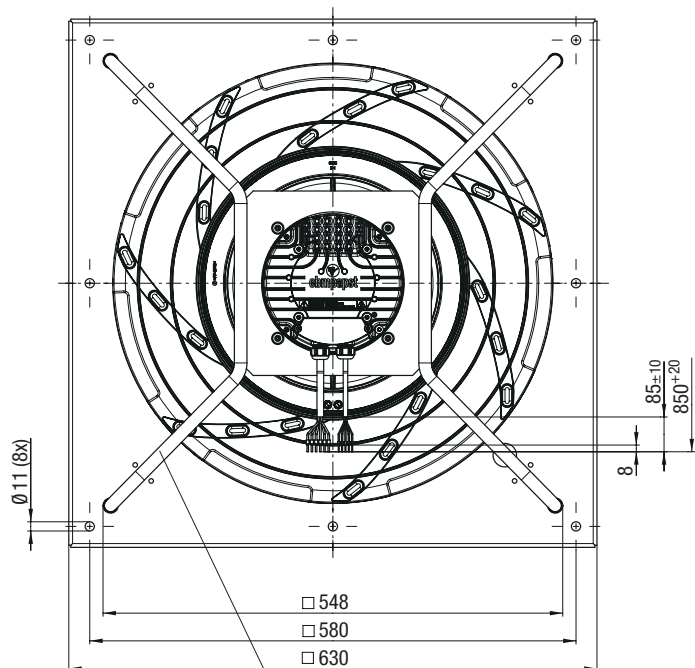
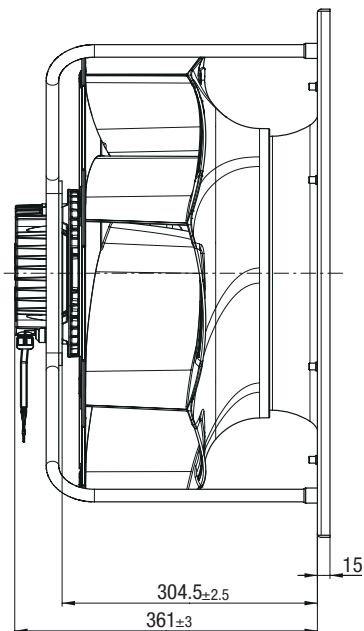

Note installed position! Install support struts as illustrated

EC centrifugal fans – RadiCal

backward curved, Ø 500



R3G 500-RA24-71 (Centrifugal fan)

Accessory part: Inlet ring 50901-2-2943
Not included in scope of delivery
Dimensions: see "Accessories" chapter

Screw-in depth max. 25 mm

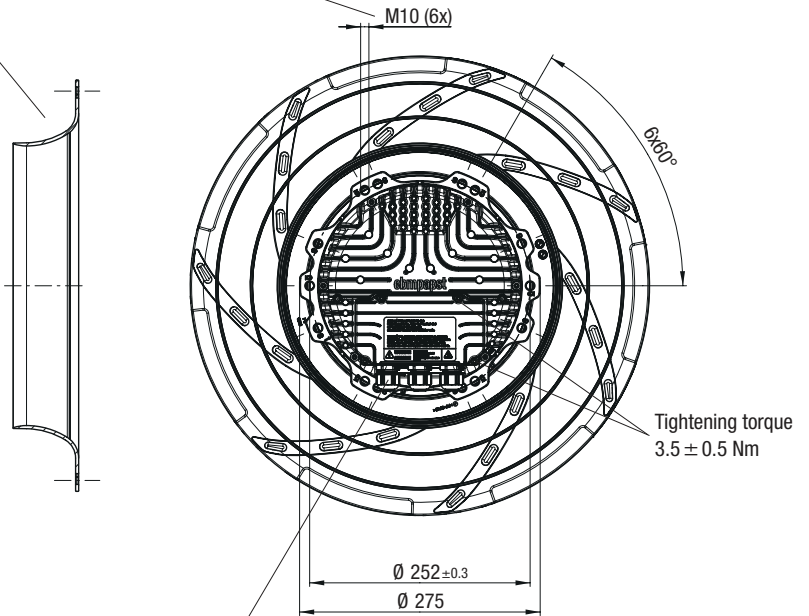
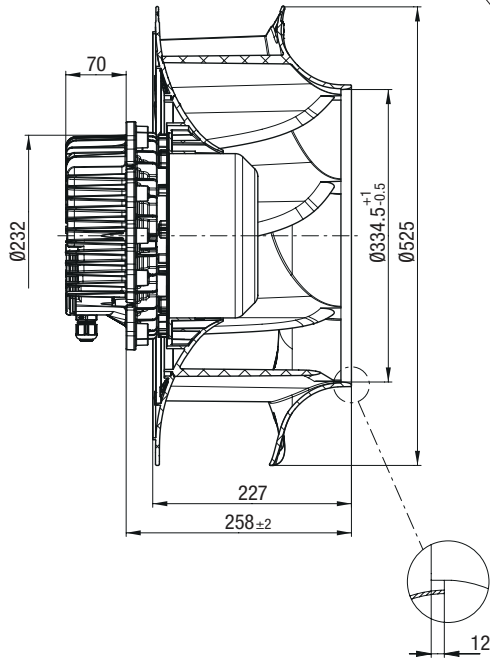

Cable gland M20x1.5 (3x):
Cable diameter min. 4 mm, max. 10 mm
Tightening torque 4 ± 0.6 Nm

K3G 500-RA24-71 (Centrifugal module with support bracket)

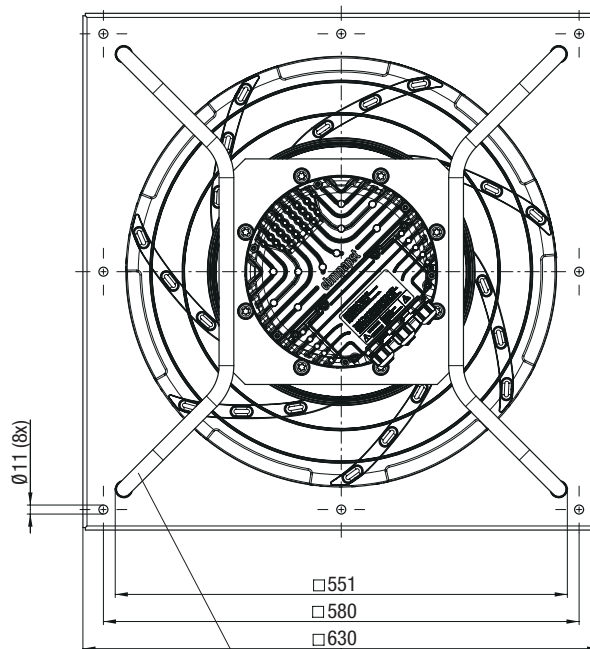
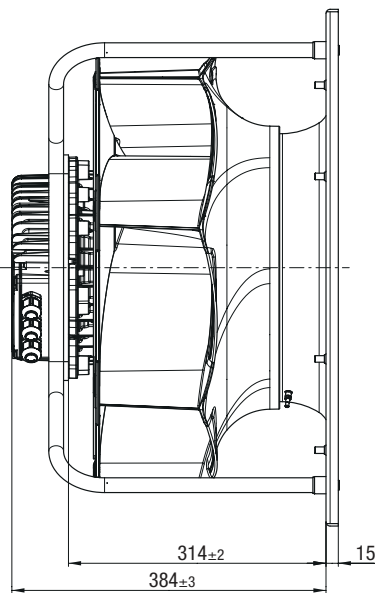

Note installed position! Install support struts as illustrated

EC centrifugal fans – RadiCal

backward curved, Ø 500 (with Aktive-PFC)



R3G 500-RA26-C1 (Centrifugal fan)

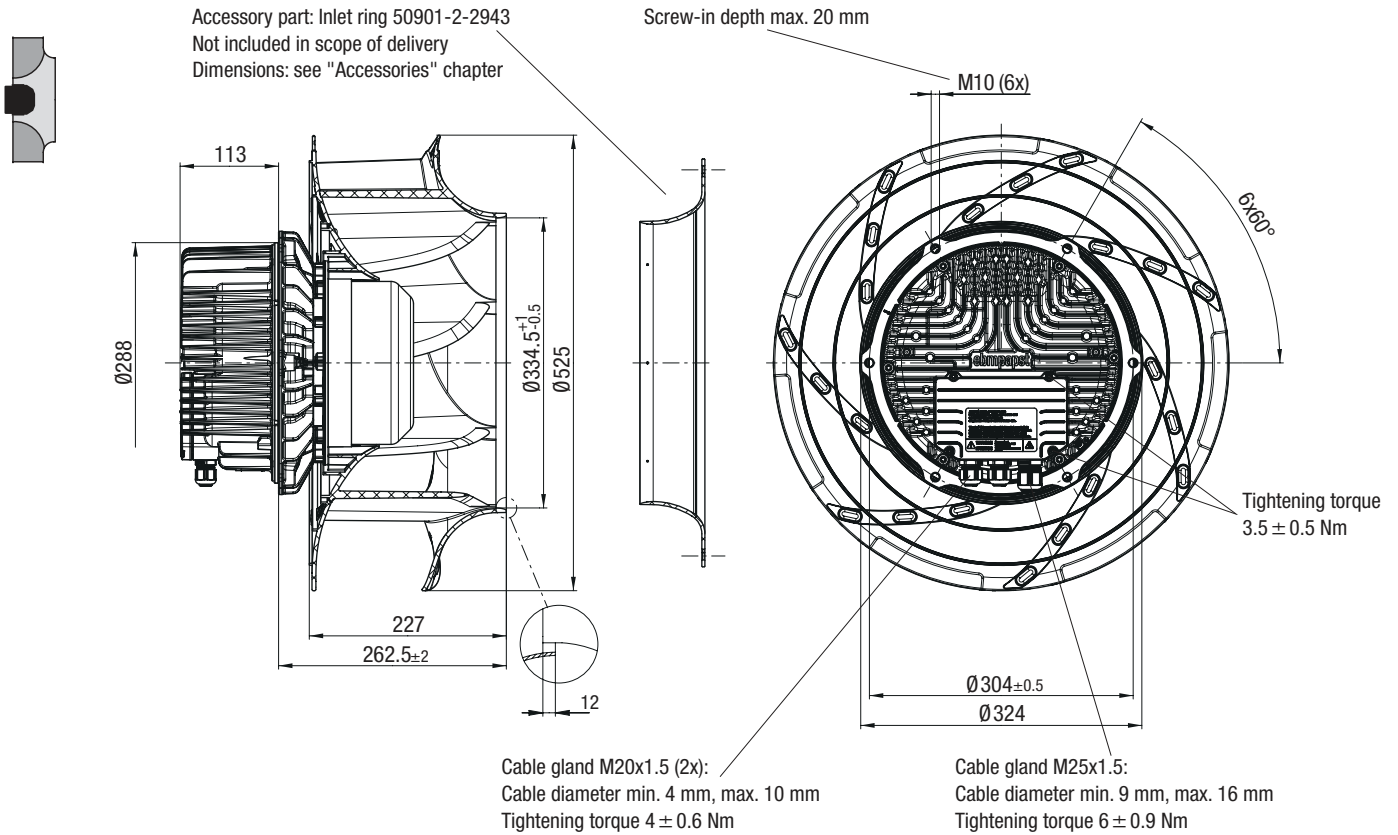

K3G 500-RA26-C1 (Centrifugal module with support bracket)

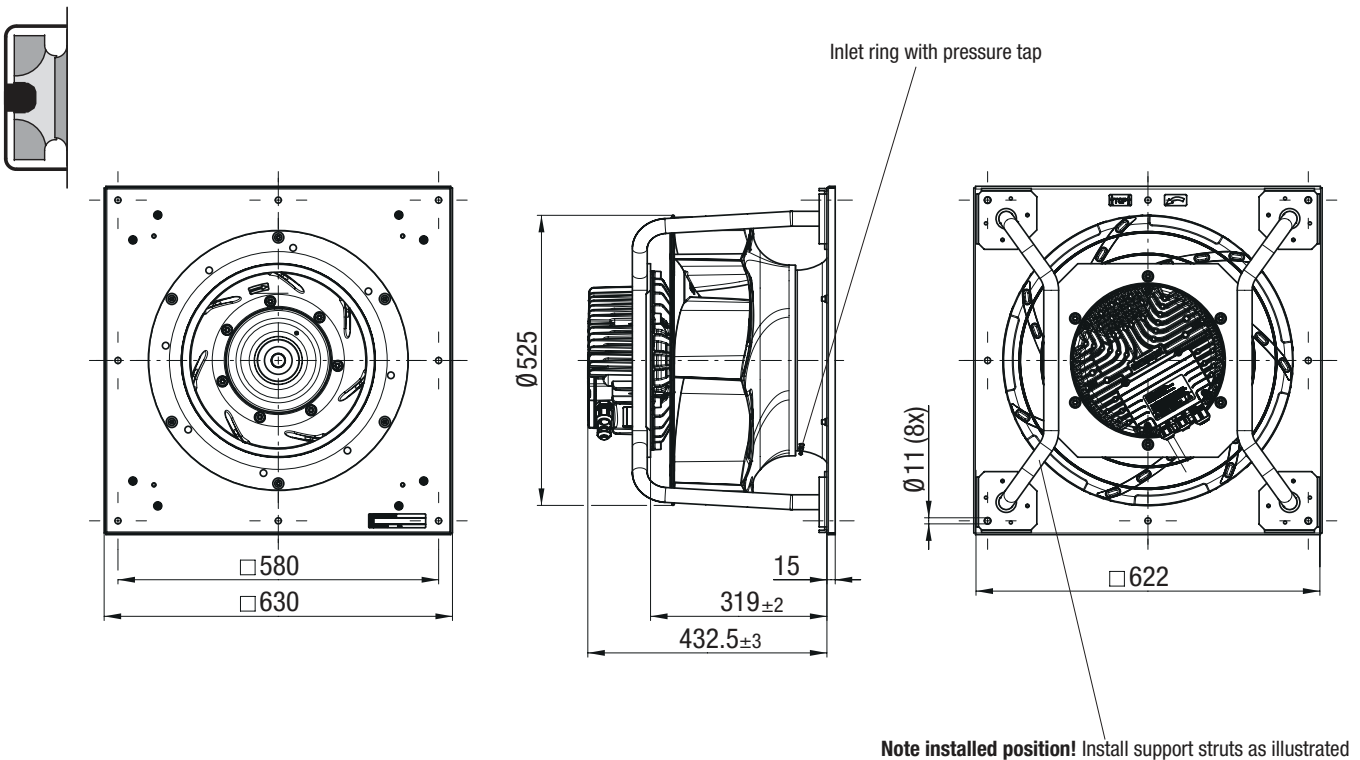

EC centrifugal fans – RadiCal

backward curved, Ø 500



R3G 500-RA28-03 (Centrifugal fan)



Accessory part: Inlet ring 50901-2-2943
Not included in scope of delivery
Dimensions: see "Accessories" chapter

Screw-in depth max. 20 mm

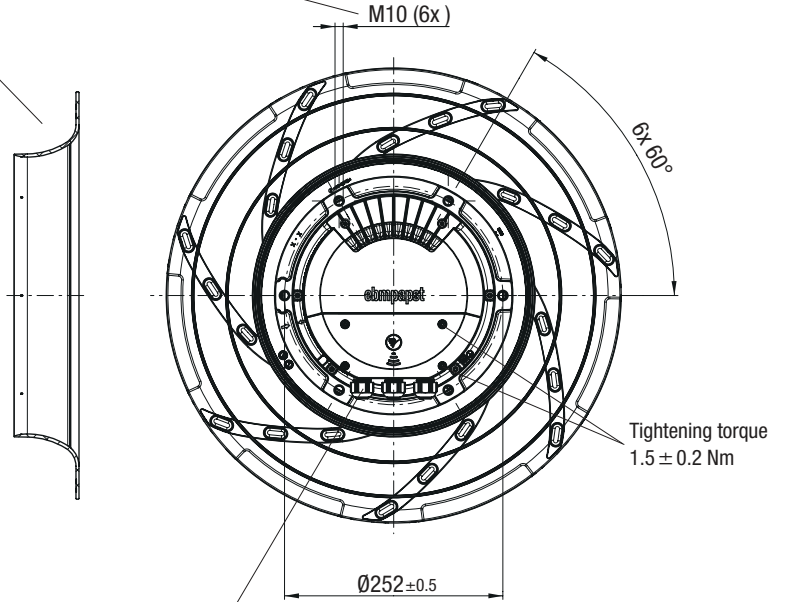
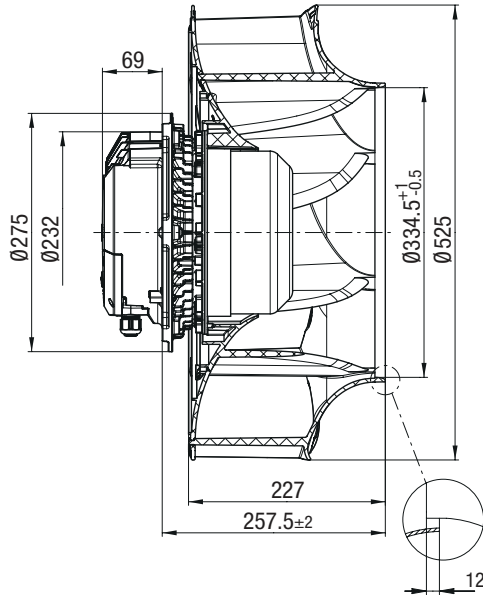

Cable gland M20x1.5 (3x):
Cable diameter min. 4 mm, max. 10 mm
Tightening torque 2 ± 0.2 Nm

K3G 500-RA28-03 (Centrifugal module with support bracket)



Attachment for FlowGrid

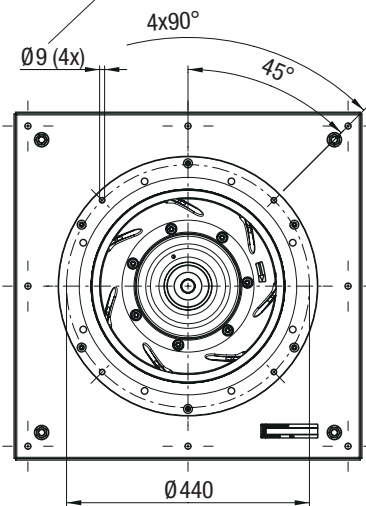

Note installed position! Install support struts as illustrated

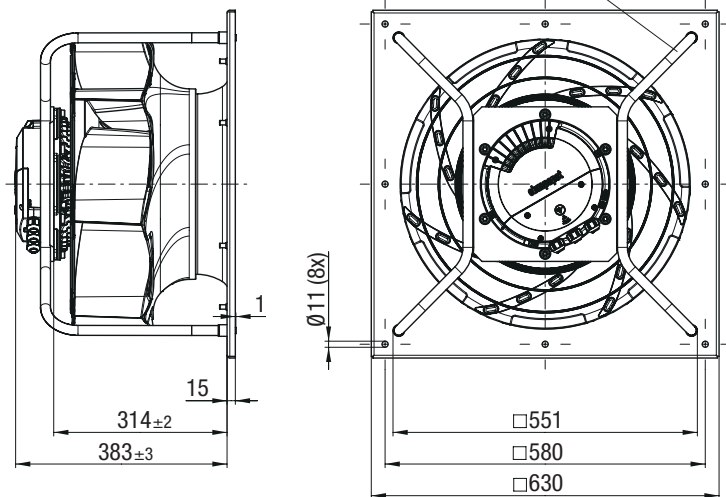

EC centrifugal fans – RadiCal

backward curved, Ø 560



- **Material:** Support bracket: Steel, painted black
Support plate and Inlet ring: Sheet steel, galvanized
Impeller: Plastic / Rotor: Painted black
Electronics housing: Die-cast aluminium
- **Number of blades:** 6
- **Direction of rotation:** Clockwise viewed toward rotor
- **Degree of protection:** IP 55
- **Insulation class:** "F"
- **Installation position:** Shaft horizontal or rotor on bottom, rotor on top on request
- **Condensation drainage holes:** Rotor side
- **Mode:** Continuous operation (S1)
- **Mounting:** Maintenance-free ball bearings

Nominal data

| Type | Motor | Curve | Nominal voltage range | Frequency | Speed ⁽¹⁾ | Max. Input power ⁽¹⁾ | Max. Input current ⁽¹⁾ | Perm. ambient temp. | Techn. features and connection diagram |
|---------|------------|-------------|-----------------------|-----------|----------------------|---------------------------------|-----------------------------------|---------------------|--|
| Type | Motor | VAC | Hz | rpm | W | A | °C | | |
| *3G 560 | M3G 150-FF | Ⓐ 1~200-277 | 50/60 | 1340 | 1500 | 6,70 | -25..+55 | P. 150 / RC7) | |
| *3G 560 | M3G 150-FF | Ⓑ 3~380-480 | 50/60 | 1540 | 2360 | 3,65 | -40..+60 | P. 149 / RC6) | |
| *3G 560 | M3G 150-IF | Ⓒ 3~380-480 | 50/60 | 1650 | 2900 | 4,43 | -40..+55 | P. 149 / RC6) | |
| *3G 560 | M3G 150-IF | Ⓓ 3~380-480 | 50/60 | 1660 | 3190 | 4,60 | -25..+40 | P. 158 / RC14) | |
| *3G 560 | M3G 150-FF | Ⓔ 3~380-480 | 50/60 | 1750 | 3700 | 5,70 | -40..+40 | P. 153 / RC9) | |

Subject to change

(1) Nominal data at operating point with maximum load and 230 or 400 VAC.

Curves:

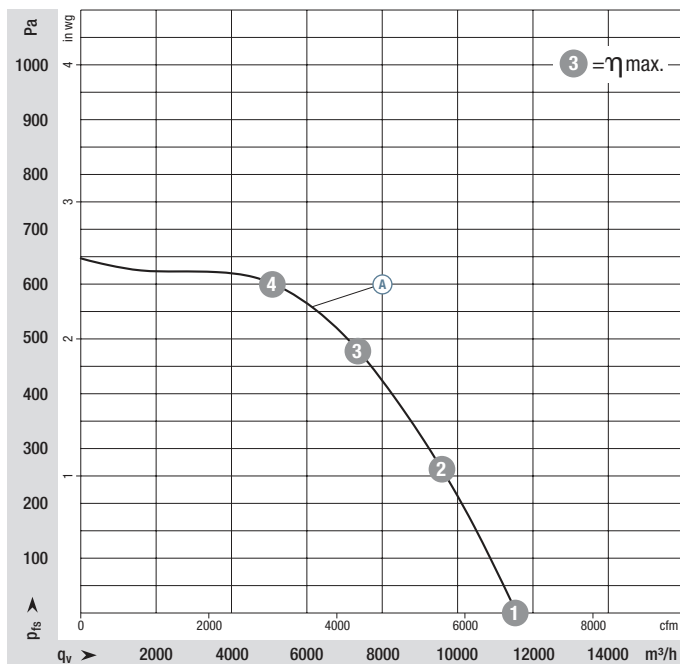

| | n rpm | P _{ed} W | I A | L _{wA} dB(A) |
|-----|-------|-------------------|------|-----------------------|
| Ⓐ ① | 1340 | 1145 | 5,03 | 83 |
| Ⓐ ② | 1340 | 1469 | 6,46 | 79 |
| Ⓐ ③ | 1340 | 1500 | 6,70 | 74 |
| Ⓐ ④ | 1340 | 1480 | 6,47 | 77 |

Air performance measured according to: ISO 5801, installation category A, with ebm-papst inlet ring without contact protection. Intake-side sound level: L_{wA} according to ISO 13347, L_{pA} measured at 1 m distance from fan axis. The values given are only applicable under the specified measuring conditions and may differ depending on the installation conditions. In the event of deviation from the standard configuration, the parameters must be checked in installed condition. See Page 162 ff. for detailed information.

- **Technical features:** See connection diagram P. 149 ff.
- **EMC:** (B) (C) Interference emission according to EN 61000-6-3 (household environment), except EN 61000-3-2 for professionally used equipment with a total rated power greater than 1 kW
 - (A) (B) (C) Immunity to interference according to EN 61000-6-2 (industrial environment)
 - (B) (C) Circuit feedback according to EN 61000-3-2/3
- **Touch current:** < 3,5 mA according to IEC 60990 (measuring circuit Fig. 4)
- **Terminal box design:** electrical connection via terminal strip
- **Protection class:** I (with customer connection of protective earth)
- **Conformity with standards:** EN 61800-5-1, CE
- **Approvals:** (A) (B) (C) (D) (E) UL, CSA, EAC
- **Efficiency:** Ecodesign EU regulation EU 327/2011



Weight Centrifugal fan

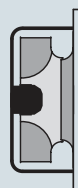

Weight Centrifugal module with support bracket

| Centrifugal fan | kg | Centrifugal module with support bracket | kg |
|---------------------------------|------|---|------|
| R3G 560-RA25 -21 | 22,5 | K3G 560-RA25 -21 | 44,6 |
| R3G 560-RA25 -71 | 22,4 | K3G 560-RA25 -71 | 42,0 |
| R3G 560-RB31 -71 | 26,5 | K3G 560-RB31 -71 | 46,7 |
| R3G 560-RB27 -C1 ⁽²⁾ | 33,5 | K3G 560-RB27 -C1 ⁽²⁾ | 58,0 |
| R3G 560-RA24 -03 | 22,7 | K3G 560-RA24 -03 | 43,3 |

(2) with Aktive-PFC

Curves:

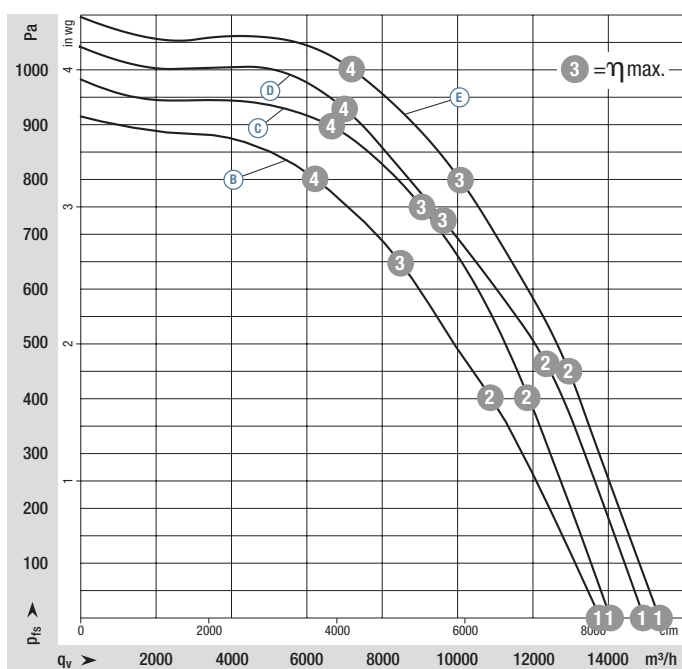

| | n rpm | P _{ed} W | I A | L _{wA} dB(A) |
|-------|-------|-------------------|------|-----------------------|
| (B) 1 | 1540 | 1840 | 2,89 | 86 |
| (B) 2 | 1540 | 2296 | 3,56 | 81 |
| (B) 3 | 1540 | 2360 | 3,65 | 78 |
| (B) 4 | 1540 | 2313 | 3,58 | 80 |
| (C) 1 | 1650 | 2030 | 3,17 | 87 |
| (C) 2 | 1650 | 2695 | 4,16 | 81 |
| (C) 3 | 1650 | 2900 | 4,43 | 77 |
| (C) 4 | 1650 | 2769 | 4,28 | 81 |
| (D) 1 | 1710 | 2250 | 3,30 | 87 |
| (D) 2 | 1710 | 3120 | 4,50 | 82 |
| (D) 3 | 1660 | 3190 | 4,60 | 80 |
| (D) 4 | 1690 | 3180 | 4,60 | 82 |
| (E) 1 | 1750 | 2466 | 3,80 | 89 |
| (E) 2 | 1750 | 3326 | 5,08 | 85 |
| (E) 3 | 1750 | 3700 | 5,70 | 83 |
| (E) 4 | 1750 | 3517 | 5,36 | 85 |

Air performance measured according to: ISO 5801, installation category A, with ebm-papst inlet ring without contact protection. Intake-side sound level: L_{wA} according to ISO 13347, L_{pA} measured at 1 m distance from fan axis. The values given are only applicable under the specified measuring conditions and may differ depending on the installation conditions. In the event of deviation from the standard configuration, the parameters must be checked in installed condition. See Page 162 ff. for detailed information.

EC centrifugal fans – RadiCal

backward curved, Ø 560



R3G 560-RA25-21 (Centrifugal fan)

Accessory part: Inlet ring 54482-2-4013
Not included in scope of delivery
Dimensions: see "Accessories" chapter

Screw-in depth max. 25 mm

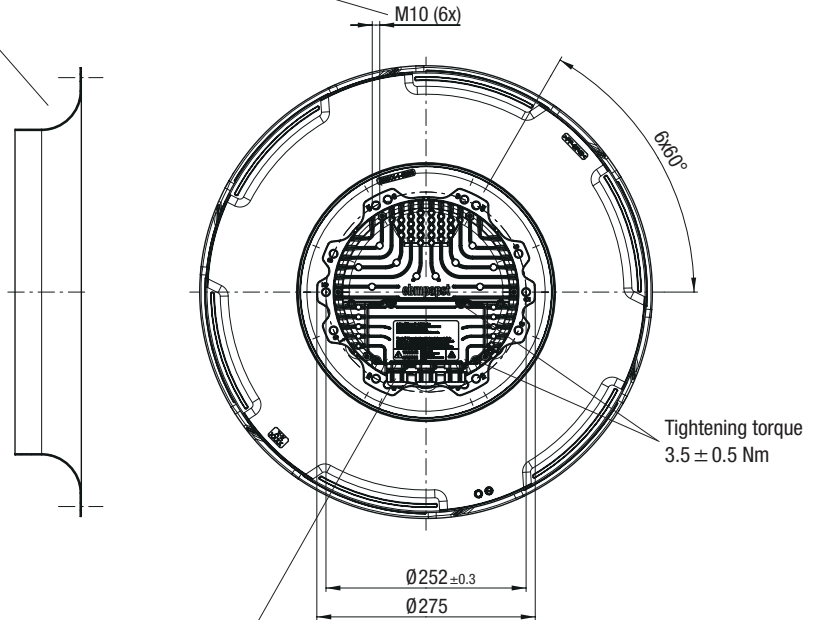
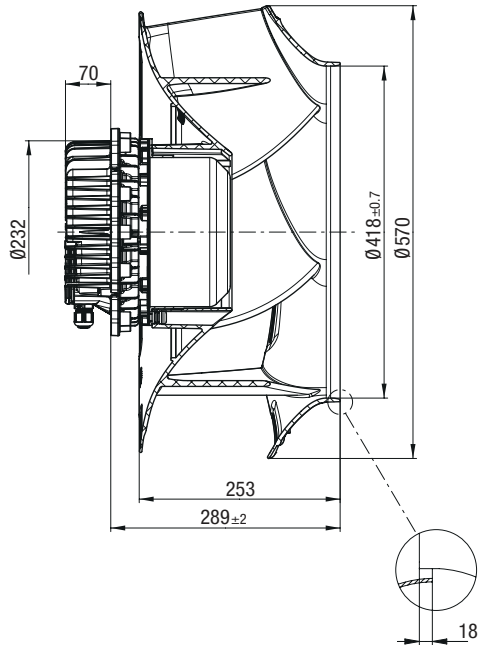

Cable gland M20x1.5 (3x):
Cable diameter min. 4 mm, max. 10 mm
Tightening torque 4 ± 0.6 Nm

K3G 560-RA25-21 (Centrifugal module with support bracket)

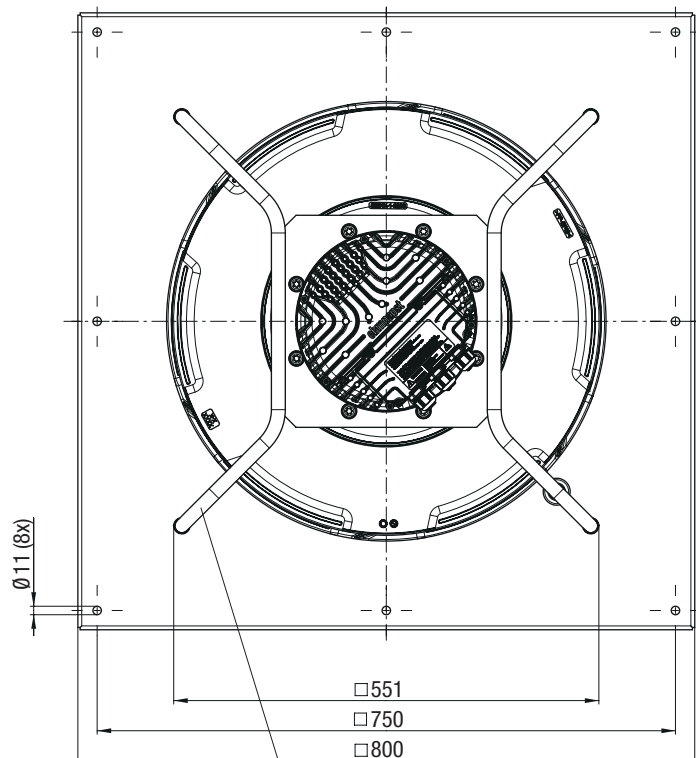
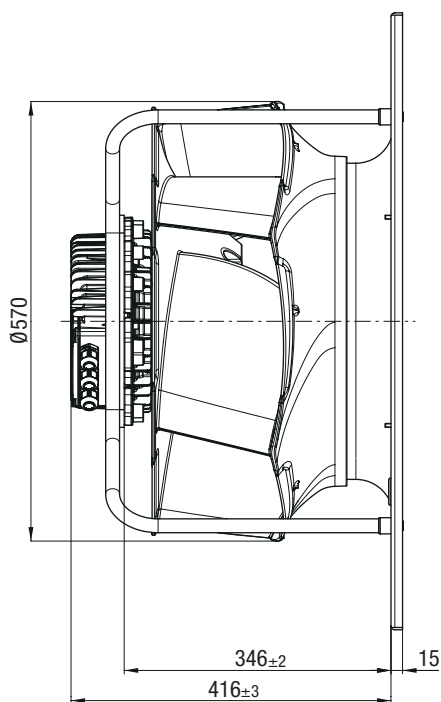

Note installed position! Install support struts as illustrated

EC centrifugal fans – RadiCal

backward curved, Ø 560



R3G 560-RA25-71 (Centrifugal fan)

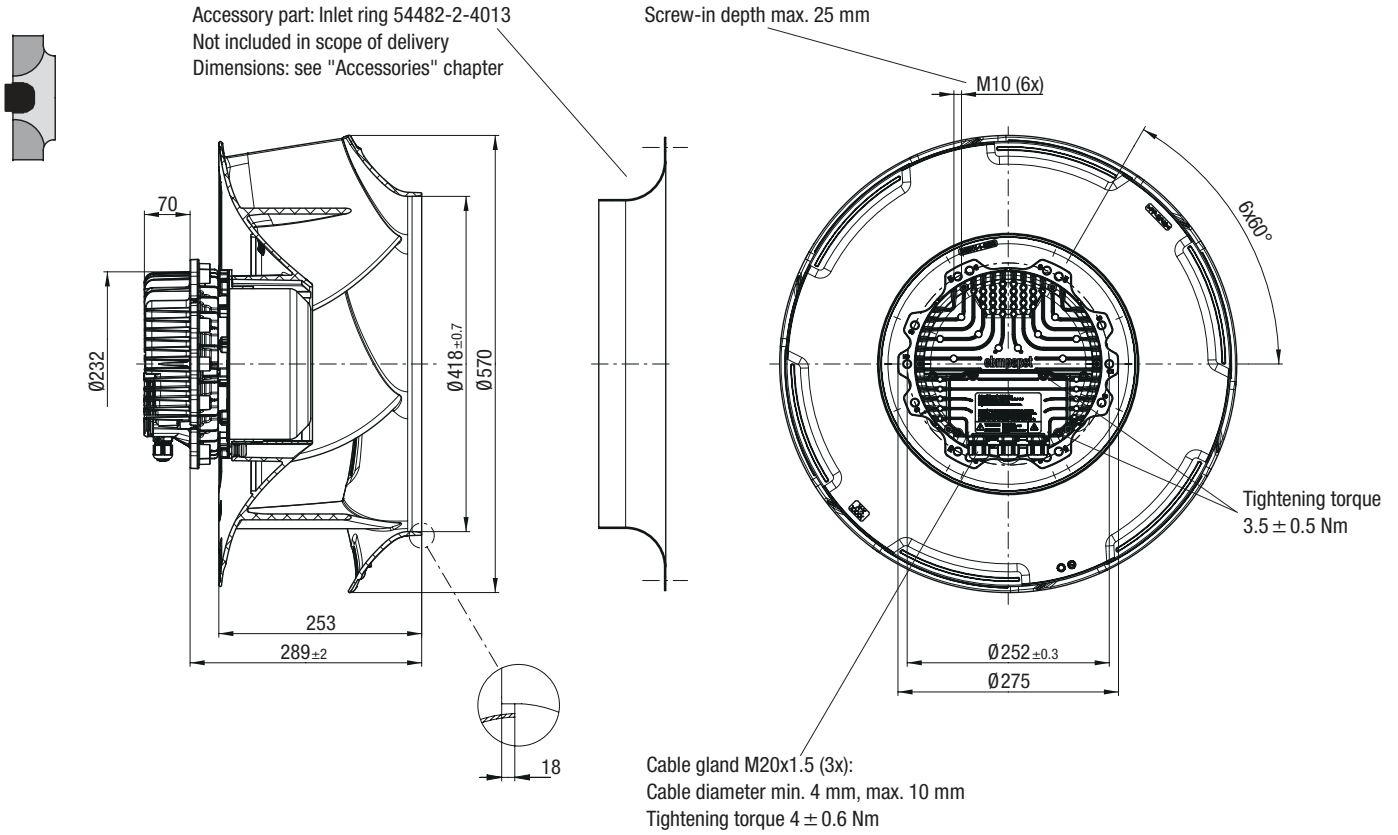

K3G 560-RA25-71 (Centrifugal module with support bracket)

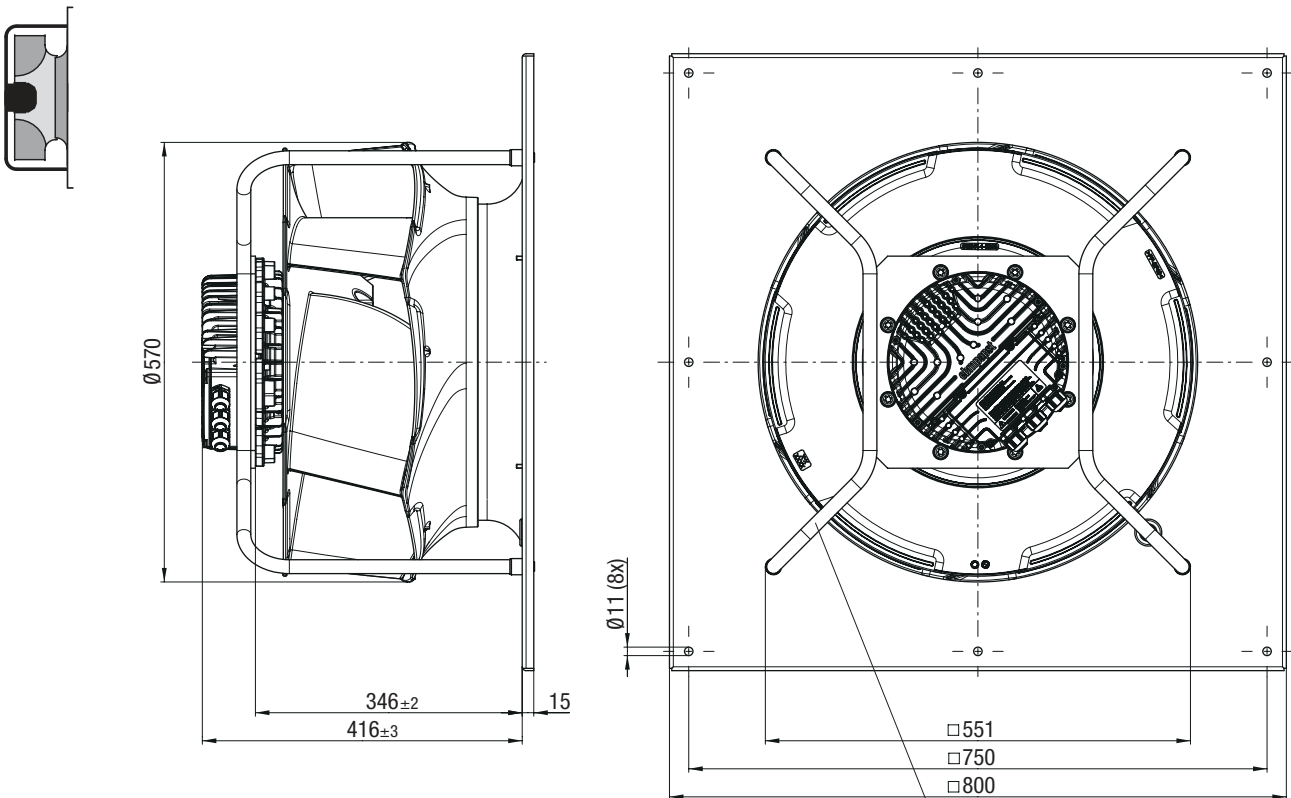

Note installed position! Install support struts as illustrated

EC centrifugal fans – RadiCal

backward curved, Ø 560



R3G 560-RB31-71 (Centrifugal fan)



Accessory part: Inlet ring 54482-2-4013
Not included in scope of delivery
Dimensions: see "Accessories" chapter

Screw-in depth max. 25 mm

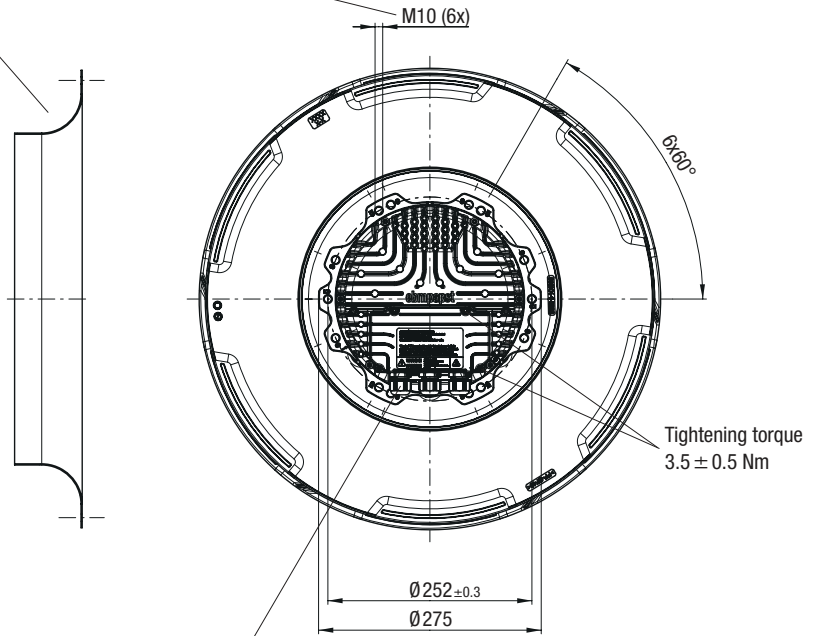
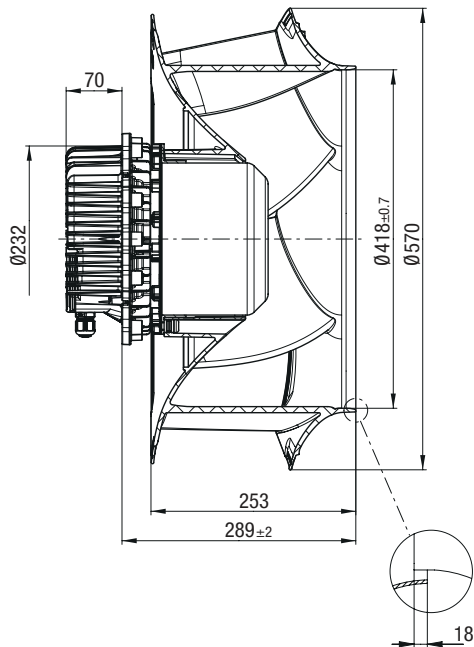

Cable gland M20x1.5 (3x):
Cable diameter min. 4 mm, max. 10 mm
Tightening torque 4 ± 0.6 Nm

K3G 560-RB31-71 (Centrifugal module with support bracket)

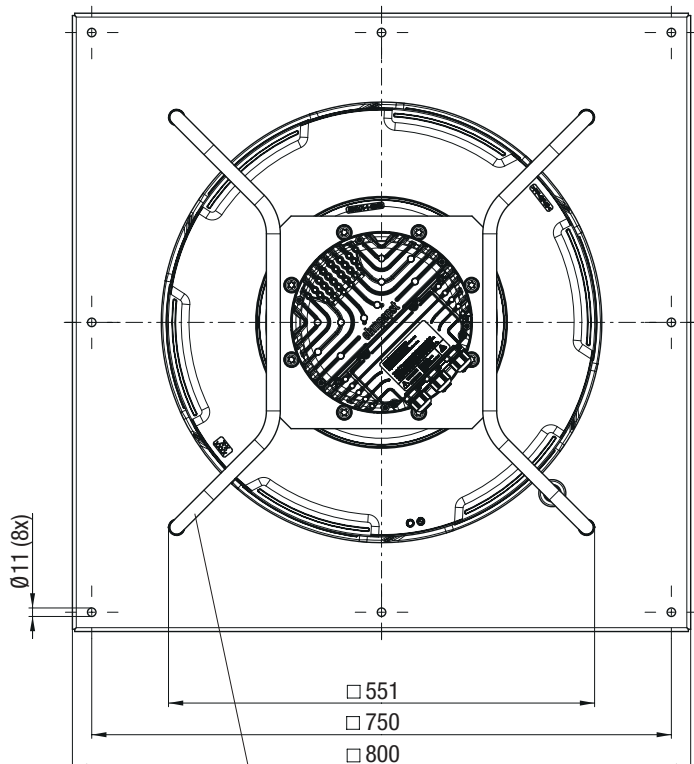
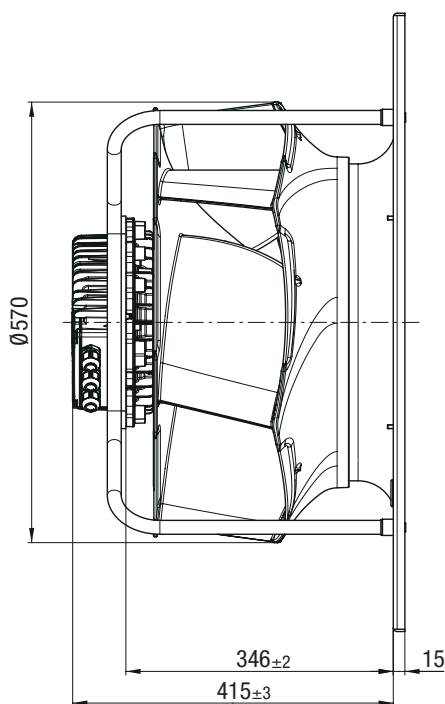

Note installed position! Install support struts as illustrated

EC centrifugal fans – RadiCal

backward curved, Ø 560 (with Aktive-PFC)



R3G 560-RB27-C1 (Centrifugal fan)



Accessory part: Inlet ring 54482-2-4013
Not included in scope of delivery
Dimensions: see "Accessories" chapter

Screw-in depth max. 20 mm

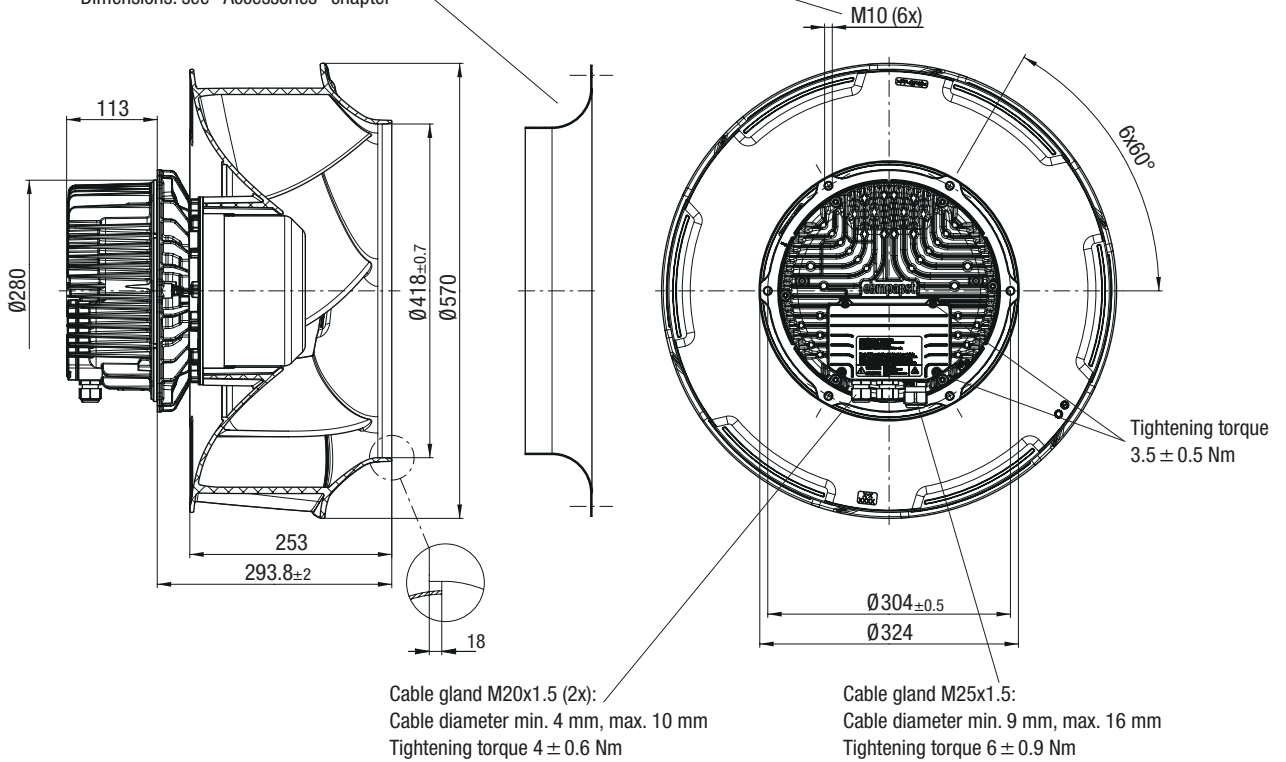

K3G 560-RB27-C1 (Centrifugal module with support bracket)



Attachment for FlowGrid

4x90°

Ø9 (4x)

40°

Inlet ring with pressure tap

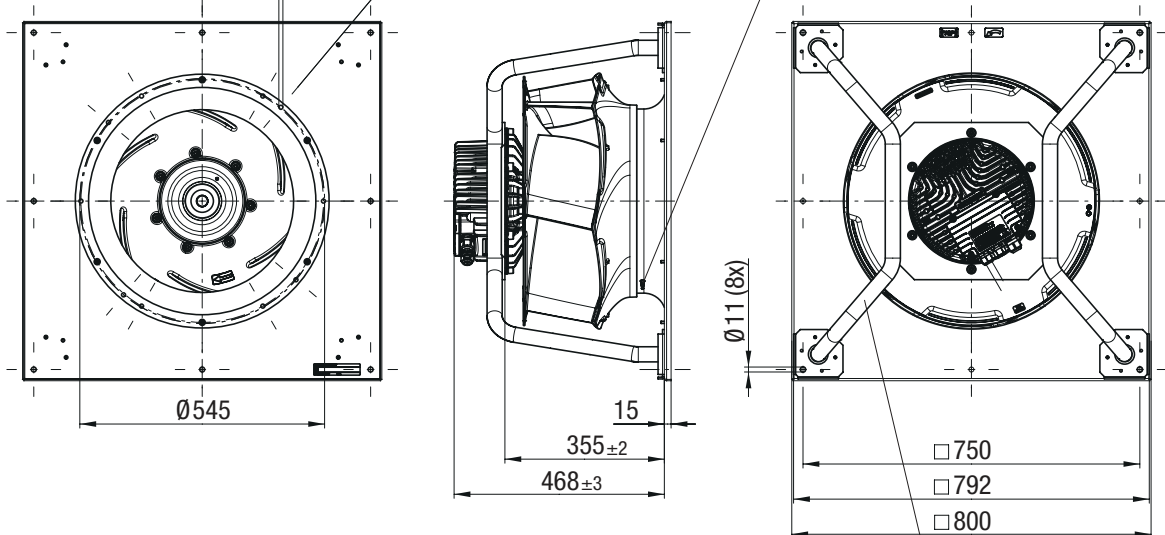

Note installed position! Install support struts as illustrated

EC centrifugal fans – RadiCal

backward curved, Ø 560



R3G 560-RA24-03 (Centrifugal fan)

Accessory part: Inlet ring 54482-2-4013
Not included in scope of delivery
Dimensions: see "Accessories" chapter

Screw-in depth max. 20 mm

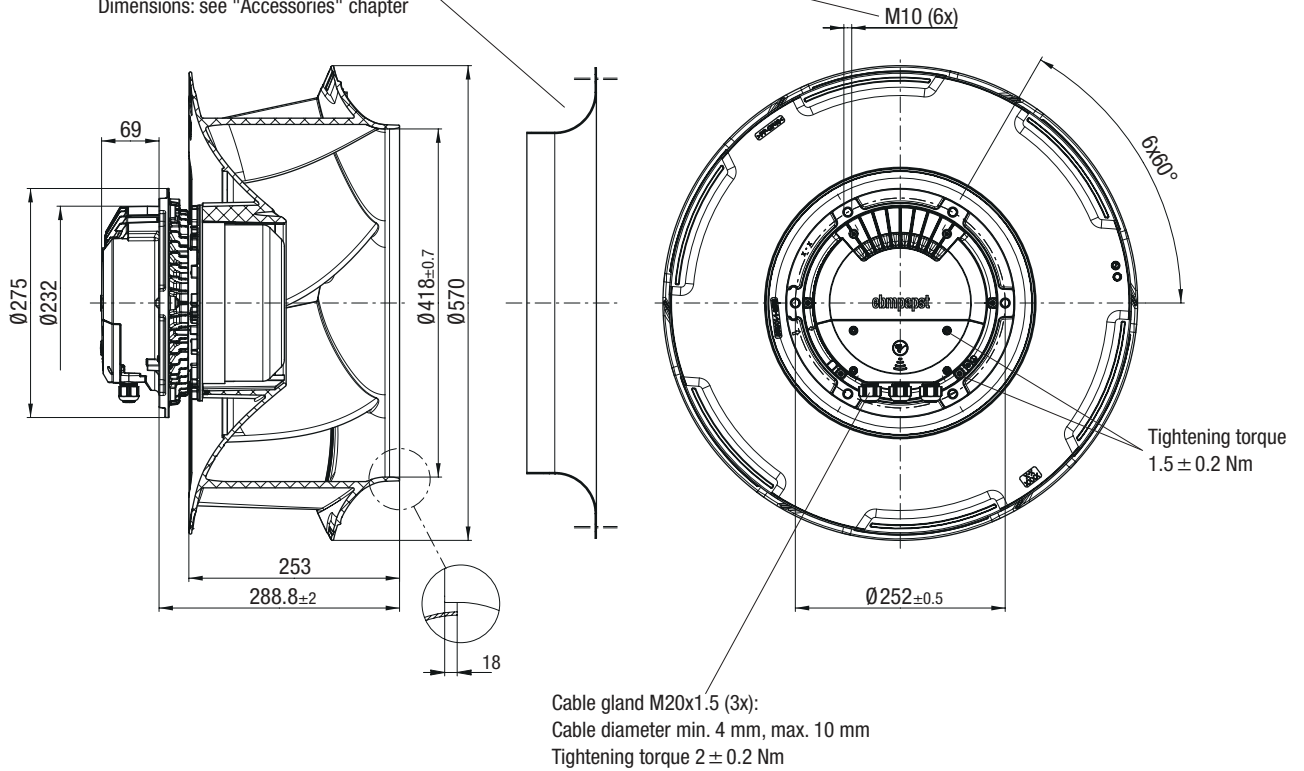

K3G 560-RA24-03 (Centrifugal module with support bracket)

Attachment for FlowGrid

Note installed position! Install support struts as illustrated

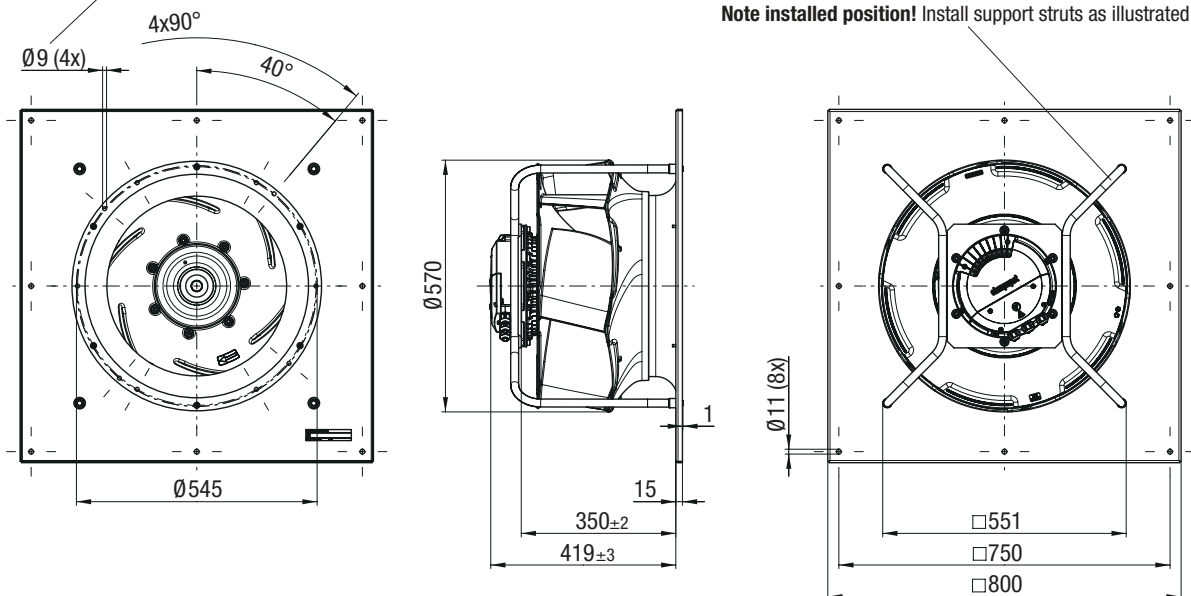
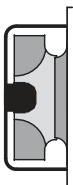

Tender specifications

Fan size 133 to 560

Direct-drive, single inlet centrifugal fans with backward-curved one-piece impellers made of high-tech composite material, based on a GreenTech EC external rotor motor with integrated control electronics.

Impeller, sizes 133 to 560 mm, made of high-tech composite material. This permits high circumferential speeds and thus a high power density suitable for a wide range of applications.

Motor impeller statically and dynamically balanced on two planes to balancing grade G 6.3 in accordance with DIN ISO 1940. GreenTech EC external rotor motor surpasses efficiency class IE4, magnets with no rare earths, maintenance-free ball bearings with long-term lubrication, theoretical nominal service life of at least 40,000 hours of operation.

Soft start, integrated current limitation, extended voltage input 1~200-277 V, 50/60 or 3~380-480 V, 50/60 Hz. The fan can be used with all standard power supply networks with unaltered air performance.

Integrated control electronics, low-noise commutation logic; 100% open-loop speed control; all fans have an optional RS485/MODBUS RTU interface, no shielded cables are required for connection.

All 1~ types feature integrated active PFC (Power Factor Correction) to reduce disturbing harmonic content.

Terminal box made of aluminum/plastic with easily accessible connection area, environment-resistant cable glands, or with brought-out cables.

Version for wall mounting:

Sizes 133 to 560, designed as ready-to-install support bracket intended for wall mounting. With sizes 133 to 250 the support structure is made of plastic, as of size 250 it is a black-coated, welded structure made of bent round steel bar with mounting plate and inlet ring made of sendzimir galvanized sheet steel. Installation position with horizontal motor shaft and vertical motor shaft with rotor on bottom. Vertical installation position with rotor on top on request.

Any work required for isolation from structure-borne noise is to be performed by the customer.

The fan satisfies the applicable EMC guidelines and requirements with regard to harmonic effects (see applicable data sheet for specific figures).

Documentation and marking in accordance with the applicable EU directives.

Reliable performance data, air performance measurements taken on an intake-side chamber test rig in accordance with ISO 5801 and DIN 24163. Noise measurements taken in an anechoic room in accordance with DIN EN ISO 3745.

Protective devices integrated in the motor:

- Alarm relay with floating contacts (250 V AC/2 A, $\cos \varphi = 1$)
- Locked-rotor protection
- Phase failure detection
- Soft start of motors
- Line undervoltage detection
- Thermal overload protection for electronics and motor
- Short circuit protection

Optional:

- Other and specific requirements on request

Technical data:

| | | | |
|-------------------------------|-------------------------|---|--|
| Fan type | | = | _____ - _____ - _____ |
| Air flow | qV | = | _____ m ³ /h, cfm |
| Stat. pressure increase | pfs | = | _____ Pa, in wg |
| Stat. overall efficiency | η_{es} | = | _____ % |
| Operating speed | n | = | _____ rpm |
| Motor type | | = | EC motor |
| Type of control | | = | 0-100 % speed control |
| Motor efficiency class | | = | IE4 (equivalent or better) |
| Total power input | Ped | = | _____ kW |
| Specific fan power | SFP | = | _____ kW/(m ³ /s) |
| Nominal voltage range | U _N | = | _____ V |
| Line frequency | f | = | 50 / 60 Hz |
| Nominal current | I _N | = | _____ A |
| Degree of protection | | = | IP54 |
| Sound power level | L _{WA} (A, in) | = | _____ / L _{WA} (A, out) = _____ dB(A) |
| Sound pressure level (at 1 m) | L _{pA} (A, in) | = | _____ / L _{pA} (A, out) = _____ dB(A) |
| Perm. ambient temperature | T | = | _____ to _____ °C |
| Weight of fan | m | = | _____ kg |



EC centrifugal fans - RadiCal
Support basket
Sizes 133 - 250



EC centrifugal fans - RadiCal
With housing
Sizes 190 / 225



EC centrifugal fans - RadiCal
Support bracket
Sizes 250 - 560

See data sheet for dimensions and connections.



Accessories



FlowGrid air inlet grill

Efficient noise reduction

ebm-papst fans are not measured on our own advanced test stands just for their air performance alone. The acoustic behavior of the fans is also examined and the measurement results are included in the technical documentation.

Please note that the measurements are taken under ideal conditions with undisturbed inflow and outflow. If the fans are subsequently installed and used in devices with rather tight spaces, it is to be expected that the noise data provided in the documentation will not be applicable.

In order to minimize the negative impact of the installation situation, ebm-papst offers the FlowGrid air-inlet guard shown here. It is installed on the intake side of the fan and effectively reduces the noise generated by the fan. Particularly annoying, low-frequency noises are reduced efficiently. The level of noise reduction is dependent on the installation situation, which is why no generally applicable data is possible here.



FlowGrid air inlet grill

Dimensions (mm)

| Part number | Fan size | ØB | ØC | ØE | S | H | N* | |
|--------------|--------------------|-----|---------|-----|-----|----|------------|--|
| 00190-2-2957 | 175, 190 | 170 | 155-160 | 4,5 | 2,0 | 30 | 2 ± 0,5 Nm | (FlowGrid is completely closed / Guard grill function) |
| 00250-2-2957 | 220, 225, 250 | 205 | 192-194 | 4,5 | 2,0 | 38 | 2 ± 0,5 Nm | (FlowGrid is completely closed / Guard grill function) |
| 20280-2-2957 | 220, 225, 250, 280 | 280 | 245-261 | 4,5 | 3,5 | 40 | 2 ± 0,5 Nm | |
| 25310-2-2957 | 310 | 315 | 288-292 | 5,5 | 3,5 | 49 | 2 ± 0,5 Nm | |
| 00400-2-2957 | 355, 400 | 370 | 334-346 | 4,5 | 3,5 | 56 | 2 ± 0,5 Nm | |
| 35505-2-2957 | 450, 500 | 470 | 440 | 9,0 | 3,5 | 71 | 10 ± 2 Nm | |
| 00630-2-2957 | 560 | 580 | 545 | 10 | 3,0 | 90 | 10 ± 2 Nm | |

Subject to change

* Recommended tightening torque for fastening screws

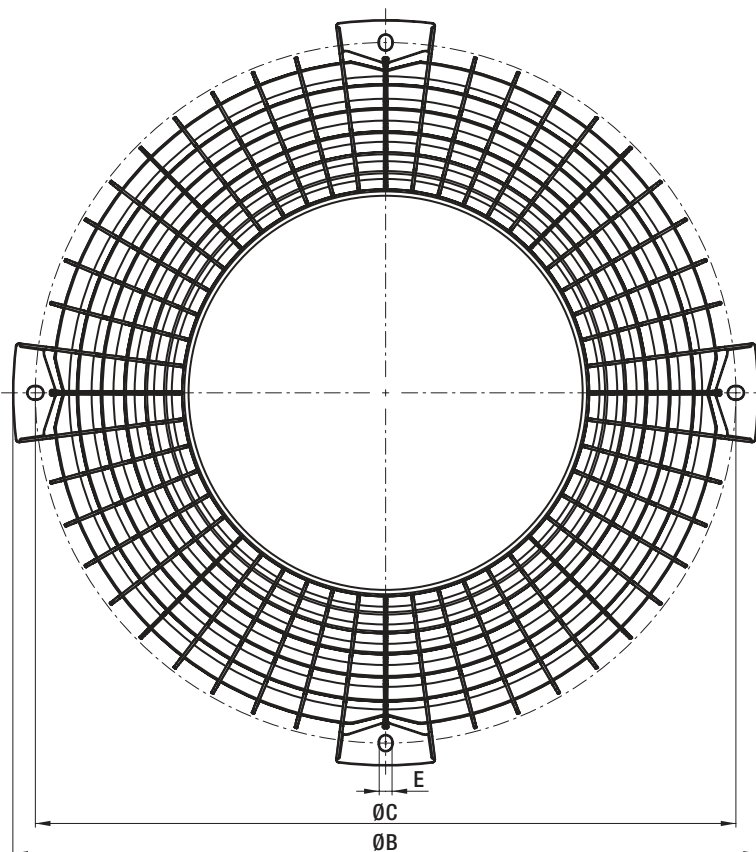

Would you like to find out more?

If you need an installation guide or more information about the dimensions, go to:

www.ebmpapst.com/flowgrid-manual

or scan the QR code below:



Intake finger guard

Wire mesh finger guard

– **Material:** Steel wire, phosphated, painted pebble gray (RAL 7032)

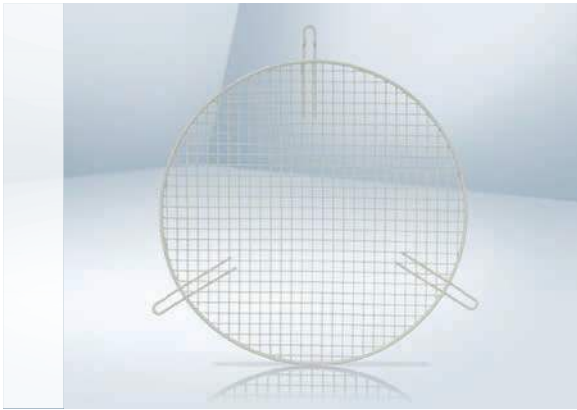

Intake finger guard for backwards-curved centrifugal fans (according to EN ISO 13857)

| Part number | Fan size | Version | a | b | d | e | Strut division | Dimensions (mm) |
|--------------|----------|---------|-----|-----|-----|-----|----------------|-----------------|
| 79280-2-4039 | 250, 280 | 1 | 280 | 4,5 | 227 | 2,8 | 4 x 90° | |
| 79310-2-4039 | 310 | 1 | 325 | 4,5 | 271 | 2,8 | 4 x 90° | |
| 79355-2-4039 | 355 | 1 | 345 | 4,5 | 308 | 2,8 | 4 x 90° | |
| 79400-2-4039 | 400 | 2 | 390 | 8,5 | 343 | 2,8 | 3 x 120° | |
| 79500-2-4039 | 450, 500 | 2 | 445 | 8,5 | 417 | 2,8 | 3 x 120° | |
| 79560-2-4039 | 560 | 2 | 490 | 8,5 | 466 | 2,8 | 3 x 120° | |

Subject to change

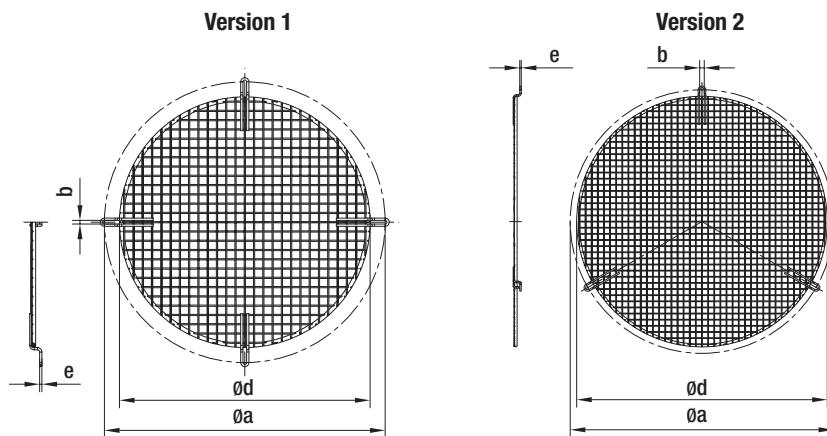

Guard grill for suction side for compact centrifugal modules

| Part number | Fan size | a | b | Dimensions (mm) |
|--------------|----------|------|-----|-----------------|
| 13351-2-2929 | 133 | 94,1 | 7,7 | |
| 19051-2-2929 | 175, 190 | 133 | 9,0 | |
| 22051-2-2929 | 220 | 166 | 8,7 | |
| 22551-2-2929 | 225 | 158 | 8,7 | |
| 25051-2-2929 | 250 | 177 | 9,7 | |

Subject to change

– **Material:** Plastic, fibreglass-reinforced

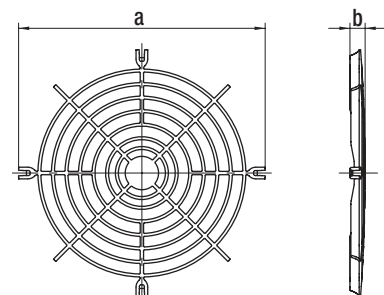

Inlet rings

With / without measuring device

- **Material:** Galvanized sheet steel,
Fan size 450 / 500: Plastic



Inlet rings with / without measuring device to determine the air flow for backwards-curved centrifugal fans

| Part number | Fan size | Dimensions / drawing |
|---|-----------|---|
| 09566-2-4013⁽¹⁾ (for centrifugal fans with M3G 055) | 133 | See Page 137 (Pressure extraction by centrifugal modules with M3G 055 see Page 139) |
| 09576-2-4013⁽¹⁾ (for centrifugal fans with M3G 055) | 175 / 190 | See Page 137 (Pressure extraction by centrifugal modules with M3G 055 see Page 139) |
| 09609-2-4013⁽¹⁾ (for centrifugal fans with M3G 055) | 220 | See Page 137 (Pressure extraction by centrifugal modules with M3G 055 see Page 139) |
| 96358-2-4013⁽¹⁾ (for centrifugal fans with M3G 055) | 225 | See Page 137 (Pressure extraction by centrifugal modules with M3G 055 see Page 139) |
| 96359-2-4013⁽¹⁾ (for centrifugal fans with M3G 055) | 250 | See Page 137 (Pressure extraction by centrifugal modules with M3G 055 see Page 139) |
| 96359-2-4013⁽¹⁾ / 96416-2-4013⁽²⁾ / 96400-2-4013⁽³⁾ | 250 | See Page 137 |
| 28000-2-4013⁽¹⁾ / 28004-2-4013⁽²⁾ / 28003-2-4013⁽³⁾ | 280 | See Page 137 |
| 31000-2-4013⁽¹⁾ / 31002-2-4013⁽²⁾ / 31003-2-4013⁽³⁾ | 310 | See Page 138 |
| 35500-2-4013⁽¹⁾ / 35504-2-4013⁽²⁾ / 35503-2-4013⁽³⁾ | 355 | See Page 138 |
| 54476-2-4013⁽¹⁾ / 54250-2-4013⁽²⁾ / 54501-2-4013⁽³⁾ | 400 | See Page 138 |
| 45901-2-2943⁽¹⁾ / 45915-2-2943⁽²⁾ / 45910-2-2943⁽³⁾ | 450 | See Page 138 |
| 50901-2-2943⁽¹⁾ / 50910-2-2943⁽²⁾ / 50920-2-2943⁽³⁾ | 500 | See Page 138 |
| 54482-2-4013⁽¹⁾ / 54495-2-4013⁽²⁾ / 54492-2-4013⁽³⁾ | 560 | See Page 139 |

Subject to change

⁽¹⁾ Without measuring device

⁽²⁾ With one pressure tap

⁽³⁾ With piezometer

(1) Without measuring device:

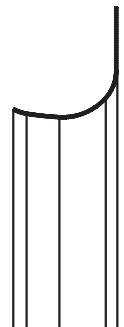

(2) With one pressure tap:

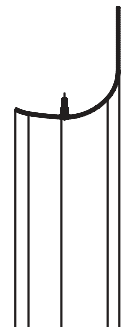

(3) With piezometer:

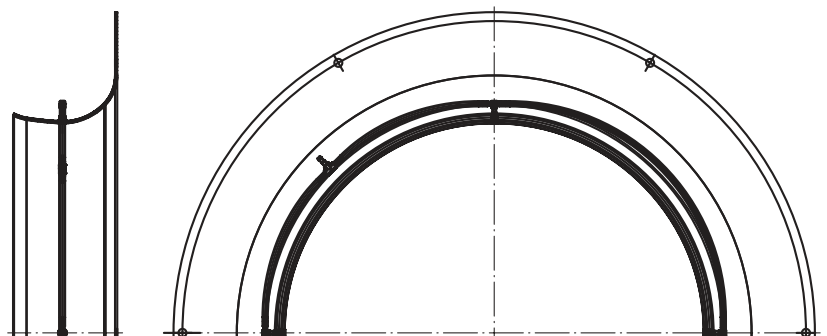

Inlet rings

Dimensioned drawings without measuring device

Fan size 133:

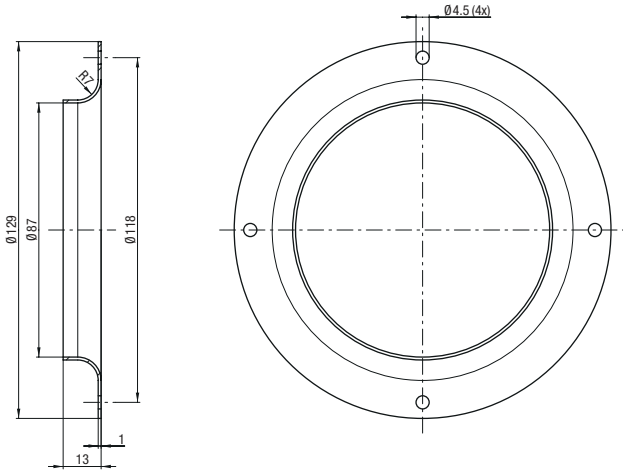

Fan size 175 / 190:

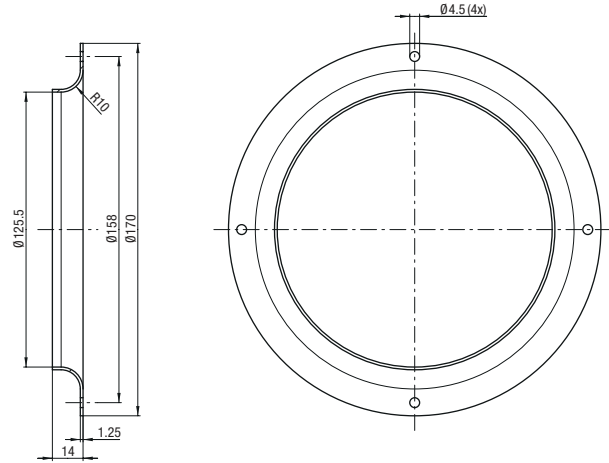

Fan size 220:

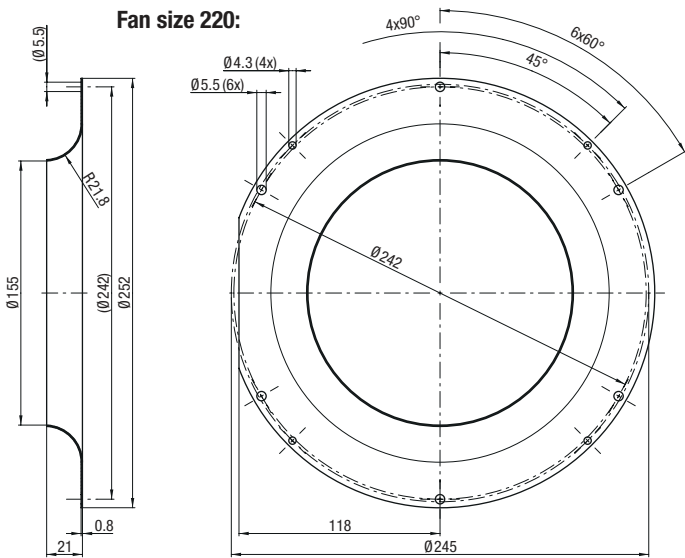

Fan size 225:

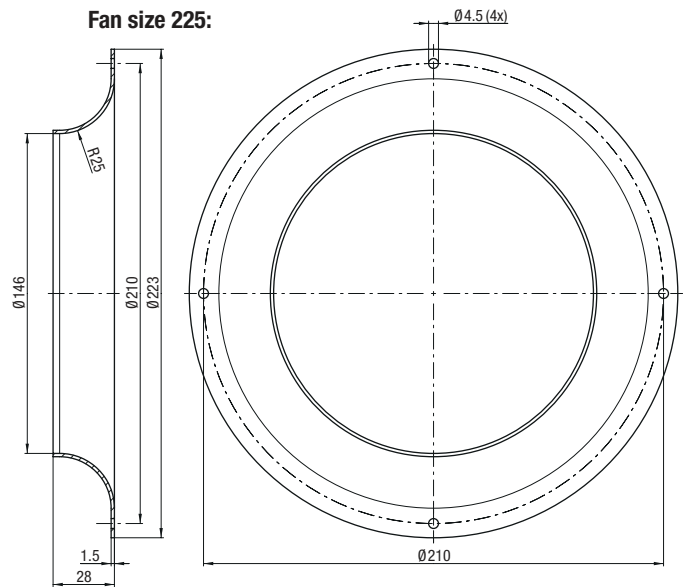

Fan size 250:

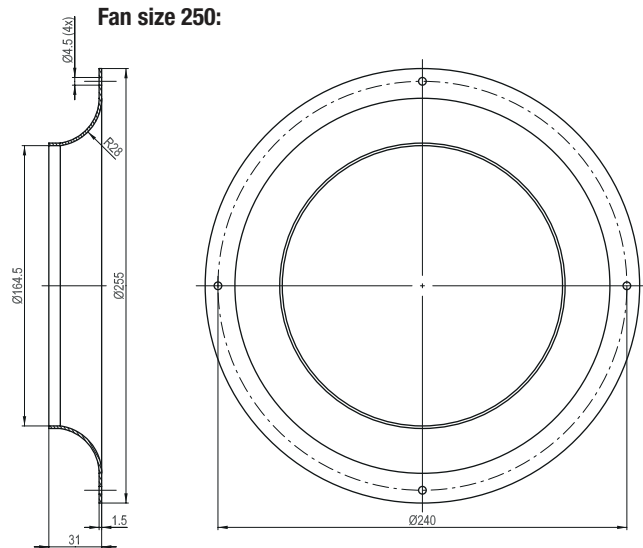

Fan size 280:

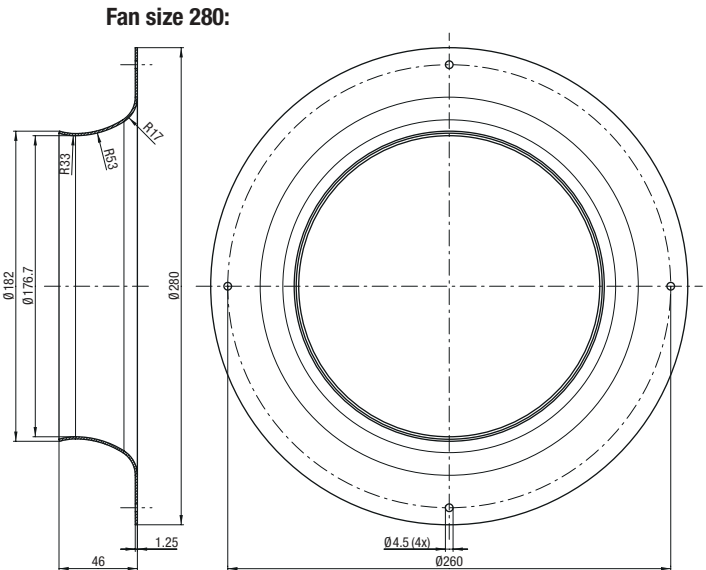

Inlet rings

Dimensioned drawings without measuring device

Fan size 310:

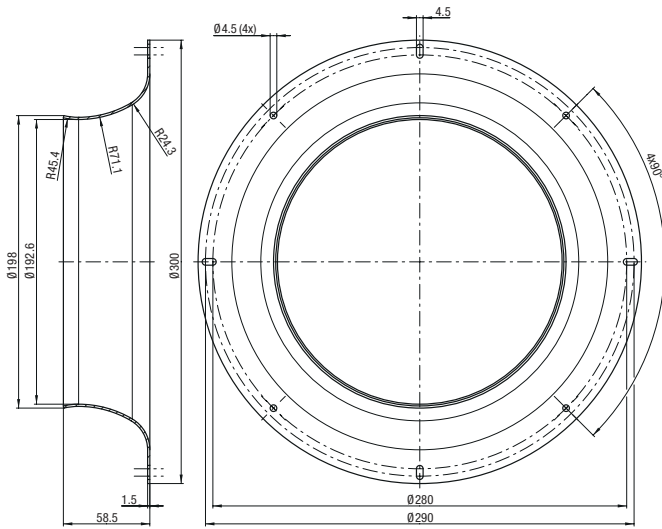

Fan size 355:

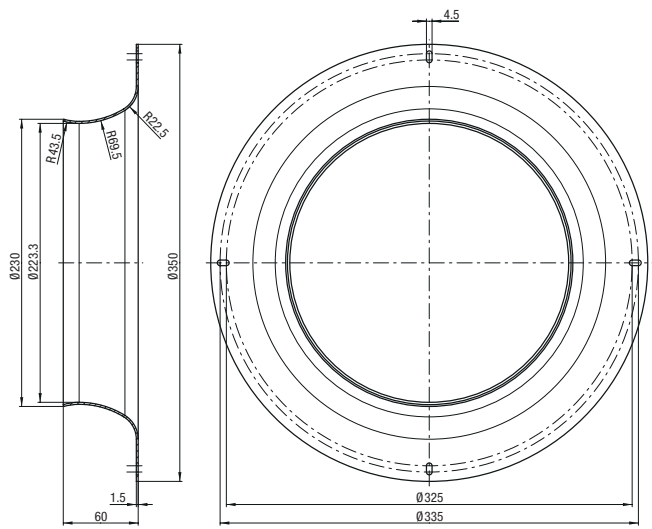

Fan size 400:

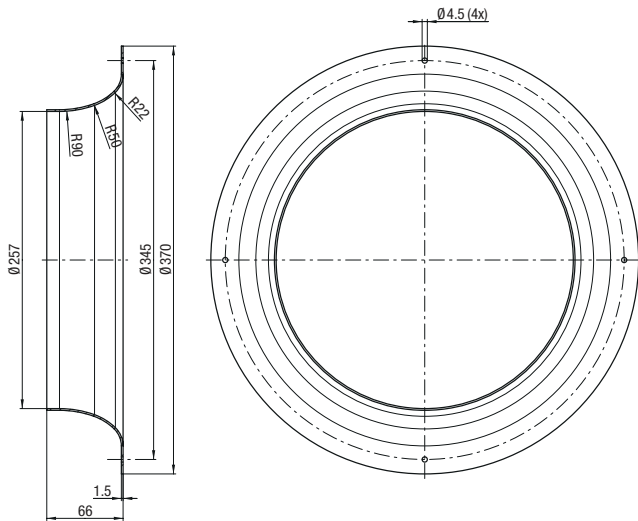

Fan size 450:

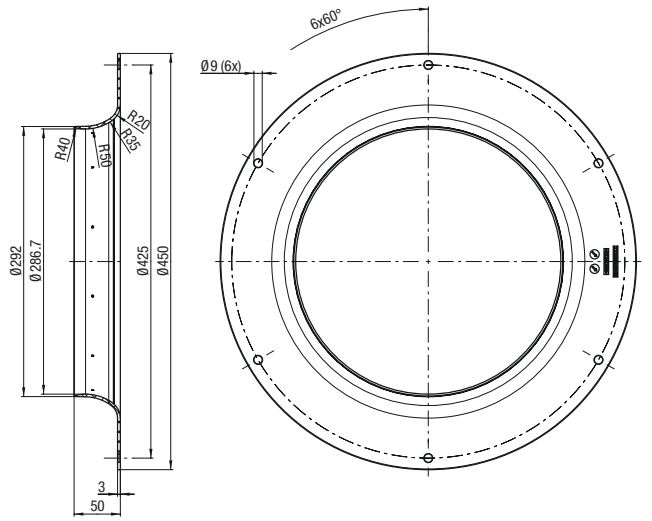

Fan size 500:

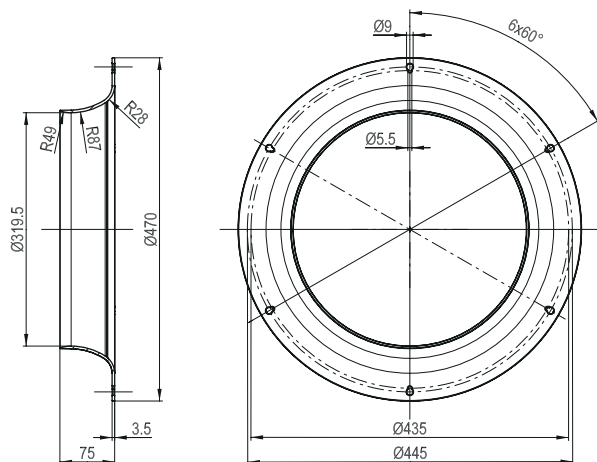

Inlet rings

Dimensioned drawings without measuring device

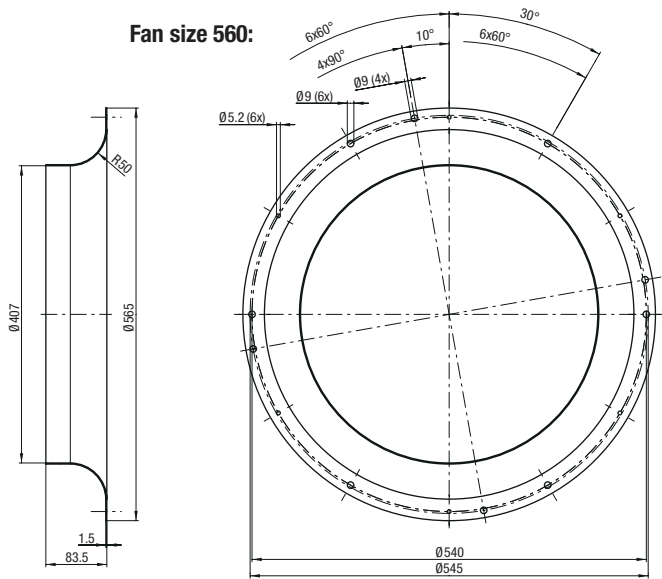

Pressure extraction

Centrifugal modules, fan size 133 - 250

Pressure extraction for centrifugal modules, fan size 133 - 250

| Part number | Component parts |
|--------------|-------------------------------------|
| 20000-2-2945 | Pressure transducer (A) |
| 43426-4-5154 | Closure cap for pressure transducer |
| 79600-2-5120 | T-tube connector (B) |
| 02636-7-7024 | Silicone tube (C) |

Subject to change

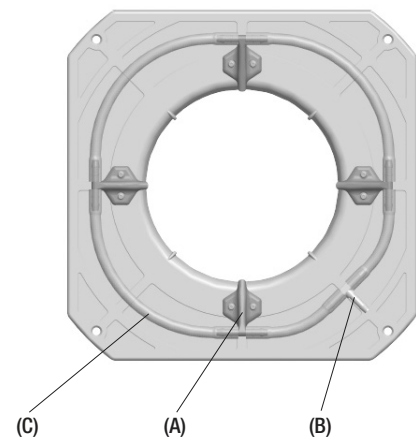

Air flow measurement

Air flow measurement:

The differential pressure method compares the static pressure upstream of the inlet ring with the static pressure in the inlet ring.

The air flow can be calculated from the differential pressure (between the static pressures) according to the following equation:

$$q_V = k \cdot \sqrt{\Delta p} \quad q_V \text{ in [m}^3/\text{h] und } \Delta p \text{ in [Pa]}$$

If the air flow is to be regulated to remain constant, the inlet pressure must be kept constant:

$$\Delta p = q_V^2 : k^2 \quad q_V \text{ in [m}^3/\text{h] und } \Delta p \text{ in [Pa]}$$

k takes into account the specific properties of the inlet ring.

The pressure is tapped at 1 (4) point(s) on the circumference of the inlet ring. The customer connection consists of a built-in T-shaped hose fitting. The hose fitting is suitable for pneumatic hoses with an inside diameter of 4 mm.

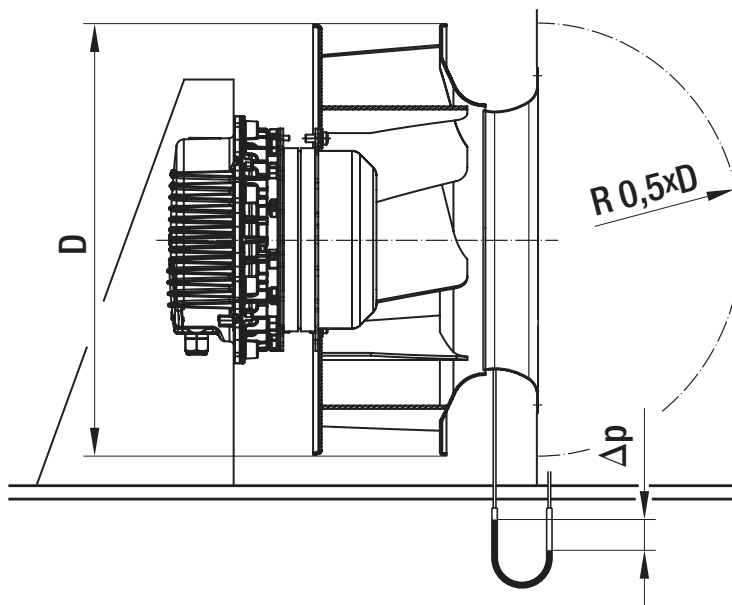

| k-factors: (for RadiCal inlet rings) | | | | | | | |
|--------------------------------------|-----|-----|-----|-----|-----|-------|-----|
| Fan size | 133 | 175 | 190 | 220 | 225 | 250 | 280 |
| k-factor | 15 | 30 | 30 | 50 | 51 | 60/61 | 77 |
| Fan size | 310 | 355 | 400 | 450 | 500 | 560 | |
| k-factor | 93 | 128 | 180 | 190 | 260 | 405 | |



Connection diagrams

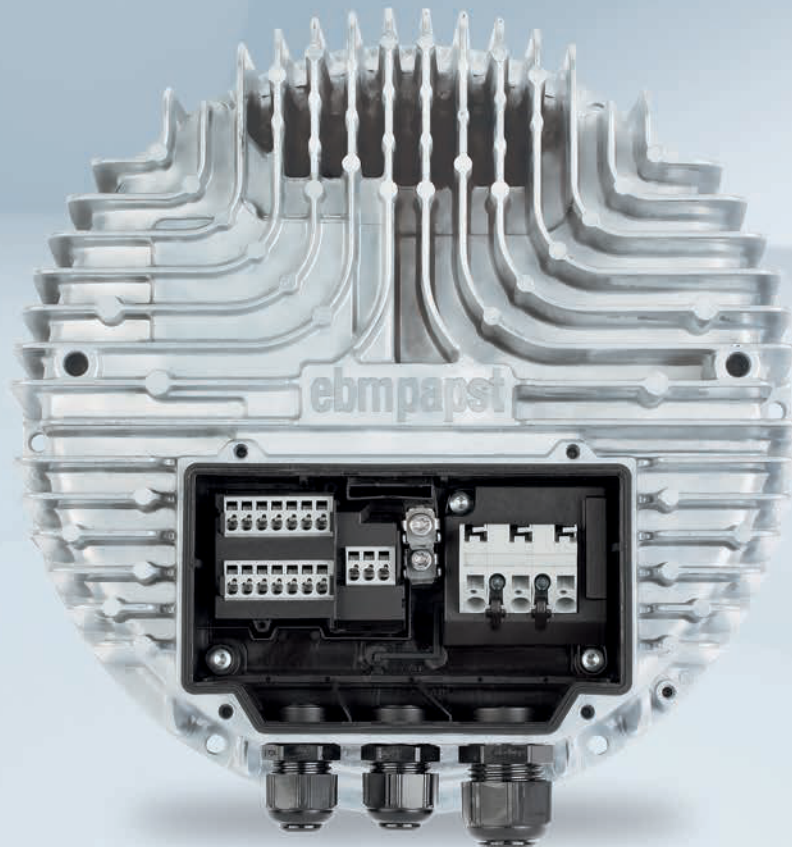

Connection diagram EC RC1)

Technical features (M3G 055 Speed-controlled):

- Control input 0-10 VDC / PWM
- Output 10 VDC max. 1,1 mA
- Tach output
- Thermal overload protection for electronics/motor
- Motor current limitation
- Locked-rotor protection
- Soft start
- Control interface with SELV potential safely disconnected from supply

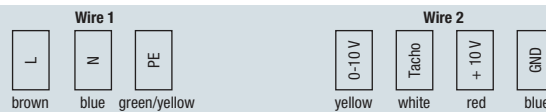

| Wire | Connection | Color | Assignment/function |
|------|-------------------|--------------|--|
| 1 | L | brown | Power supply, phase, voltage range see nameplate |
| 1 | N | blue | Power supply, neutral conductor, voltage range see nameplate |
| 1 | PE | green/yellow | Protective earth |
| 2 | 0-10 V / PWM | yellow | Control input 0-10 V or PWM, impedance 100 kΩ, SELV |
| 2 | Tacho | white | Tach output: Open Collector, 1 pulse per revolution, SELV |
| 2 | +10 V/max. 1.1 mA | red | Voltage output, SELV |
| 2 | GND | blue | Reference ground for control interface |

Connection diagram EC RC2)

Technical features (M3G 045 / M3G 055 with 2 Speed stages):

- Speed adjustment input (230V)
- Thermal overload protection for electronics/motor
- Motor current limitation
- Locked-rotor protection
- Soft start

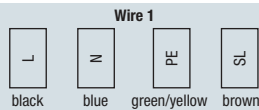

| Wire | Connection | Color | Assignment/function |
|------|------------|--------------|---|
| 1 | L | black | Power supply, phase, voltage range see nameplate |
| 1 | N | blue | Power supply, neutral conductor, voltage range see nameplate |
| 1 | PE | green/yellow | Protective earth |
| 1 | SL | brown | Speed selection: switch open = speed 1; switch closed = speed 2 |

Connection diagram EC RC3)

Technical features (M3G 045 / M3G 055 Speed-controlled; M3G 074):

- Control input 0-10 VDC / PWM
- Output 10 VDC max. 1,1 mA
- Tach output
- Thermal overload protection for electronics/motor
- Motor current limitation
- Locked-rotor protection
- Soft start
- Control interface with SELV potential safely disconnected from supply

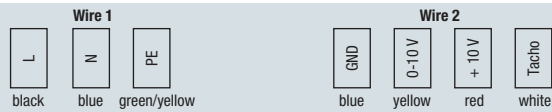

| Wire | Connection | Color | Assignment/function |
|------|-------------------|--------------|--|
| 1 | L | black | Power supply, phase, voltage range see nameplate |
| 1 | N | blue | Power supply, neutral conductor, voltage range see nameplate |
| 1 | PE | green/yellow | Protective earth |
| 2 | GND | blue | Reference ground for control interface |
| 2 | 0-10 V / PWM | yellow | Control input 0-10 V or PWM, impedance 100 k Ω , SELV |
| 2 | +10 V/max. 1.1 mA | red | Voltage output, SELV |
| 2 | Tacho | white | Tach output: Open Collector, 1 pulse per revolution, SELV |

Connection diagram EC RC4)

Technical features:

- PFC (active)
- Integrated PI controller
- Control input 0-10 VDC / PWM
- Output 10 VDC max. 10 mA
- Operation and fault indicator
- RS485 MODBUS-RTU
- Motor current limitation, Alarm relay
- Undervoltage/phase failure detection
- Thermal overload protection for electronics/motor
- Locked-rotor protection, Soft start
- Control interface with SELV potential safely disconnected from supply

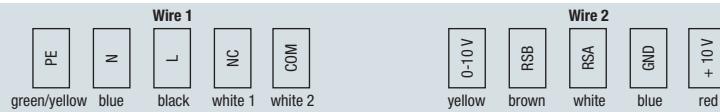

| Wire | Connection | Color | Assignment/function |
|------|------------------|--------------|--|
| 1 | PE | green/yellow | Protective earth |
| 1 | N | blue | Power supply, neutral conductor, voltage range see nameplate |
| 1 | L | black | Power supply, phase, voltage range see nameplate |
| 1 | NC | white 1 | Status relay, floating status contact, break for failure |
| 1 | COM | white 2 | Status relay, floating status contact, common connection, contact rating 250 VAC / 2 A (AC1) min. 10 mA, basic insulation on supply side and reinforced insulation on control interface side |
| 2 | 0-10 V / PWM | yellow | Control input 0-10 V or PWM, impedance 100 kΩ, adjustable curve, SELV |
| 2 | RSB | brown | RS-485 interface for MODBUS RSB, SELV |
| 2 | RSA | white | RS-485 interface for MODBUS RSA, SELV |
| 2 | GND | blue | Reference ground for control interface, SELV |
| 2 | +10 V/max. 10 mA | red | Voltage output 10 VDC, power supply for external devices (e.g. potentiometers), SELV |

Connection diagram EC RC5)

Technical features:

- PFC (passive)
- Integrated PI controller
- Control input 0-10 VDC / PWM
- Output 10 VDC max. 10 mA
- Operation and fault indicator
- RS485 MODBUS-RTU
- Motor current limitation, Alarm relay
- Undervoltage/phase failure detection
- Thermal overload protection for electronics/motor
- Locked-rotor protection, Soft start
- Control interface with SELV potential safely disconnected from supply

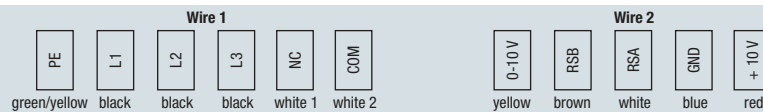

| Wire | Connection | Color | Assignment/function |
|------|------------|--------------|--|
| 1 | PE | green/yellow | Protective earth |
| 1 | L1, L2, L3 | black | Power supply, phase, voltage range see nameplate |
| 1 | NC | white 1 | Status relay, floating status contact, break for failure, contact rating 250 VAC / 2 A (AC1) min. 10 mA, basic insulation on supply side and reinforced insulation on control interface side |
| 1 | COM | white 2 | Status relay, floating status contact, common connection, contact rating 250 VAC / 2 A (AC1) min. 10 mA, basic insulation on supply side and reinforced insulation on control interface side |
| 2 | 0-10 V | yellow | Analog input (set value), 0-10 V, impedance 100 kΩ, adjustable curve, SELV |
| 2 | RSB | brown | RS-485 interface for MODBUS RSB, SELV |
| 2 | RSA | white | RS-485 interface for MODBUS RSA, SELV |
| 2 | GND | blue | Reference ground for control interface, SELV |
| 2 | + 10 V | red | Fixed voltage output 10 VDC, +10 V +/- 3%, max. 10 mA, short-circuit-proof, power supply for external devices (e.g. potentiometers), SELV |

Connection diagram EC RC6)

Technical features:

- PFC (passive)
- Integrated PI controller
- Control input 0-10 VDC / PWM
- External enable input
- External 24 V input (parameterization)
- Output 10 VDC max. 10 mA
- Operation and fault indicator
- RS485 MODBUS-RTU
- Motor current limitation
- Alarm relay
- Undervoltage/phase failure detection
- Thermal overload protection for electronics/motor
- Reverse polarity and locked-rotor protection
- Soft start
- Control interface with SELV potential safely disconnected from supply

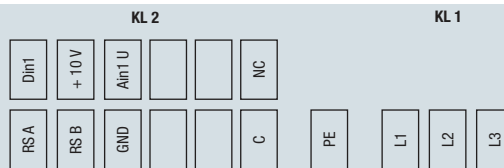

| Terminal | Connection | Assignment/function |
|----------|--|--|
| KL1 | L1 | Power supply, phase, voltage range see nameplate |
| | L2 | Power supply, phase, voltage range see nameplate |
| | L3 | Power supply, phase, voltage range see nameplate |
| PE | PE | Protective earth |
| KL2 | RSA | RS-485 interface for MODBUS RSA, SELV |
| | RSB | RS-485 interface for MODBUS RSB, SELV |
| | GND | Reference ground for control interface, SELV |
| | C | Status relay, floating status contact, changeover contact, common connection; contact rating 250 VAC / 2 A (AC1), min. 10 mA |
| | Din1 | Digital input 1: Enable electronics; Enable: Pin open or applied voltage 5 to 50 VDC; Disable: Bridge to GND or applied voltage < 1 VDC; Reset function: Triggering of software reset after a level change to < 1V, SELV |
| | + 10 V | Fixed voltage output 10 VDC; +10 V \pm 3 %; max. 10 mA; short-circuit-proof; Power supply for external devices (e.g. potentiometers), SELV |
| | Ain1 U | Analog input 1; set value; 0-10 V, Ri=100 k Ω ; adjustable curve, SELV |
| NC | Status relay, floating status contact, break for failure | |

Connection diagram EC RC7)

Technical features:

- PFC (active)
- Integrated PI controller
- Control input 0-10 VDC / PWM
- Input for sensor 0-10 V or 4-20 mA
- External 24 V input (parameterization)
- External enable input
- Output for Slave 0-10 V max. 3 mA
- Output 20 VDC ($\pm 20\%$) max. 50 mA
- Output 10 VDC ($+10\%$) max. 10 mA
- Tach output
- RS485 MODBUS-RTU
- Alarm relay
- Undervoltage/phase failure detection
- Motor current limitation
- Power limiter
- Thermal overload protection for electronics/motor
- Reverse polarity and locked-rotor protection
- Soft start
- Control interface with SELV potential safely disconnected from supply

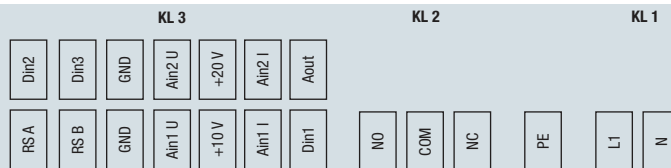

| Terminal | Connection | Assignment/function |
|----------|------------------|--|
| KL1 | N | Power supply, neutral conductor, voltage range see nameplate |
| | L1 | Power supply, phase, voltage range see nameplate |
| PE | PE | Protective earth |
| KL2 | NC | Status relay, floating status contact, option 1: break for failure, option 2: break for run monitoring error message |
| | COM | Status relay, floating status contact, common connection, contact rating 250 VAC / 2 A (AC1) min. 10 mA, reinforced insulation on supply side and on control interface side |
| | NO | Status relay, floating status contact, option 1: make for failure, option 2: make for run monitoring error message |
| KL3 | DIN1 | Digital input 1: Enable electronics, Enable: Pin open or applied voltage 5...50 VDC, Disable: Bridge to GND or applied voltage < 1,0 VDC, Reset function: Triggering of software reset after level change to < 1,0 V |
| | Ain1 I | Analog input 1; set value; 4-20 mA; Ri=100 Ω; adjustable curve, only for use as alternative to input Ain1 U, SELV |
| | +10 V/max. 10 mA | Voltage output 10 VDC, power supply for external devices (e.g. potentiometers), SELV |
| | Ain1 U | Analog input 1; set value; 0-10 V, Ri=100 kΩ; adjustable curve, only for use as alternative to input Ain1 I, SELV |
| | GND | Reference ground for control interface |
| | RSB | RS-485 interface for MODBUS RSB |
| | RSA | RS-485 interface for MODBUS RSA |
| | Aout | Analog output 0-10 V; max. 5 mA; output of current motor modulation level / current motor speed; adjustable curve; SELV |
| | Ain2 I | Analog input 2; Measured value; 4-20 mA; Ri=100 Ω; adjustable curve, only for use as alternative to input Ain2 U, SELV |

| Terminal | Connection | Assignment/function |
|----------|------------|--|
| KL3 | + 20 V | Fixed voltage output 20 VDC, + 20 V +25/-10%, max. 50 mA, short-circuit-proof, power supply for external devices (e.g. sensors) |
| | Ain2 U | Analog input 2; Measured value; 0-10 V; Ri=100 kΩ; adjustable curve, only for use as alternative to input Ain2 I, SELV |
| | GND | Reference ground for control interface |
| | Din3 | Digital input 3: Direction of action of integrated controller, according to EEPROM setting, the direction of action of the integrated controller can be selected as normal/inverse via bus or digital input Normal: Pin open or applied voltage 5-50 VDC; Inverse: Bridge to GND or applied voltage < 0,8 VDC |
| | Din2 | Digital input 2: Switching parameter sets 1/2; according to EEPROM setting, the valid or used parameter set can be selected via bus or via digital input Din2. Parameter set 1: Pin open or applied voltage 5-50 VDC; Parameter set 2: Bridge to GND or applied voltage < 0,8 VDC |

Connection diagram EC RC8)

Technical features:

- Control input 0-10 VDC / PWM
- Output 10 VDC max. 10 mA
- Motor current limitation
- Power limiter
- Overvoltage detection
- Soft start
- Thermal overload protection for electronics/motor
- Control interface with SELV potential safely disconnected from supply

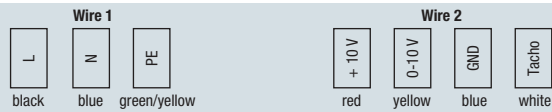

| Wire | Connection | Color | Assignment/function |
|------|--------------|--------------|--|
| 1 | L | black | Power supply, phase, voltage range see nameplate |
| 1 | N | blue | Power supply, neutral conductor, voltage range see nameplate |
| 1 | PE | green/yellow | Protective earth |
| 2 | + 10 V | red | Fixed voltage output 10 VDC +/- 3 %, I _{max} 10 mA, short-circuit-proof, power supply for external devices (e.g. potentiometer), SELV |
| 2 | 0-10 V / PWM | yellow | Control input 0-10 V or PWM, impedance 100 kΩ, SELV |
| 2 | GND | blue | Reference ground for control interface, SELV |
| 2 | Tacho | white | Tach output: Open Collector, 1 pulse per revolution, SELV |

Connection diagram EC RC9)

Technical features:

- Configurable inputs/outputs (I/O)
- RFID - ISO 15693 compatible
- Operation and alarm display with LED
- Integrated PI controller
- Locked-rotor protection
- Motor current limitation / Alarm relay
- Soft start
- Voltage output 3.3-24 VDC, Pmax = 800 mW
- RS 485 MODBUS-RTU / MODBUS V6
- Thermal overload protection for electronics/motor
- Undervoltage/phase failure detection
- Control interface with SELV potential safely disconnected from supply
- External 15-50 VDC input (parameterization)

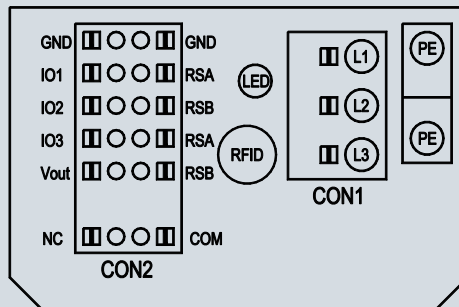

| Terminal | Connection | Assignment/function |
|----------|------------|---|
| CON1 | L1, L2, L3 | Power supply, phase, voltage range see nameplate, protection class 1 |
| PE | PE | Protective earth |
| CON2 | RSA | RS-485 interface for MODBUS RSA, SELV |
| | RSB | RS-485 interface for MODBUS RSB, SELV |
| | GND | Reference ground for control interface, SELV |
| | IO1 | IN2: Digital input - positive logic (factory setting: Enable) function parameterizable, SELV - normal: Pin open or applied voltage < 1.5 VDC - inverse: applied voltage 3.5-50 VDC |
| | IO2 | IN1: Analog input 0-10 V 0-10 V, Ri=100 K, parameterizable as set value or measured value (factory setting: set value) characteristic curve parameterizable, SELV |
| | IO3 | OUT1: Analog output 0-10 V 0-10 V, max 5 mA, function parameterizable (factory setting: modulation level) max output frequency 300 Hz, SELV |
| | V out | Voltage output 3,3-24 VDC +/- 5 %, Pmax=800 mW, voltage parameterizable (factory setting: 10 VDC) short-circuitproof, supply for external devices, SELV alternatively: 15-50 VDC input for parameterization via Modbus without line voltage |
| | COM | Status relay, floating status contact, common connection, nominal voltage 250VAC; max 2A (AC1), min 10mA; reinforced insulation according to EN60335-1, EN61800-5-1, UL60730-1 |
| | NC | Status relay, floating status contact, break for failure |

Connection diagram EC RC10)

Technical features (M3G 055 Speed-controlled):

- Control input PWM
- Tach output
- Thermal overload protection for electronics/motor
- Motor current limitation
- Locked-rotor protection
- Soft start
- Control interface with SELV potential safely disconnected from supply

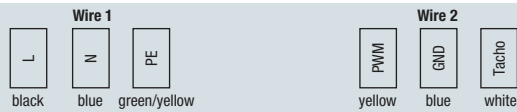

| Wire | Connection | Color | Assignment/function |
|------|------------|--------------|--|
| 1 | L | black | Power supply, phase, voltage range see nameplate |
| 1 | N | blue | Power supply, neutral conductor, voltage range see nameplate |
| 1 | PE | green/yellow | Protective earth |
| 2 | PWM | yellow | Control input PWM / 1-10 kHz, impedance 1 k Ω , I _{sink} = 5-10 mA, SELV |
| 2 | GND | blue | Reference ground for control interface, SELV |
| 2 | Tacho | white | Tach output: Open Collector, 1 pulse per revolution, SELV |

Connection diagram EC RC11)

Technical features:

- Integrated PI controller
- Power limiter
- Motor current limitation
- Locked-rotor protection, Soft start
- Operation and fault indicator
- RS485 MODBUS-RTU
- Undervoltage detection
- Thermal overload protection for electronics/motor
- Control interface with SELV potential safely disconnected from supply
- Auto addressing can be activated via BUS

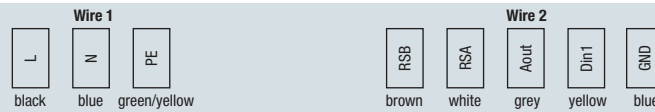

| Wire | Connection | Color | Assignment/function |
|------|------------|--------------|--|
| 1 | L | black | Power supply, phase, voltage range see nameplate |
| 1 | N | blue | Power supply, neutral conductor, voltage range see nameplate |
| 1 | PE | green/yellow | Protective earth |
| 2 | RSB | brown | RS-485 interface for MODBUS RSB, SELV |
| 2 | RSA | white | RS-485 interface for MODBUS RSA, SELV |
| 2 | Aout | grey | Auto addressing |
| 2 | Din1 | yellow | Auto addressing |
| 2 | GND | blue | Reference ground for control interface, SELV |

Connection diagram EC RC12)

Technical features (M3G 055 Sensor-controlled):

- Power limiter
- RS485 MODBUS-RTU
- Overvoltage detection
- Under voltage detection
- Thermal overload protection for electronics/motor
- Control interface with SELV potential safely disconnected from supply
- Motor current limitation
- Soft start

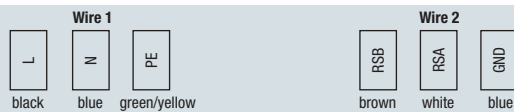

| Wire | Connection | Color | Assignment/function |
|------|------------|--------------|--|
| 1 | L | black | Power supply, phase, voltage range see nameplate |
| 1 | N | blue | Power supply, neutral conductor, voltage range see nameplate |
| 1 | PE | green/yellow | Protective earth |
| 2 | RSB | brown | RS-485 interface for MODBUS RSB, SELV |
| 2 | RSA | white | RS-485 interface for MODBUS RSA, SELV |
| 2 | GND | blue | Reference ground for control interface, SELV |

Connection diagram EC RC13)

Technical features (M1G 055 Speed-controlled):

- Tach output
- Control input PWM
- Power limiter
- Thermal overload protection for motor
- Control interface with SELV potential safely disconnected from supply
- Motor current limitation
- Soft start

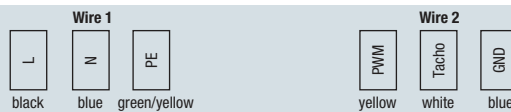

| Wire | Connection | Color | Assignment/function |
|------|------------|--------------|--|
| 1 | L | black | Power supply, phase, voltage range see nameplate |
| 1 | N | blue | Power supply, neutral conductor, voltage range see nameplate |
| 1 | PE | green/yellow | Protective earth |
| 2 | PWM | yellow | Control input PWM / 1-10 kHz, impedance 1 k Ω , Isink = 5-10 mA, SELV |
| 2 | Tacho | white | Tach output: Open Collector, 1 pulse per revolution, SELV |
| 2 | GND | blue | Reference ground for control interface, SELV |

Connection diagram EC RC14)

Technical features:

- PFC (active)
- Integrated PI controller
- Control input 0-10 VDC / PWM
- Input for sensor 0-10 V or 4-20 mA
- External 24 V input (parameterization)
- External enable input
- Output for Slave 0-10 V max. 3 mA
- Output 20 VDC ($\pm 20\%$) max. 50 mA
- Output 10 VDC ($+10\%$) max. 10 mA
- Soft start
- RS485 MODBUS-RTU
- Operation and fault indicator
- Undervoltage/phase failure detection
- Motor current limitation
- Power limiter
- Thermal overload protection for electronics/motor
- Reverse polarity and locked-rotor protection
- Control interface with SELV potential safely disconnected from supply

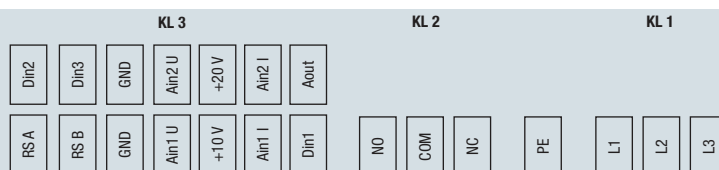

| Terminal | Connection | Assignment/function |
|----------|------------|--|
| KL1 | L1, L2, L3 | Power supply, phase, voltage range see nameplate |
| PE | PE | Protective earth |
| KL2 | NC | Status relay, floating status contact, break for failure |
| | COM | Status relay, floating status contact, common connection, contact rating 250 VAC / 2 A (AC1) min. 10 mA, reinforced insulation on supply side and on control interface side |
| | NO | Status relay, floating status contact, make for failure |
| KL3 | DIN1 | Digital input 1: Enable electronics, Enable: Pin open or applied voltage 5...50 VDC, Disable: Bridge to GND or applied voltage < 1 VDC, Reset function: Triggering of software reset after level change to < 1 V; SELV |
| | Ain1 I | Analog input 1; set value; 4-20 mA; Ri=100 Ω ; adjustable curve, only for use as alternative to input Ain1 U, SELV |
| | + 10 V | Fixed voltage output 10 VDC, + 10 V $\pm 3\%$ max. 10 mA, short-circuit-proof, Power supply for external devices (e.g. potentiometer); SELV |
| | Ain1 U | Analog input 1; set value; 0-10 V, Ri=100 k Ω ; adjustable curve, only for use as alternative to input Ain1 I, SELV |
| | GND | Reference ground for control interface; SELV |
| | RSB | RS-485 interface for MODBUS RSB; SELV |
| | RSA | RS-485 interface for MODBUS RSA; SELV |
| | Aout | Analog output 0-10 V; max. 5 mA; output of current motor modulation level / current motor speed; adjustable curve; SELV |
| | Ain2 I | Analog input 2; Measured value; 4-20 mA; Ri=100 Ω ; adjustable curve, only for use as alternative to input Ain2 U, SELV |

| Terminal | Connection | Assignment/function |
|----------|------------|---|
| KL3 | + 20 V | Fixed voltage output 20 VDC, + 20 V +25/-10%, max. 50 mA, short-circuit-proof, Power supply for external devices (e.g. sensors); SELV Alternative + 24 VDC input for parameterization without supply voltage |
| | Ain2 U | Analog input 2; Measured value; 0-10 V; Ri=100 kΩ; adjustable curve, only for use as alternative to input Ain2 I, SELV |
| | GND | Reference ground for control interface; SELV |
| | Din3 | Digital input 3: Direction of action of integrated controller, according to EEPROM setting, the direction of action of the integrated controller can be selected via bus or via digital input Din3. Normal: Pin open or applied voltage 5-50 VDC; Inverse: Bridge to GND or applied voltage < 1 VDC; SELV |
| | Din2 | Digital input 2: Switching parameter sets 1/2; according to EEPROM setting, the valid or used parameter set can be selected via bus or via digital input Din2. Parameter set 1: Pin open or applied voltage 5-50 VDC; Parameter set 2: Bridge to GND or applied voltage < 1 VDC; SELV |



ebm-papst FanScout

Click your way to the ideal RadiCal



With the FanScout selection software from ebm-papst, you can quickly and easily find the ideal product for your exact requirements from our extensive product range.

Fans operated in parallel, so-called FanGrids, are also included in the selection.

The software can be easily integrated into your device configuration program using the DLL interface.

Since our software is based on real measured values, the data you get with ebm-papst FanScout will always be absolutely reliable and above all extremely accurate.

This has been confirmed by TÜV SÜD, the German technical service organization. It assigned the accuracy of FanScout's calculations in comparison with real measurements to the highest class.

In a short time, not only can you find the best solution for your use case, you can also simulate various operating scenarios that take the fans' operating points, operating times and space requirements into account to provide you with an estimate of annual energy consumption.

To make the decision even easier for you, ebm-papst FanScout also takes life cycle costs into account: the purchase price and the operating and service costs.

ebm-papst FanScout is available to our customers only.

Please contact your ebm-papst representative or call us at +49 7938 81-0.

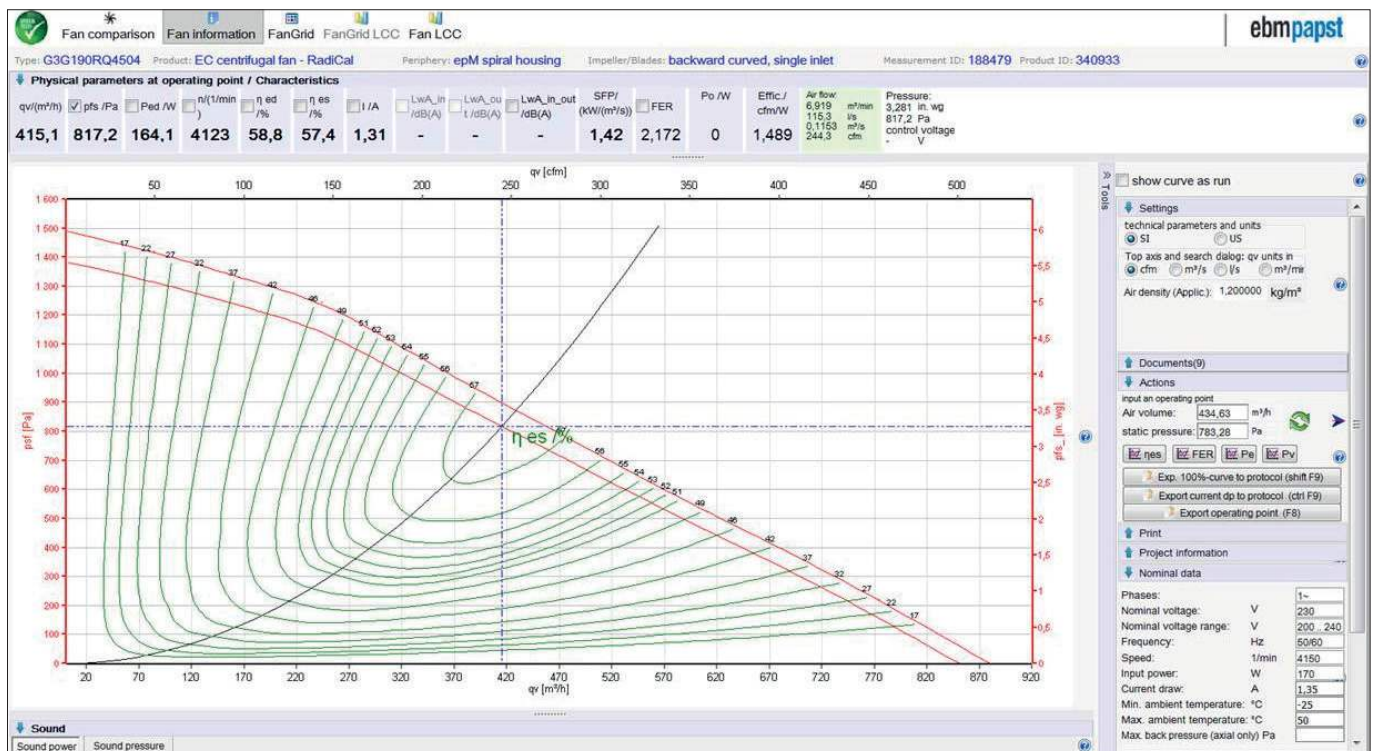

Technical parameters and scope

High standards for all ebm-papst products

At ebm-papst we are always looking to improve our products to be able to offer customers just what they need for their particular requirements. Careful monitoring of the market enables us to constantly incorporate enhancements into our products. As shown by the technical parameters listed below, you can always be sure of finding the right solution from ebm-papst for whatever application you may have in mind.

General performance parameters

Any deviations from the technical data and technical parameters described here are given in the product-specific data sheet.

Degree of protection

The degree of protection is specified in the product-specific data sheets.

Insulation class

The insulation class is specified in the product-specific data sheets.

Installation position

The installation position is specified in the product-specific data sheets.

Condensation drainage holes

Information on condensation drainage holes is provided in the product-specific data sheets.

Mode of operation

The mode of operation is specified in the product-specific data sheets.

Protection class

The protection class is specified in the product-specific data sheets.

Service life

The service life of ebm-papst products depends on two main factors:

- The service life of the insulation system
- The service life of the bearing system

The service life of the insulation system is essentially governed by the voltage level, the temperature and the ambient conditions such as humidity and condensation.

The service life of the bearing system is primarily governed by the thermal load on the bearings. For the majority of our products we use maintenance-free ball bearings which can be fitted in any installation position. Sleeve bearings can alternatively be employed, as described in the product-specific data sheets.

As a rough guide (depending on the general conditions), the ball bearings have a life expectancy L10 of approx. 40,000 hours of operation at an ambient temperature of 40 °C.

We will gladly provide you with a life expectancy calculation based on your specific usage conditions.

Motor protection/thermal protection

Information on motor protection and thermal protection is provided in the product-specific data sheets.

The following protection methods are provided depending on the type of motor and area of application:

- Thermal overload protector, in-circuit or external
- PTC with electronic diagnostics
- Impedance protection
- Thermal overload protector with electronic diagnostics
- Current limitation via electronics

If use is made of an external thermal overload protector, a commercially available tripping unit must be connected by the customer for shut-off.

Motor protection conforming to the applicable standard must be fitted for products not provided with a built-in thermal overload protector and not protected against improper use.

Mechanical strain/performance parameters

All ebm-papst products are subjected to comprehensive testing in conformity with the normative specifications and also incorporating the extensive experience of ebm-papst.



Vibration testing

Vibration testing is performed as follows:

- Vibration test in operation according to DIN IEC 68 Part 2-6
- Vibration test at standstill according to DIN IEC 68 Part 2-6

Shock load

Shock load testing is performed as follows:

- Shock load according to DIN IEC 68 Part 2-27

Balancing grade

Balancing grade testing is performed as follows:

- Residual imbalance according to DIN ISO 1940
- Standard balancing quality level G 6.3

Should your particular application require a higher level of balancing, please contact us and specify the details in your order.

Chemical and physical strain/performance parameters

Please consult your ebm-papst contact for any questions regarding chemical and physical strain.

Areas of use, industries & applications

Our products are used in a variety of industries and for numerous applications:

Ventilation, air conditioning and refrigeration technology, clean room technology, automotive and railway engineering, medical and laboratory technology, electronics, computer and office systems, telecommunications, household appliances, heating systems, machinery and installations, drive engineering.

Our products are not intended for use in the aerospace industry!

Legal and normative specifications

The products described in this catalog are developed and manufactured in accordance with the standards applying to the particular product and, if known, in accordance with the conditions of the particular area of application.

Standards

Information on standards is provided in the product-specific data sheets.

EMC

Information on EMC standards is provided in the product-specific data sheets.

Compliance with EMC standards has to be assessed on the final product, as EMC properties may change under different installation conditions.

Touch current

Information on touch current is provided in the product-specific data sheets.

Measurement is performed according to IEC 60990.

Approvals

Please contact us if you require a specific type of approval (VDE, UL, GOST, CCC, CSA, etc.) for your ebm-papst product.

Most of our products can be supplied with the applicable approval.

Information on existing approvals is provided in the product-specific data sheets.

Air performance measurements

All air performance measurements are conducted on intake-side chamber test rigs conforming to the requirements of ISO 5801 and DIN 24163. The fans under test are attached to the measuring chamber with free air intake and exhaust (installation category A) and operated at nominal voltage, with alternating current also at nominal frequency, without any additional attachments such as a guard grill.

As required by the standards, the air performance curves shown are referenced to an air density of 1.15 kg/m^3 .

Technical parameters and scope



Air and sound measurement conditions

Measurements on ebm-papst products are taken under the following conditions:

- Axial and diagonal fans in airflow direction “V” in full nozzle without guard grill
- Backward-curved centrifugal fans, free-running with inlet ring
- Forward-curved single and dual-inlet centrifugal fans with housing
- Backward-curved dual-inlet centrifugal fans with housing

Sound measurements

All sound measurements are taken in anechoic rooms with reverberant floor. ebm-papst acoustic test chambers meet the requirements of accuracy class 1 as per DIN EN ISO 3745. For sound measurement, the fans being tested are positioned in a reverberant wall and operated at nominal voltage, with alternating current also at nominal frequency, without any additional attachments such as a guard grill.

Sound pressure and sound power level

All acoustic values are determined in accordance with ISO 13347, DIN 45635 and ISO 3744/3745 as per accuracy class 2 and given in A-rated form.

For measurement of the sound pressure level L_p the microphone is located on the intake side of the fan being tested, generally at a distance of 1 m on the fan axis.

For measurement of the sound power level L_W 10 microphones are distributed over an enveloping surface on the intake side of the fan being tested (see graphic). The measured sound power level can be roughly calculated from the sound pressure level by adding 7 dB.

Measurement set-up according to ISO 13347-3 and DIN 45635-38:

- 10 measuring points

$d \geq D$

$h = 1.5d \dots 4.5d$

Measurement area $S = 6d^2 + 7d(h + 1.5d)$

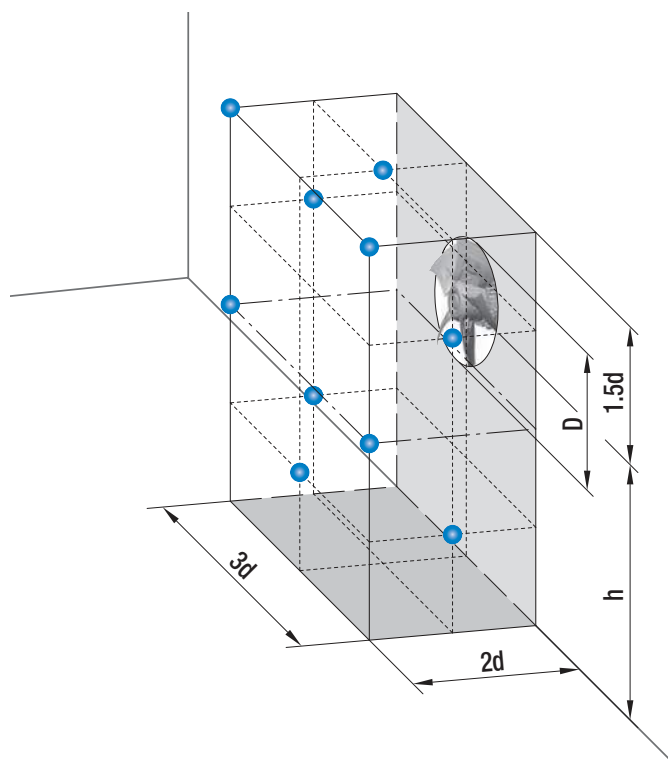



Cumulative level of several sound sources with the same level

The addition of 2 sound sources with the same level produces a level increase of approx. 3 dB. The noise characteristics of several identical fans can be predicted on the basis of the sound values specified in the data sheet. This is shown in the adjacent graph.

Example: There are 8 axial fans A3G800 on a condenser. According to the data sheet, the sound pressure level of one fan is 75 dB(A). The level increase determined from the graph is 9 dB. This means that a total level of 84 dB(A) is to be expected for the installation.

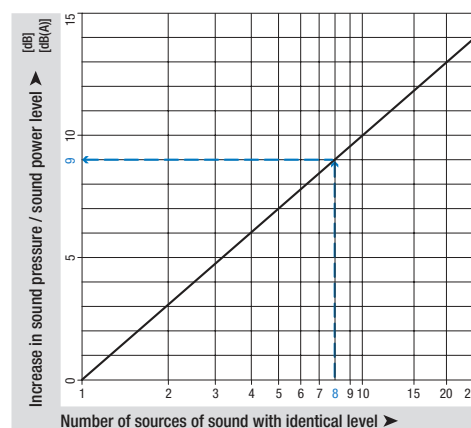

Cumulative level of two sound sources with different levels

The noise characteristics of two different fans can be predicted on the basis of the sound values specified in the data sheet. This is shown in the adjacent graph.

Example: In a ventilation unit, there is one axial fan A3G800 with a sound pressure level of 75 dB(A) at the point of operation and one axial fan A3G710 with 71 dB(A). The difference in level is 4 dB. The level increase of approx. 1.5 dB can now be read off the graph. This means that a total level of 76.5 dB(A) is to be expected for the unit.

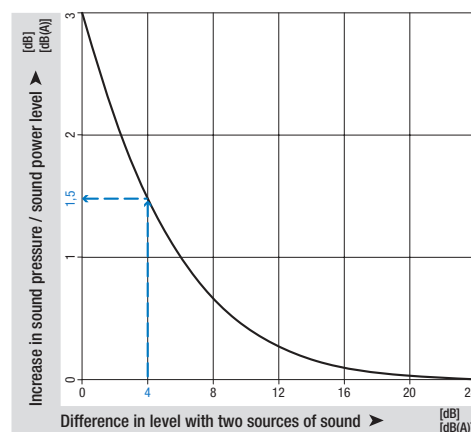

Distance laws

The sound power level is not governed by the distance from the noise source. By contrast, the sound pressure level decreases with increasing distance from the sound source. The adjacent graph shows the decrease in level under far field conditions. Far field conditions apply if there is a considerable distance between the microphone and the fan in relation to the fan diameter and the wavelength under consideration. On account of the complexity of the topic, literature should be consulted for more detailed information on far fields. The level in the far field decreases by 6 dB each time the distance is doubled. Different relationships apply in the near field of the fan and the level may decrease to a far lesser extent. The following example only applies to far field conditions and may vary considerably as a result of installation effects:

For an axial fan A3G300, a sound pressure level of 65 dB(A) was measured at a distance of 1 m. From the adjacent graph, this would yield a reduction of 26 dB at a distance of 20 m, i.e. a sound pressure level of 39 dB(A).

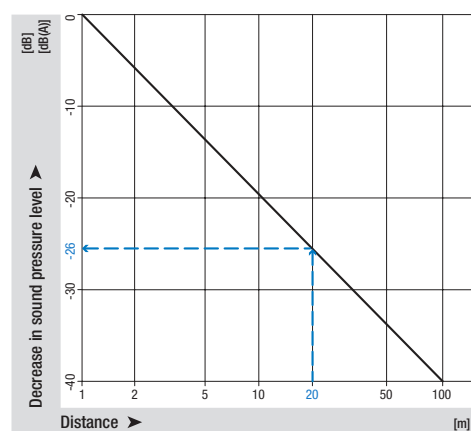

ebm-papst in Germany

ebm-papst Mulfingen GmbH & Co. KG

Bachmühle 2
74673 Mulfingen
GERMANY
Phone +49 7938 81-0
Fax +49 7938 81-110
info1@de.ebmpapst.com

ebm-papst St. Georgen GmbH & Co. KG

Hermann-Papst-Straße 1
78112 St. Georgen
GERMANY
Phone +49 7724 81-0
Fax +49 7724 81-1309
info2@de.ebmpapst.com

ebm-papst Landshut GmbH

Hofmark-Aich-Straße 25
84030 Landshut
GERMANY
Phone +49 871 707-0
Fax +49 871 707-465
info3@de.ebmpapst.com

 **Berlin**
Dipl.-Ing. (TH) Jens Duchow
Händelstraße 7
16341 Panketal
GERMANY
Phone +49 30 944149-62
Fax +49 30 944149-63
Jens.Duchow@de.ebmpapst.com

 **Bielefeld**
Dipl.-Ing. (FH) Wolf-Jürgen Weber
Niehausweg 13
33739 Bielefeld
GERMANY
Phone +49 5206 91732-31
Fax +49 5206 91732-35
Wolf-Juergen.Weber@de.ebmpapst.com

 **Dortmund**
Dipl.-Ing. (FH) Hans-Joachim Pundt
Auf den Steinern 3
59519 Möhnese-Völlinghausen
GERMANY
Phone +49 2925 800-407
Fax +49 2925 800-408
Hans-Joachim.Pundt@de.ebmpapst.com

 **Frankfurt**
Dipl.-Ing. Christian Kleffmann
Dr.-Hermann-Krause-Straße 23
63452 Hanau
GERMANY
Phone +49 6181 1898-12
Fax +49 6181 1898-13
Christian.Kleffmann@de.ebmpapst.com

 **Halle**
Dipl.-Ing. (TU) Michael Hanning
Lercheneck 4
06198 Salztal / OT Lieskau
GERMANY
Phone +49 345 55124-56
Fax +49 345 55124-57
Michael.Hanning@de.ebmpapst.com

 **Hamburg**
Ingenieurbüro Breuell GmbH
Ing. Dirk Kahl
Elektroingenieur
Oststraße 96
22844 Norderstedt
GERMANY
Phone +49 40 538092-19
Fax +49 40 538092-84
Kahl@breuell-hilgenfeldt.de

 **Heilbronn / Heidelberg**
Wolfgang Richter
Büttelsbergweg 18
97980 Bad Mergentheim-Rengershausen
GERMANY
Phone +49 7937 32200-33
Fax +49 7938 81-110
Wolfgang.Richter@de.ebmpapst.com

 **Kassel**
Dipl.-Ing. (FH) Ralph Brück
Hoherainstraße 3 b
35075 Gladenbach
GERMANY
Phone +49 6462 4071-10
Fax +49 6462 4071-11
Ralph.Brueck@de.ebmpapst.com

 **Koblenz**
Winfried Schaefer
Hinter der Kirch 10
56767 Uersfeld
GERMANY
Phone +49 2657 16-96
Fax +49 2657 16-76
Winfried.Schaefer@de.ebmpapst.com

 **Munich**
Dipl.-Wirt.-Ing. (FH) Jens Peter
Landsbergerstraße 14
86932 Pürgen
GERMANY
Phone +49 8196 99877-54
Fax +49 8196 99877-55
Jens.Peter@de.ebmpapst.com

 **Nuremberg**
Dipl.-Wirt.-Ing. (FH) Axel Resch
Dr.-August-Koch-Str. 1
91639 Wolframs-Eschenbach
GERMANY
Phone +49 9875 9783-170
Fax +49 9875 9783-171
Axel.Resch@de.ebmpapst.com

 **Offenburg**
Dipl.-Ing. (FH) Ralf Braun
Hubeneck 21
77704 Oberkirch
GERMANY
Phone +49 7802 9822-52
Fax +49 7802 9822-53
Ralf.Braun@de.ebmpapst.com

 **Stuttgart**
Dipl.-Ing. (FH) Rudi Weinmann
Hindenburgstraße 100/1
73207 Plochingen
GERMANY
Phone +49 7153 9289-80
Fax +49 7153 9289-81
Rudi.Weinmann@de.ebmpapst.com

 **Ulm**
M.Sc. Reinhard Sommerreißer
Einsteinstraße 7a
86674 Baar / Schwaben
GERMANY
Phone +49 8276 5899-775
Fax +49 7938 81-110
Reinhard.Sommerreisser@de.ebmpapst.com

Distributors

 **Frankfurt**
R.E.D. Handelsgesellschaft mbH
Gutenbergstraße 3
63110 Rodgau - Jügesheim
GERMANY
Phone +49 6106 841-0
Fax +49 6106 841-111
info@red-elektromechanik.de
www.red-elektromechanik.de

 **Hamburg**
Breuell + Hilgenfeldt GmbH
Oststraße 96
22844 Norderstedt
GERMANY
Phone +49 40 538092-20
Fax +49 40 538092-84
info@breuell-hilgenfeldt.de

 **Munich**
A. Schweiger GmbH
Ohmstraße 1
82054 Sauerlach
GERMANY
Phone +49 8104 897-0
Fax +49 8104 897-90
info@schweiger-gmbh.de
www.schweiger-gmbh.com

● **Express Service-Center** (1 to 5 pieces)

 **North**
Breuell + Hilgenfeldt GmbH
Oststraße 96
22844 Norderstedt
GERMANY
Phone +49 40 538092-20
Fax +49 40 538092-84
info@breuell-hilgenfeldt.de

 **South**
HDS Ventilatoren Vertriebs GmbH
Glaswiesenstraße 1
74677 Dörzbach
GERMANY
Phone +49 7937 80355-20
Fax +49 7937 80355-25
info@hds-gmbh.net
www.hds-gmbh.net

ebm-papst in Europe



Europe



Austria

ebm-papst Motoren & Ventilatoren GmbH
Straubingstraße 17
4030 Linz
AUSTRIA
Phone +43 732 321150-0
Fax +43 732 321150-20
info@at.ebmpapst.com
www.ebmpapst.at



Belarus

ebm-papst Bel AgmbH
4th Montazhnikov side street
House 6, Office 332
BY-220019 Minsk
BELARUS
Phone +375 17 2015216
Fax +375 17 2015216
info@by.ebmpapst.com
www.ebmpapst.by



Belgium

ebm-papst Benelux B.V.
Sales office Belgium-Luxemburg
Romeinsestraat 6/0101
Research Park Haasrode
3001 Heverlee-Leuven
BELGIUM
Phone +32 16 396-200
Fax +32 16 396-220
info@be.ebmpapst.com
www.ebmpapst.be



Bulgaria

ebm-papst Romania S.R.L.
Str. Tarnavei No. 20
500327 Brasov
ROMANIA
Phone +40 268 331859
Fax +40 268 312805
dudasludovic@xnet.ro



Croatia

ebm-papst Industries Kft.
Ezred u. 2.
1044 Budapest
HUNGARY
Phone +36 1 8722-190
Fax +36 1 8722-194
office@hu.ebmpapst.com



Cyprus

Helcoma
E. Rota and Co. OE
Davaki 65
17672 Kallithea-Attiki
GREECE
Phone +30 210 9513-705
Fax +30 210 9513-490
contact@helcoma.gr
www.helcoma.gr



Czech Republic / Slovakia

ebm-papst CZ s.r.o.
Kaštanová 34a
620 00 Brno
CZECH REPUBLIC
Phone +420 544 502-411
Fax +420 547 232-622
info@ebmpapst.cz
www.ebmpapst.cz



Denmark

ebm-papst Denmark ApS
Vallensbækvej 21
2605 Brøndby
DENMARK
Phone +45 43 631111
Fax +45 43 630505
mail@dk.ebmpapst.com
www.ebmpapst.dk



Estonia

ebm-papst Oy, Eesti Filiaal
Kesk tee 21
Aaviku küla, Jüri Tehnopark
75301 Rae Vald, Harjumaa
ESTONIA
Phone +372 65569-78
www.ebmpapst.ee



Finland

ebm-papst Oy
Puistotie 1
02760 Espoo
FINLAND
Phone +358 9 887022-0
Fax +358 9 887022-13
mailbox@ebmpapst.fi
www.ebmpapst.fi



France

ebm-papst sarl
Parc d'Activités Nord
1 rue Mohler – BP 62
67212 Obernai Cedex
FRANCE
Phone +33 3 88 66 88 03
info@ebmpapst.fr
www.ebmpapst.fr



Greece

HELCOMA
HELLAS IKE
65, Davaki street
17672 Kallithea-Attiki
GREECE
Phone +30 210 9513-705
Fax +30 210 9513-490
contact@helcoma.gr
www.helcoma.gr



Hungary

ebm-papst Industries Kft.
Ezred u. 2.
1044 Budapest
HUNGARY
Phone +36 1 8722-190
Fax +36 1 8722-194
office@hu.ebmpapst.com



Iceland

RJ Engineers
Stangarhyl 1a
110 Reykjavik
ICELAND
Phone +354 567 8030
Fax +354 567 8015
rj@rj.is
www.rj.is



Ireland

ebm-papst UK Ltd.
Chelmsford Business Park
Chelmsford Essex CM2 5EZ
UNITED KINGDOM
Phone +44 1245 468555
Fax +44 1245 466336
sales@uk.ebmpapst.com
www.ebmpapst.co.uk



AuBren Limited

Portlaoise Business & Technology Park
Mountrath Road
Portlaoise, Co. Laois
IRELAND
Phone +353 57 8664343
Fax +353 57 8664346
sales@ie.aubren.com
www.aubren.com



Italy

ebm-papst Srl
Via Cornaggia 108
22076 Mozzate (Co)
ITALY
Phone +39 0331 836201
Fax +39 0331 821510
info@it.ebmpapst.com
www.ebmpapst.it

ebm-papst in Europe



 **Macedonia**
ebm-papst Industries Kft.
Ezred u. 2.
1044 Budapest
HUNGARY
Phone +36 1 8722-190
Fax +36 1 8722-194
office@hu.ebmpapst.com

 **Netherlands**
ebm-papst Benelux B.V.
Polbeemd 7 - 5741 TP Beek en Donk
P.O. Box 140 - 5740 AC Beek en Donk
NETHERLANDS
Phone +31 492 502-900
Fax +31 492 502-950
verkoop@nl.ebmpapst.com
www.ebmpapst.nl

ebm-papst Heating Systems B.V.
Van Veldekekade 360
5216 KT 's-Hertogenbosch
NETHERLANDS
Phone +31 73 648 89 00
Fax +31 73 648 89 11
info@ebmpapst-hs.nl
www.ebmpapst-hs.nl

 **Norway**
ebm-papst AS
P.B. 173 Holmlia
1203 Oslo
NORWAY
Phone +47 22 763340
Fax +47 22 619173
mailbox@ebmpapst.no
www.ebmpapst.no

 **Poland**
ebm-papst Polska Sp. z o.o.
ul. Annopol 4A
03236 Warszawa
POLAND
Phone +48 22 6757819
Fax +48 22 6769587
office@ebmpapst.pl
www.ebmpapst.pl

 **Portugal**
ebm-papst (Portugal), Lda.
Centro Empresarial de Alverca
Rua de Adarse, Vale D'Ervas
Corpo D / Fracção 3
2615-178 Alverca do Ribatejo
PORTUGAL
Phone +351 218 394 880
Fax +351 218 394 759
info@pt.ebmpapst.com
www.ebmpapst.pt

 **Romania**
ebm-papst Romania S.R.L.
Str. Tarnavei Nr. 20
500327 Brasov
ROMANIA
Phone +40 268 331859
Fax +40 268 312805
dudasludovic@xnet.ro

 **Russia**
ebm-papst Rus GmbH
Olimpiyskiy prospect 29A, office 418
141006 Mytistschi, Oblast Moskau
RUSSIA
Phone +7 495 9807524
Fax +7 495 5140924
info@ebmpapst.ru
www.ebmpapst.ru

 **ebm-papst Ural GmbH**
Posadskaja-Strasse, 23(E), 3
620102 Ekaterinburg
RUSSIA
Phone +7 343 2338000
Fax +7 343 2337788
Konstantin.Molokov@ru.ebmpapst.com
www.ebmpapst.ru

 **Serbia & Montenegro**
ebm-papst Industries Kft.
Ezred u. 2.
1044 Budapest
HUNGARY
Phone +36 1 8722-190
Fax +36 1 8722-194
office@hu.ebmpapst.com

 **Spain**
ebm-papst Ibérica S.L.
Avda. del Sistema Solar, 29
28830 San Fernando de Henares (Madrid)
SPAIN
Phone +34 91 6780894
Fax +34 91 6781530
ventas@ebmpapst.es
www.ebmpapst.es

 **Sweden**
ebm-papst AB
Äggelundavägen 2
17562 Järfälla
SWEDEN
Phone +46 10 4544400
Fax +46 8 362306
info@ebmpapst.se
www.ebmpapst.se

 **Switzerland**
ebm-papst AG
Rütisbergstrasse 1
8156 Oberhasli
SWITZERLAND
Phone +41 44 73220-70
Fax +41 44 73220-77
verkauf@ebmpapst.ch
www.ebmpapst.ch

 **Turkey**
Akantel Elektronik San. Tic. LTD. Sti.
Atatürk Organize Sanayi
Bölgesi 10007 SK. No.:6
35620 Cigli-Izmir
TURKEY
Phone +90 232 3282090
Fax +90 232 3280270
akantel@akantel.com.tr
www.ebmpapst.com.tr

 **Ukraine**
ebm-papst Ukraine LLC
Lepse Boulevard, 4, Building 21
03067 Kiev
UKRAINE
Phone +38 044 2063091
Fax +38 044 2063091
mail@ebmpapst.ua
www.ebmpapst.ua

 **United Kingdom**
ebm-papst UK Ltd.
Chelmsford Business Park
Chelmsford Essex CM2 5EZ
UNITED KINGDOM
Phone +44 1245 468555
Fax +44 1245 466336
sales@uk.ebmpapst.com
www.ebmpapst.co.uk

 **ebm-papst Automotive & Drives (UK) Ltd.**
The Smithy
Fidlers Lane
East Ilsley, Berkshire RG20 7LG
UNITED KINGDOM
Phone +44 1635 2811-11
Fax +44 1635 2811-61
A&Dsales@uk.ebmpapst.com
www.ebmpapst-ad.com

ebm-papst in America and Africa

America

 **Argentina**
 ebm-papst Argentina S.A.
 Parque Industrial Canning Etapa II - Nave 61A
 Perito Moreno 845, Canning (1804), Buenos Aires
 ARGENTINA
 Phone +54 11 46576135
 Fax +54 11 46572092
 ventas@ar.ebmpapst.com
 www.ebmpapst.com.ar

 **Brazil**
 ebm-papst Motores Ventiladores Ltda.
 Av. José Giorgi, 301 Galpões B6+B7
 Condomínio Logical Center
 06707-100 Cotia - São Paulo
 BRAZIL
 Phone +55 11 4613-8700
 Fax +55 11 4777-1456
 vendas@br.ebmpapst.com
 www.ebmpapst.com.br



 **Canada**
 ebm-papst Canada Inc.
 1800 Ironstone Manor, Unit 2
 Pickering, Ontario, L1W3J9
 CANADA
 Phone +1 905 420-3533
 Fax +1 905 420-3772
 sales@ca.ebmpapst.com
 www.ebmpapst.ca

 **Mexico**
 ebm Industrial S. de R.L. de C.V.
 Paseo de Tamarindos 400-A-5to Piso
 Col. Bosques de las Lomas
 Mexico 05120, D.F.
 MEXICO
 Phone +52 55 3300-5144
 Fax +52 55 3300-5243
 sales@mx.ebmpapst.com
 www.ebmpapst.com.mx

USA
 ebm-papst Inc.
 P.O. Box 4009
 100 Hyde Road
 Farmington, CT 06034
 UNITED STATES
 Phone +1 860 674-1515
 Fax +1 860 674-8536
 sales@us.ebmpapst.com
 www.ebmpapst.us

 ebm-papst Inc.
 Automotive & Drives Business Unit
 3200 Greenfield Road, Suite 130
 Dearborn, MI 48120
 UNITED STATES
 Phone +1 313 406-8080
 Fax +1 313 406-8081
 automotive@us.ebmpapst.com
 www.ebmpapst-automotive.us

Africa

 **South Africa**
 ebm-papst South Africa (Pty) Ltd.
 P.O. Box 3124
 1119 Yacht Avenue
 2040 Honeydew
 SOUTH AFRICA
 Phone +27 11 794-3434
 Fax +27 11 794-5020
 info@za.ebmpapst.com
 www.ebmpapst.co.za



ebm-papst in Asia



Asia

China

   ebm-papst Ventilator (Shanghai) Co., Ltd.
No. 418, Huajing Road
WaiGaoQiao Free Trade Zone
No. 2001, Yang Gao (N) Road
200131 Shanghai
P.R. of CHINA
Phone +86 21 5046-0183
Fax +86 21 5046-1119
sales@cn.ebmpapst.com
www.ebmpapst.com.cn

Hong Kong

   ebm-papst Hong Kong Ltd.
Room 17E, MG Tower
133 Hoi Bun Road, Kwun Tong
Hong Kong
P.R. of CHINA
Phone +852 2145-8678
Fax +852 2145-7678
info@hk.ebmpapst.com

India

   ebm-papst India Pvt. Ltd.
26/3, G.N.T. Road, Erukkencherry
Chennai-600118
INDIA
Phone +91 44 25372556
Fax +91 44 25371149
sales@in.ebmpapst.com
www.ebmpapst.in

Indonesia

   ebm-papst Indonesia
Representative Office
German Centre, 4th Floor, Suite 4470
Jl. Kapt. Subijono Dj. Bumi Serpong Damai
15321 Tangerang
INDONESIA
Phone +62 21 5376250
Fax +62 21 5388305
salesdept@id.ebmpapst.com

Israel

   Polak Bros. Import Agencies Ltd.
9 Hamefalsim Street
Kiryat Arie, Petach-Tikva 49514
ISRAEL
Phone +972 3 9100300
Fax +972 3 5796679
polak@polak.co.il
www.polak.co.il

Japan

   ebm-papst Japan K.K.
Attend on Tower 13F
Shinyokohama 2-8-12, Kohoku-ku
222-0033 Yokohama-City, Kanagawa
JAPAN
Phone +81 45 47057-51
Fax +81 45 47057-52
info@jp.ebmpapst.com
www.ebmpapst.jp

Korea

   ebm-papst Korea Co. Ltd.
6F, Trutech Bldg.
12, WorldCupbuk-ro 56-gil
Mapo-Gu
Seoul 03924
KOREA
Phone +82 2 366213-24
Fax +82 2 366213-26
info@kr.ebmpapst.com
www.ebmpapst.co.kr

Malaysia

   ebm-papst Malaysia
Representative Office
No. 16-1, Jalan Putra Mahkota 7/5A
Putra Heights
Selangor Darul Ehsan
47650 Subang Jaya
MALAYSIA
Phone +60 3 5192-7688
Fax +60 3 5614-3078
salesdept@my.ebmpapst.com

Philippines

   ebm-papst SEA Pte. Ltd.
Representative Office (Philippines)
ALPAP II Building
Trade Street Corner Investment Drive
Unit 1101 Madrigal Business Park
1799 Ayala Alabang / Muntinlupa City
Telefon: +63 02 8042747
Telefax: +63 02 8042757
salesdept@ph.ebmpapst.com

Singapore

   ebm-papst SEA Pte. Ltd.
9 Tai Seng Drive
#03-01 Geo-Tele Centre, Lobby B
Singapore 535227
SINGAPORE
Phone +65 65513789
Fax +65 68428439
salesdept@sg.ebmpapst.com

Taiwan

   ETECO Engineering & Trading Corp.
10F-I, No. 92, Teh-Wei Str.
Tsow-Inn District, Kaohsiung
TAIWAN
Phone +886 7 557-4268
Fax +886 7 557-2788
eteco@ms22.hinet.net
www.ebmpapst.com.tw

Thailand

   ebm-papst Thailand Co., Ltd.
99/9 Moo 2, Central Chaengwattana Tower
14th Floor, Room 1402
Chaengwattana Road Bangtarad, Pakkret
11120 Nonthaburi
THAILAND
Phone +66 2 8353785-7
Fax +66 2 8353788
salesdept@th.ebmpapst.com

United Arab Emirates

   ebm-papst Middle East FZE
PO Box 17755
Jebel Ali Free Zone / FZS1 / AP05
Dubai
UNITED ARAB EMIRATES
Phone +971 4 88608-26
Fax +971 4 88608-27
info@ae.ebmpapst.com
www.ebmpapst.ae

Vietnam

   ebm-papst SEA Pte. Ltd.
Representative Office (Vietnam)
Floor M, Phuong Long Building,
506 Nguyen Dinh Chieu Street,
Ward 4, District 3,
Ho Chi Minh City, Vietnam
VIETNAM
Phone +84 28 3929 0699 / 3929 0670
Fax +84 28 3929 0669
salesdept@vn.ebmpapst.com

ebm-papst in Oceania

Oceania



Australia

ebm-papst A&NZ Pty Ltd.
10 Oxford Road
Laverton North, Victoria, 3026
AUSTRALIA
Phone +61 3 9360-6400
Fax +61 3 9360-6464
sales@ebmpapst.com.au
www.ebmpapst.com.au



New Zealand

ebm-papst A&NZ Pty Ltd.
61 Hugo Johnston Drive, Unit H
Penrose 1061, Auckland
NEW ZEALAND
PO Box 112278,
Penrose 1642, Auckland
Phone +64 9 525-0245
Fax +64 9 525-0246
sales@ebmpapst.com.au
www.ebmpapst.com.au





ebm-papst
Mulfingen GmbH & Co. KG

Bachmühle 2
74673 Mulfingen
Germany
Phone +49 7938 81-0
Fax +49 7938 81-110
info1@de.ebmpapst.com

ebmpapst

The engineer's choice