

REVISIONS				
REV	DESCRIPTION	DATE	GUARDIAN	APPROVED
C	EAR 15058	AUG10/22	-	S. MUGAN
D	EAR 15058	JUN21/23	-	M. PAHULJE



ORDERING CODE: FLH - S X 1 - 9X - X

FLH SERIES

PLUG HOUSING (FOR SOCKET CONTACTS)

HOUSING SIZE
 3 = FOR UP TO 3 CONTACTS
 6 = FOR UP TO 6 CONTACTS

WIRE END CONNECTOR, FOR CRIMP CONTACTS

IP RATING
 90 = IP20, SEE NOTE 4

OTHER OPTIONS
 LEAVE BLANK FOR STANDARD

FOR CUSTOM REQUESTS, CONSULT AN AMPHENOL REPRESENTATIVE.

TABLE 1: HOUSING WIDTH

HOUSING SIZE	HOUSING WIDTH (DIMENSION 'W')
3	10.30 [.406]
6	17.80 [.701]

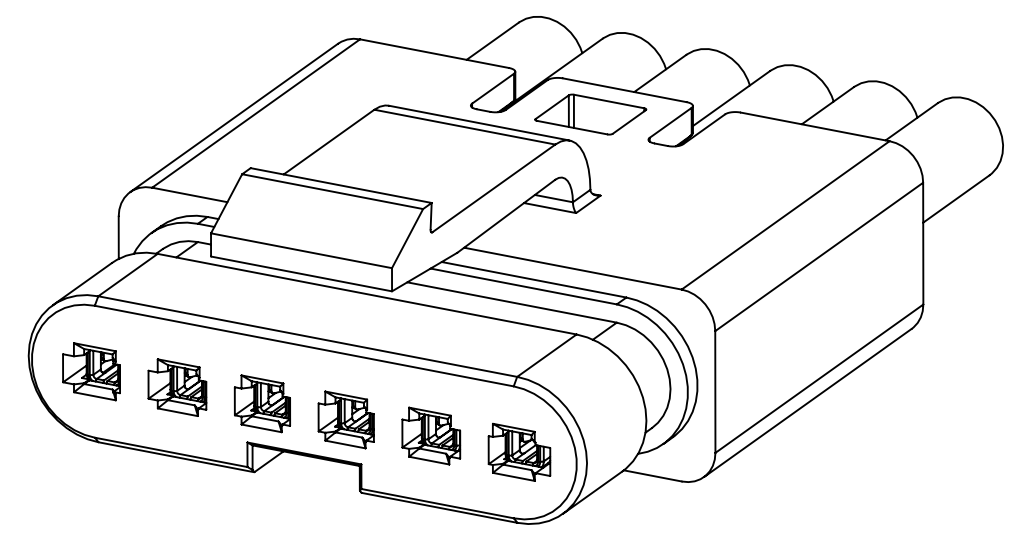
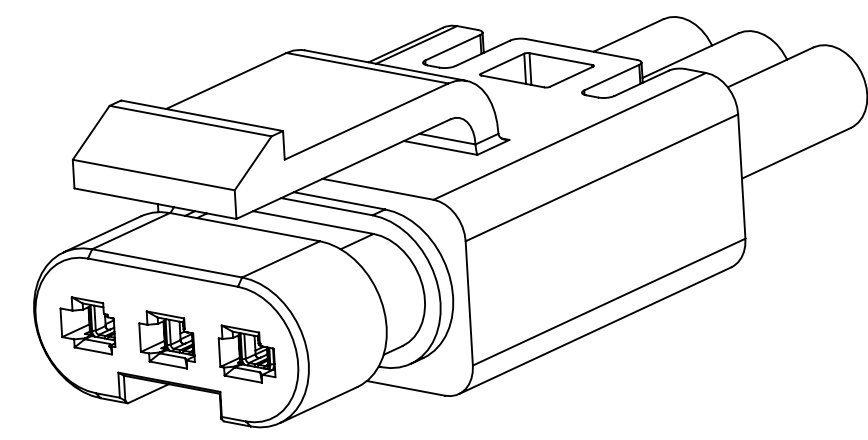
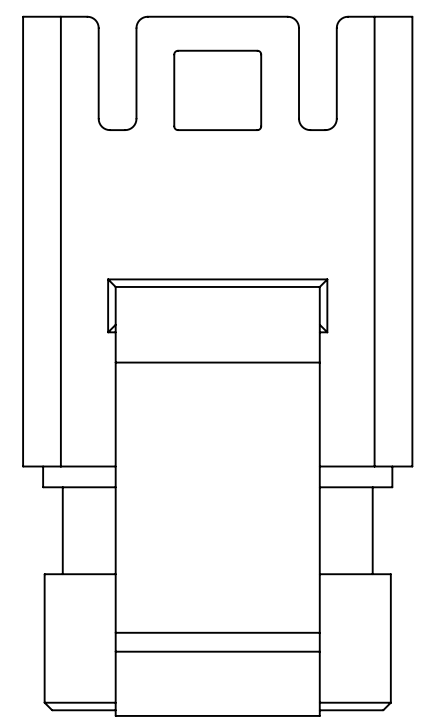

END CONNECTOR ASSEMBLY WITH 3 CONTACTS CRIMPED TO WIRES AND INSTALLED

END CONNECTOR ASSEMBLY WITH 6 CONTACTS CRIMPED TO WIRES AND INSTALLED

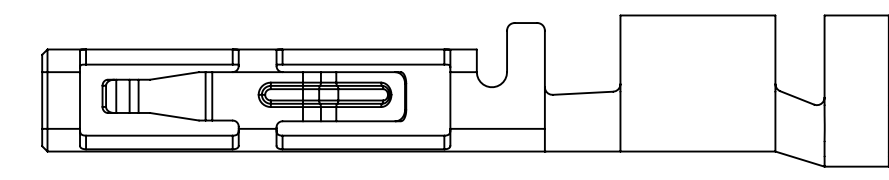
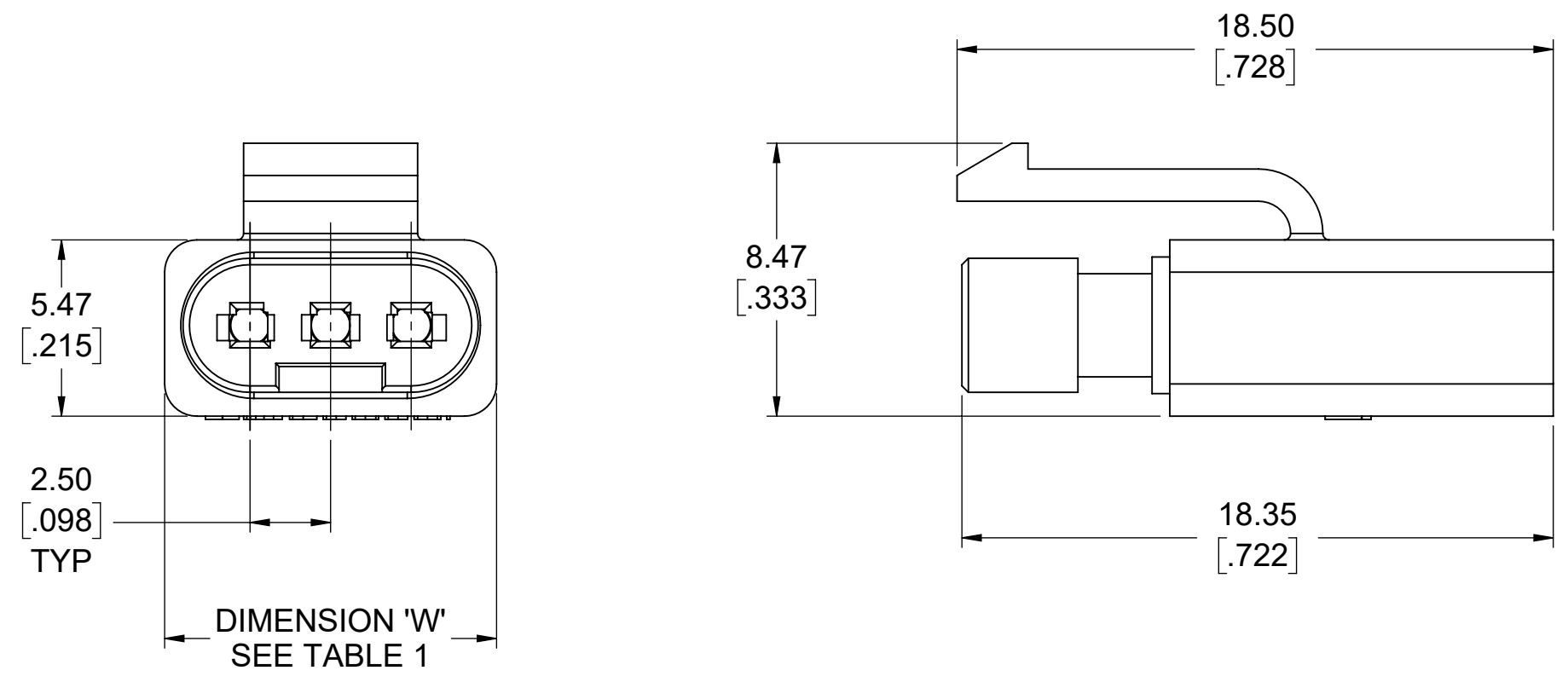

FLH-SC136-1-XXX - SOCKET CONTACT
 SEE NOTES 3 & 5
 SCALE 10:1

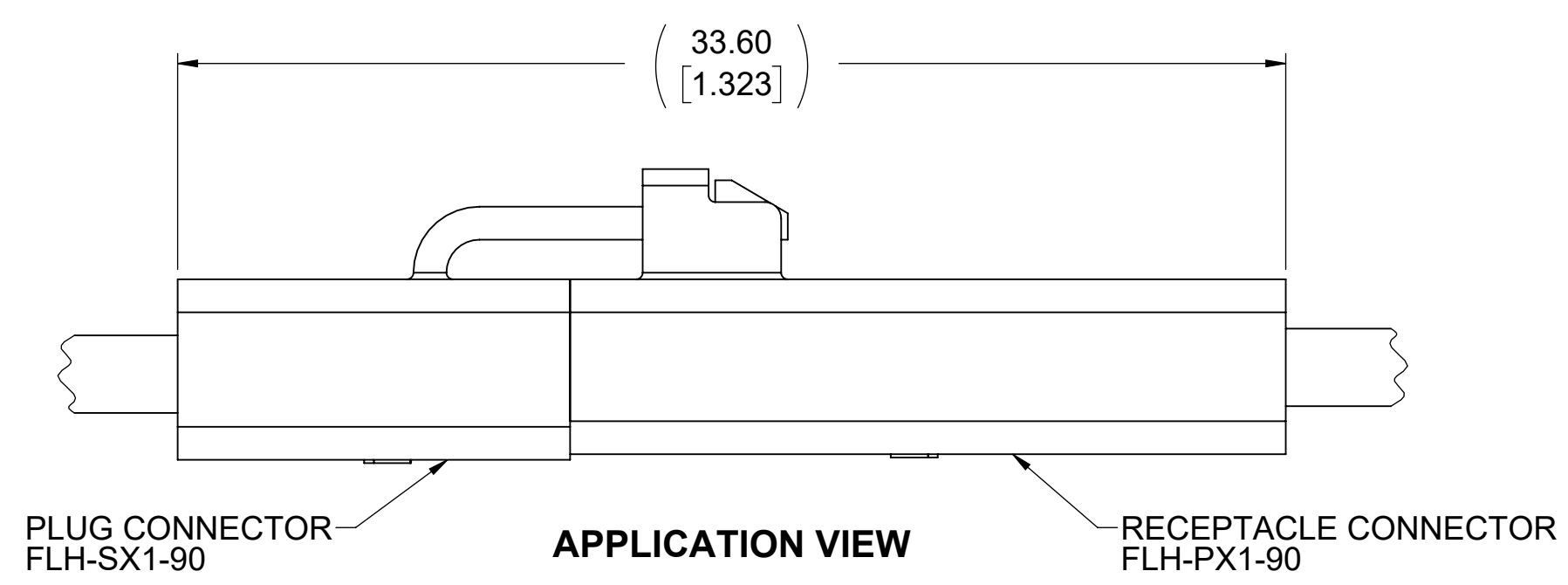

NOTES:

- ALL MATERIALS ARE RoHS COMPLIANT PER EU DIRECTIVE 2011/65/EU & AMENDMENTS:
 - HOUSING: ENGINEERING THERMOPLASTIC, FLAMMABILITY RATING UL94 V-0, COLOUR BLACK
- ELECTRICAL CHARACTERISTICS:
 - CURRENT RATING: 7 A (18 AWG OR 1 mm²) OR 5 A (20 AWG OR 0.5 mm²) OR 3 A (22 AWG OR 0.34 mm²) PER CONTACT
 - DIELECTRIC WITHSTANDING VOLTAGE: 1500 VAC
 - INSULATION RESISTANCE: 500 MΩ
 - OPERATING TEMPERATURE: -40 °C TO +105 °C
- CRIMP STRANDED WIRE TO CONTACT BEFORE ASSEMBLING INTO HOUSING
- IP20 PROTECTION PER IEC 60529 IN MATED & UNMATED CONDITION
- SOCKET CONTACTS TO BE PURCHASED SEPARATELY ON REEL, P/N: FLH-SC136-1-XXX

UNLESS SPECIFIED OTHERWISE	DRAWN	S. MUGAN	JUN02/22
PRIMARY UNITS MILLIMETRES	CHECKED		
SECONDARY INCHES	M.E. APP'D		
REFERENCE IN PARENTHESES	Q.A. APP'D		
GENERAL TOLERANCES	DWG APP'D	S. MUGAN	JUN02/22
1 DECIMAL PLACE	ENG NO.	EAR 15074	
2 DECIMAL PLACES ±0.10	RELEASE STATE	Released	
3 DECIMAL PLACES	THIRD ANGLE PROJECTION		
ANGULAR DEGREES	DO NOT SCALE DRAWING		

Amphenol Canada Corp.
 Commercial Products

FLH SERIES, MINI 2.5 mm PITCH, PLUG HOUSING, FOR 1 TO 6 CONTACTS, RoHS COMPLIANT

DWG. NO. **P-FLH-SX1-9X-X** REV **D**

CODE ID NO. 03554 DWG SIZE: C SCALE: 5:1 SHEET 1 OF 1