

REVISIONS					
P	LTR	DESCRIPTION	DATE	DMN	APVD
A		RELEASED PER ECO-19-009368	19JUN2019	RS	DH

- 1 CONTINUOUS STRIP ON REELS.
- 2 WIRE SIZE IS 22-12 AWG
- 3 INSULATION RANGE IS [.074 - .157]
- 4 MATING TAB THK IS .032 ± .001
- 5 NOTE NOT USED
- 6  CONTACT ROLLS TO NOT TOUCH EACH OTHER.

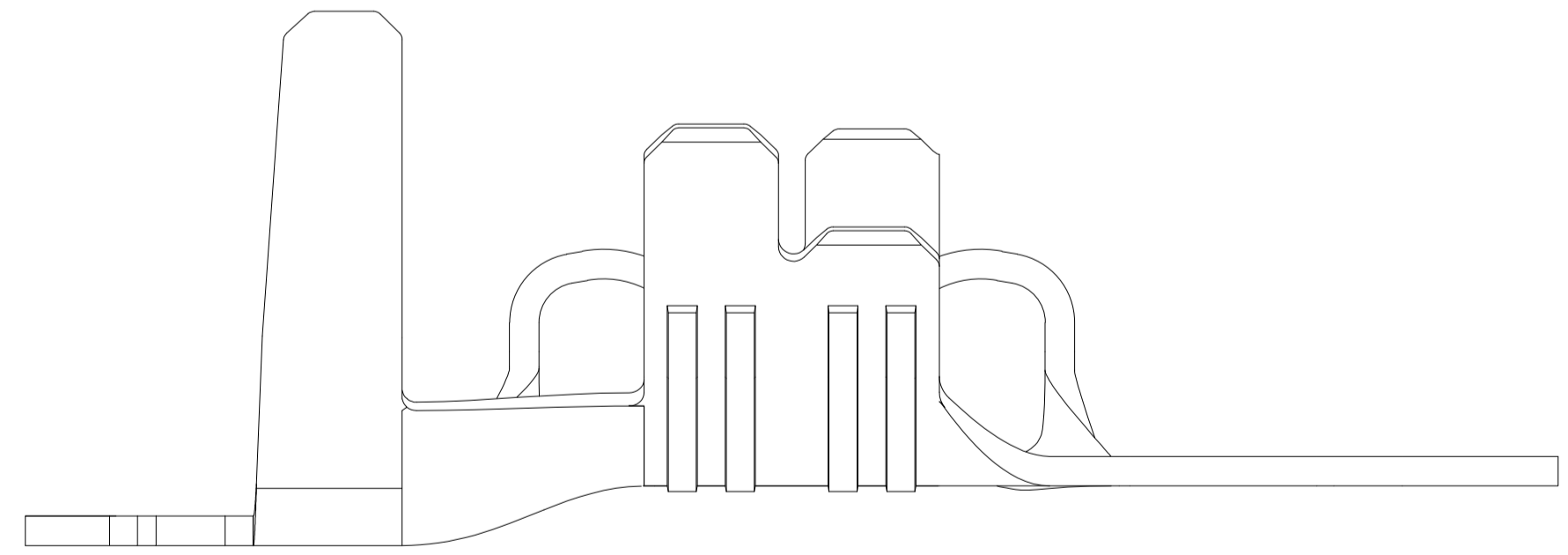
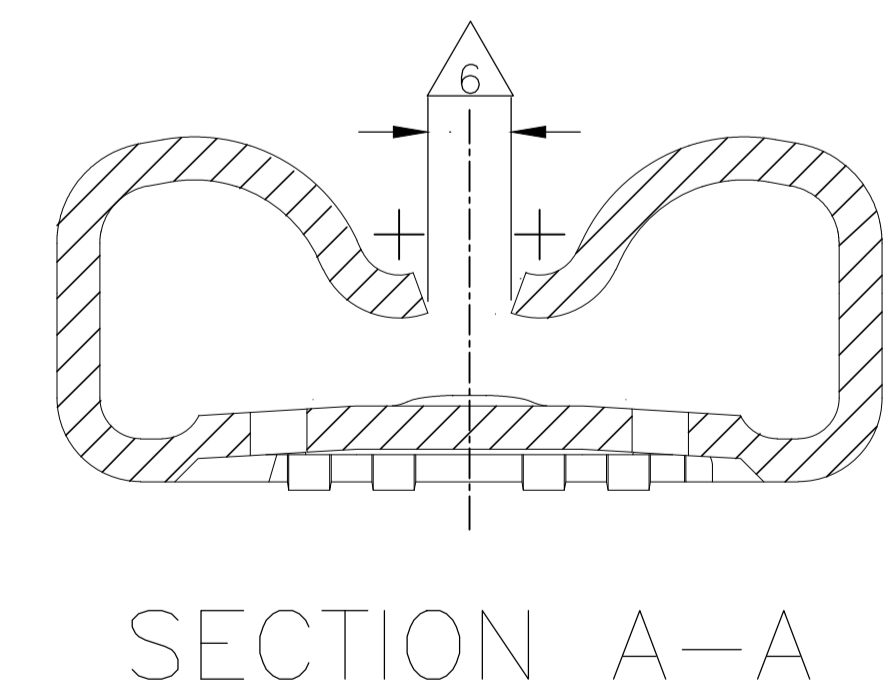
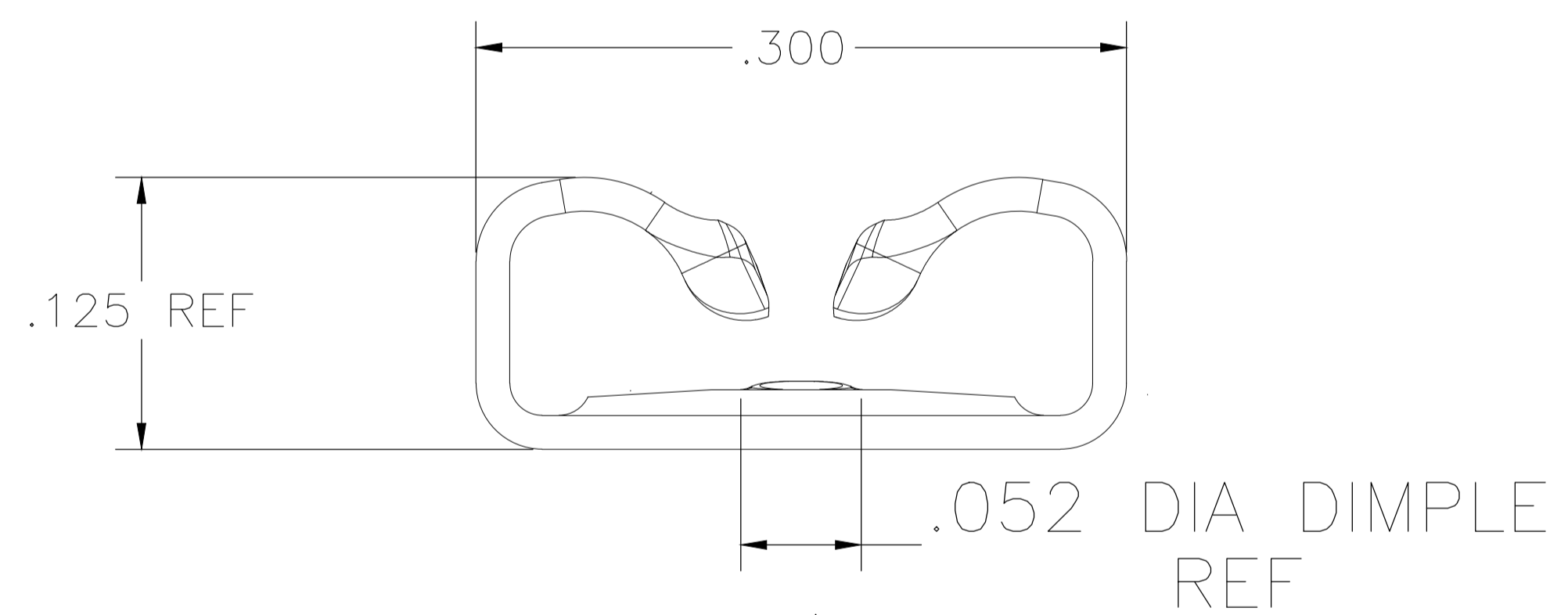
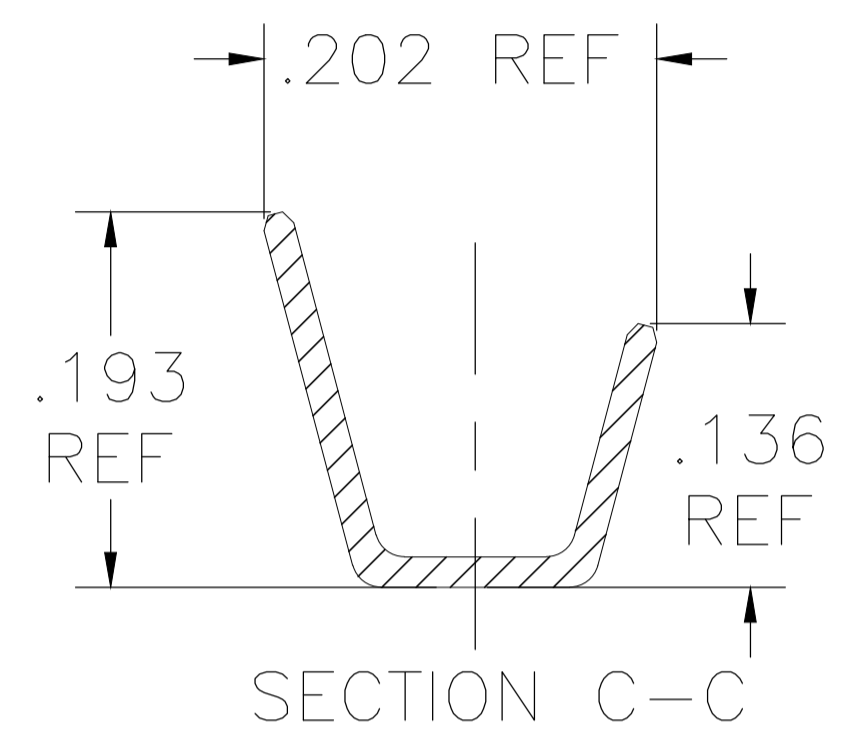
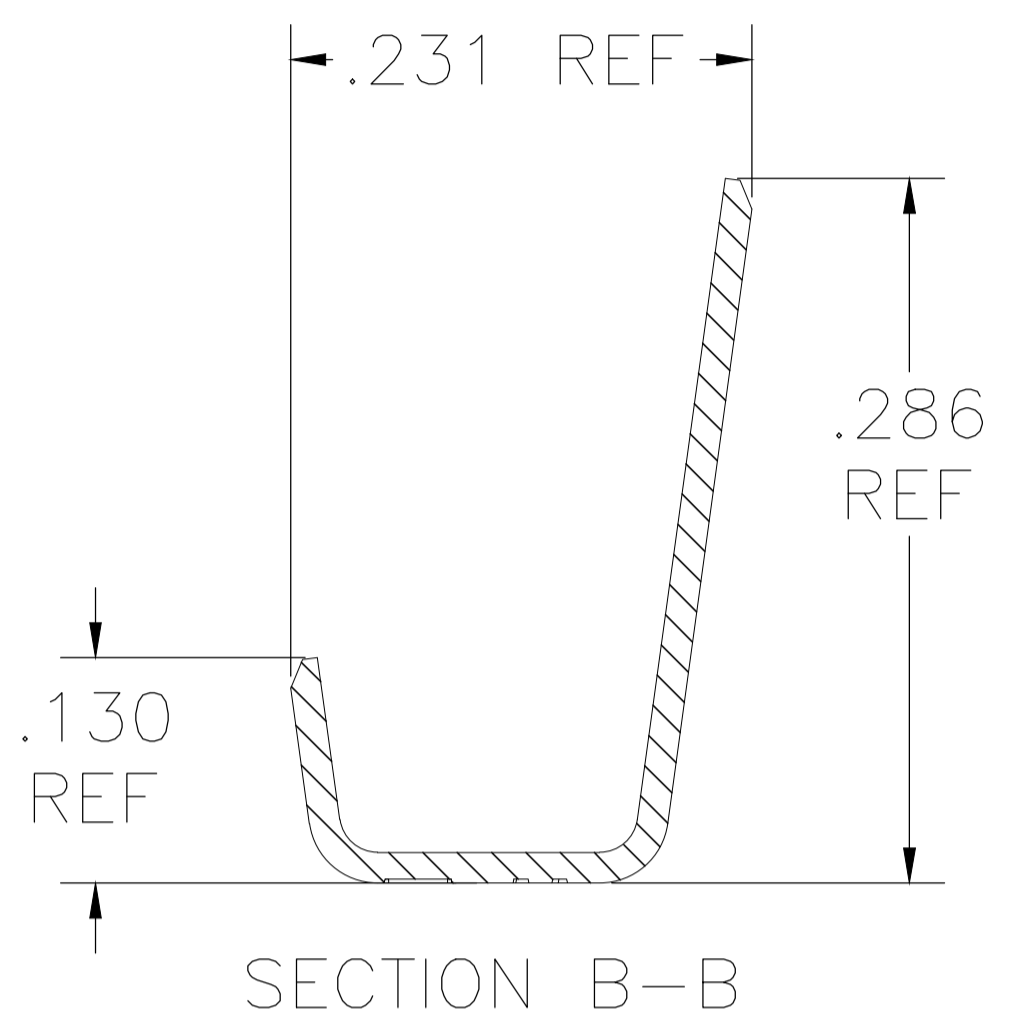
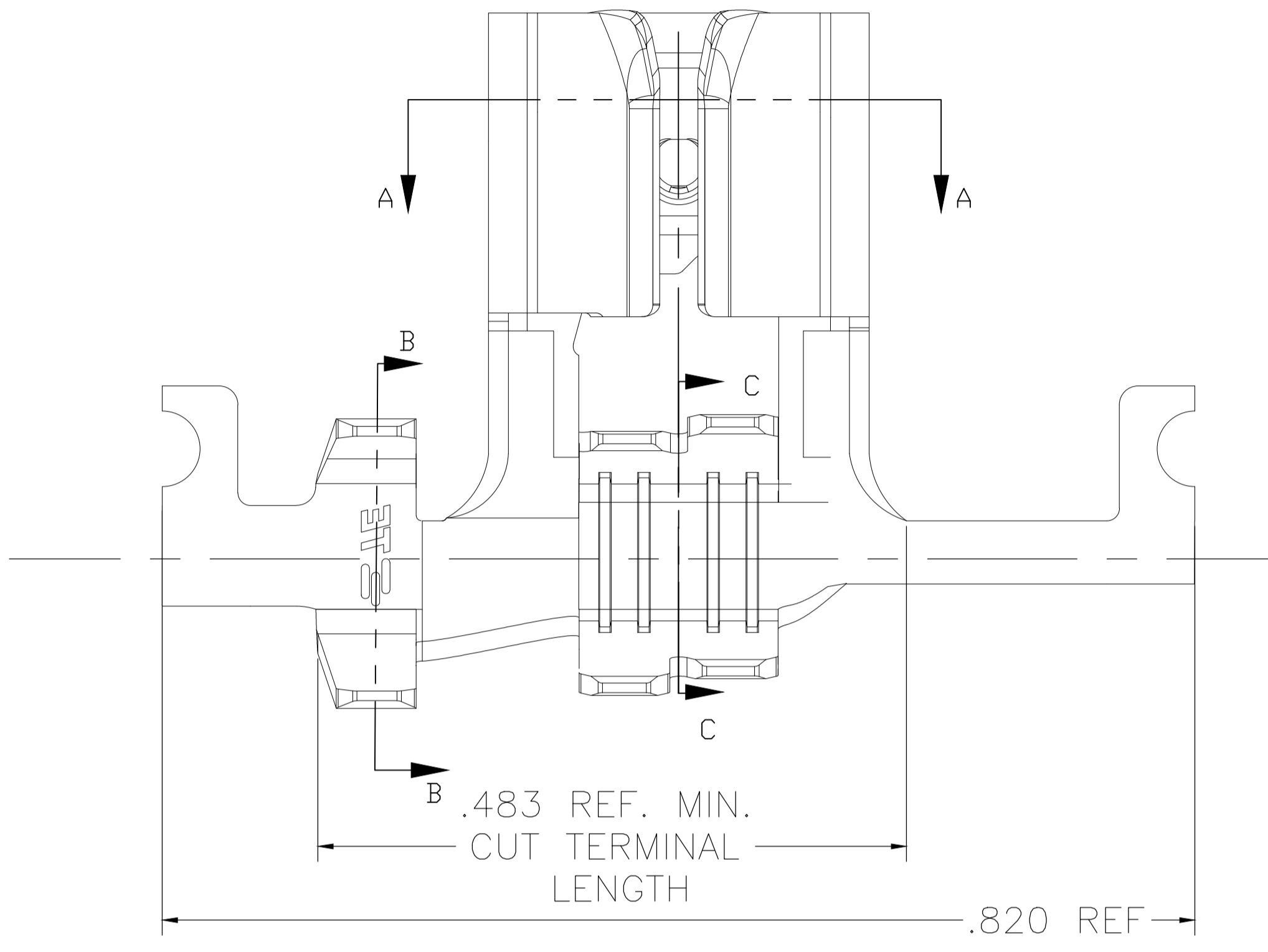

THIS DRAWING IS A CONTROLLED DOCUMENT.		TIN PLATED FINISH		BRASS MATERIAL		2238209-3 PART NUMBER	
DIMENSIONS: INCHES		TOLERANCES UNLESS OTHERWISE SPECIFIED:		DRAWING NO		RESTRICTED TO	
0 PLC ± -		1 PLC ± -		A1 00779		C=2238209	
2 PLC ± -		3 PLC ± .01		SCALE 10:1		SHEET 1 OF 1	
4 PLC ± -		ANGLES ± 1°		CUSTOMER DRAWING		REV A	