

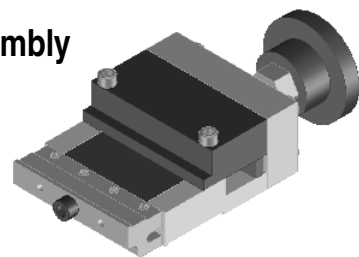

**EXTreme PowerMass™ Right Angle Plug Assembly
Stiffener Removal Tool
Instruction Sheet
Part No. 62202-3600**



FEATURES

% This tool is designed for removal and reinstallation of the top metal stiffener of a connector module.

SCOPE

Products: EXTreme PowerMass Right Angle Plug Assemblies (75555 series). See Product List below for specific part numbers.

Product List

The following is a partial list of the product order numbers and their specifications this tool is designed to run. Updates to this list are available on www.molex.com.

| Assembly Series No. And Description | Assembly Order No. | | | | | |
|--|--------------------|------------|------------|------------|------------|------------|
| 75555 Right Angle Plug Assemblies | 75555-1000 | 75555-1002 | 75555-1003 | 75555-1004 | 75555-1005 | 75555-1006 |
| | 75555-1007 | 75555-1008 | 75555-1009 | 75555-1010 | 75555-1021 | 75555-1025 |
| | 75555-1026 | 75555-1027 | 75555-1031 | 75555-1032 | | |
| | 75555-1100 | 75555-1102 | 75555-1108 | | | |

DESCRIPTION

The Stiffener Removal Tool consists of a slide that extends (to push the stiffener off the connectors) or retracts (to pull the stiffener onto the connectors). A series of pins engage the holes in the stiffener for removal. The press block drives the flat edge of the stiffener for reinstallation. See figure 1.

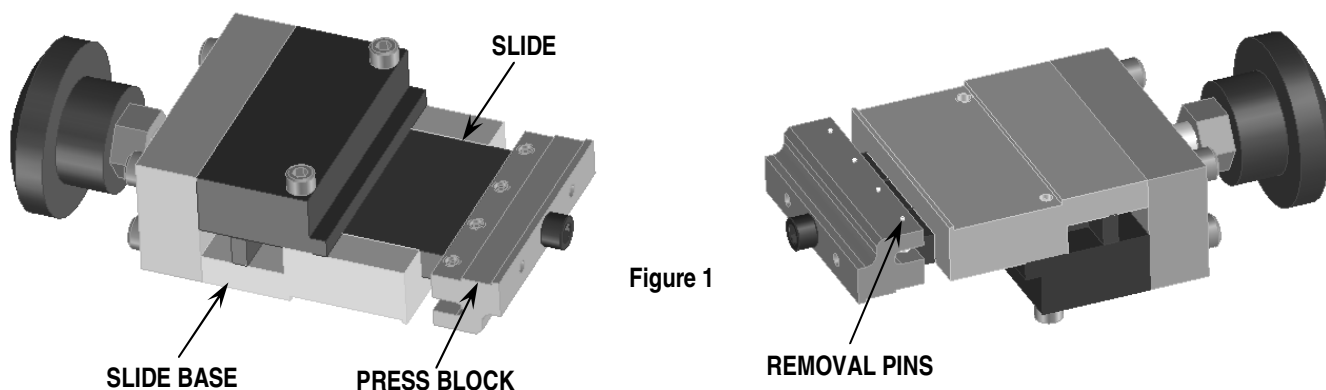
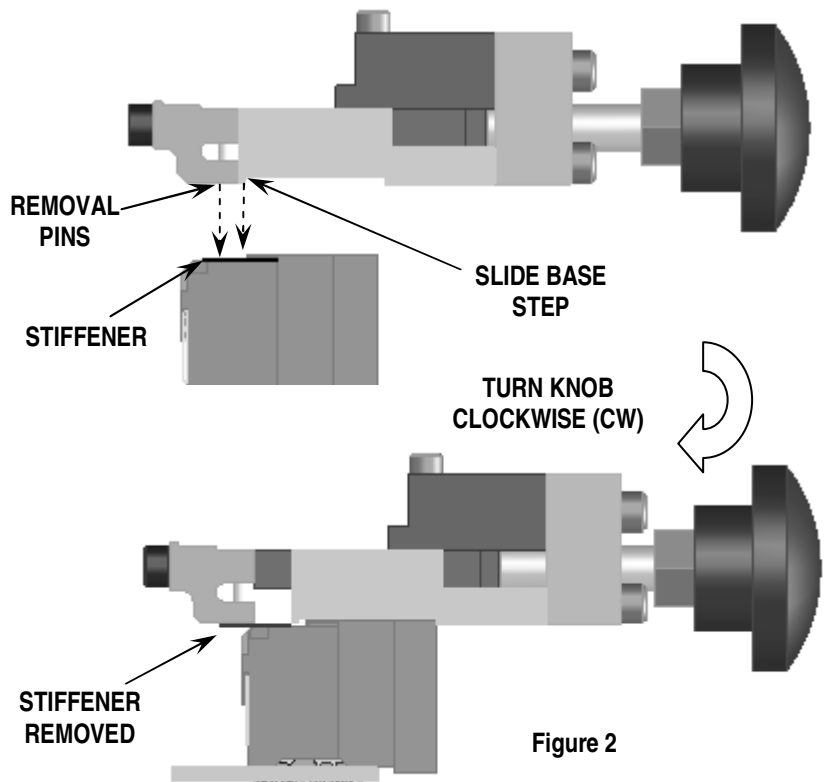

Figure 1

Metal Stiffener Removal

1. Place the tool's removal pins into the round holes of the metal stiffener. Align the step on the slide base with the step on the connectors.
2. Rotate the knob clockwise (CW) to position the step on the slide base so it will push against the connector housing. Continue turning the knob so the metal stiffener will be pushed off the connectors. See Figure 2.
3. For excessively long assemblies, it may be necessary to gradually remove the stiffener by moving the removal tool along the length of the assembly to avoid bending the stiffener.
4. The metal stiffener should now be free of the wafer modules and selected connector(s) can be replaced. The rear stiffener does not need to be removed to access the connectors.



Metal Stiffener Replacement

1. To do this, align the metal stiffener in the proper position with all individual modules. See Figure 3. Start the metal stiffener onto the modules by hand.

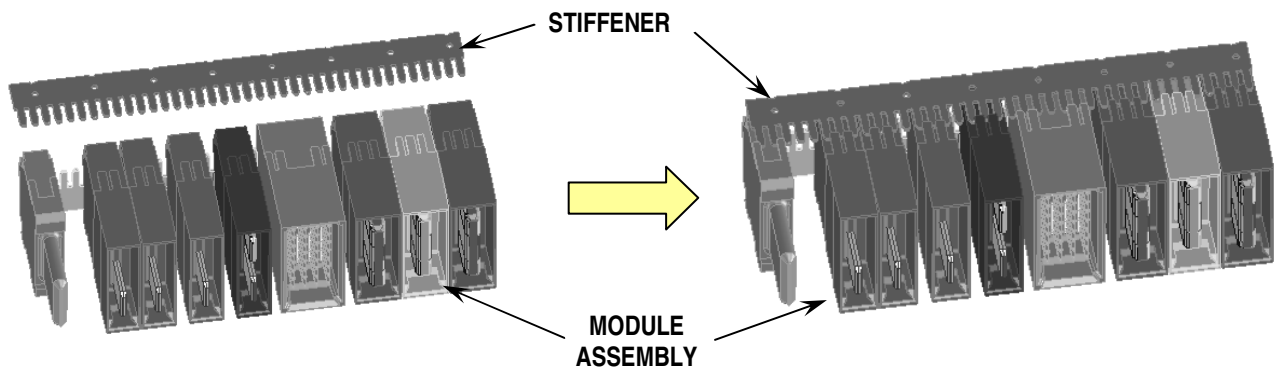

Figure 3

2. After the metal stiffener is positioned correctly on the module assembly, place the Stiffener Removal Tool on the connectors as shown in Figure 4. The installation of the metal stiffener does not use the removal pins.
3. Position the tool so it will fit over the connectors. Turn the knob in either direction allowing the tool to open or close enough so the module assembly fits between the press block and the stiffener locator. The stiffener locator should touch the straight edge of the metal stiffener. See Figure 4.
4. Turn the knob on the tool counter clockwise (CCW) so the stiffener locator moves toward the press block. See Figure 5. For excessively long assemblies it may be necessary to gradually install the stiffener by moving the tool along the length of the assembly.

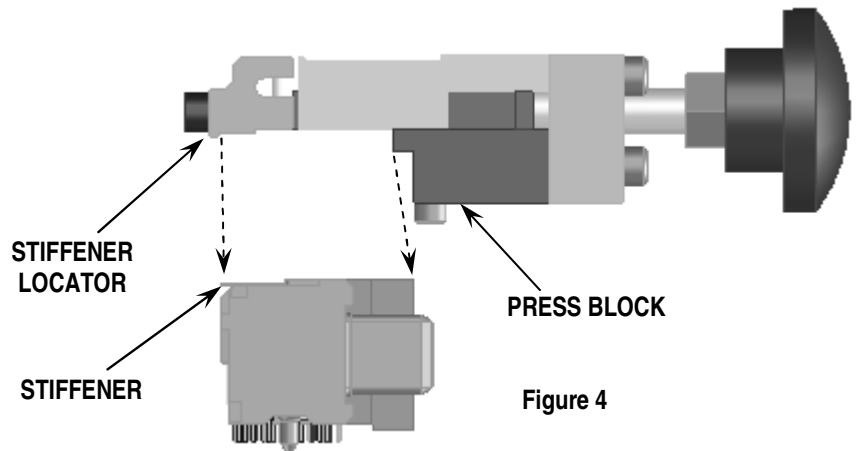

Figure 4

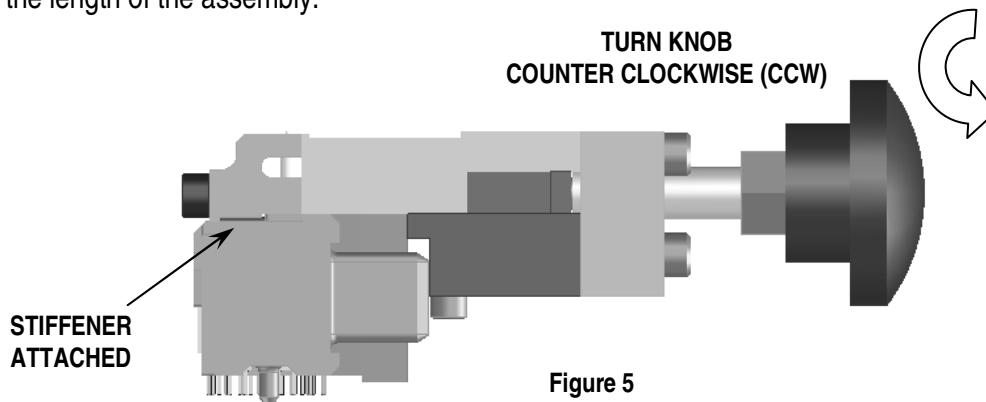

Figure 5

5. Do not turn the knob excessively. When the knob becomes difficult to turn, this is an indication that the stiffener is seated fully.

Maintenance

It is recommended that each operator of the tool be made aware of, and responsible for, the following maintenance steps:

1. Remove dust, moisture, and other contaminants with a clean brush, or soft, lint free cloth.
2. Do not use any abrasive materials that could damage the tool.
3. Make certain all pins; pivot points and bearing surfaces are protected with a thin coat of high quality machine oil. Do not oil excessively.
4. When tool is not in use, store in a clean, dry area.

CAUTION: Molex specifications are valid only when used with Molex connectors and tooling.

PARTS LIST

| Item | Order No | Description | Quantity |
|------|-------------------|---|-------------------|
| | 62202-3600 | EXTreme PowerMass Stiffener Removal Tool | (Figure 6) |
| 1 | 62201-6204 | Stop | 1 |
| 2 | 62202-2073 | Slide Base | 1 |
| 3 | 62202-2076 | Press Screw | 1 |
| 4 | 62202-2624 | Removal Pin | 4 |
| 5 | 62202-3621 | Stiffener Locator | 1 |
| 6 | 62202-3672 | Slide | 1 |
| 7 | 62202-3675 | Press Block | 1 |
| 8 | 63700-1936 | Knob, Plastic Fluted | 1 |
| 9 | N/A | 1/8" diameter by 1/2" long Dowel Pin | 2** |
| 10 | N/A | #8-32 by 0.75 long SHCS | 4** |
| 11 | N/A | #6-32 by 0.19 long Set Screw | 4** |
| 12 | N/A | 5/16-18 Hex Nut | 1** |
| 13 | N/A | #8-32 by 0.87 long SHCS | 1** |
| 14 | N/A | #6-32 by 3/4 long SHCS | 2** |

** Available from an industrial supply company such as MSC (1-800-645-7270).

Assembly Drawing

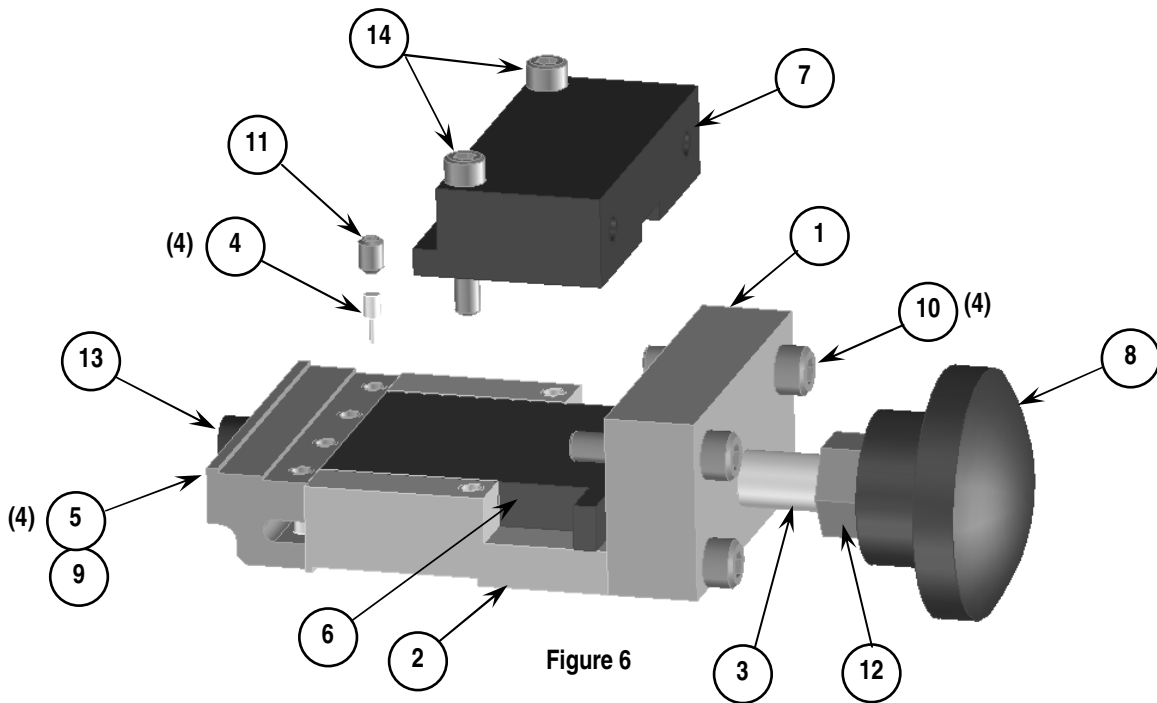

Figure 6

Americas Headquarters
 Lisle, Illinois 60532 U.S.A.
 1-800-78MOLEX
 amerinfo@molex.com

Far East North Headquarters
 Yamato, Kanagawa, Japan
 81-462-65-2324
 feninfo@molex.com

Far East South Headquarters
 Jurong, Singapore
 65-6-268-6868
 fesinfo@molex.com

European Headquarters
 Munich, Germany
 49-89-413092-0
 eurinfo@molex.com

Corporate Headquarters
 2222 Wellington Ct.
 Lisle, IL 60532 U.S.A.
 630-969-4550
 Fax: 630-969-1352

Visit our Web site at <http://www.molex.com>