

OV6922 NTSC product brief



Ultra Small 1/18-inch CMOS Camera-on-a-Chip



available in
a lead-free
package

The OV6922 is a 1/18-inch optical format CMOS image sensor incorporating a high level of functionality and very low power consumption in an ultra-small footprint package. This makes it ideal for use in small disposable cameras for medical imaging applications such as diagnostic and intubation systems.

The 2.1 mm x 2.3 mm CSP packaged sensor enables a microscopic camera module with a 4.0 mm diameter, to make medical procedures even less invasive for the patient.

Having been designed for very low power operation, the OV6922 only requires a clock and a single 3.3-volt DC power supply to get the NTSC composite signal out to a direct interface with a VCR and TV monitor.

The OV6922 is built on OmniVision's proprietary OmniPixel® architecture providing the highest image quality, performance and clarity. It is an ideal solution for medical applications that require both color video and a very small footprint package.

Find out more at www.ovt.com.



Applications

- Medical Devices
- Security and Surveillance
- Entertainment - Multimedia, Games and Toys

Product Features

- single chip 1/18" NTSC lens video camera
- composite video output
- automatic exposure/gain/white balance
- aperture correction
- gamma correction
- low power consumption
- +3.3V only power supply
- wide dynamic range, anti-blooming, zero smearing
- SCCB programmable controls:
 - color saturation
 - exposure
 - gain
 - gamma curve

OV6922

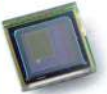

Ordering Information

- OV06922-V09N
(color, NTSC, lead-free, 9-pin CSP2)

Product Specifications

- active array size: 328 x 250
- power supply: 3.3 VDC ±5%
- power requirements (active):
 - without loading: 20 mA
 - with 75 ohm loading: 30 mA
- temperature range:
 - operating: -20°C to +70°C
 - stable image: 0°C to +50°C
- lens size: 1/18"
- electronic exposure: 1/60 s to 5.7 μs
- output formats: composite video
- color mosaic: RGB Bayer pattern
- sensitivity: 1000 mV/lux-sec
- max S/N ratio: 42 dB
- dynamic range: 66 dB @ 8x gain
- dark current: 3 mV/sec @ 60°C junction temperature
- pixel size: 2.5 μm x 2.5 μm
- image area: 820 μm x 625 μm
- package dimensions: 2135 μm x 2265 μm

Functional Block Diagram

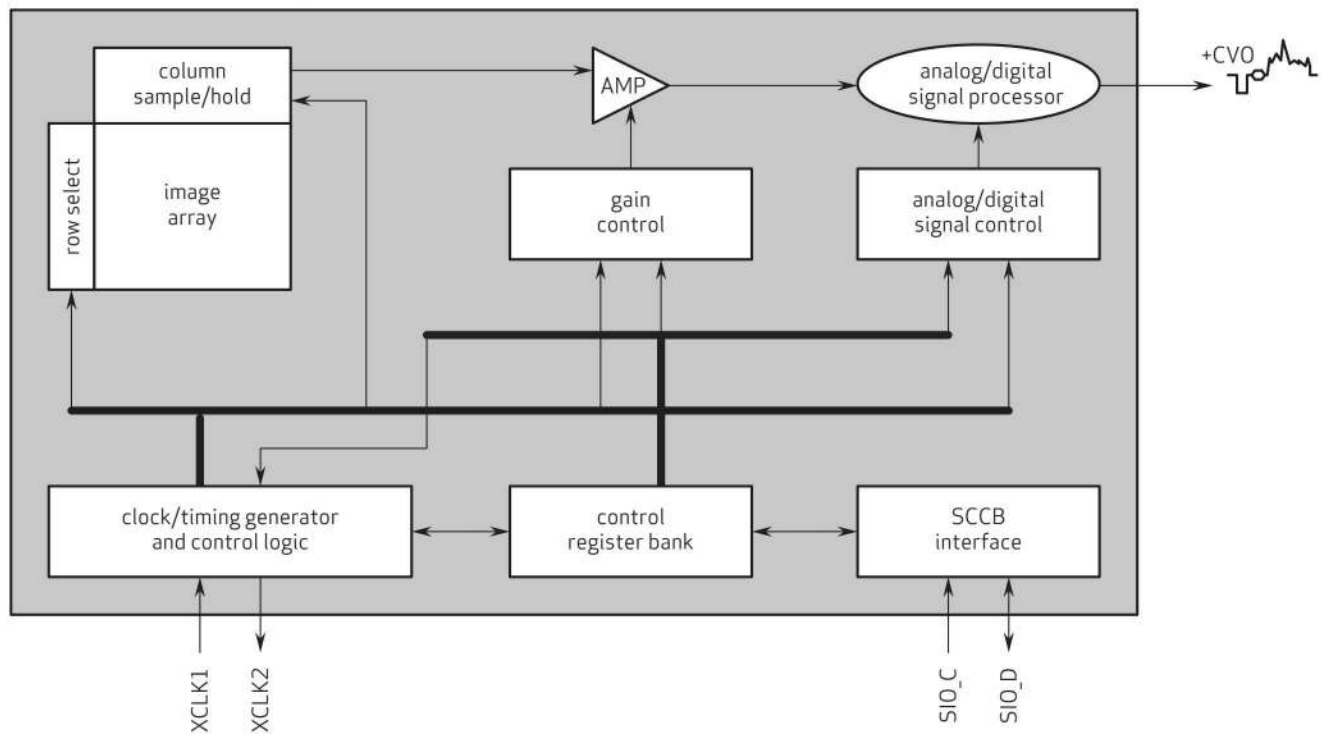

4275 Burton Drive
Santa Clara, CA 95054
USA

Tel: +1 408 567 3000
Fax: +1 408 567 3001
www.ovt.com

OmniVision reserves the right to make changes to their products or to discontinue any product or service without further notice. OmniVision, the OmniVision logo and OmniPixel are registered trademarks of OmniVision Technologies, Inc. OmniPixel2 is a trademark of OmniVision Technologies, Inc. All other trademarks are the property of their respective owners.



OmniVision