

FEATURES

- Product to be used with single or multiple external DDR SDRAM to provide significant storage capability of up to 1Gb density
- 166MHz operation (6ns read/write cycle time)
- User selectable input and output port bus-sizing
 - x36in to x36out
 - x36in to x18out
 - x36in to x9out
 - x18in to x36out
 - x18in to x18out
 - x18in to x9out
 - x9in to x36out
 - x9in to x18out
 - x9in to x9out
- For other bus configurations see IDT72T6480 (x12, x24, or x48)
- 2.5V-LVTTL or 3.3V-LVTTL configured ports
- Independent and simultaneous read and write access
- User selectable synchronous/asynchronous read and write port timing

- IDT Standard mode or FWFT mode of operation
- Empty and full flags for monitoring memory status
- Programmable Almost-Empty and Almost-Full flags, each flag can default to one of four preselected offsets or serially programmed to a specific value
- Selectable synchronous/asynchronous timing modes for Almost-Empty and Almost-Full flags
- Master Reset clears all data and settings
- Partial Reset clears data, but retains programmable settings
- Depth expandable with multiple devices for bus widths greater than 1Gb
- Width expandable with multiple devices for bus widths greater than 36 bits
- JTAG functionality (Boundary Scan)
- Available in a 324 pin FBGA (1mm pitch, 19mm x 19mm)
- HIGH performance 0.18µm CMOS technology
- Industrial temperature range (-40°C to +85°C) is available
- Supports industry standard DDR specifications, including Samsung, Micron, and Infineon memories

FUNCTIONAL BLOCK DIAGRAM

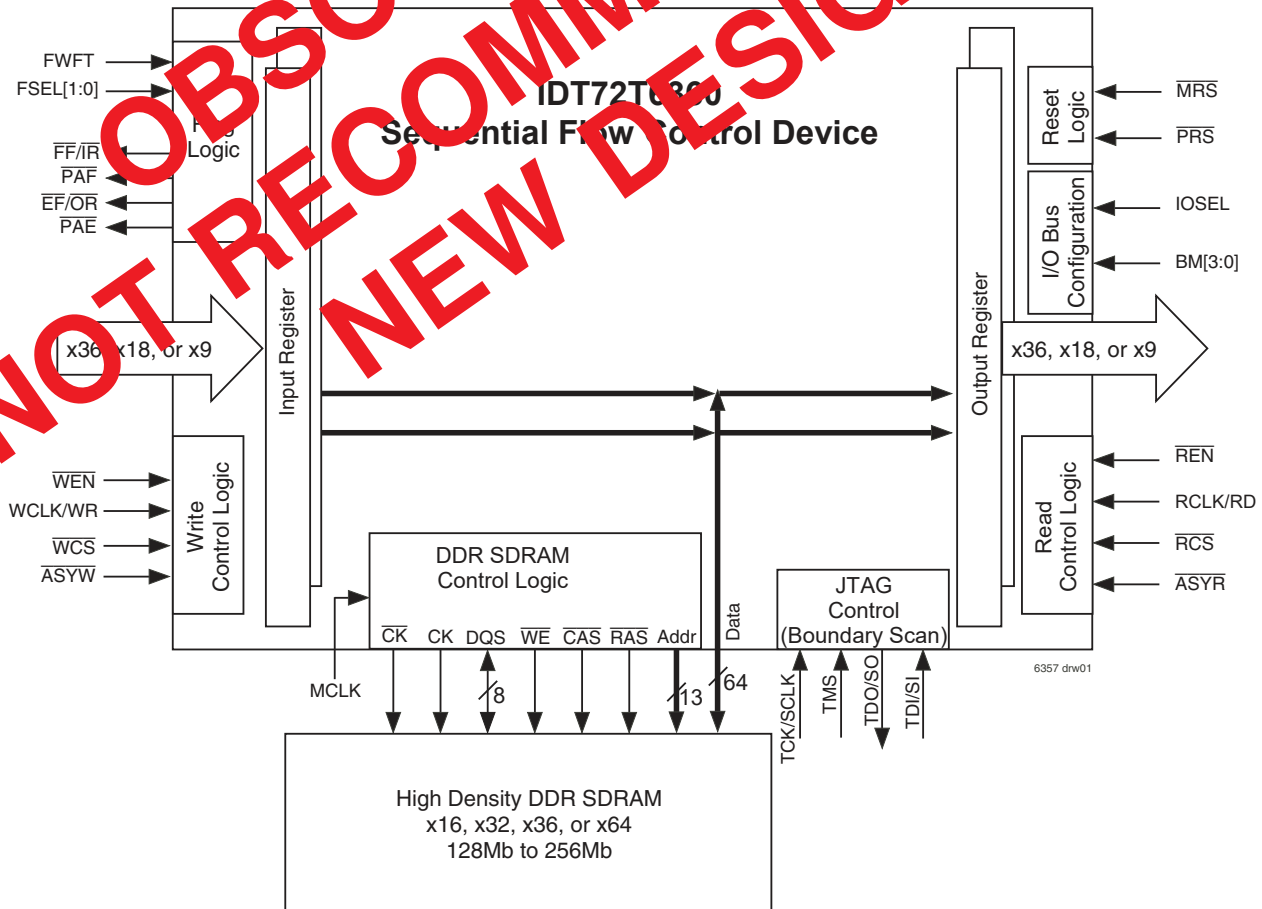

Table of Contents

Features	1
Description	4
Pin Configuration	6
Pin Descriptions	7-10
-Read Port Interface	7
-Write Port Interface	7
-Memory Interface	8
-Control and Feature Interface	8
-Power and Ground Signals	10
Detailed Descriptions	11
Functional Descriptions	22
Signal Descriptions	23
Device Characteristics	27
AC Test Conditions	29
AC Electrical Characteristics	30
JTAG Timing Specifications	45
Depth Expansion Configuration	49
Width Expansion Configuration	50

List of Tables

Table 1 – DDR SDRAM Minimum Specifications	11
Table 2 – Supported Memory Vendors	11
Table 3 – Total Possible External Memory Configurations	12
Table 4 – SFC to DDR SDRAM interface connections	14
Table 5 – Total useable memory based on various configurations	18
Table 6 – IDT72T6360 Maximum Frequency Based on 166MHz DDR SDRAM	19
Table 7 – IDT72T6360 Maximum Frequency Based on 133MHz DDR SDRAM	19
Table 8 – MIC[2:0] Configurations	20
Table 9 – Memory Configurations Settings	21
Table 10 – Device configuration	22
Table 12– Number of Bits Required for Offset Registers	22
Table 11– Default Programmable Flag Offsets	22
Table 13 – Bus-Matchings	24
Table 14 – MTYPE[1:0] Configurations	25
Table 15 – Parameters affected by I/O selection	25

List of Figures

Figure 1. Sequential Flow-Control Device Block Diagram	5
Figure 2a. Configuration 1 - Two Chip Solution	13
Figure 2b. Configuration 2 - Two Chip Solution	13
Figure 2c. Configuration 3 - Three Chip Solution	13
Figure 2d. Configuration 4 - Three Chip Solution	13
Figure 2e. Configuration 5 - Three Chip Solution	13
Figure 2f. Configuration 6 - Four Chip Solution	13
Figure 2g. Configuration 7 - Five Chip Solution	13
Figure 3. Memory Interface Connection (Single Chip)	17
Figure 4. Memory Interface Connection (Two Chip)	17
Figure 5a. AC Test Load	29
Figure 5b. Lumped Capacitive Load, Typical Derating	29
Figure 6. Master Reset and Initialization	32
Figure 7. Partial Reset	33
Figure 8. Write First Word Cycles - IDT Standard Mode	34
Figure 9. Write First Word Cycles - FWFT Mode	34
Figure 10. Empty Boundary - IDT Standard Mode	35
Figure 11. Empty Boundary - FWFT Mode	35
Figure 12. Full Boundary - IDT Standard Mode	36
Figure 13. Full Boundary - FWFT Mode	36
Figure 14. Output Enable	37
Figure 15. Read Chip Select	37
Figure 16. Write Chip Select	37
Figure 17. Bus-Matching Configuration - x36 In to x18 Out - IDT Standard Mode	38
Figure 18. Bus-Matching Configuration - x36 In to x9 Out - IDT Standard Mode	38
Figure 19. Bus-Matching Configuration - x18 In to x36 Out - IDT Standard Mode	39
Figure 20. Bus-Matching Configuration - x9 In to x36 Out - IDT Standard Mode	39
Figure 21. Synchronous PAE Flag - IDT Standard Mode and FWFT Mode	40
Figure 22. Synchronous PAF Flag - IDT Standard Mode and FWFT Mode	40
Figure 23. Asynchronous Read and PAF Flag - IDT Standard Mode	41
Figure 24. Asynchronous Write and PAE Flag - IDT Standard Mode	41
Figure 25. Asynchronous Write and PAF Flag - IDT Standard Mode	41
Figure 26. Asynchronous Empty Boundary - IDT Standard Mode	42
Figure 27. Asynchronous Full Boundary - IDT Standard Mode	42
Figure 28. Asynchronous Read and PAE Flag - IDT Standard Mode	42
Figure 29. Serial Loading of Programmable Flag Registers (IDT Standard and FWFT Modes)	43
Figure 30. Reading of Programmable Flag Registers (IDT Standard and FWFT Modes)	43
Figure 31. Standard JTAG Timing	44
Figure 32. JTAG Architecture	45
Figure 33. TAP Controller State Diagram	46
Figure 34. Depth Expansion Configuration in IDT Standard Mode	49
Figure 35. Depth Expansion Configuration in FWFT Mode	49
Figure 36. Width Expansion Configuration in IDT Standard Mode and FWFT Mode	50

DESCRIPTION

The IDT72T6360 sequential flow-control device is a device incorporating a seamless connection to external DDR SDRAM for significant storage capacity supporting high-speed applications. Both read and write ports of the sequential flow-control can operate independently at up to 166MHz. There is a user selectable correction feature that will correct any erroneous single data bit when reading from the SDRAM.

The independent read and write ports each has associated read and write clocks, enables, and chip selects. Both ports can operate either synchronously or asynchronously. Other features include bus-matching, programmable status flags with selectable synchronous/asynchronous timing modes, IDT Standard or FWFT mode timing, and JTAG boundary scan functionality.

The bus-matching feature will allow the inputs and outputs to be configured to x36, x18, or x9 bus width. There are four default offset values available

for the programmable flags ($\overline{PAE}/\overline{PAF}$), as well as the option of serially programming the offsets to a specific value.

The device package is 19mm x 19mm 324-pin PBGA. It operates at a 2.5V core voltage with selectable 2.5V or 3.3V I/Os. The I/O interface to the SDRAM will be 2.5V SSTL_2 only and not 3.3V tolerant. Both industrial and commercial temperature ranges will be offered.

The sequential flow-control device controls individual DDR SDRAM of either 128Mb or 256Mb. The device will support industry standard DDR specification memories (note DDR II is not supported), which include vendors such as Samsung, Micron, and Infineon. The data bus connected to the DDR SDRAM can be 16-bit, 32-bit, or 64-bits wide. The sequential flow-control device can independently control up to four separate external memories for a maximum of density of 1Gb (128MB). Depth expansion mode is available for applications that require more than 1Gb of storage memory.

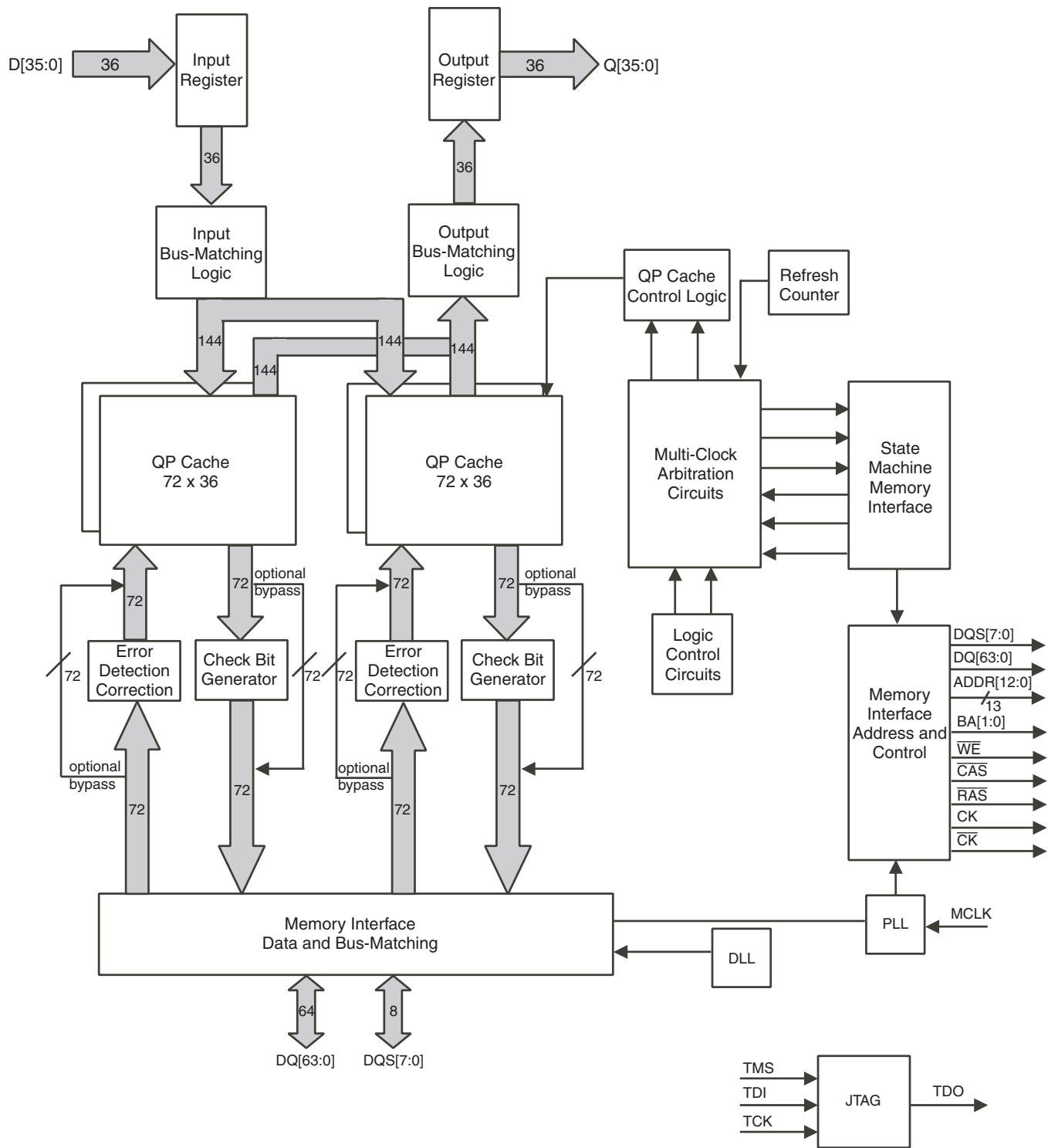

6357 drw02

Figure 1. Sequential Flow-Control Device Block Diagram

PIN CONFIGURATION

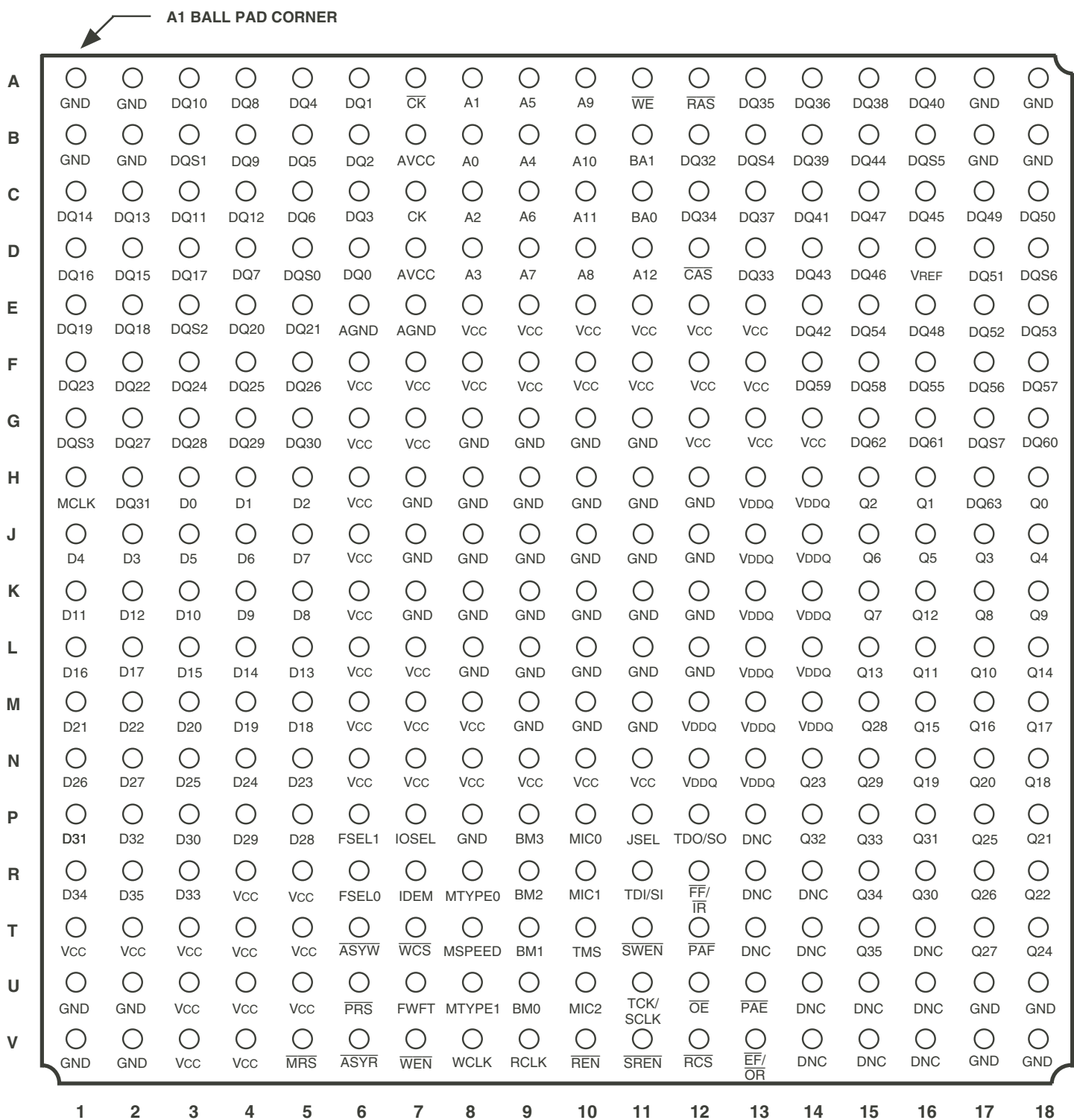

6357 drw03

NOTE:

1. DNC = Do Not Connect.

PBGA (BB324-1, order code: BB)
TOP VIEW

PIN DESCRIPTIONS

Symbol	Pin No. Location	Name	I/O TYPE	Description
<i>READ PORT INTERFACE</i>				
ASYR ⁽¹⁾	V6	Asynchronous Read Port	INPUT 3.3V or 2.5V LVTTTL	A HIGH on this input during master reset will select synchronous read operation for the output port. A LOW will select asynchronous operation. If asynchronous is selected the device must operate in IDT Standard mode and the read enable must be tied to GND.
$\overline{EF}/\overline{OR}$	V13	Empty Flag/ Output Ready	OUTPUT 3.3V or 2.5V LVTTTL	In IDT Standard mode, the \overline{EF} function is selected. \overline{EF} indicates whether or not the device memory is empty. In FWFT mode, the \overline{OR} function is selected. \overline{OR} indicates whether or not there is valid data available at the outputs.
\overline{OE}	U12	Output Enable	INPUT 3.3V or 2.5V LVTTTL	Asynchronous three-state control of the data outputs. All data outputs Q[35:0] will be placed in high-impedance if this pin is HIGH. Conversely, all data outputs will be active when this pin is LOW.
\overline{PAE}	U13	Programmable Almost Empty Flag	OUTPUT 3.3V or 2.5V LVTTTL	This is the programmable almost empty flag that can be used as an early indicator for the empty boundary condition of the internal memory. \overline{PAE} goes LOW if the number of words in the sequential flow-control device is less than offset n, which is stored in the empty offset register. \overline{PAE} goes HIGH if the number of words in the sequential flow-control device is greater than or equal to the offset n.
Q[35:0]	See Pin No. table	Data Output Bus	OUTPUT 3.3V or 2.5V LVTTTL	Data outputs for a 36, 18, and 9-bit bus.
RCLK/ RD	V9	Read Clock/ Read Strobe	INPUT 3.3V or 2.5V LVTTTL	This is a dual function pin. If synchronous operation of the read port is selected, the rising edge of RCLK reads data from the sequential flow-control device when \overline{REN} is enabled. If asynchronous operation of the read port is selected, a rising edge on RD reads data from the sequential flow-control device without the need of a free-running input read clock.
\overline{RCS}	V12	Read Chip Select	INPUT 3.3V or 2.5V LVTTTL	Synchronous three-state control of the data outputs. Provides another means of controlling the data outputs synchronous to RCLK. Can be regarded as a second output enable signal.
\overline{REN}	V10	Read Enable	INPUT 3.3V or 2.5V LVTTTL	\overline{REN} enables RCLK for reading data from the sequential flow-control device. If asynchronous mode is selected on the read port, this signal should be tied to GND.
\overline{SREN}	V11	Serial Read Enable	INPUT 3.3V or 2.5V LVTTTL	When \overline{SREN} is brought LOW before the rising edge of SCLK, the contents of the \overline{PAE} and \overline{PAF} offset registers are copied to a serial shift register. While \overline{SREN} is maintained LOW, on each rising edge of SCLK, one bit of data is shifted out of this serial shift register through the SO output pin used only when JSEL = 0.
<i>WRITE PORT INTERFACE</i>				
ASYW ⁽¹⁾	T6	Asynchronous Write Port	INPUT 3.3V or 2.5V LVTTTL	A HIGH on this input during master reset will select synchronous write operation for the input port. A LOW will select asynchronous operation. If asynchronous is selected the device must operate in IDT Standard mode and the write enable must be tied to GND.
D[35:0]	See Pin No. table	Data Inputs	INPUT 3.3V or 2.5V LVTTTL	Data inputs for a 36, 18, and 9-bit bus.
$\overline{FF}/\overline{IR}$	R12	Full Flag/ Input Ready	OUTPUT 3.3V or 2.5V LVTTTL	In IDT Standard mode, the \overline{FF} function is selected. \overline{FF} indicates whether or not the device memory is full. In FWFT mode, the \overline{IR} function is selected. \overline{IR} indicates whether or not there is space available for writing to the device memory.
\overline{PAF}	T12	Programmable Almost Full Flag	OUTPUT 3.3V or 2.5V LVTTTL	This is the programmable almost full flag that can be used as an early indicator for the full boundary condition of the internal memory. \overline{PAF} goes HIGH if the number of free locations in the sequential flow-control device is more than offset m, which is stored in the full offset register. \overline{PAF} goes LOW if the number of free locations in the sequential flow-control device is less than or equal to the offset m.
\overline{SWEN}	T11	Serial Write Enable	INPUT 3.3V or 2.5V LVTTTL	On each rising edge of SCLK when \overline{SWEN} is LOW, data from the SI pin is serially loaded into the \overline{PAE} and \overline{PAF} registers used only when JSEL = 0.

PIN DESCRIPTIONS (Continued)

Symbol	Pin No. Location	Name	I/O TYPE	Description
<i>WRITE PORT INTERFACE (Continued)</i>				
WCLK/WR	V8	Write Clock/ Write Strobe	INPUT 3.3V or 2.5V LVTTTL	This is a dual function pin. If synchronous operation of the write port is selected, the rising edge of WCLK writes data into the sequential flow-control device when \overline{WEN} is enabled. If asynchronous operation of the write port is selected, a rising edge on WR writes data into the sequential flow-control device without the need of a free-running input write clock.
\overline{WCS}	T7	Write Chip Select	INPUT 3.3V or 2.5V LVTTTL	Synchronous three-state control of the data inputs. Provides a means of controlling the data inputs synchronous to WCLK. Typically used to avoid bus-contention when multiple devices are sharing the same input data bus.
\overline{WEN}	V7	Write Enable	INPUT 3.3V or 2.5V LVTTTL	\overline{WEN} enables WCLK for writing data into the sequential flow-control device. If asynchronous mode is selected on the write port, this signal should be tied to GND.
<i>MEMORY INTERFACE</i>				
A[12:0]	See Pin No. table	Memory Address Bus	OUTPUT SSTL_2	Output address bus to be connected to the input address bus of the external memory to provide row and column address.
BA[1:0]	BA1-B11 BA0-C11	Memory Bank Address Input Bit	OUTPUT SSTL_2	Address bits to be connected to the external memory's BA inputs to determine which bank an ACTIVE, READ, WRITE, or PRECHARGE command is being applied.
CK	C7	Memory Clock	OUTPUT SSTL_2	Clock output to be connected to the external memory's input clock.
\overline{CK}	A7	Memory Clock Inverted	OUTPUT SSTL_2	Differential clock output to be connected to the external memory's differential input clock.
\overline{CAS}	D12	Memory Column Address Strobe	OUTPUT SSTL_2	Output enable signal to be connected to the external memory's \overline{CAS} pin to activate and deactivate the column address strobe.
DQ[63:0]	See Pin No. table	Memory Data Bus	Bi-Directional SSTL_2	Input/output data bus for the external memory's data bus.
DQS[7:0]	See Pin No. table	Memory Data Strobe	Bi-Directional SSTL_2	Input/output data strobe to be connected to the external memory's data strobe.
\overline{RAS}	A12	Memory Row Address Strobe	OUTPUT SSTL_2	Output strobe signal to be connected to the external memory's \overline{RAS} pin to activate and deactivate the row address strobe.
\overline{WE}	A11	Memory Write Enable	OUTPUT SSTL_2	Output strobe signal to be connected to the external memory's \overline{WE} pin to activate and deactivate the write address strobe.
<i>CONTROL AND FEATURE INTERFACE</i>				
BM[3:0] ⁽¹⁾	See Pin No. table	Bus-Matching Bit	INPUT 3.3V or 2.5V LVTTTL	Selects the bus width of the read and write ports.
FSEL[1:0] ⁽¹⁾	FSEL1-P6 FSEL0-R6	Flag Select Bit	INPUT 3.3V or 2.5V LVTTTL	During master reset, these inputs will select one of four default values for the programmable flags PAE and PAF. The selected value will apply to both PAE and PAF offset.
FWFT ⁽¹⁾	U7	First Word Fall Through	INPUT 3.3V or 2.5V LVTTTL	During master reset, a HIGH on this input selects FWFT timing mode. A LOW selects IDT Standard timing mode.
IDEM ⁽¹⁾	R7	IDT Standard Mode Depth Expansion Mode Select	INPUT 3.3V or 2.5V LVTTTL	This select pin is used for depth expansion configuration in IDT Standard mode. If this pin is tied HIGH, then the $\overline{FF}/\overline{IR}$ signal will be inverted to provide a seamless depth expansion interface. If depth expansion in FWFT mode is desired, this pin should be tied to GND. If no depth expansion is used, this pin should be tied to GND.
IOSEL ⁽¹⁾	P7	I/O VDDQ Select	INPUT 3.3V or 2.5V LVTTTL	This input determines whether the inputs and outputs will tolerate a 2.5V or 3.3V voltage signals. If IOSEL is HIGH, then all I/Os will be 2.5V tolerant. If IOSEL is LOW, then all I/Os will be 3.3V tolerant. See table 15, for a list of affected I/O signals.

PIN DESCRIPTIONS (Continued)

Symbol	Pin No. Location	Name	I/O TYPE	Description
<i>CONTROL AND FEATURE INTERFACE (Continued)</i>				
JSEL ⁽¹⁾	P11	JTAG Select	INPUT 3.3V or 2.5V LVTTTL	This pin selects whether the JTAG pins will be used for serial programming. If JSEL is HIGH, the JTAG pins will only be used for JTAG boundary-scan function. If JSEL is LOW, the JTAG function is disabled and the JTAG pins will be used for serial programming of the $\overline{\text{PAE}}/\overline{\text{PAF}}$ offset registers.
MIC[2:0] ⁽¹⁾	MIC2-U10 MIC1-R10 MIC0-P10	Memory Configuration	INPUT 3.3V or 2.5V LVTTTL	These signals enable the EDC feature of the device. See Table 8, MIC[2:0] Configurations for details.
MCLK	H1	Master Clock	INPUT 3.3V or 2.5V LVTTTL	33MHz reference clock used to generate CK and $\overline{\text{CK}}$ for external memory interface.
$\overline{\text{MRS}}$	V5	Master Reset	INPUT 3.3V or 2.5V LVTTTL	Master reset initializes the read and write pointers to zero and sets the output register to all zeros. All initialized settings for the device will be configured during master reset.
MSPEED ⁽¹⁾	T8	Memory Speed	INPUT 3.3V or 2.5V LVTTTL	This input select the speed of the external memory interfacing the sequential flow-control device. A LOW selects 133MHz, and HIGH selects 166MHz.
MTYPE ⁽¹⁾ [1:0]	MTYPE1-U8 MTYPE0-R8	Memory Type [1:0]	INPUT 3.3V or 2.5V LVTTTL	These inputs select which type of external memory is interfacing the sequential flow-control device. See Table 14 for the list of selectable memories.
$\overline{\text{PRS}}$	U6	Partial Reset	INPUT 3.3V or 2.5V LVTTTL	Partial reset initializes the read and write pointers to zero and sets the output registers to all zeros. All existing configurations in the sequential flow-control device will not be affected. This includes the IDT Standard or FWFT mode timing, programmable flag settings, and bus width and data rate mode.
TCK/ SCLK	U11	JTAG Clock/ Serial Clock	INPUT 3.3V or 2.5V LVTTTL	This is a dual function pin. When the JSEL pin is HIGH, this is the clock input for JTAG boundary-scan function. One of four terminals required by IEEE Standard 1149.1-1990. Test operations of the device are synchronous to TCK. Data from TMS and TDI are sampled on the rising edge of TCK and outputs change on the falling edge of TCK. When the JSEL pin is LOW, this is the serial clock input for writing and reading the $\overline{\text{PAE}}/\overline{\text{PAF}}$ offset registers. On the rising edge of every SCLK when $\overline{\text{SWEN}}$ is LOW, one bit of data from the SI pin is shifted into the $\overline{\text{PAE}}$ and $\overline{\text{PAF}}$ offset registers. On the rising edge of each SCLK when SREN is LOW, one bit of data from the SO pin is shifted out of the $\overline{\text{PAE}}$ and $\overline{\text{PAF}}$ offset registers. If the JTAG or serial programming is not used this signal needs to be tied to GND.
TDI/SI	R11	JTAG Test Data Input/ Serial Input	INPUT 3.3V or 2.5V LVTTTL	This is a dual function pin. When the JSEL pin is HIGH, this is the JTAG test data input pin. One of four terminals required by IEEE Standard 1149.1-1990. During the JTAG boundary scan operation, test data serially loaded via the TDI on the rising edge of TCK to the Instruction Register, ID Register and Bypass Register. When the JSEL pin is LOW, this is the serial input pin for the $\overline{\text{PAE}}/\overline{\text{PAF}}$ offset registers. An internal pull-up resistor forces TDI/SI HIGH if left unconnected.
TDO/SO	P12	JTAG Test Data Output/Serial Output	OUTPUT 3.3V or 2.5V LVTTTL	This is a dual function pin. When the JSEL pin is HIGH, this is the JTAG test data output pin. One of four terminals required by IEEE Standard 1149.1-1990. During the JTAG boundary scan operation, test data serially loaded output via the TDO on the falling edge of TCK from either the Instruction Register, ID Register and Bypass Register. This output is high-impedance except when shifting, while in SHIFT-DR and SHIFT-IR controller states. When the JSEL pin is LOW, this is the serial data output pin for the $\overline{\text{PAE}}/\overline{\text{PAF}}$ offset registers.
TMS	T10	JTAG Mode Select	INPUT 3.3V or 2.5V LVTTTL	TMS is a serial input pin. One of four terminals required by IEEE Standard 1149.1-1990. TMS directs the device through its TAP controller states. An internal pull-up resistor forces TMS HIGH if left unconnected.

NOTE: 1. These pins should not change after master reset.

Please see next page for Power & Ground pins and Pin Number Location Table.

PIN DESCRIPTIONS (Continued)

Symbol	Pin No. Location	Name	I/O TYPE	Description
POWER AND GROUND SIGNALS				
Vcc	See Pin No. table	Core Vcc and Output voltage for DDR SDRAM	Power	The core power supply pins for the device as well as to the external DDR SDRAM. Needs to be connected to a +2.5V Vcc power plane.
AVcc	B7, D7	Internal PLL Vcc	Power	The power supply pins for the internal PLL of the device. Needs to be connected to a +2.5V supply rail.
VDDQ	See Pin No. table	Output rail voltage for I/Os	Power	This pin is used to provide power to the output drivers. The nominal values are 2.5V or 3.3V, depending on the state of the IOSEL pin.
VREF	D16	Reference Voltage	Power	This is a voltage reference input to the SDRAM and must be connected to Vcc/2.
GND	See Pin table	Ground Pin	Ground	The ground pins for the device that must be connected to the ground plane.
AGND	E6, E7	Ground pin for analog circuit	Ground	The ground pins for the analog circuitry in the device that must be connected to the ground plane.

PIN NUMBER LOCATION TABLE

Symbol	Name	I/O TYPE	Pin Number
A[12:0]	Memory Address Bus	OUTPUT SSTL_2	A12-D11, A11-C10, A10-B10, A9-A10, A8-D10, A7-D9, A6-C9, A5-A9, A4-B9, A3-D8, A2-C8, A1-A8, A0-B8
BM[3:0]	Bus-Matching	INPUT 3.3V or 2.5V LVTTTL	BM3-P9, BM2-R9, BM1-T9, BM0-U9
D[35:0]	Data Inputs	INPUT 3.3V or 2.5V LVTTTL	D35-R2, D34-R1, D33-R3, D32-P2, D31-P1, D30-P3, D29-P4, D28-P5, D27-N2, D26-N1, D25-N3, D24-N4, D23-N5, D22-M2, D21-M1, D20-M3, D19-M4, D18-M5, D17-L2, D16-L1, D15-L3, D14-L4, D13-L5, D12-K2, D11-K1, D10-K3, D9-K4, D8-K5, D7-J5, D6-J4, D5-J3, D4-J1, D3-J2, D2-H5, D1-H4, D0-H3
DQ[63:0]	Memory Data Bus	Bi-Directional SSTL_2	DQ63-H17, DQ62-G15, DQ61-G16, DQ60-G18, DQ59-F14, DQ58-F15, DQ57-F18, DQ56-F17, DQ55-F16, DQ54-E15, DQ53-E18, DQ52-E17, DQ51-D17, DQ50-C18, DQ49-C17, DQ48-E16, DQ47-C15, DQ46-D15, DQ45-C16, DQ44-B15, DQ43-D14, DQ42-E14, DQ41-C14, DQ40-A16, DQ39-B14, DQ38-A15, DQ37-C13, DQ36-A14, DQ35-A13, DQ34-C12, DQ33-D13, DQ32-B12, DQ31-H2, DQ30-G5, DQ29-G4, DQ28-G3, DQ27-G2, DQ26-F5, DQ25-F4, DQ24-F3, DQ23-F1, DQ22-F2, DQ21-E5, DQ20-E4, DQ19-E1, DQ18-E2, DQ17-D3, DQ16-D1, DQ15-D2, DQ14-C1, DQ13-C2, DQ12-C4, DQ11-C3, DQ10-A3, DQ9-B4, DQ8-A4, DQ7-D4, DQ6-C5, DQ5-B5, DQ4-A5, DQ3-C6, DQ2-B6, DQ1-A6, DQ0-D6,
DQS[7:0]	Memory Data Strobe	Bi-Directional SSTL_2	DQS7-G17, DQS6-D18, DQS5-B16, DQS4-B13, DQS3-G1, DQS2-E3, DQS1-B3, DQS0-D5
Q[35:0]	Data Output Bus	Output 3.3V or 2.5V LVTTTL	Q35-T15, Q34-R15, Q33-P15, Q32-P14, Q31-P16, Q30-R16, Q29-N15, Q28-M15, Q27-T17, Q26-R17, Q25-P17, Q24-T18, Q23-N14, Q22-R18, Q21-P18, Q20-N17, Q19-N16, Q18-N18, Q17-M18, Q16-M17, Q15-M16, Q14-L18, Q13-L15, Q12-K16, Q11-L16, Q10-L17, Q9-K18, Q8-K17, Q7-K15, Q6-J15, Q5-J16, Q4-J18, Q3-J17, Q2-H15, Q1-H16, Q0-H18
Vcc	Core Vcc & Output voltage for DDR SDRAM	Power	E(8-13), F(6-13), G(6,7,12-14), H6, J6, K6, L(6,7), M(6-8), N(6-11), R(4,5), T(1-5), U(3-5), V(3,4)
VDDQ	Output rail voltage for I/Os	Power	H(13,14), J(13,14), K(13,14), L(13,14), M(12-14), N(12,13)
GND	Ground Pin	Ground	A(1,2,17,18), B(1,2,17,18), G(8-11), H(7-12), J(7-12), K(7-12), L(8-12), M(9-11), P8, U(1,2,17,18), V(1,2,17,18)
DNC	Do Not Connect	—	P13, R(13,14), T(13,14,16), U(14-16), V(14-16)

DETAILED DESCRIPTIONS

SEQUENTIAL FLOW-CONTROL STRUCTURE

The IDT sequential flow-control (SFC) device is comprised of three interfaces: input port, output port, and memory interface. The input and output port can operate independently of each other with selectable bus widths of x9, x18, or x36 bits wide. The third interface, or memory interface, is connected directly to an external memory, which can be used to offload data entering the SFC device.

WRITING AND READING FROM THE SEQUENTIAL FLOW-CONTROL DEVICE

Writing into the SFC device is accomplished by setting the write enable signal (\overline{WEN}) and write chip select (\overline{WCS}) low with a free running write clock (WCLK). Data will be written on the rising edge of every WCLK into the Quad-Port (QP) cache of the SFC device. The internal state machine of the device will determine whether to send the data to the DDR SDRAM or send it directly through to the output bus, depending on when the data is to be accessed. This provides "data coherency" and minimizes the path that the data has to travel.

Reading from the SFC device is accomplished by setting the read enable signal (\overline{REN}) and read chip select (\overline{RCS}) low with a free running read clock (RCLK). Data will be sent to the output bus on the rising edge of every RCLK. This data will be accessed either from the QP cache or the external DDR SDRAM.

EXTERNAL MEMORY SELECTION

The DDR SDRAM interface of the SFC device can support DDR SDRAM with standard DDR I specifications. The SFC device can support any external memory within the following characteristics:

- Bus width: 16-bit or 32-bit wide
- Speed: 133MHz or 166MHz
- Density: 128Mb or 256Mb

Table 1 lists the DDR SDRAM minimum specifications that are required to meet the sequential flow-control device requirements. Table 2 lists the memory vendors and associated part numbers of DDR SDRAMs that have been validated by IDT to meet the requirements for the DDR SDRAM interface.

TABLE 1 – DDR SDRAM MINIMUM SPECIFICATIONS

DDR SDRAM Minimum Specifications					
Symbol		Parameter	16-bit DDR SDRAM	32-bit DDR SDRAM	Units
tCK	CL = 2.5	Clock cycle time	6	n/a	ns
	CL = 3.0		n/a	6	
tRFC		Auto refresh command period	75	63	ns
tRCD		Active to read/write delay	20	n/a	ns
tRP		Precharge command period	20	18	ns
tWR		Write recovery time	15	1.5	ns
tRCDRD		Active to read delay	n/a	18	ns
tRCDWR		Active to write delay	n/a	9	ns

NOTE:

1. These are the minimum specifications that the DDR SDRAM must meet.

TABLE 2 – SUPPORTED MEMORY VENDORS

Density	Bus Width	Vendor	Part#
128Mb	32	Samsung	K4D263238"X"-GC45
256Mb	16	Samsung	K4H561638"X"-TCLB3
			K4H561638"X"-GCLB3
256Mb	16	Micron	MT46V16M16TG-6T
			MT46V16M16TG-75
256Mb	16	Infineon	HYB25D256160BTL-6
			HYB25D256160BTL-7
256Mb	32	Samsung	K4D553238"X"-JC50

NOTES:

1. The part numbers listed above include packages that are recommended and validated by IDT. Other packages (such as lead free PCB, FBGA, etc.) may also be used but have not been validated by IDT.
2. The letter "X" for Samsung memory part numbers denotes the latest die revision for that particular device. Check with Samsung for the latest updated part number.

EXTERNAL MEMORY CONFIGURATIONS

The DDR SDRAM interface of the sequential flow-control (SFC) device has a 64-bit output data bus that provides up to four (16-bit SDRAM) external DDR SDRAM connections. For multiple memory connections, they must be of the same density configuration and speed grade. For example, two device connected cannot consist of one 128Mb and one 256Mb memory nor two 128Mb with one at 133MHz and the other at 166MHz. Below is a summary of the possible configurations:

- One 16-bit device connecting a x16 interface to the DDR SDRAM
- One 32-bit device connecting a x32 interface to the DDR SDRAM

- Two 16-bit devices connecting a x32 interface to the DDR SDRAM
- Two 32-bit devices connecting a x36 interface to the DDR SDRAM
- Two 32-bit devices connecting a x64 interface to the DDR SDRAM
- Three 16-bit devices connecting a x36 interface to the DDR SDRAM
- Four 16-bit devices connecting a x64 interface to the DDR SDRAM

These various configurations determine the storage density of the SFC device. The storage density can range from a minimum of 128Mb to a maximum of 1Gb. Table 3 lists the possible ways to connect the DDR SDRAMs and the number of chipset solutions to obtain the various storage densities.

TABLE 3 – TOTAL POSSIBLE EXTERNAL MEMORY CONFIGURATIONS

Two Chip Solution ⁽¹⁾	Three Chip Solution ⁽¹⁾	Four Chip Solution ⁽¹⁾	Five Chip Solution ⁽¹⁾
⁽²⁾ Configuration 1, 2	⁽²⁾ Configurations 3, 4, 5	⁽²⁾ Configuration 6	⁽²⁾ Configuration 7
1 x 128Mb [4M x 32] Total memory: 128Mb	2 x 128Mb [4M x 32] Total memory: 256Mb	N/A	N/A
1 x 256Mb [8M x 32] Total memory: 256Mb	2 x 256Mb [8M x 32] Total memory: 512Mb	N/A	N/A
1 x 128Mb [8M x 16] Total memory: 128Mb	2 x 128Mb [8M x 16] Total memory: 256Mb	3 x 128Mb [8M x 16] Total memory: 384Mb	4 x 128Mb [8M x 16] Total memory: 512Mb
1 x 256Mb [16M x 16] Total memory: 256Mb	2 x 256Mb [16M x 16] Total memory: 512Mb	3 x 256Mb [16M x 16] Total memory: 768Mb	4 x 256Mb [16M x 16] Total memory: 1Gb

NOTES:

1. The chip solution number includes the sequential flow-control device and external DDR SDRAM
2. See Figure 2a-2g for the 7 different configurations referenced in the table above.

CONNECTING THE DDR SDRAM

Below are the various chipset solution configurations available to the sequential flow-control device (see Figure 2a-2g). The external memory interface is designed to seamlessly connect one or more DDR SDRAMs. The output signal names should be connected directly to its corresponding input signal on the DDR SDRAM. There are three signals on the DDR SDRAM that must be tied to a static state. CKE, \overline{CS} , and DM. Table 4 outlines how to connect the many interface pins to the DDR SDRAM(s). Figure 3 and 4 are some examples of the memory interface connections for various density configurations. For information on DDR SDRAM layout recommendations, please see IDT application note AN-423.

DDR SDRAM: 128Mb [4Mb x 32] or 256Mb [8Mb x 32]
Total Memory Density: 128Mb or 256Mb
Useable Memory⁽²⁾: 108Mb or 252Mb

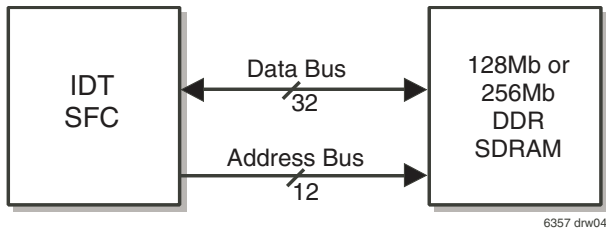

Figure 2a. Configuration 1 - Two Chip Solution

DDR SDRAM: 256Mb [16Mb x 16]
Total Memory Density: 256Mb
Useable Memory⁽²⁾: 216Mb

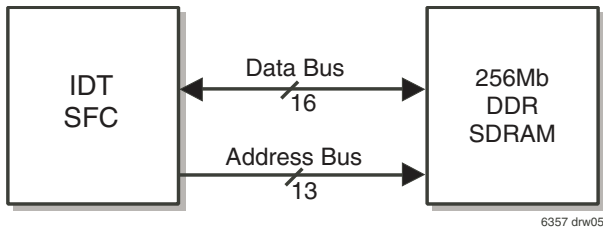

Figure 2b⁽¹⁾. Configuration 2 - Two Chip Solution

DDR SDRAM: 128Mb [4Mb x 32] or 256Mb [8Mb x 32]
Total Memory Density: 256Mb or 512Mb
Useable Memory⁽²⁾: 216Mb or 504Mb

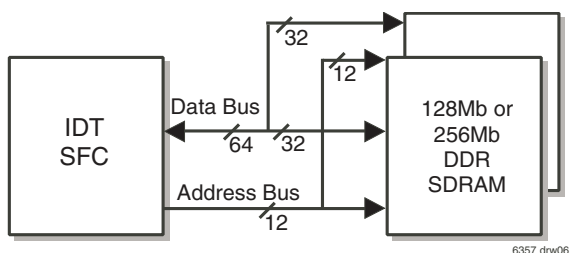

Figure 2c. Configuration 3 - Three Chip Solution

NOTES:

- 12-bit address bus for 8Mb x16
• 13-bit address bus for 16Mb x16
- Refer to Total Available Memory Usage section for details.

DDR SDRAM: 128Mb [4Mb x 32] or 256Mb [8Mb x 32]
Total Memory Density: 256Mb or 512Mb
Useable Memory⁽²⁾: 108Mb or 252Mb

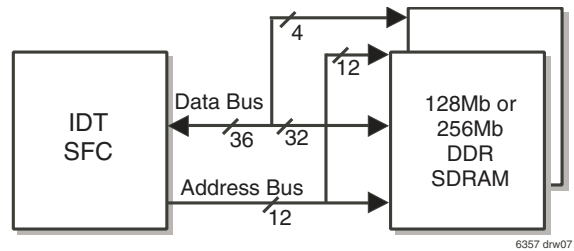

Figure 2d. Configuration 4 - Three Chip Solution

DDR SDRAM: 256Mb [16Mb x 16]
Total Memory Density: 512Mb
Useable Memory⁽²⁾: 504Mb

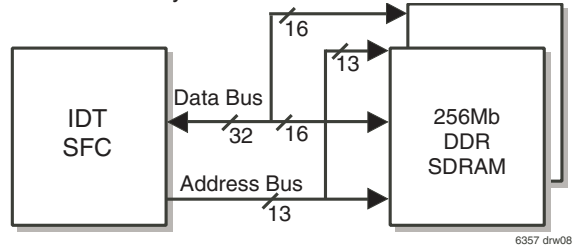

Figure 2e⁽¹⁾. Configuration 5 - Three Chip Solution

DDR SDRAM: 256Mb [16Mb x 16]
Total Memory Density: 768Mb
Useable Memory⁽²⁾: 567Mb

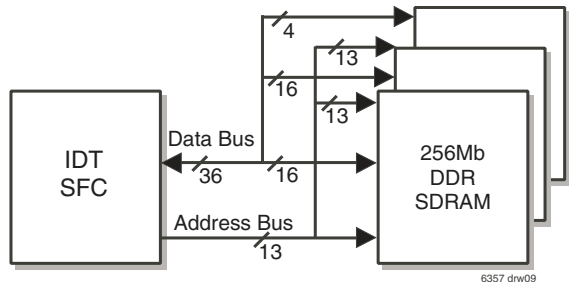

Figure 2f⁽¹⁾. Configuration 6 - Four Chip Solution

DDR SDRAM: 256Mb [16Mb x 16]
Total Memory Density: 1Gb
Useable Memory⁽²⁾: 1008Mb

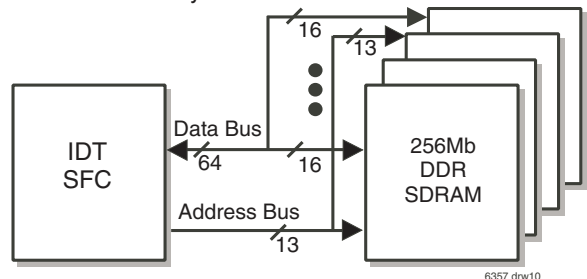
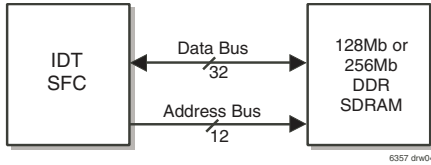

Figure 2g⁽¹⁾. Configuration 7 - Five Chip Solution

TABLE 4 – SFC TO DDR SDRAM INTERFACE CONNECTIONS



CONFIGURATION 1

SFC Outputs	DDR SDRAM
DQ[31:0]	DQ[31:0]
DQS[3:0]	DQS[3:0]
A[11:0]	A[11:0]
CK, \overline{CK}	CK, \overline{CK}
\overline{RAS} , \overline{CAS}	\overline{RAS} , \overline{CAS}
BA[1:0]	BA[1:0]
\overline{WE}	\overline{WE}
DDR SDRAM Hard wired pins	
CKE → Vcc	
\overline{CS} → GND	
DM[3:0] → GND	
SFC Hard wired pins	
DQ[63:32] → Vcc	
DQS[7:4] → Vcc	
A12 → Vcc	

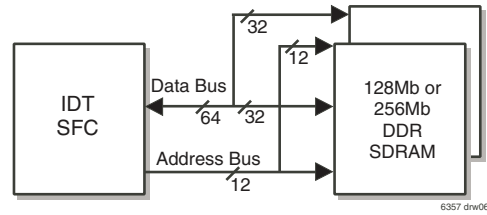

CONFIGURATION 3

SFC Outputs	DDR SDRAM #1	DDR SDRAM #2
DQ[31:0]	DQ[31:0]	--
DQ[63:32]	--	DQ[31:0]
DQS[3:0]	DQS[3:0]	--
DQS[7:4]	--	DQS[3:0]
A[11:0]	A[11:0]	A[11:0]
CK, \overline{CK}	CK, \overline{CK}	CK, \overline{CK}
\overline{RAS} , \overline{CAS}	\overline{RAS} , \overline{CAS}	\overline{RAS} , \overline{CAS}
BA[1:0]	BA[1:0]	BA[1:0]
\overline{WE}	\overline{WE}	\overline{WE}
DDR SDRAM Hard wired pins		
CKE → Vcc		
\overline{CS} → GND		
DM[3:0] → GND		
SFC Hard wired pins		
A12 → Vcc		

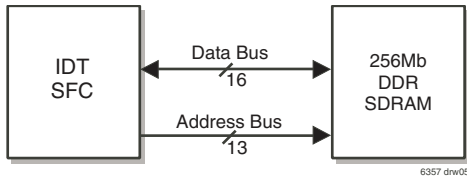

CONFIGURATION 2

SFC Outputs	DDR SDRAM
DQ[15:0]	DQ[15:0]
DQS0	LDQS
DQS1	UDQS
A[12:0]	A[12:0]
CK, \overline{CK}	CK, \overline{CK}
\overline{RAS} , \overline{CAS}	\overline{RAS} , \overline{CAS}
BA[1:0]	BA[1:0]
\overline{WE}	\overline{WE}
DDR SDRAM Hard wired pins	
CKE → Vcc	
\overline{CS} → GND	
LDM → GND	
UDM → GND	
SFC Hard wired pins	
DQ[63:16] → Vcc	
DQS[7:2] → Vcc	

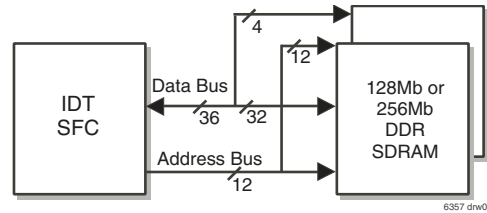

CONFIGURATION 4

SFC Outputs	DDR SDRAM #1	DDR SDRAM #2
DQ[31:0]	DQ[31:0]	--
DQ[35:32]	--	DQ[3:0]
DQ[63:36]	--	--
DQS[3:0]	DQS[3:0]	--
DQS[7:4]	--	DQS[3:0]
A[11:0]	A[11:0]	A[11:0]
CK, \overline{CK}	CK, \overline{CK}	CK, \overline{CK}
\overline{RAS} , \overline{CAS}	\overline{RAS} , \overline{CAS}	\overline{RAS} , \overline{CAS}
BA[1:0]	BA[1:0]	BA[1:0]
\overline{WE}	\overline{WE}	\overline{WE}
DDR SDRAM Hard wired pins		
CKE → Vcc		
\overline{CS} → GND		
DM[3:0] → GND		
DQ[31:4] → Vcc		
SFC Hard wired pins		
A12 → Vcc		

TABLE 4 – SFC TO DDR SDRAM INTERFACE CONNECTIONS(Continued)

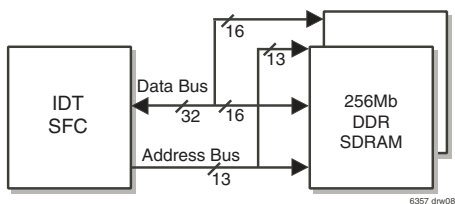

CONFIGURATION 5

SFC Outputs	DDR SDRAM #1	DDR SDRAM #2
DQ[15:0]	DQ[15:0]	--
DQ[31:16]	--	DQ[15:0]
DQS0	LDQS	--
DQS1	UDQS	--
DQS2	--	LDQS
DQS3	--	UDQS
A[12:0]	A[12:0]	A[12:0]
CK, \overline{CK}	CK, \overline{CK}	CK, \overline{CK}
\overline{RAS} , \overline{CAS}	\overline{RAS} , \overline{CAS}	\overline{RAS} , \overline{CAS}
BA[1:0]	BA[1:0]	BA[1:0]
\overline{WE}	\overline{WE}	\overline{WE}
DDR SDRAM Hard wired pins		
CKE → Vcc		
\overline{CS} → GND		
LDM → GND		
UDM → GND		
SFC Hard wired pins		
DQ[63:32] → Vcc		
DQS[7:2] → Vcc		

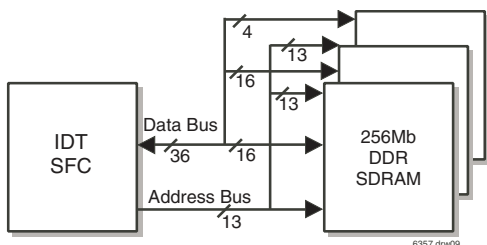

CONFIGURATION 6

SFC Outputs	DDR SDRAM #1	DDR SDRAM #2	DDR SDRAM #3
DQ[15:0]	DQ[15:0]	--	--
DQ[31:16]	--	DQ[15:0]	--
DQ[35:32]	--	--	DQ[3:0]
DQS0	LDQS	--	--
DQS1	UDQS	--	--
DQS2	--	LDQS	--
DQS3	--	UDQS	--
DQS4	--	--	LDQS
DQS5	--	--	UDQS
A[12:0]	A[12:0]	A[12:0]	A[12:0]
CK, \overline{CK}	CK, \overline{CK}	CK, \overline{CK}	CK, \overline{CK}
\overline{RAS} , \overline{CAS}	\overline{RAS} , \overline{CAS}	\overline{RAS} , \overline{CAS}	\overline{RAS} , \overline{CAS}
BA[1:0]	BA[1:0]	BA[1:0]	BA[1:0]
\overline{WE}	\overline{WE}	\overline{WE}	\overline{WE}
DDR SDRAM Hard wired pins			
CKE → Vcc			
\overline{CS} → GND			
LDM → GND			
UDM → GND			
DQ[15:4] → Vcc			
SFC Hard wired pins			
DQ[63:36] → Vcc			
DQS[7:6] → Vcc			

TABLE 4 – SFC TO DDR SDRAM INTERFACE CONNECTIONS(Continued)

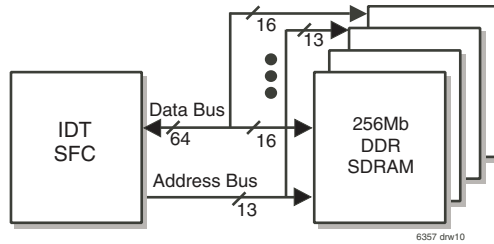

CONFIGURATION 7

SFC Outputs	DDR SDRAM #1	DDR SDRAM #2	DDR SDRAM #3	DDR SDRAM #4
DQ[15:0]	DQ[15:0]	--	--	--
DQ[31:16]	--	DQ[15:0]	--	--
DQ[47:32]	--	--	DQ[15:0]	--
DQ[63:48]	--	--	--	DQ[15:0]
DQS0	LDQS	--	--	--
DQS1	UDQS	--	--	--
DQS2	--	LDQS	--	--
DQS3	--	UDQS	--	--
DQS4	--	--	LDQS	--
DQS5	--	--	UDQS	--
DQS6	--	--	--	LDQS
DQS7	--	--	--	UDQS
A[12:0]	A[12:0]	A[12:0]	A[12:0]	A[12:0]
CK, \overline{CK}	CK, \overline{CK}	CK, \overline{CK}	CK, \overline{CK}	CK, \overline{CK}
\overline{RAS} , \overline{CAS}	\overline{RAS} , \overline{CAS}	\overline{RAS} , \overline{CAS}	\overline{RAS} , \overline{CAS}	\overline{RAS} , \overline{CAS}
BA[1:0]	BA[1:0]	BA[1:0]	BA[1:0]	BA[1:0]
\overline{WE}	\overline{WE}	\overline{WE}	\overline{WE}	\overline{WE}
DDR SDRAM Hard wired pins				
CKE → Vcc				
\overline{CS} → GND				
LDM → GND				
UDM → GND				

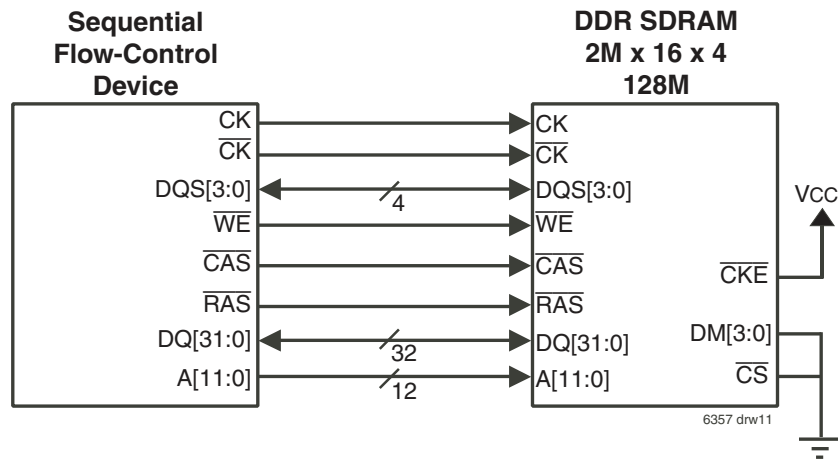

Figure 3. Memory Interface Connection (Single Chip)

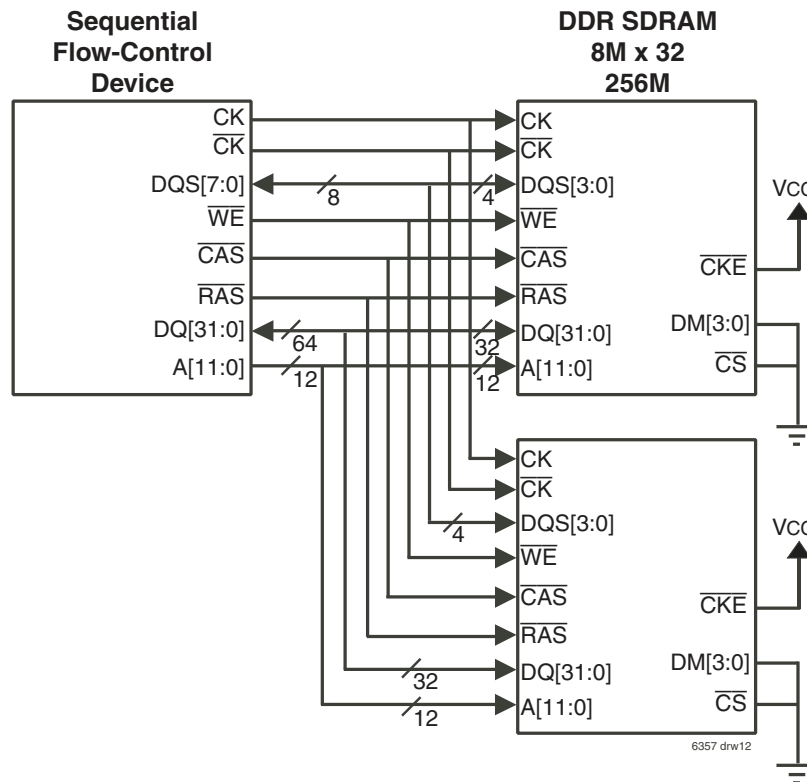

Figure 4. Memory Interface Connection (Two Chip)

TOTAL AVAILABLE MEMORY USAGE

The sequential flow-control (SFC) is designed to efficiently use as much of the DDR SDRAM memory as possible, but due to the discontinuity between the SFC bus width (x36) and the DDR SDRAM interface (x16 or x32), some columns in a row of the SDRAM will not be used. As a result, the total usable memory will be slightly less than the total available memory in the SDRAM. Table 5 outlines the total usable memory for the various configurations depending on

whether or not the Error Detection and Correction (EDC) feature is selected. If the EDC feature is selected, 8 syndrome bits will be generated per every 64 bits of data. Therefore every third write burst to the SDRAM will send out the 8 syndrome bits, resulting in 24 unused bits in the column. Therefore, using the EDC feature, there will be significantly less usable memory of data storage. The EDC function is described in the Error Detection and Correction section of this datasheet.

TABLE 5 – TOTAL USEABLE MEMORY BASED ON VARIOUS CONFIGURATIONS

	Total DDR SDRAM Density	Total Usable Memory (EDC off)	Total Usable Memory (EDC on)
Configuration 1			
1 x [4Mb x 32]	128Mb	108Mb	72Mb
1 x [8Mb x 32]	256Mb	252Mb	144Mb
Configuration 2			
1 x [8Mb x 16]	128Mb	108Mb	72Mb
1 x [16Mb x 16]	256Mb	216Mb	144Mb
Configuration 3			
2 x [4Mb x 32]	256Mb	216Mb	144Mb
2 x [8Mb x 32]	512Mb	504Mb	288Mb
Configuration 4			
2 x [4Mb x 32]	256Mb	122Mb	108Mb
2 x [8Mb x 32]	512Mb	284Mb	252Mb
Configuration 5			
2 x [8Mb x 16]	256Mb	252Mb	144Mb
2 x [16Mb x 16]	512Mb	504Mb	288Mb
Configuration 6			
3 x [8Mb x 16]	384Mb	284Mb	252Mb
3 x [16Mb x 16]	768Mb	567Mb	504Mb
Configuration 7			
4 x [8Mb x 16]	512Mb	504Mb	288Mb
4 x [16Mb x 16]	1Gb	1008Mb	576Mb

MAXIMUM I/O OPERATING FREQUENCY

The sequential flow-control (SFC) device is designed to operate at the maximum frequency of 133MHz. There are certain configurations however, that can increase or decrease the maximum frequency of the input and output ports. In some configurations (e.g. x24 I/O width), the I/O speeds can run up to

166MHz. The main factors that determine the usable memory are the I/O bus-width of the SFC, the density and number of DDR SDRAMs connected, and whether or not EDC is used. Tables 6 and 7 lists the maximum frequency for the input and output ports of the SFC based on the various configurations.

TABLE 6 – IDT72T6360 MAXIMUM FREQUENCY BASED ON 166MHz DDR SDRAM

	Bus-Width x36		Bus-Width x18		Bus-Width x9	
	EDC On	EDC Off	EDC On	EDC Off	EDC On	EDC Off
Configuration 1	66MHz	83MHz	133MHz	166MHz	166MHz	166MHz
Configuration 2	33MHz	50MHz	83MHz	166MHz	166MHz	166MHz
Configuration 3	133MHz	166MHz	166MHz	166MHz	166MHz	166MHz
Configuration 4	83MHz	100MHz	166MHz	166MHz	166MHz	166MHz
Configuration 5	66MHz	83MHz	133MHz	166MHz	166MHz	166MHz
Configuration 6	83MHz	100MHz	166MHz	166MHz	166MHz	166MHz
Configuration 7	133MHz	166MHz	166MHz	166MHz	166MHz	166MHz

TABLE 7 – IDT72T6360 MAXIMUM FREQUENCY BASED ON 133MHz DDR SDRAM

	Bus-Width x36		Bus-Width x18		Bus-Width x9	
	EDC On	EDC Off	EDC On	EDC Off	EDC On	EDC Off
Configuration 1	50MHz	66MHz	100MHz	133MHz	166MHz	166MHz
Configuration 2	33MHz	33MHz	66MHz	83MHz	133MHz	166MHz
Configuration 3	100MHz	133MHz	166MHz	166MHz	166MHz	166MHz
Configuration 4	66MHz	83MHz	133MHz	166MHz	166MHz	166MHz
Configuration 5	50MHz	66MHz	100MHz	133MHz	166MHz	166MHz
Configuration 6	66MHz	83MHz	133MHz	166MHz	166MHz	166MHz
Configuration 7	100MHz	133MHz	166MHz	166MHz	166MHz	166MHz

ERROR DETECTION AND CORRECTION

The Error Detection and Correction (EDC) feature is available to ensure data integrity between the DDR SDRAM interface and the SFC. The EDC corrects all single bit hard and soft errors that are accessed from the DDR SDRAM. Multiple bit errors are not detected nor corrected.

The EDC logic blocks consist of a check bit generator and error detection correction logic. When the EDC is enabled, the check bit generator will generate 8 syndrome bits on the 8-byte boundary. The 8 syndrome bits are written into the DDR SDRAM along with the data. The SFC will burst write two cycles for data, and one cycle for syndrome bits. In order to minimize overhead and

increase throughput, not all memory in the DDR SDRAM is utilized. Table 5 lists the total usable memory for all 7 configurations when the EDC is enabled.

When a read operation is performed, the syndrome bits will be transferred to the error detection correction logic block and decoded to determine whether there are any single bit errors on the data. Single bit errors will be corrected and data is passed through to the QP cache.

The EDC is enabled using the MIC[2:0] pins. When the EDC is enabled, the dynamics of the total usable memory in the DDR SDRAM and the SFC operating speed will vary, listed in Tables 6 and 7. Table 8 shows how to enable the EDC feature for the 7 configurations

TABLE 8 – MIC[2:0] CONFIGURATIONS

	EDC Off	EDC On
Configuration 1	MIC [2:0] = 000	MIC [2:0] = 010
Configuration 2	MIC [2:0] = 001	MIC [2:0] = 011
Configuration 3	MIC [2:0] = 111	MIC [2:0] = 101
Configuration 4	MIC [2:0] = 100	MIC [2:0] = 110
Configuration 5	MIC [2:0] = 000	MIC [2:0] = 010
Configuration 6	MIC [2:0] = 100	MIC [2:0] = 110
Configuration 7	MIC [2:0] = 111	MIC [2:0] = 101

SETTING THE MEMORY INTERFACE SIGNALS

The configurations listed in Figure 2a-2g can be programmed into the sequential flow-control device by using the MIC[2:0], MTYPE[1:0], and

MSPEED. For information about these signals, please refer to the Signal Description section. Table 9 is a list that shows the settings for the different configurations.

TABLE 9 – MEMORY CONFIGURATIONS SETTINGS

	MIC[2:0]	MTYPE[1:0]	MSPEED
Configuration 1	000 - EDC Off 010 - EDC On	00 - (4Mb x 32) 10 - (8Mb x 32)	0 - 133MHz 1 - 166MHz
Configuration 2	001 - EDC Off 011 - EDC On	— 11 - (16Mb x 16)	0 - 133MHz 1 - 166MHz
Configuration 3	111 - EDC Off 101 - EDC On	00 - (4Mb x 32) 10 - (8Mb x 32)	0 - 133MHz 1 - 166MHz
Configuration 4	110 - EDC Off 100 - EDC On	00 - (4Mb x 32) 10 - (8Mb x 32)	0 - 133MHz 1 - 166MHz
Configuration 5	000 - EDC Off 010 - EDC On	— 11 - (16Mb x 16)	0 - 133MHz 1 - 166MHz
Configuration 6	110 - EDC Off 100 - EDC On	— 11 - (16Mb x 16)	0 - 133MHz 1 - 166MHz
Configuration 7	111 - EDC Off 101 - EDC On	— 11 - (16Mb x 16)	0 - 133MHz 1 - 166MHz

TABLE 10 – DEVICE CONFIGURATION

Signal Pins	Static State	Configuration
$\overline{\text{ASYR}}$	0	Read port configured in asynchronous mode
	1	Read port configured in synchronous mode
$\overline{\text{ASYW}}$	0	Write port configured in asynchronous mode
	1	Write port configured in synchronous mode
BM[3:0]	—	See Table 13 - Bus-Matching Configurations
FSEL[1:0]	00	Programmable flag register offset value = 127
	01	Programmable flag register offset value = 1,023
	10	Programmable flag register offset value = 4,095
	11	Programmable flag register offset value = 16,383
FWFT	0	IDT Standard mode
	1	FWFT mode
IDEM	0	Depth expansion in FWFT mode
	1	Depth expansion in IDT Standard mode
IOSEL	0	I/O voltage set to 3.3V levels
	1	I/O voltage set to 2.5V levels
JSEL	0	JTAG function is disabled
	1	JTAG function is enabled
MIC[2:0]	—	See Table 8 - MIC[2:0] Configurations for description
MSPEED	0	External memory interface clocks set to 133MHz
	1	External memory interface clocks set to 166MHz
MTYPE[1:0]	00	External memory configuration is: 4M x 32
	01	Not used
	10	External memory configuration is: 8M x 32
	11	External memory configuration is: 16M x 16

TABLE 11 – DEFAULT PROGRAMMABLE FLAG OFFSETS

FSEL1	FSEL0	Offset n,m
0	0	127
0	1	1,023
1	0	4,095
1	1	16,383

TABLE 12 – NUMBER OF BITS REQUIRED FOR OFFSET REGISTERS

Write Port Bus-Width	x48		x24		x12	
	EDC On	EDC Off	EDC On	EDC Off	EDC On	EDC Off
Configuration 1 (128Mb)	21	22	22	23	23	24
Configuration 1 (256Mb)	22	23	23	24	24	25
Configuration 2 (256Mb)	22	23	23	24	24	25
Configuration 3 (256Mb)	22	23	23	24	24	25
Configuration 3 (512Mb)	23	24	24	25	25	26
Configuration 4 (256Mb)	22	22	23	23	24	24
Configuration 4 (512Mb)	23	23	24	24	25	25
Configuration 5 (512Mb)	23	24	24	25	25	26
Configuration 6 (768Mb)	24	24	25	25	26	26
Configuration 7 (1Gb)	24	25	25	26	26	27

FUNCTIONAL DESCRIPTIONS

MASTER RESET AND DEVICE CONFIGURATION

During master reset the sequential flow-control configuration and settings are determined, this includes the following:

1. Synchronous or Asynchronous read and write port operation
2. Bus-width configuration
3. Default offset register values
4. IDT standard or first word fall through (FWFT) timing mode
5. Depth expansion in IDT standard or FWFT mode
6. I/O voltage set to 2.5V or 3.3V levels
7. JTAG function enabled or disabled
8. Configuration of the external memory interface

The state of the configuration inputs during master reset will determine which of the above modes are selected. A master reset comprises of pulsing the $\overline{\text{MRS}}$ input pin from high to low for a period of time (t_{RS}) with the configuration inputs held in their respective states. Table 10 summarizes the configuration modes available during master reset. These signals are described in detail in the signal description section.

PROGRAMMABLE ALMOST EMPTY/ALMOST FULL FLAGS

The SFC has a set of programmable flags ($\overline{\text{PAE}}/\overline{\text{PAF}}$) that can be used as an early indicator for the empty and full boundary conditions. These flags have an offset value (n, m) that will determine the almost empty and almost full boundary conditions. There are four default offset values selectable during master reset, these values are shown in Table 11, Default Programmable Flag Offsets.

Offset values can also be programmed using the serial programming pins (SCLK , SI , and $\overline{\text{SWEN}}$). The SFC has two internal offset registers that are used to store the specific offset value, one for the $\overline{\text{PAE}}$ and one for the $\overline{\text{PAF}}$. The total number of bits (shown in Table 12, Number of Bits Required for Offset Registers) must be completely programmed to the offset registers. The serial programming sequence begins by writing data into the $\overline{\text{PAE}}$ register followed by the $\overline{\text{PAF}}$ register. See Figure 29, *Serial Loading of Programmable Flag Registers* for the associated timing diagram. The total number of bits required to program the offset registers will vary depending on the type of configuration that is shown in Figure 2a-2g, the bus-width selected, and whether EDC is used.

The values of n, m are used such that the $\overline{\text{PAE}}$ will become active (LOW) when there are at least one to n words written in the device. Similarly $\overline{\text{PAF}}$ will become active (LOW) when there are at least D – M words or more in the device, where D is the density of the SFC.

SIGNAL DESCRIPTIONS

INPUTS

DATA INPUTS (D0 - D35)

Data inputs for 36-bit wide data (D0 - D35), data inputs for 18-bit wide data (D0 - D17) or data inputs for 9-bit wide data (D0 - D8).

CONTROLS

MASTER RESET (\overline{MRS})

A Master Reset is accomplished whenever the \overline{MRS} input is toggled LOW then HIGH. This operation sets the internal read and write pointers to the first location of the RAM array. \overline{PAE} will go LOW, \overline{PAF} will go HIGH.

If FWFT is LOW during Master Reset then the IDT Standard mode, along with \overline{EF} and \overline{FF} are selected. \overline{EF} will go LOW and \overline{FF} will go HIGH. If FWFT is HIGH, then the First Word Fall Through mode (FWFT), along with \overline{IR} and \overline{OR} , are selected. \overline{OR} will go HIGH and \overline{IR} will go LOW.

All configuration control signals must be set prior to the LOW to HIGH transition of \overline{MRS} .

During a Master Reset, the output register is initialized to all zeroes. A Master Reset is required after power up, before a write operation can take place. \overline{MRS} is an asynchronous function.

See Figure 6, *Master Reset and Initialization*, for the relevant timing diagram.

PARTIAL RESET (\overline{PRS})

A Partial Reset is accomplished whenever the \overline{PRS} input is toggled LOW then HIGH. As in the case of the Master Reset, the internal read and write pointers are set to the first location of the RAM array, \overline{PAE} goes LOW, and \overline{PAF} goes HIGH.

Whichever mode is active at the time of Partial Reset, IDT Standard mode or First Word Fall Through, that mode will remain selected. If the IDT Standard mode is active, then \overline{FF} will go HIGH and \overline{EF} will go LOW. If the First Word Fall Through mode is active, then \overline{OR} will go HIGH, and \overline{IR} will go LOW.

Following Partial Reset, all values held in the offset registers remain unchanged. The output register is initialized to all zeroes. \overline{PRS} is asynchronous.

A Partial Reset is useful for resetting the device during the course of operation, when reprogramming programmable flag offset settings may not be convenient.

See Figure 7, *Partial Reset*, for the relevant timing diagram.

ASYNCHRONOUS WRITE (\overline{ASYW})

The write port can be configured for either synchronous or asynchronous mode of operation. If during Master Reset the \overline{ASYW} input is LOW, then asynchronous operation of the write port will be selected. During asynchronous operation of the write port the WCLK input becomes WR input, this is the asynchronous write strobe input. A rising edge on WR will write data present on the data inputs into the sequential flow-control device (SFC). (\overline{WEN} must be LOW when using the write port in asynchronous mode).

When the write port is configured for asynchronous operation the device must be operating on IDT standard mode, FWFT mode is not permissible. The full flag (\overline{FF}) and programmable almost full flag (\overline{PAF}) operates in an asynchronous manner, that is, the full flag and \overline{PAF} flag will be updated based in both a write operation and read operation. Note, if asynchronous mode is selected, FWFT is not permissible. Refer to Figure 24, *Asynchronous Write and \overline{PAE} flag – IDT Standard mode* and Figure 25, *Asynchronous Write and \overline{PAF} flag – IDT Standard mode* for relevant timing and operational waveforms.

ASYNCHRONOUS READ (\overline{ASYR})

The read port can be configured for either synchronous or asynchronous mode of operation. If during a Master Reset the \overline{ASYR} input is LOW, then

asynchronous operation of the read port will be selected. During asynchronous operation of the read port the RCLK input becomes RD input, this is the asynchronous read strobe input. A rising edge on RD will read data from the SFC via the output register and data output port. (\overline{REN} must be tied LOW during asynchronous operation of the read port).

The \overline{OE} input provides three-state control of the Qn output bus, in an asynchronous manner.

When the read port is configured for asynchronous operation the device must be operating on IDT standard mode, FWFT mode is not permissible if the read port is asynchronous. The Empty Flag (\overline{EF}) and programmable almost empty flag (\overline{PAE}) operates in an asynchronous manner, that is, the empty flag and \overline{PAE} will be updated based on both a read operation and a write operation. Refer to Figure 23, *Asynchronous Read and \overline{PAF} flag – IDT Standard mode*, Figure 26, *Asynchronous Empty Boundary – IDT Standard mode*, Figure 27, *Asynchronous Full Boundary – IDT Standard mode*, and Figure 28, *Asynchronous Read and \overline{PAE} flag – IDT Standard mode*, for relevant timing and operational waveforms.

FIRST WORD FALL THROUGH (FWFT)

During Master Reset, the state of the FWFT input determines whether the device will operate in IDT standard mode or First Word Fall Through (FWFT) mode.

If, at the time of Master Reset, FWFT is LOW, then IDT Standard mode will be selected. This mode uses the Empty Flag (\overline{EF}) to indicate whether or not there are any words present in the SFC. It also uses the Full Flag function (\overline{FF}) to indicate whether or not the SFC has any free space for writing. In IDT Standard mode, every word read from the SFC, including the first, must be requested using the Read Enable (\overline{REN}) and RCLK.

If, at the time of Master Reset, FWFT is HIGH, then FWFT mode will be selected. This mode uses Output Ready (\overline{OR}) to indicate whether or not there is valid data at the data outputs (Qn). It also uses Input Ready (\overline{IR}) to indicate whether or not the SFC has any free space for writing. In the FWFT mode, the first word written to an empty SFC goes directly to Qn after three RCLK rising edges, $\overline{REN} = \text{LOW}$ is not necessary. Subsequent words must be accessed using the Read Enable (\overline{REN}) and RCLK.

WRITE STROBE AND WRITE CLOCK (WR/WCLK)

If synchronous operation of the write port has been selected via \overline{ASYW} , this input behaves as WCLK.

A write cycle is initiated on the rising edge of the WCLK input. Data setup and hold times must be met with respect to the LOW-to-HIGH transition of the WCLK. It is permissible to stop the WCLK. Note that while WCLK is idle, the $\overline{FF}/\overline{IR}$, and \overline{PAF} flags will not be updated. The Write and Read Clocks can either be independent or coincident.

If asynchronous operation has been selected this input is WR (write strobe). Data is asynchronously written into the SFC via the Dn inputs whenever there is a rising edge on WR. In this mode the \overline{WEN} input must be LOW.

WRITE ENABLE (\overline{WEN})

When the \overline{WEN} input is LOW, data may be loaded into the SFC on the rising edge of every WCLK cycle if the device is not full. Data is stored in the RAM array sequentially and independently of any ongoing read operation.

When \overline{WEN} is HIGH, no new data is written in the SFC.

To prevent data overflow in the IDT Standard mode, \overline{FF} will go LOW, inhibiting further write operations. Upon the completion of a valid read cycle, \overline{FF} will go HIGH allowing a write to occur. The \overline{FF} is updated by two WCLK cycles + t_{SKEW} after the RCLK cycle.

To prevent data overflow in the FWFT mode, \overline{IR} will go HIGH, inhibiting further write operations. Upon the completion of a valid read cycle, \overline{IR} will go LOW allowing a write to occur. The \overline{IR} flag is updated by two WCLK cycles + tSKEW after the valid RCLK cycle.

\overline{WEN} is ignored when the SFC is full in either FWFT or IDT Standard mode.

If asynchronous operation of the write port has been selected, then \overline{WEN} must be held active.

READ STROBE AND READ CLOCK (RD/RCLK)

If synchronous operation of the read port has been selected via \overline{ASYR} , this input behaves as RCLK. A read cycle is initiated on the rising edge of the RCLK input. Data can be read on the outputs, on the rising edge of the RCLK input. It is permissible to stop the RCLK. Note that while RCLK is idle, the $\overline{EF}/\overline{OR}$ and \overline{PAE} flags will not be updated. The Write and Read Clocks can be independent or coincident.

If asynchronous operation has been selected this input is RD (Read Strobe). Data is asynchronously read from the SFC whenever there is a rising edge on RD. In this mode the \overline{REN} and \overline{RCS} inputs must be tied LOW. The \overline{OE} input is used to provide asynchronous control of the three-state Qn outputs.

WRITE CHIP SELECT (\overline{WCS})

The \overline{WCS} disables all Write data operations (data only) if it is held HIGH. To perform normal operations on the write port, the \overline{WCS} must be enabled, held LOW.

READ ENABLE (\overline{REN})

When Read Enable is LOW, data is loaded from the RAM array into the output register on the rising edge of every RCLK cycle if the device is not empty.

When the \overline{REN} input is HIGH, the output register holds the previous data and then no new data is loaded into the output register. The data outputs Q0-Qn maintain the previous data value.

In the IDT Standard mode, every word accessed at Qn, including the first word written to an empty cache, must be requested using \overline{REN} provided that \overline{RCS} is LOW. When the last word has been read from the SFC, the Empty Flag (\overline{EF}) will go LOW, inhibiting further read operations. \overline{REN} is ignored when the SFC is empty. Once a write is performed, \overline{EF} will go HIGH allowing a read to occur. The \overline{EF} flag is updated by two RCLK cycles + tSKEW after the valid WCLK cycle. Both \overline{RCS} and \overline{REN} must be active, LOW for data to be read out on the rising edge of RCLK.

In the FWFT mode, the first word written to an empty SFC automatically goes to the outputs Qn, on the third valid LOW-to-HIGH transition of RCLK + tSKEW after the first write. \overline{REN} and \overline{RCS} do not need to be asserted LOW for the First Word to fall through to the output register. In order to access all other words, a read must be executed using \overline{REN} and \overline{RCS} . The RCLK LOW-to-HIGH transition after the last word has been read from the SFC, Output Ready (\overline{OR}) will go HIGH with a true read (RCLK with $\overline{REN} = \text{LOW}; \overline{RCS} = \text{LOW}$), inhibiting further read operations. \overline{REN} is ignored when the SFC is empty.

If asynchronous operation of the Read port has been selected, then \overline{REN} must be held active, (LOW).

OUTPUT ENABLE (\overline{OE})

When Output Enable is enabled (LOW), the parallel output buffers receive data from the output register. When \overline{OE} is HIGH, the output data bus (Qn) goes into a high impedance state. During Master or a Partial Reset the \overline{OE} is the only input that can place the output bus Qn, into High-Impedance. During Reset the \overline{RCS} input can be HIGH or LOW, it has no effect on the Qn outputs.

READ CHIP SELECT (\overline{RCS})

The Read Chip Select input provides synchronous control of the Read output port. When \overline{RCS} goes LOW, the next rising edge of RCLK causes the Qn outputs to go to the Low-Impedance state. When \overline{RCS} goes HIGH, the next RCLK rising edge causes the Qn outputs to return to HIGH-Z. During a Master or Partial Reset the \overline{RCS} input has no effect on the Qn output bus. \overline{OE} is the only input that provides High-Impedance control of the Qn outputs. If \overline{OE} is LOW the Qn data outputs will be Low-Impedance regardless of \overline{RCS} until the first rising edge of RCLK after a Reset is complete. Then if \overline{RCS} is HIGH the data outputs will go to High-Impedance.

The \overline{RCS} input does not effect the operation of the flags. For example, when the first word is written to an empty SFC, the \overline{EF} will still go from LOW to HIGH based on a rising edge of RCLK, regardless of the state of the \overline{RCS} input.

Also, when operating the SFC in FWFT mode the first word written to an empty SFC will still be clocked through to the output register based on RCLK, regardless of the state of \overline{RCS} . For this reason the user must take care when a data word is written to an empty SFC in FWFT mode. If \overline{RCS} is disabled when an empty SFC is written into, the first word will fall through to the output register, but will not be available on the Qn outputs which are in HIGH-Z. The user must take \overline{RCS} active LOW to access this first word, place the output bus in LOW-Z. \overline{REN} must remain disabled HIGH for at least one cycle after \overline{RCS} has gone LOW. A rising edge of RCLK with \overline{RCS} and \overline{REN} active LOW, will read out the next word. Care must be taken so as not to lose the first word written to an empty SFC when \overline{RCS} is HIGH. See Figure 15 for *Read Chip Select*. If asynchronous operation of the Read port has been selected, then \overline{RCS} must be held active, (tied LOW). \overline{OE} provides three-state control of Qn.

BUS-MATCHING (BM[3:0])

These pins are used to define the input and output bus widths. During Master Reset, the state of these pins is used to configure the device bus sizes. All flags will operate on the word/byte size boundary as defined by the selection of bus width. See Figures 22-25 for *Bus-Matching Configurations*. See Table 13, Bus-Matching Configurations for the available configurations.

TABLE 13 – BUS-MATCHINGS

BM3	BM2	BM1	BM0	Read Bus Width	Write Bus Width
1	0	0	0	x36	x36
1	0	0	1	x18	x36
1	1	0	1	x9	x36
1	0	1	1	x36	x18
1	1	1	1	x36	x9
0	0	0	1	x18	x18
0	1	0	1	x9	x18
0	0	1	1	x18	x9
0	1	1	1	x9	x9

FLAG SELECT (FSEL[1:0])

During master reset, these inputs will select one of four default values for the programmable flags \overline{PAE} and \overline{PAF} . The selected value (listed in Table 14 - MTYPE[1:0] Configurations) will apply to both \overline{PAE} and \overline{PAF} offset.

MEMORY CONFIGURATION (MIC[2:0])

These signals enable the EDC feature of the device. See Table 8, MIC[2:0] Configurations for more information.

MEMORY SPEED (MSPEED)

This pin is used to determine the memory interface clock speed (CK and \overline{CK}) for the external memory used. If MSPEED is HIGH, external memory CK and \overline{CK} will be operating at 166MHz. If MSPEED is LOW, then the external memory CK and \overline{CK} will be operating at 133MHz.

MASTER CLOCK (MCLK)

33MHz reference clock used to generate CK and \overline{CK} for external memory interface.

MEMORY TYPE (MTYPE[1:0])

These signals select the density configuration of the external DDR SDRAM used. See Table 14, for selection of the memory density configuration.

TABLE 14 – MTYPE[1:0] CONFIGURATIONS

	Density Configurations			
	4M x 32	8M x 32	Reserved	16M x 16
MTYPE0	0	0	1	1
MTYPE1	0	1	0	1

DEPTH EXPANSION MODE SELECT (IDEM)

This select pin is used for depth expansion configuration in IDT Standard mode. If this pin is tied HIGH, then the $\overline{FF}/\overline{IR}$ signal will be inverted to provide a seamless depth expansion interface. If this pin is tied LOW, the depth expansion in IDT Standard mode will be deactivated. For details on depth expansion configuration, see Figure 34, *Depth Expansion Configuration in IDT Standard Mode* and Figure 35, *Depth Expansion Configuration in FWFT Mode*.

SERIAL READ ENABLE (\overline{SREN})

The serial read enable input is an enable used for reading the value of the programmable offset registers. By setting the JSEL pin to LOW, the serial data output (SO) and serial clock (SCLK) signals can be used with \overline{SREN} to program the offset registers. When \overline{SREN} is LOW, data at the SO can be read from the offset register, one bit for each LOW-to-HIGH transition of SCLK. When serial read enable is HIGH, the reading of the offset registers will stop. \overline{SREN} must be kept LOW in order to read the entire contents of the scan out register. If at any point \overline{SREN} is toggled HIGH, the read pointer of the offset registers will reset to the first location. The next time \overline{SREN} is enabled the first contents in the offset register will be read back. Serial read enable functions the same way in both IDT Standard and FWFT modes. See Figure 30, *Reading of Programmable Flag Registers*, for the timing diagram.

SERIAL WRITE ENABLE (\overline{SWEN})

The serial write enable input is an enable used for serial programming of the programmable offset registers. By setting the JSEL pin to LOW, the serial input (SI) and serial clock (SCLK) signals can be used with \overline{SWEN} to program the offset registers. When \overline{SWEN} is LOW, data at the SI input are loaded into the offset register, one bit for each LOW-to-HIGH transition of SCLK. When \overline{SWEN} is HIGH, the offset registers retain the previous settings and no offsets are loaded. Serial write enable functions the same way in both Standard IDT and FWFT

modes. See Figure 29, *Loading of Programmable Flag Registers*, for the timing diagram.

I/O VDDQ SELECT (IOSEL)

This input determines whether the inputs and outputs will tolerate a 2.5V or 3.3V voltage signals. If IOSEL is HIGH, then all I/Os will be 2.5V levels. If IOSEL is LOW, then all I/Os will be 3.3V levels. See Table 15 for a list of affected I/O signals.

TABLE 15 – PARAMETERS AFFECTED BY I/O SELECTION

SFC I/O affected by I/O selection			DDR SDRAM I/O - NOT affected ⁽¹⁾	
ASYR	MIC[2:0]	RCS	A[12:0]	DQ[63:0]
ASYW	MCLK	REN	BA[1:0]	DQS[7:0]
BM[3:0]	MRS	SREN	CK	RAS
D[35:0]	MSPEED	SWEN	CK	WE
EF/OR	MTYPE[1:0]	TCK/SCLK	CAS	
FF/IR	OE	TDI/SI		
FSEL[1:0]	PAE	TDO/SO		
FWFT	PAF	TMS		
IDEM	PRS	WCLK/WR		
IOSEL	Q[35:0]	WCS		
JSEL	RCLK/RD	WEN		

NOTE:

1. I/O to DDR SDRAM is not affected by I/O voltage selection

JTAG SELECT (JSEL)

This input determines whether the JTAG port will be activated or deactivated. If JSEL is HIGH, then the JTAG port is activated and the associated JTAG pins (TCK, TDI, TDO, TMS) are used for the boundary-scan function. If JSEL is LOW, the JTAG port is disabled and the serial programming pins (SCLK, SI, SO) will be used to program and read the offset register values for \overline{PAE} and \overline{PAF} . See Figure 29 and 30, *Serial Loading and Reading of Programmable Registers* for information on how to program the registers.

OUTPUTS

FULL FLAG/INPUT READY ($\overline{FF}/\overline{IR}$)

This is a dual purpose pin. In IDT Standard mode, the Full Flag (\overline{FF}) function is selected. When the SFC is full, \overline{FF} will go LOW, inhibiting further write operations. When \overline{FF} is HIGH, the SFC is not full. If no reads are performed after a reset (either \overline{MRS} or \overline{PRS}), \overline{FF} will go LOW. See Figure 12, *Full Boundary - IDT Standard Mode*, for the relevant timing information.

In FWFT mode, the Input Ready (\overline{IR}) function is selected. \overline{IR} goes LOW when memory space is available for writing in data. When there is no longer any free space left, \overline{IR} goes HIGH, inhibiting further write operations. If no reads are performed after a reset (either \overline{MRS} or \overline{PRS}), \overline{IR} will go HIGH. See Figure 9 *Write First Word Cycles - FWFT Mode*, for the relevant timing information.

The \overline{IR} status not only measures the contents of the SFC memory, but also counts the presence of a word in the output register. Thus, in FWFT mode, the total number of writes necessary to de-assert \overline{IR} is one greater than needed to assert \overline{FF} in IDT Standard mode.

$\overline{FF}/\overline{IR}$ is synchronous and updated on the rising edge of WCLK. $\overline{FF}/\overline{IR}$ are double register-buffered outputs.

EMPTY FLAG ($\overline{EF}/\overline{OR}$)

This is a dual purpose pin. In the IDT Standard mode, the Empty Flag (\overline{EF}) function is selected. When the SFC is empty, \overline{EF} will go LOW, inhibiting further read operations. When \overline{EF} is HIGH, the SFC is not empty. *Figure 10, Empty Boundary – IDT Standard Mode* for the relevant timing information.

In FWFT mode, the Output Ready (\overline{OR}) function is selected. \overline{OR} goes LOW at the same time that the first word written to an empty SFC appears valid on the outputs. \overline{OR} stays LOW after the RCLK LOW to HIGH transition that shifts the last word from the SFC to the outputs. \overline{OR} goes HIGH only with a true read (RCLK with $\overline{REN} = \text{LOW}$). The previous data stays at the outputs, indicating the last word was read. Further data reads are inhibited until \overline{OR} goes LOW again. See *Figure 11, Empty Boundary (FWFT Mode)*, for the relevant timing information.

$\overline{EF}/\overline{OR}$ is synchronous and updated on the rising edge of RCLK.

In IDT Standard mode, \overline{EF} is a double register-buffered output. In FWFT mode, \overline{OR} is a triple register-buffered output.

PROGRAMMABLE ALMOST-FULL FLAG (\overline{PAF})

The Programmable Almost-Full flag (\overline{PAF}) will go LOW when the SFC reaches the almost-full condition. In IDT Standard mode, if no reads are performed after reset (\overline{MRS}), \overline{PAF} will go LOW after (D - m) words are written to the SFC. See *Figure 22, Synchronous \overline{PAF} Flag - IDT Standard Mode and FWFT Mode*, for the relevant timing information.

If asynchronous \overline{PAF} configuration is selected, the \overline{PAF} is asserted LOW on the LOW-to-HIGH transition of the Write Clock (WCLK). \overline{PAF} is reset to HIGH on the LOW-to-HIGH transition of the Read Clock (RCLK). If synchronous \overline{PAF} configuration is selected, the \overline{PAF} is updated on the rising edge of WCLK.

PROGRAMMABLE ALMOST-EMPTY FLAG (\overline{PAE})

The Programmable Almost-Empty flag (\overline{PAE}) will go LOW when the SFC reaches the almost-empty condition. In IDT Standard mode, \overline{PAE} will go LOW when there are n words or less in the SFC. The offset "n" is the empty offset value. The default setting for this value is in Table 10, Device Configuration.

In FWFT mode, the \overline{PAE} will go LOW when there are n+1 words or less in the SFC. See *Figure 21, Synchronous \overline{PAE} Flag - IDT Standard Mode and FWFT Mode*, for the relevant timing information.

If asynchronous \overline{PAE} configuration is selected, the \overline{PAE} is asserted LOW on the LOW-to-HIGH transition of the Read Clock (RCLK). \overline{PAE} is reset to HIGH on the LOW-to-HIGH transition of the Write Clock (WCLK). If synchronous \overline{PAE} configuration is selected, the \overline{PAE} is updated on the rising edge of RCLK.

DATA OUTPUTS (Q0-Q35)

(Q0-Q35) are data outputs for 36-bit wide data, (Q0 - Q17) are data outputs for 18-bit wide data or (Q0-Q8) are data outputs for 9-bit wide data.

MEMORY CLOCK OUTPUT (CK)

These signals are to be connected to the external DDR SDRAM's clock input.

MEMORY CLOCK OUTPUT INVERTED (\overline{CK})

These signals are to be connected to the external DDR SDRAM's differential clock input.

MEMORY BANK ADDRESS INPUT BIT (BA[1:0])

These signals are to be connected to the external DDR SDRAM's bank address input bits.

MEMORY COLUMN ADDRESS STROBE (\overline{CAS})

These signals are to be connected to the external DDR SDRAM's column address strobe input.

MEMORY ADDRESS BUS (A[12:0])

These signals are to be connected to the external DDR SDRAM's address bus.

MEMORY WRITE ENABLE (\overline{WE})

These signals are to be connected to the external DDR SDRAM's write enable.

MEMORY ROW ADDRESS STROBE (\overline{RAS})

These signals are to be connected to the external DDR SDRAM's row address strobe input.

BI-DIRECTIONAL I/O

MEMORY DATA INPUTS/OUTPUTS DQ[63:0]

These signals are to be connected to the external DDR SDRAM's data input bus.

MEMORY DATA STROBE OUTPUT DQS[7:0]

These signals are to be connected to the external DDR SDRAM's data strobe inputs.

ABSOLUTE MAXIMUM RATINGS

Symbol	Rating	Com'l & Ind'l	Unit
VTERM	Terminal Voltage with respect to GND	-0.5 to +3.6 ⁽²⁾	V
TSTG	Storage Temperature	-55 to +125	°C
TJMAX	Maximum Junction Temp.	150	°C
IOUT	DC Output Current	-50 to +50	mA

NOTES:

- Stresses greater than those listed under ABSOLUTE MAXIMUM RATINGS may cause permanent damage to the device. This is a stress rating only and functional operation of the device at these or any other conditions above those indicated in the operational sections of this specification is not implied. Exposure to absolute maximum rating conditions for extended periods may affect reliability.
- Compliant with JEDEC JESD8-5. VCC terminal only.

CAPACITANCE (TA = +25°C, f = 1.0MHz)

Symbol	Parameter ⁽¹⁾	Conditions	Max.	Unit
CIN ^(2,3)	Input Capacitance	VIN = 0V	10 ⁽³⁾	pF
COU ^(1,2)	Output Capacitance	VOUT = 0V	10	pF

NOTES:

- With output deselected, ($\overline{OE} \geq V_{IH}$).
- Characterized values, not currently tested.
- CIN for Vref is 20pF.

PACKAGE THERMAL DATA

Symbol	Parameter	Industrial/ Commercial	Unit
θ_{JC}	Junction to case thermal resistance	3.8	C/W
θ_{JA}	Junction to air thermal resistance airflow @ 0m/s @ 1m/s @ 2m/s @ 3m/s @ 4m/s @ 5m/s	27.4 22.8 20.3 19.5 18.2 17.8	C/W
MSL	Moisture sensitivity level	3	

RECOMMENDED DC OPERATING CONDITIONS

Symbol	Parameter	Min.	Typ.	Max.	Unit
VCC	Supply Voltage	2.375	2.5	2.625	V
AVCC	Analog Supply Voltage	2.375	2.5	2.625	V
VDDQ	Output Rail Voltage for I/Os	2.375	—	3.45	V
GND	Supply Ground	0	0	0	V
VREF ⁽¹⁾	SSTL_2 Voltage Reference Input	1.13	1.25	1.38	V
TA	Operating Temperature (Commercial)	0	—	70	°C
TA	Operating Temperature (Industrial)	-40	—	85	°C

NOTE:

- Typically the value of VREF is expected to be (0.49-0.51) x VCC.

DC ELECTRICAL CHARACTERISTICS

(Commercial: $V_{CC} = 2.5V \pm 0.125V$, $T_A = 0^{\circ}C$ to $+70^{\circ}C$; Industrial: $V_{CC} = 2.5V \pm 0.125V$, $T_A = -40^{\circ}C$ to $+85^{\circ}C$)

I/O Type	Symbol	Parameter	Min.	Max.	Unit	
SFC Input (LVTTTL)	I _{LI}	Input leakage current	-10	10	μA	
	V _{IH}	Input High Voltage	V _{DDQ} = 3.3V	2.0	5.5	V
			V _{DDQ} = 2.5V	1.7	3.45	V
V _{IL}	Input Low Voltage	V _{DDQ} = 3.3V	—	0.8	V	
		V _{DDQ} = 2.5V	-0.3	0.7	V	
SFC Output (LVTTTL)	I _{LO}	Output leakage current	-10	10	μA	
	V _{OH}	Read/Write interface output logic "1" voltage with I _{OH1}	V _{DDQ} = 3.3V	V _{DDQ} - 0.4	—	V
			V _{DDQ} = 2.5V	V _{DDQ} - 0.4	—	V
	V _{OL}	Read/Write interface output logic "0" voltage with I _{OL1}	V _{DDQ} = 3.3V	—	0.4	V
			V _{DDQ} = 2.5V	—	0.4	V
	I _{OH}	Read/Write interface output high current (source current)	V _{DDQ} = 3.3V	-2	—	mA
V _{DDQ} = 2.5V			-8	—	mA	
I _{OL}	Read/Write interface output low current (sink current)	V _{DDQ} = 3.3V	8	—	mA	
		V _{DDQ} = 2.5V	8	—	mA	
DDR SDRAM I/O (SSTL_2) ⁽¹⁾	I _{OH}	Memory interface output high current (source current)	-7.6	—	mA	
	I _{OL}	Memory interface output low current (sink current)	7.6	—	mA	
	V _{IH}	Memory Interface Input High Voltage	1.7	3.0	V	
	V _{IL}	Memory Interface Input Low Voltage	-0.3	0.7	V	
	V _{OH}	Memory Interface Output High Voltage	1.5	—	V	
	V _{OL}	Memory Interface Output Low Voltage	—	1.00	V	

POWER CONSUMPTION

Symbol	Parameter	Min.	Max.	Unit
I _{CC1} ⁽²⁾	Active V _{CC} current	—	650	mA
I _{CC2} ⁽²⁾	Active AV _{CC} current	—	18	mA
I _{CC3} ⁽²⁾	Active V _{DDQ} current	—	1	mA
I _{SB1} ⁽³⁾	Standby V _{CC} current	—	600	mA
I _{SB2} ⁽³⁾	Standby V _{DDQ} current	—	1	mA

General DC Test Conditions

- Measurements taken with $V_{CC} = 2.625V$, $\overline{OE} = \text{HIGH}$, $WCLK = RCLK = 16.7\text{MHz}$, $MCLK = 33.3\text{MHz}$
- Data toggles alternately at 1/2 WCLK and RCLK frequency
- $0.4 \leq V_{IN} \leq V_{CC}$, $0.4 \leq V_{OUT} \leq V_{CC}$
- Outputs are unloaded ($I_{OUT} = 0$)

NOTES:

1. These parameters are compliant under JEDEC standard for SSTL_2 (JESD8-9A). These parameters are classified as SSTL_2 Class I output buffers under section 3.2.1 of JESD8-9A.
2. ICC (active current) is measured with $MCLK = 33.3\text{MHz}$, $RCLK = WCLK = 16.7\text{MHz}$, and alternate 101010 data pattern toggling on the outputs.
3. ISB (standby current) is measured with $MCLK = RCLK = WCLK = 0\text{MHz}$ with no output data toggling.
4. V_{SDREF} is the V_{REF} of the DDR SDRAM. It is not to be confused with the V_{REF} of the SFC.
5. The maximum value may not represent the maximum current dissipated from the SFC. ICC values are dependent upon various factors that include: V_{CC}, temperature, capacitive load, frequency, bus-width, and output switching characteristics. For calculating ICC with specific parameters, please contact IDT technical support for assistance.

AC TEST CONDITIONS

2.5V LVTTTL AC TEST CONDITIONS

Input Pulse Levels	GND to 2.5V
Input Rise/Fall Times	1ns
Input Timing Reference Levels	1.25V
Output Reference Levels	1.25V

2.5V SSTL AC TEST CONDITIONS

Input Pulse Levels	GND to 2.5V
Input Rise/Fall Times	1ns
Input Timing Reference Levels	1.25V
Output Reference Levels	1.25V

3.3V LVTTTL AC TEST CONDITIONS

Input Pulse Levels	GND to 3.0V
Input Rise/Fall Times	3ns
Input Timing Reference Levels	1.5V
Output Reference Levels	1.5V

AC TEST LOADS

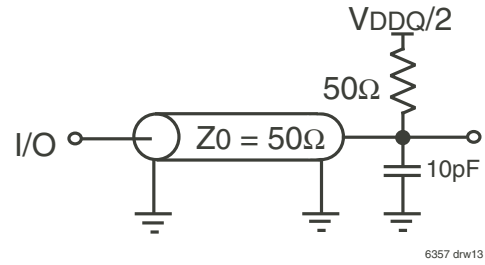

Figure 5a. AC Test Load

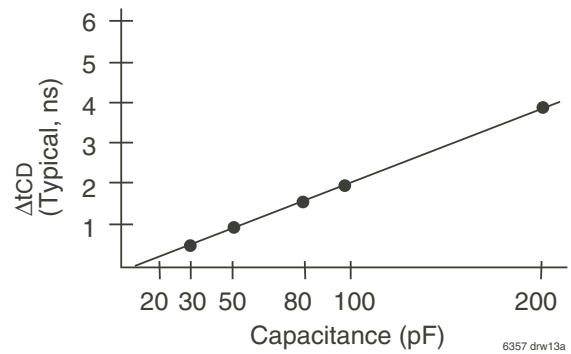

Figure 5b. Lumped Capacitive Load, Typical Derating

AC ELECTRICAL CHARACTERISTICS⁽¹⁾ — SYNCHRONOUS TIMING

(Commercial: VCC = 2.5V ± 5%, TA = 0°C to +70°C; Industrial: VCC = 2.5V ± 5%, TA = -40°C to +85°C)

Symbol	Parameter	Commercial		Com'l & Ind'l ⁽²⁾		Unit
		IDT72T6360L6		IDT72T6360L7-5		
		Min.	Max.	Min.	Max.	
f _s	Synchronous Clock Cycle Frequency	—	166	—	133	MHz
t _A	Data Access Time	1	4	1	5	ns
t _{CLK}	Clock Cycle Time	6	—	7.5	—	ns
t _{CLKH}	Clock High Time	2.7	—	3.5	—	ns
t _{CLKL}	Clock Low Time	2.7	—	3.5	—	ns
t _{DS}	Data Setup Time	2	—	2.5	—	ns
t _{DH}	Data Hold Time	0.5	—	0.5	—	ns
t _{ENS}	Enable Setup Time	2	—	2.5	—	ns
t _{ENH}	Enable Hold Time	0.5	—	0.5	—	ns
t _{RS}	Reset Pulse Width	10	—	10	—	ns
t _{RSU}	Reset Setup Time	15	—	15	—	ns
t _{RSH}	Reset Hold Time	10	—	10	—	ns
t _{PL}	Reset to PLL Lock	20	—	20	—	μs
t _{RSF}	Reset to Flag and Output	—	15	—	15	ns
t _{OHZ}	Output enable to High-Z	1	4	1	5	ns
t _{OE}	Output Enable Valid	1	4	1	5	ns
f _{MC}	Master Clock Cycle Frequency	32	34	32	34	MHz
t _{MCYC}	Master Clock Cycle Time	29.4	31.3	29.4	31.3	ns
t _{MCKH}	Master Clock Cycle HIGH	0.45	0.55	0.45	0.55	t _{MCYC}
t _{MCKL}	Master Clock Cycle LOW	0.45	0.55	0.45	0.55	t _{MCYC}
f _{SC}	Serial Clock Cycle Frequency	—	10	—	10	MHz
t _{SCLK}	Serial Clock Cycle	100	—	100	—	ns
t _{SCLKH}	Serial Clock HIGH	45	—	45	—	ns
t _{SCLKL}	Serial Clock LOW	45	—	45	—	ns
t _{SDS}	Serial Data Setup	15	—	15	—	ns
t _{SDH}	Serial Data Hold	5	—	5	—	ns
t _{SENS}	Serial Enable Setup	5	—	5	—	ns
t _{SENH}	Serial Enable Hold	5	—	5	—	ns
t _{ASO}	Serial Output Data Access Time	—	20	—	20	ns
t _{WFFs}	Write Clock to Synchronous $\overline{FF}/\overline{IR}$	—	4	—	5	ns
t _{REFs}	Read Clock to Synchronous $\overline{EF}/\overline{OR}$	—	4	—	5	ns
t _{PAFs}	WCLK to Synchronous \overline{PAF}	—	4	—	5	ns
t _{PAEs}	RCLK to Synchronous \overline{PAE}	—	4	—	5	ns
t _{SKEW1}	Skew time between RCLK and WCLK for $\overline{EF}/\overline{OR}$ and $\overline{FF}/\overline{IR}$ in SDR	4	—	5	—	ns
t _{SKEW2}	Skew time between RCLK and WCLK for $\overline{PAE}/\overline{PAF}$	5	—	7	—	ns
t _{WCSS}	\overline{WCS} Setup Time	2	—	2.5	—	ns
t _{WCSH}	\overline{WCS} Hold Time	0.5	—	0.5	—	ns
f _{c1}	Memory Clock Cycle Frequency at 166MHz	160	170	—	—	MHz
f _{c2}	Memory Clock Cycle Frequency at 133MHz	128	136	128	136	MHz
t _{CK1}	Memory Clock Cycle Time at 166MHz	6.2	5.9	—	—	ns
t _{CK2}	Memory Clock Cycle Time at 133MHz	7.8	7.3	7.8	7.3	ns
t _{CKH1}	Memory Clock Cycle HIGH at 166MHz	0.45	0.55	—	—	t _{CK1}
t _{CKH2}	Memory Clock Cycle HIGH at 133MHz	0.45	0.55	0.45	0.55	t _{CK2}
t _{CKL1}	Memory Clock Cycle LOW at 166MHz	0.45	0.55	—	—	t _{CK1}
t _{CKL2}	Memory Clock Cycle LOW at 133MHz	0.45	0.55	0.45	0.55	t _{CK2}

NOTES:

1. All AC timings apply to both Standard IDT mode and First Word Fall Through mode.
2. Industrial temperature range product for the 7.5ns speed grade is available as a standard device. All other speed grades are available by special order.

AC ELECTRICAL CHARACTERISTICS—ASYNCHRONOUS TIMING

(Commercial: $V_{CC} = 2.5V \pm 5\%$, $T_A = 0^{\circ}C$ to $+70^{\circ}C$; Industrial: $V_{CC} = 2.5V \pm 5\%$, $T_A = -40^{\circ}C$ to $+85^{\circ}C$)

Symbol	Parameter	Commercial		Com'l & Ind'l ⁽²⁾		Unit
		IDT72T6360L6		IDT72T6360L7-5		
		Min.	Max.	Min.	Max.	
f _A	Asynchronous Clock Cycle Frequency	—	100	—	83	MHz
t _{Aa}	Data Access Time	0.6	8	0.6	10	ns
t _{CYC}	Cycle Time	10	—	12	—	ns
t _{CYCH}	Cycle HIGH Time	4.5	—	5	—	ns
t _{CYCL}	Cycle LOW Time	4.5	—	5	—	ns
t _{FFa}	Rising Edge to \overline{FF}	—	8	—	10	ns
t _{EFa}	Rising Edge to \overline{EF}	—	8	—	10	ns
t _{PAFa}	Rising Edge to \overline{PAF}	—	8	—	10	ns
t _{PAEa}	Rising Edge to \overline{PAE}	—	8	—	10	ns
t _{RPE}	Read Pulse after \overline{EF} HIGH	8	—	10	—	ns

NOTES:

1. All AC timings apply to both Standard IDT mode and First Word Fall Through mode.
2. Industrial temperature range product for the 7.5ns speed grade is available as a standard device. All other speed grades are available by special order.

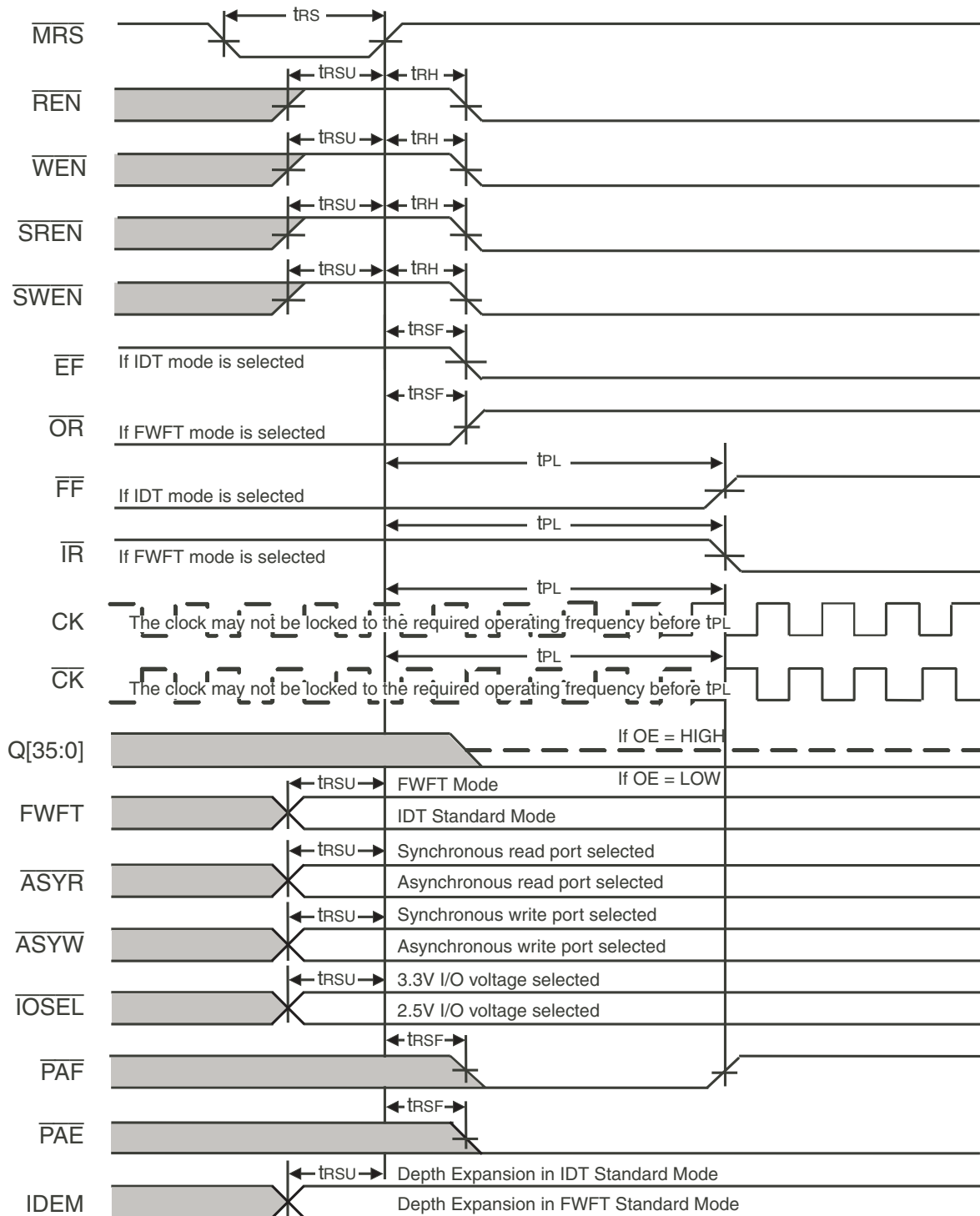

6357 drw20

NOTE:

1. For other signals that are latched during master reset, refer to Master Reset and Device Configuration section.

Symbol	Parameter	Min.	Max.	Unit
t_{RS}	Reset Pulse Width	10	—	ns
t_{RSU}	Reset Setup Time	15	—	ns
t_{RSH}	Reset Hold Time	10	—	ns
t_{PL}	Reset to PLL Lock	20	—	μ s
t_{RSF}	Reset to Flag and Output	—	15	ns

Figure 6. Master Reset and Initialization

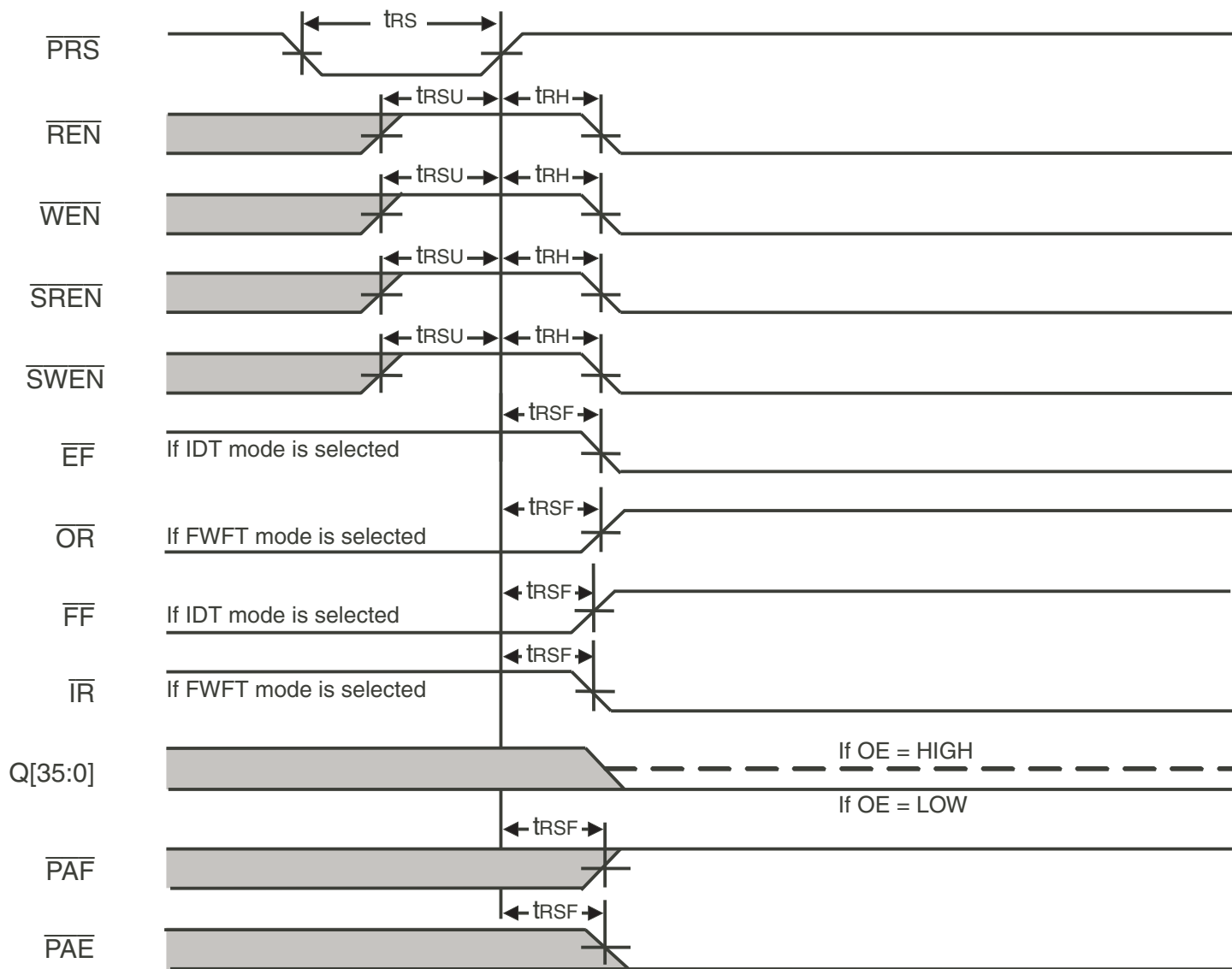

6357 drw21

Symbol	Parameter	Min.	Max.	Unit
t_{RS}	Reset Pulse Width	10	—	ns
t_{RSU}	Reset Setup Time	15	—	ns
t_{RSH}	Reset Hold Time	10	—	ns
t_{PL}	Reset to PLL Lock	20	—	μ s
t_{RSF}	Reset to Flag and Output	—	15	ns

Figure 7. Partial Reset

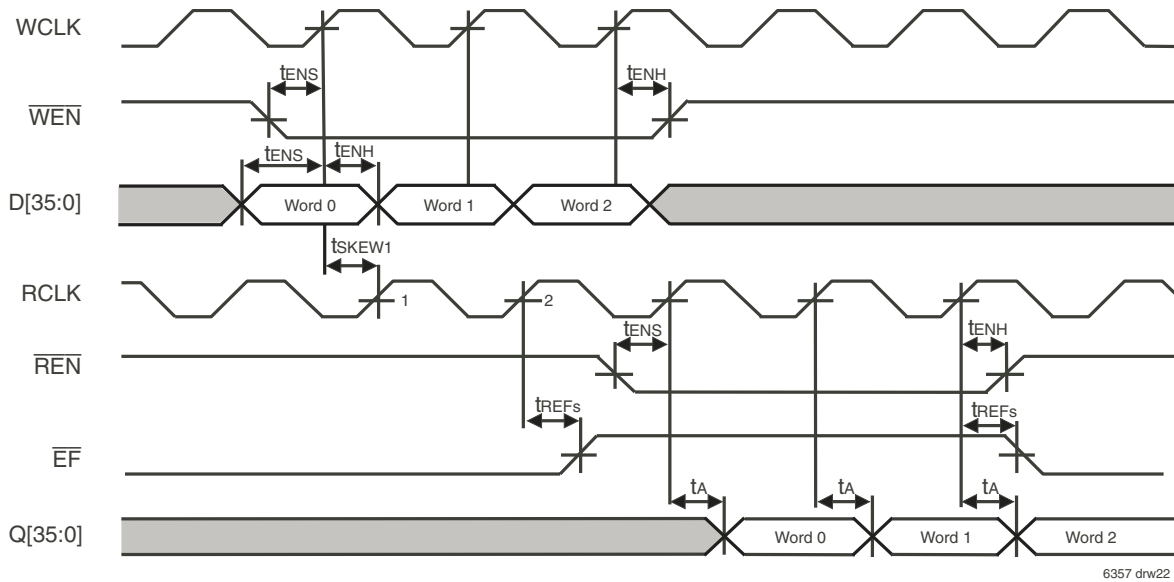

NOTES:

1. t_{SKEW1} is the minimum time between a rising WCLK edge and a rising RCLK edge to guarantee that \overline{EF} will go HIGH after one RCLK cycle (plus t_{REFs}). If t_{SKEW1} is not met, then \overline{EF} de-assertion may be delayed one extra RCLK cycle.
2. Settings: $\overline{OE} = \text{LOW}$, $\overline{RCS} = \text{LOW}$, $\overline{WCS} = \text{LOW}$, $\text{BM}[3:0] = 1000$, $\text{FWFT} = \text{LOW}$, $\overline{ASYR} = \text{HIGH}$, and $\overline{ASYW} = \text{HIGH}$.

Figure 8. Write First Word Cycles - IDT Standard Mode

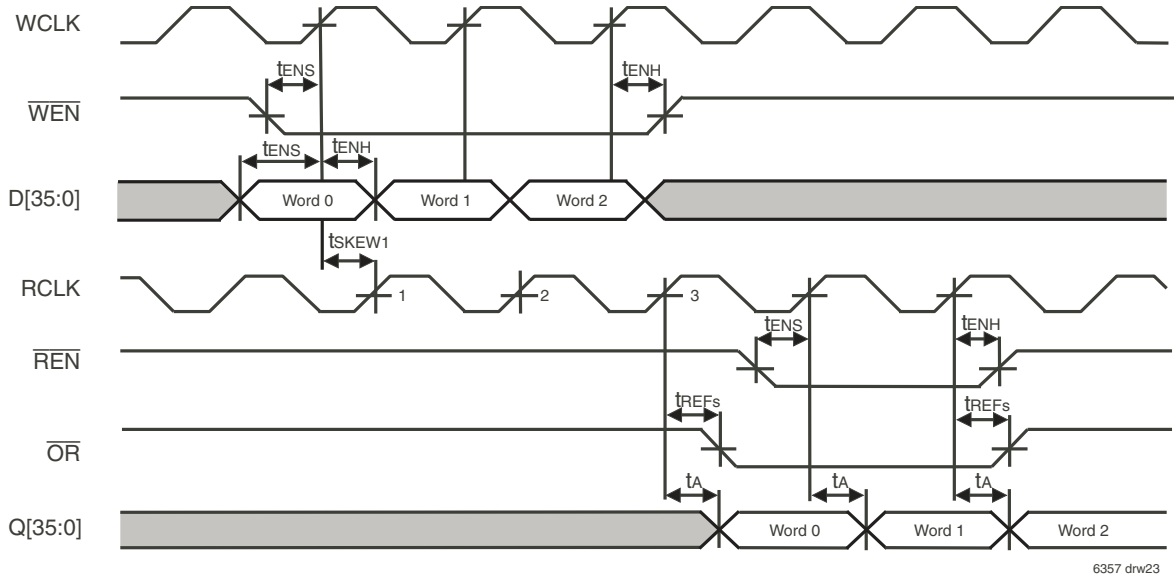

NOTES:

1. t_{SKEW1} is the minimum time between a rising WCLK edge and a rising RCLK edge to guarantee that \overline{EF} will go HIGH after one RCLK cycle (plus t_{REFs}). If t_{SKEW1} is not met, then \overline{EF} de-assertion may be delayed one extra RCLK cycle.
2. Settings: $\overline{OE} = \text{LOW}$, $\overline{RCS} = \text{LOW}$, $\overline{WCS} = \text{LOW}$, $\text{BM}[3:0] = 1000$, $\text{FWFT} = \text{HIGH}$, $\overline{ASYR} = \text{HIGH}$, and $\overline{ASYW} = \text{HIGH}$.

Figure 9. Write First Word Cycles - FWFT Mode

Symbol	Parameter	6ns		7-5ns		Unit
		Min.	Max.	Min.	Max.	
t_{SENS}	Serial Enable Setup	5	—	5	—	ns
t_{SENH}	Serial Enable Hold	5	—	5	—	ns
t_A	Data Access Time	1	4	1	5	ns
t_{SKEW1}	Skew time between RCLK and WCLK for $\overline{EF}/\overline{OR}$ and $\overline{FF}/\overline{IR}$ in SDR	4	—	5	—	ns
t_{REFs}	Read Clock to Synchronous $\overline{EF}/\overline{OR}$	—	4	—	5	ns

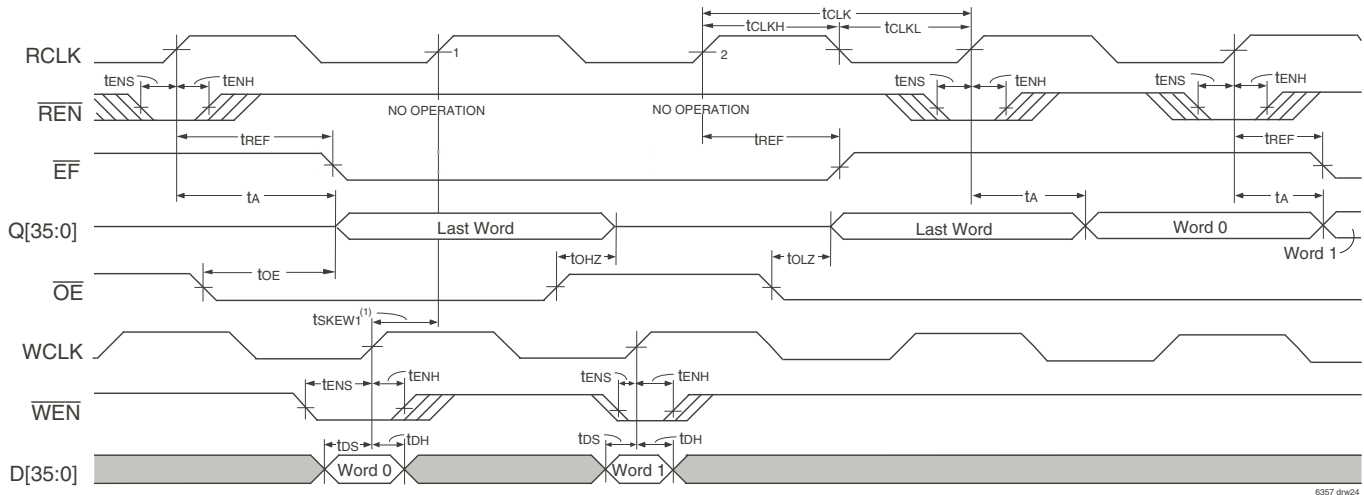

NOTES:

1. tSKEW1 is the minimum time between a rising WCLK edge and a rising RCLK edge to guarantee that \overline{EF} will go HIGH after one RCLK cycle (plus tREFs). If tSKEW1 is not met, then \overline{EF} de-assertion may be delayed one extra RCLK cycle.
2. Settings: \overline{RCS} = LOW, \overline{WCS} = LOW, $BM[3:0]$ = 1000, $FWFT$ = LOW, \overline{ASYR} = HIGH, and \overline{ASYW} = HIGH.

Figure 10. Empty Boundary - IDT Standard Mode

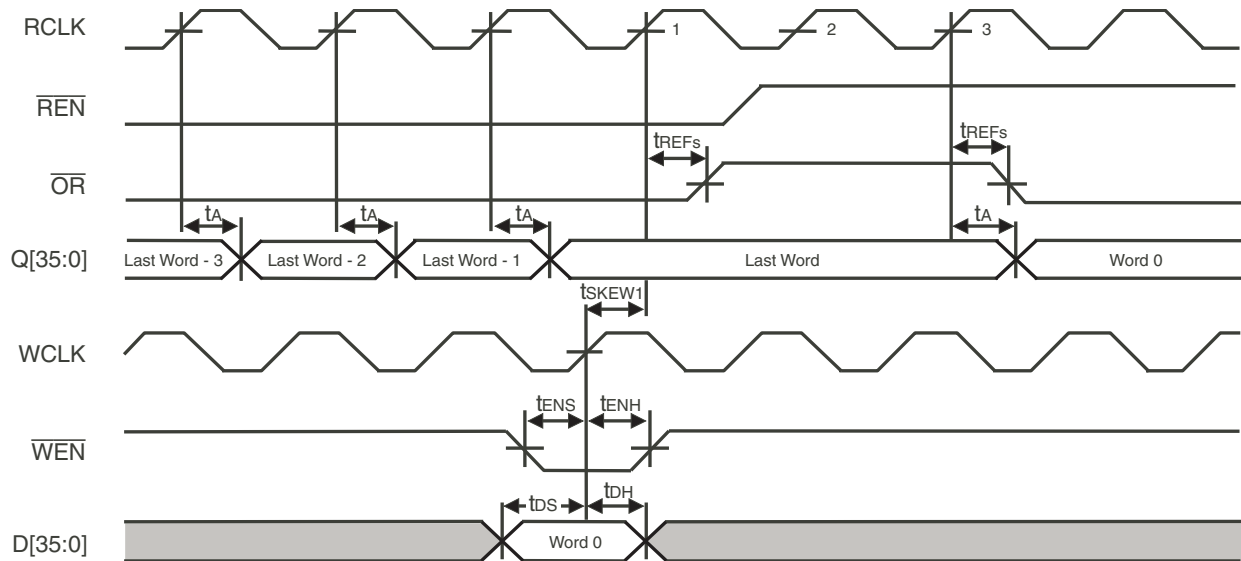

NOTES:

1. tSKEW1 is the minimum time between a rising WCLK edge and a rising RCLK edge to guarantee that \overline{EF} will go HIGH after one RCLK cycle (plus tREFs). If tSKEW1 is not met, then \overline{EF} de-assertion may be delayed one extra RCLK cycle.
2. Settings: \overline{OE} = LOW, \overline{RCS} = LOW, \overline{WCS} = LOW, $BM[3:0]$ = 1000, $FWFT$ = HIGH, \overline{ASYR} = HIGH, and \overline{ASYW} = HIGH.

Figure 11. Empty Boundary - FWFT Mode

Symbol	Parameter	6ns		7.5ns		Unit
		Min.	Max.	Min.	Max.	
tCLK	Clock Cycle Time	6	—	7.5	—	ns
tCLKH	Clock High Time	2.7	—	3.5	—	ns
tCLKL	Clock Low Time	2.7	—	3.5	—	ns
tDS	Data Setup Time	2	—	2.5	—	ns
tDH	Data Hold Time	0.5	—	0.5	—	ns
tENS	Enable Setup Time	2	—	2.5	—	ns
tENH	Enable Hold Time	0.5	—	0.5	—	ns
tA	Data Access Time	1	4	1	5	ns
tREFs	Read Clock to Synchronous $\overline{EF}/\overline{OR}$	—	4	—	5	ns
tSKEW1	Skew time between RCLK and WCLK for $\overline{EF}/\overline{OR}$ and $\overline{FF}/\overline{IR}$ in SDR	4	—	5	—	ns

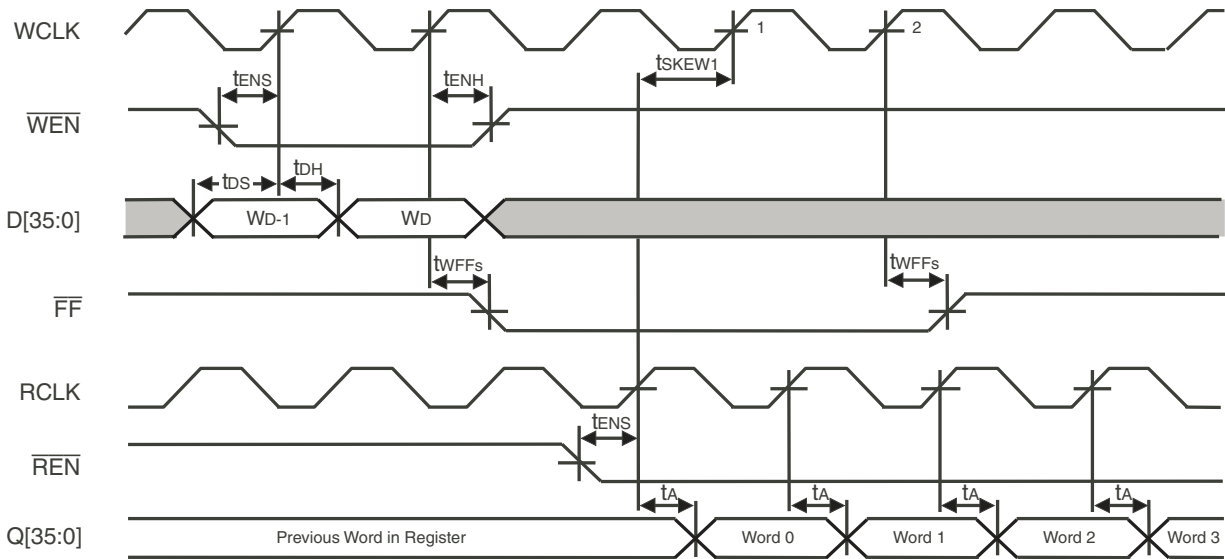

NOTES: 6357 drw26

1. tSKEW1 is the minimum time between a rising RCLK edge and a rising WCLK edge to guarantee that \overline{FF} will go HIGH after one WCLK cycle (plus tWFFs). If tSKEW1 is not met, then \overline{FF} de-assertion may be delayed one extra WCLK cycle.
2. Settings: \overline{OE} = LOW, \overline{RCS} = LOW, \overline{WCS} = LOW, BM[3:0] = 1000, FWFT = LOW, \overline{ASYR} = HIGH, and \overline{ASYW} = HIGH.

Figure 12. Full Boundary - IDT Standard Mode

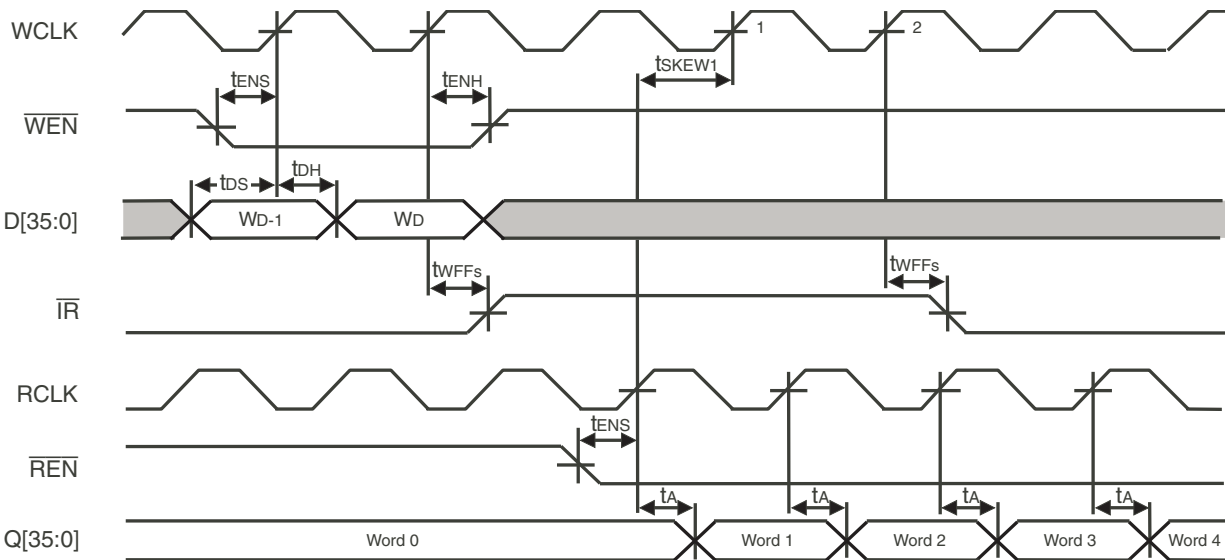

NOTES: 6357 drw27

1. tSKEW1 is the minimum time between a rising WCLK edge and a rising RCLK edge to guarantee that \overline{EF} will go HIGH after one RCLK cycle (plus tREFs). If tSKEW1 is not met, then \overline{EF} de-assertion may be delayed one extra RCLK cycle.
2. Settings: \overline{RCS} = LOW, \overline{WCS} = LOW, BM[3:0] = 1000, FWFT = HIGH, \overline{ASYR} = HIGH, and \overline{ASYW} = HIGH.

Figure 13. Full Boundary - FWFT Mode

Symbol	Parameter	6ns		7-5ns		Unit
		Min.	Max.	Min.	Max.	
tDS	Data Setup Time	2	—	2.5	—	ns
tDH	Data Hold Time	0.5	—	0.5	—	ns
tENS	Enable Setup Time	2	—	2.5	—	ns
tENH	Enable Hold Time	0.5	—	0.5	—	ns
tA	Data Access Time	1	4	1	5	ns
tWFFs	Write Clock to Synchronous $\overline{FF}/\overline{IR}$	—	4	—	5	ns
tSKEW1	Skew time between RCLK and WCLK for $\overline{EF}/\overline{OR}$ and $\overline{FF}/\overline{IR}$ in SDR	4	—	5	—	ns

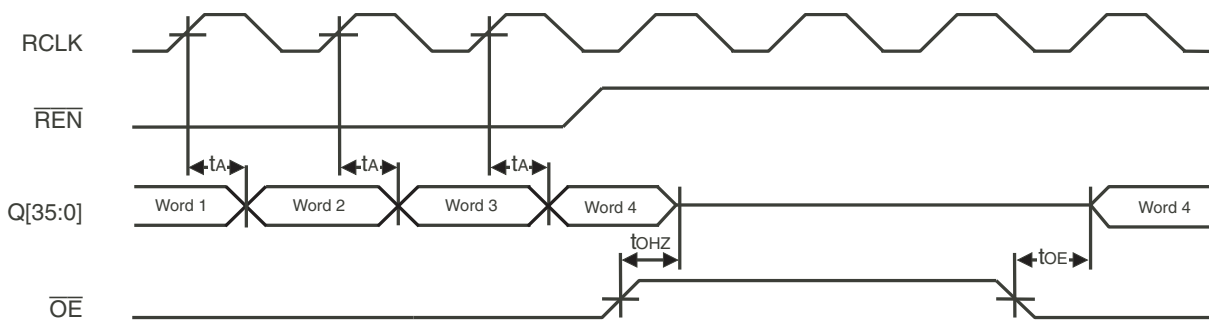

6357 drw28

NOTE:

1. Settings: $\overline{RCS} = \text{LOW}$, $\text{BM}[3:0] = 1000$, $\text{FWFT} = \text{LOW}$, $\overline{\text{ASYR}} = \text{HIGH}$, and $\overline{\text{ASYW}} = \text{HIGH}$.

Figure 14. Output Enable

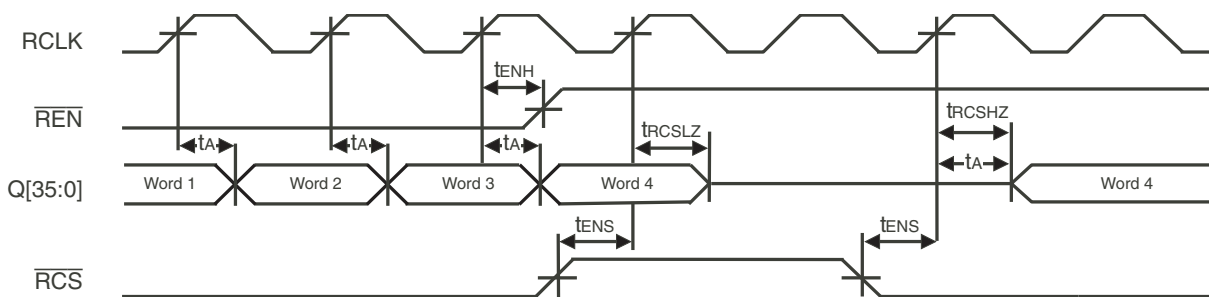

6357 drw29

NOTE:

1. Settings: $\overline{\text{OE}} = \text{LOW}$, $\text{BM}[3:0] = 1000$, $\text{FWFT} = \text{LOW}$, $\overline{\text{ASYR}} = \text{HIGH}$, and $\overline{\text{ASYW}} = \text{HIGH}$.

Figure 15. Read Chip Select

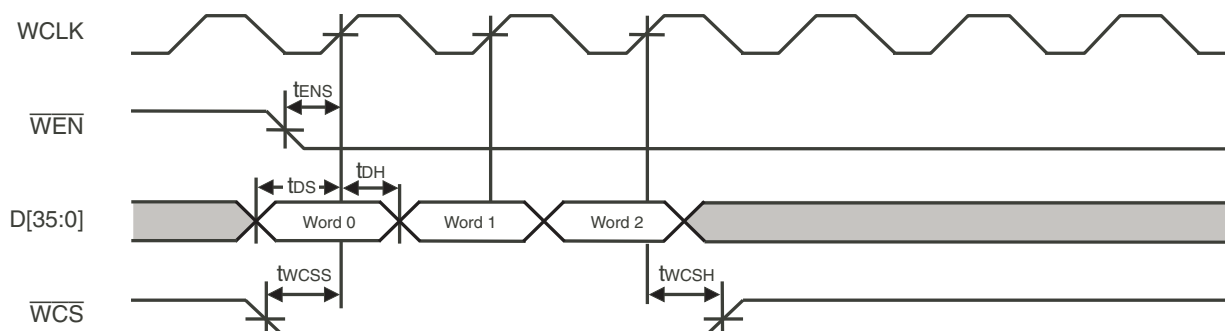

6357 drw30

NOTE:

1. Settings: $\text{BM}[3:0] = 1000$, $\text{FWFT} = \text{LOW}$, $\overline{\text{ASYR}} = \text{HIGH}$, and $\overline{\text{ASYW}} = \text{HIGH}$.

Figure 16. Write Chip Select

Symbol	Parameter	6ns		7-5ns		Unit
		Min.	Max.	Min.	Max.	
tDS	Data Setup Time	2	—	2.5	—	ns
tDH	Data Hold Time	0.5	—	0.5	—	ns
tENS	Enable Setup Time	2	—	2.5	—	ns
tENH	Enable Hold Time	0.5	—	0.5	—	ns
tA	Data Access Time	1	4	1	5	ns
tOHZ	Output enable to High-Z	1	4	1	5	ns
tOE	Output Enable Valid	1	4	1	5	ns
tWCSS	$\overline{\text{WCS}}$ Setup Time	2	—	2.5	—	ns
tWCSSH	$\overline{\text{WCS}}$ Hold Time	0.5	—	0.5	—	ns

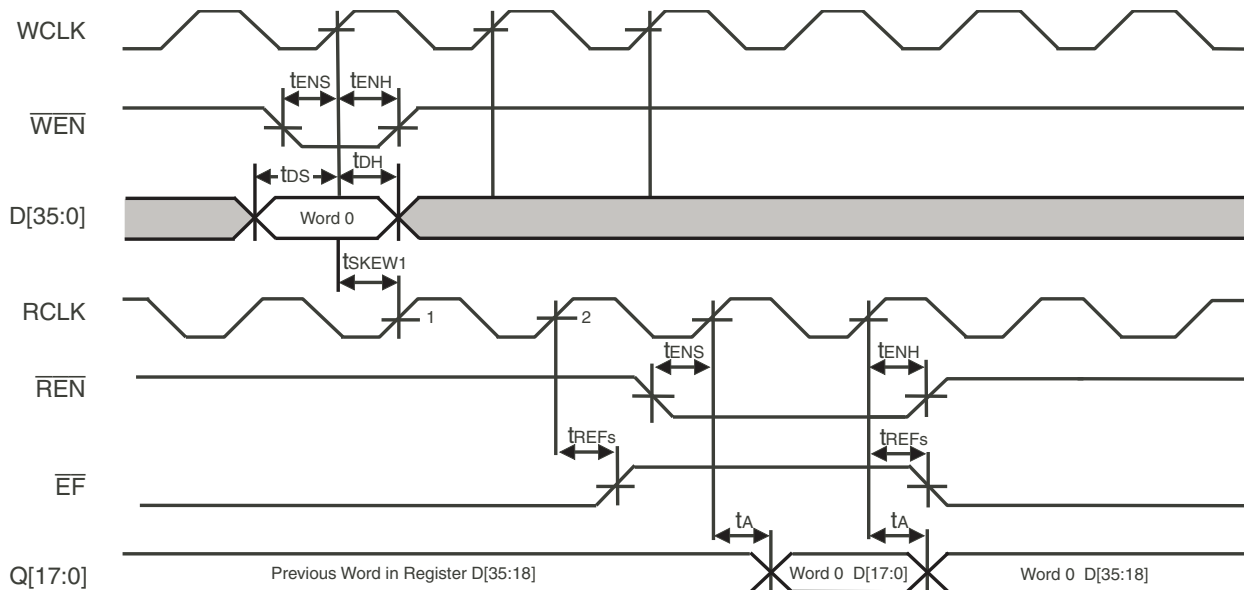

NOTES:

1. tSKEW1 is the minimum time between a rising WCLK edge and a rising RCLK edge to guarantee that \overline{EF} will go HIGH after one RCLK cycle (plus tREFs). If tSKEW1 is not met, then \overline{EF} de-assertion may be delayed one extra RCLK cycle.
2. Settings: \overline{OE} = LOW, \overline{RCS} = LOW, \overline{WCS} = LOW, BM[3:0] = 1011, FWFT = LOW, \overline{ASYR} = HIGH, and \overline{ASYW} = HIGH.

6357 drw31

Figure 17. Bus-Matching Configuration - x36 In to x18 Out - IDT Standard Mode

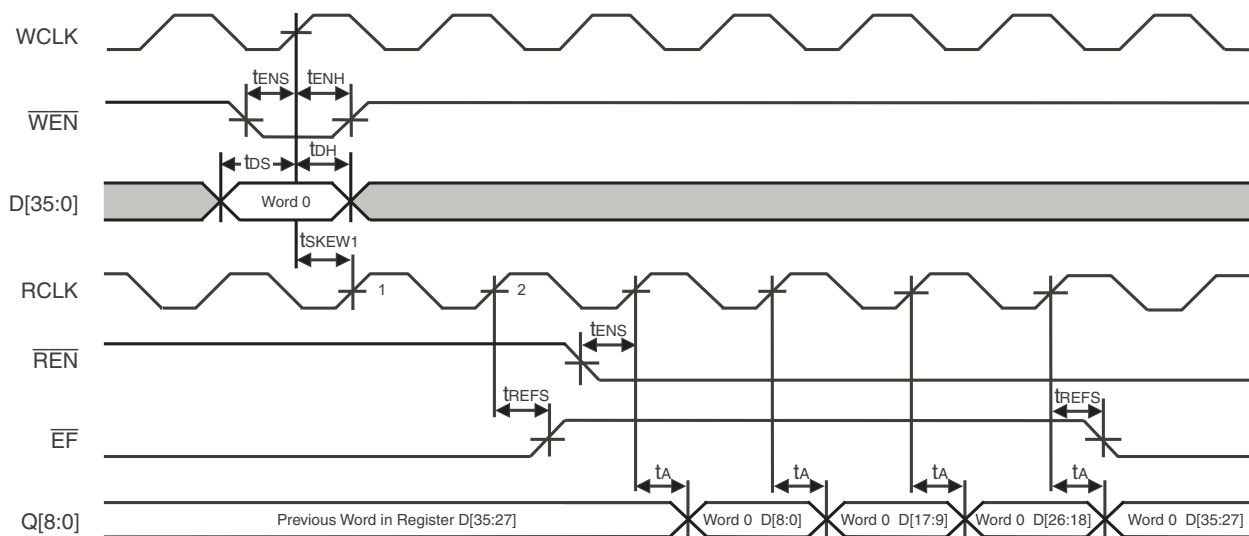

NOTES:

1. tSKEW1 is the minimum time between a rising WCLK edge and a rising RCLK edge to guarantee that \overline{EF} will go HIGH after one RCLK cycle (plus tREFs). If tSKEW1 is not met, then \overline{EF} de-assertion may be delayed one extra RCLK cycle.
2. Settings: \overline{OE} = LOW, \overline{RCS} = LOW, \overline{WCS} = LOW, BM[3:0] = 1111, FWFT = LOW, \overline{ASYR} = HIGH, and \overline{ASYW} = HIGH.

6358 drw32

Figure 18. Bus-Matching Configuration - x36 In to x9 Out - IDT Standard Mode

Symbol	Parameter	6ns		7-5ns		Unit
		Min.	Max.	Min.	Max.	
tDS	Data Setup Time	2	—	2.5	—	ns
tDH	Data Hold Time	0.5	—	0.5	—	ns
tENS	Enable Setup Time	2	—	2.5	—	ns
tENH	Enable Hold Time	0.5	—	0.5	—	ns
tA	Data Access Time	1	4	1	5	ns
tREFs	Read Clock to Synchronous $\overline{EF}/\overline{OR}$	—	4	—	5	ns
tSKEW1	Skew time between RCLK and WCLK for $\overline{EF}/\overline{OR}$ and $\overline{FF}/\overline{IR}$ in SDR	4	—	5	—	ns

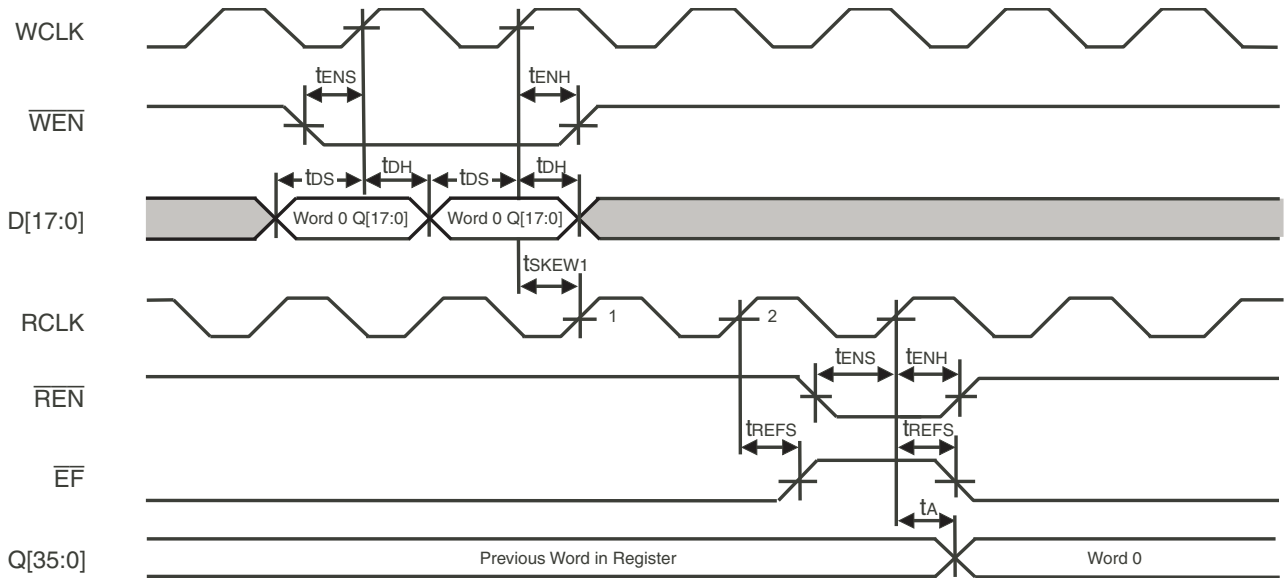

- NOTES:
1. t_{SKEW1} is the minimum time between a rising WCLK edge and a rising RCLK edge to guarantee that \overline{EF} will go HIGH after one RCLK cycle (plus t_{REFS}). If t_{SKEW1} is not met, then \overline{EF} de-assertion may be delayed one extra RCLK cycle.
 2. Settings: $\overline{OE} = \text{LOW}$, $\overline{RCS} = \text{LOW}$, $\overline{WCS} = \text{LOW}$, $BM[3:0] = 1001$, $FWFT = \text{LOW}$, $\overline{ASYR} = \text{HIGH}$, and $\overline{ASYW} = \text{HIGH}$.

Figure 19. Bus-Matching Configuration - x18 In to x36 Out - IDT Standard Mode

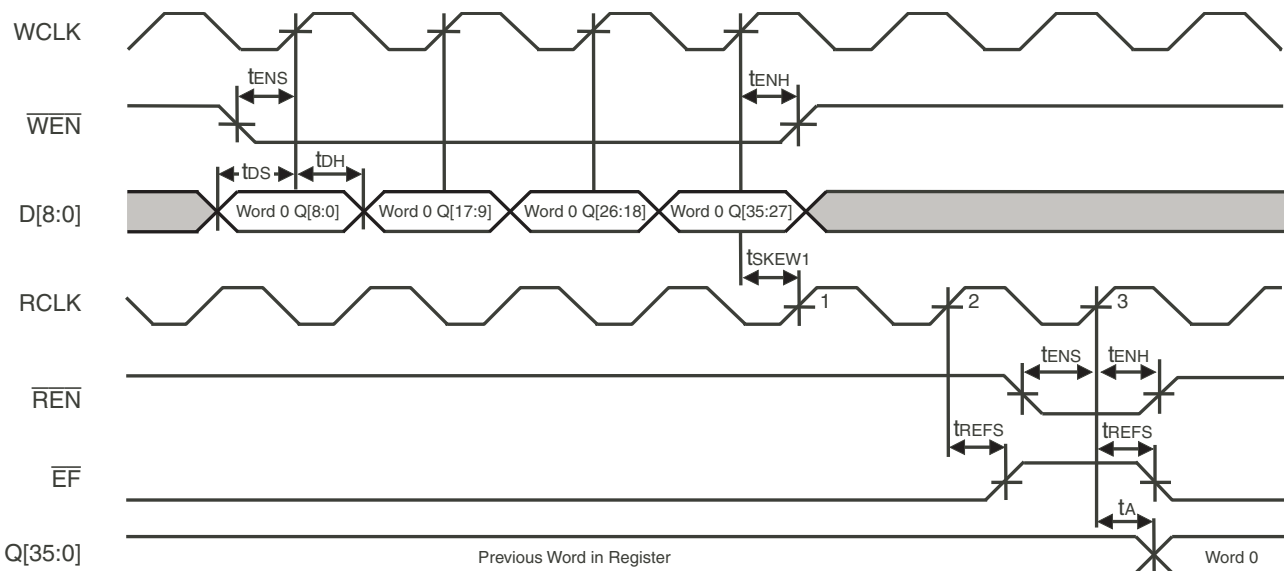

- NOTES:
1. t_{SKEW1} is the minimum time between a rising WCLK edge and a rising RCLK edge to guarantee that \overline{EF} will go HIGH after one RCLK cycle (plus t_{REFS}). If t_{SKEW1} is not met, then \overline{EF} de-assertion may be delayed one extra RCLK cycle.
 2. Settings: $\overline{OE} = \text{LOW}$, $\overline{RCS} = \text{LOW}$, $\overline{WCS} = \text{LOW}$, $BM[3:0] = 1101$, $FWFT = \text{LOW}$, $\overline{ASYR} = \text{HIGH}$, and $\overline{ASYW} = \text{HIGH}$.

Figure 20. Bus-Matching Configuration - x9 In to x36 Out - IDT Standard Mode

Symbol	Parameter	6ns		7-5ns		Unit
		Min.	Max.	Min.	Max.	
t_{DS}	Data Setup Time	2	—	2.5	—	ns
t_{DH}	Data Hold Time	0.5	—	0.5	—	ns
t_{ENS}	Enable Setup Time	2	—	2.5	—	ns
t_{ENH}	Enable Hold Time	0.5	—	0.5	—	ns
t_A	Data Access Time	1	4	1	5	ns
t_{REFS}	Read Clock to Synchronous $\overline{EF}/\overline{OR}$	—	4	—	5	ns
t_{SKEW1}	Skew time between RCLK and WCLK for $\overline{EF}/\overline{OR}$ and $\overline{FF}/\overline{IR}$ in SDR	4	—	5	—	ns

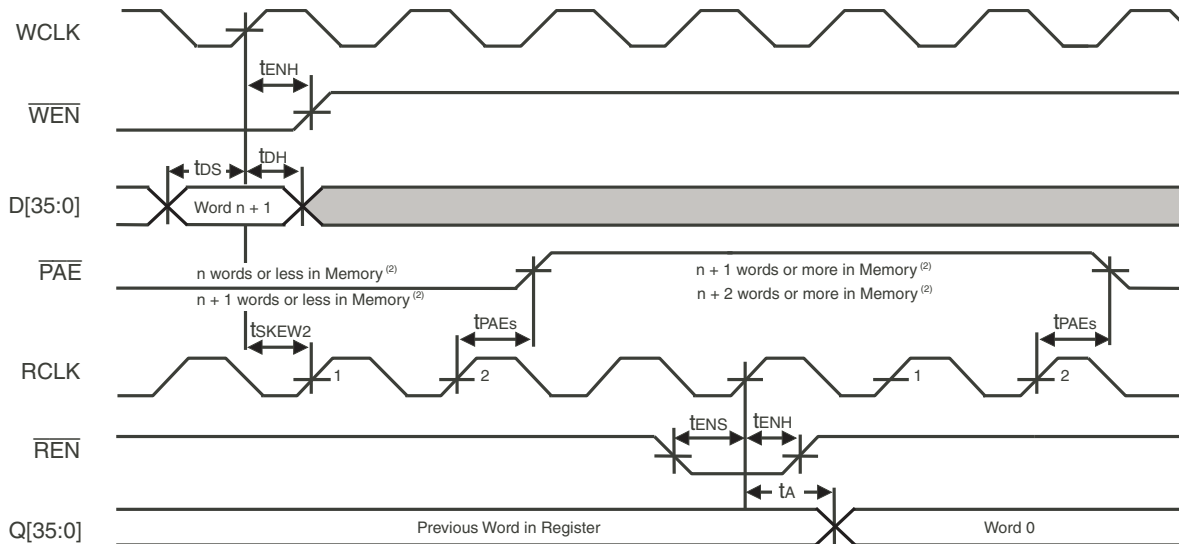

6357 drw35

NOTES:

1. tSKEW2 is the minimum time between a rising WCLK edge and a rising RCLK edge to guarantee that $\overline{\text{PAE}}$ will go HIGH after one RCLK cycle (plus tPAEs). If tSKEW2 is not met, then $\overline{\text{PAE}}$ de-assertion may be delayed one extra RCLK cycle.
2. n = PAE offset, see Table10 for information on setting PAE offset values.
3. Settings: OE = LOW, RCS = LOW, BM[3:0] = 1000, ASYR = HIGH, and ASYW = HIGH.

Figure 21. Synchronous $\overline{\text{PAE}}$ Flag - IDT Standard Mode and FWFT Mode

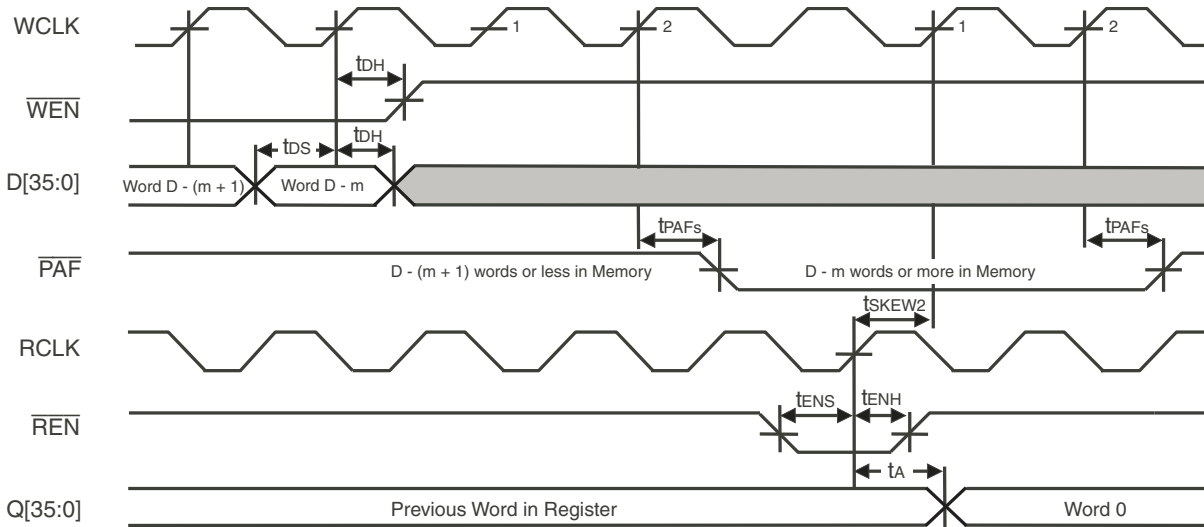

6357 drw36

NOTES:

1. tSKEW2 is the minimum time between a rising WCLK edge and a rising RCLK edge to guarantee that $\overline{\text{PAF}}$ will go HIGH after one RCLK cycle (plus tPAFs). If tSKEW2 is not met, then $\overline{\text{PAF}}$ de-assertion may be delayed one extra RCLK cycle.
2. m = PAF offset, D = density of SFC, see Table10 for information on setting PAF offset values.
3. Settings: OE = LOW, RCS = LOW, BM[3:0] = 1000, ASYR = HIGH, and ASYW = HIGH.

Figure 22. Synchronous $\overline{\text{PAF}}$ Flag - IDT Standard Mode and FWFT Mode

Symbol	Parameter	6ns		7-5ns		Unit
		Min.	Max.	Min.	Max.	
tDS	Data Setup Time	2	—	2.5	—	ns
tDH	Data Hold Time	0.5	—	0.5	—	ns
tENH	Enable Hold Time	0.5	—	0.5	—	ns
tA	Data Access Time	1	4	1	5	ns
tPAFs	WCLK to Synchronous $\overline{\text{PAF}}$	—	4	—	5	ns
tPAEs	RCLK to Synchronous $\overline{\text{PAE}}$	—	4	—	5	ns
tSKEW2	Skew time between RCLK and WCLK for $\overline{\text{PAE/PAF}}$	5	—	7	—	ns

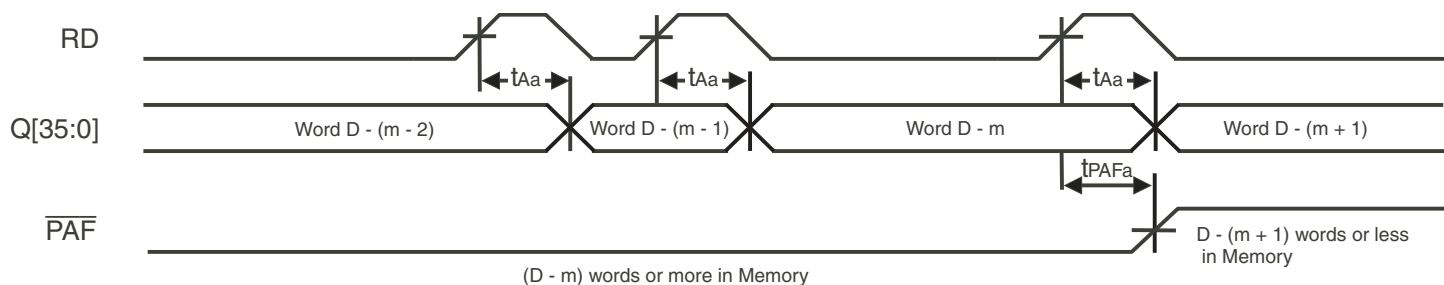

NOTES:

1. $m = \overline{\text{PAF}}$ offset, see Table10 for information on $\overline{\text{PAF}}$ offset values. D = density of SFC.
2. Settings: $\overline{\text{OE}} = \text{LOW}$, $\overline{\text{RCS}} = \text{LOW}$, $\text{BM}[3:0] = 1000$, $\text{FWFT} = \text{LOW}$, $\overline{\text{ASYR}} = \text{LOW}$, and $\overline{\text{ASYW}} = \text{LOW}$.
3. Asynchronous read is available in IDT standard mode only.

6357 drw37

Figure 23. Asynchronous Read and $\overline{\text{PAF}}$ Flag - IDT Standard Mode

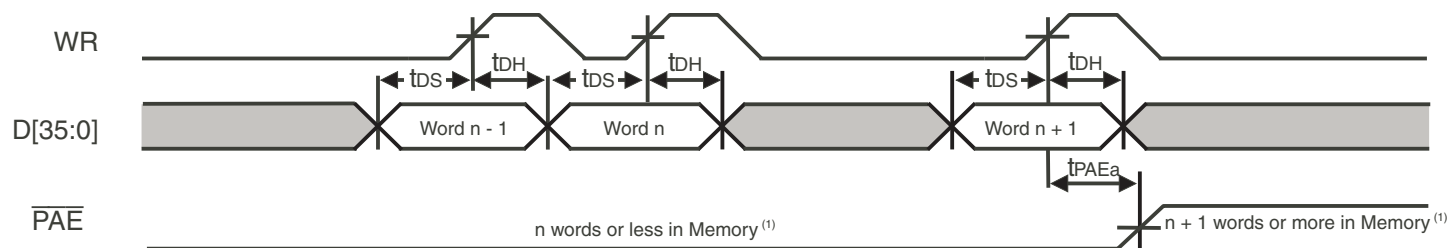

6357 drw38

NOTES:

1. $n = \overline{\text{PAE}}$ offset, see Table10 for information on $\overline{\text{PAE}}$ offset values.
2. Settings: $\overline{\text{WCS}} = \text{LOW}$, $\text{BM}[3:0] = 1000$, $\text{FWFT} = \text{LOW}$, $\overline{\text{ASYR}} = \text{LOW}$, and $\overline{\text{ASYW}} = \text{LOW}$.
3. Asynchronous read is available in IDT standard mode only.

Figure 24. Asynchronous Write and $\overline{\text{PAE}}$ Flag - IDT Standard Mode

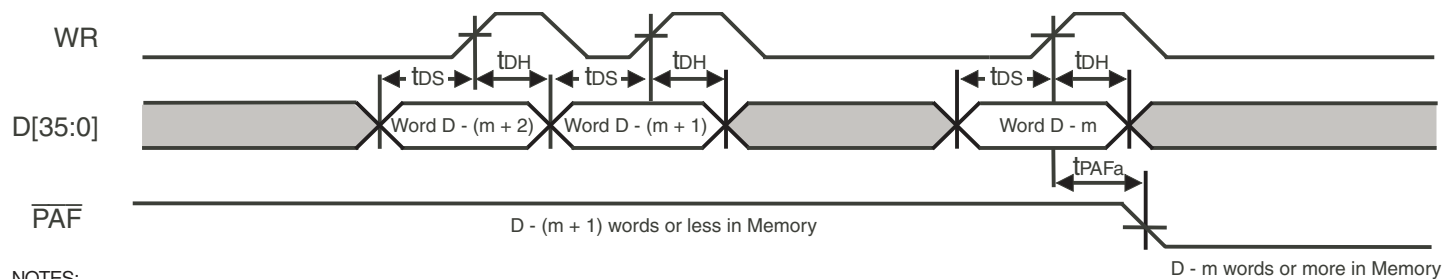

6357 drw39

NOTES:

1. $m = \overline{\text{PAF}}$ offset, see Table10 for information on $\overline{\text{PAF}}$ offset values. D = density of SFC.
2. Settings: $\overline{\text{WCS}} = \text{LOW}$, $\text{BM}[3:0] = 1000$, $\text{FWFT} = \text{LOW}$, $\overline{\text{ASYR}} = \text{LOW}$, and $\overline{\text{ASYW}} = \text{LOW}$.
3. Asynchronous read is available in IDT standard mode only.

Figure 25. Asynchronous Write and $\overline{\text{PAF}}$ Flag - IDT Standard Mode

Symbol	Parameter	6ns		7-5ns		Unit
		Min.	Max.	Min.	Max.	
t _{DS}	Data Setup Time	2	—	2.5	—	ns
t _{DH}	Data Hold Time	0.5	—	0.5	—	ns
t _{Aa}	Data Access Time	0.6	8	0.6	10	ns
t _{PAFa}	Rising Edge to $\overline{\text{PAF}}$	—	8	—	10	ns

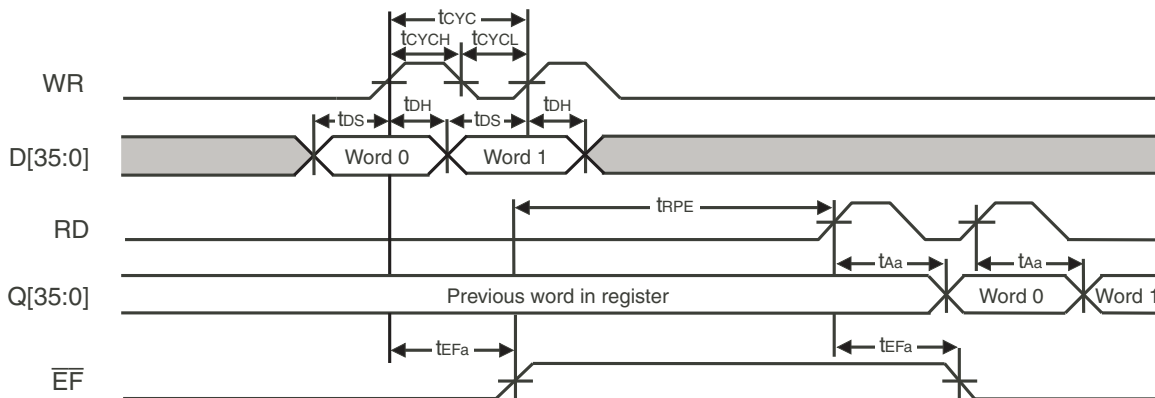

NOTES:

- Settings: $\overline{OE} = \text{LOW}$, $\overline{RCS} = \text{LOW}$, $\overline{WCS} = \text{LOW}$, $\overline{FWFT} = \text{LOW}$, $\overline{ASYR} = \text{LOW}$, and $\overline{ASYW} = \text{LOW}$.
- Asynchronous read is available in IDT standard mode only.

6357 drw40

Figure 26. Asynchronous Empty Boundary - IDT Standard Mode

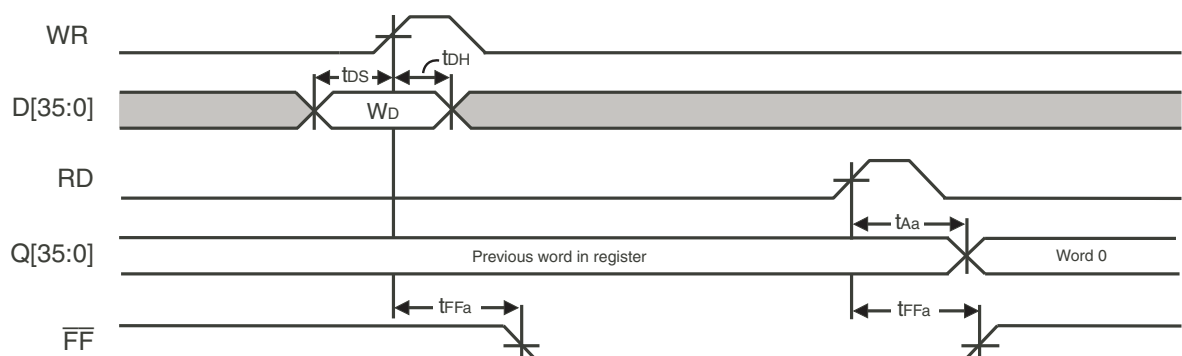

NOTES:

- Settings: $\overline{OE} = \text{LOW}$, $\overline{RCS} = \text{LOW}$, $\overline{WCS} = \text{LOW}$, $\overline{FWFT} = \text{LOW}$, $\overline{ASYR} = \text{LOW}$, and $\overline{ASYW} = \text{LOW}$.
- Asynchronous read is available in IDT standard mode only.

6357 drw41

Figure 27. Asynchronous Full Boundary - IDT Standard Mode

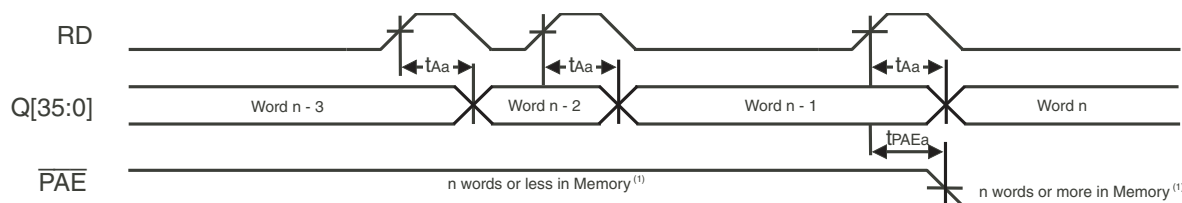

NOTES:

- $n = \overline{PAE}$ offset, see Table10 for information on \overline{PAE} offset values.
- Asynchronous read is available in IDT standard mode only.

6357 drw42

Figure 28. Asynchronous Read and \overline{PAE} Flag - IDT Standard Mode

Symbol	Parameter	6ns		7-5ns		Unit
		Min.	Max.	Min.	Max.	
tAa	Data Access Time	0.6	8	0.6	10	ns
tCyc	Cycle Time	10	—	12	—	ns
tCYCH	Cycle HIGH Time	4.5	—	5	—	ns
tCYCL	Cycle LOW Time	4.5	—	5	—	ns
tDH	Data Hold Time	0.5	—	0.5	—	ns
tDS	Data Setup Time	2	—	2.5	—	ns
tEFa	Rising Edge to \overline{EF}	—	8	—	10	ns
tFFa	Rising Edge to \overline{FF}	—	8	—	10	ns
tPAEa	Rising Edge to \overline{PAE}	—	8	—	10	ns
tRPE	Read Pulse after \overline{EF} HIGH	8	—	10	—	ns

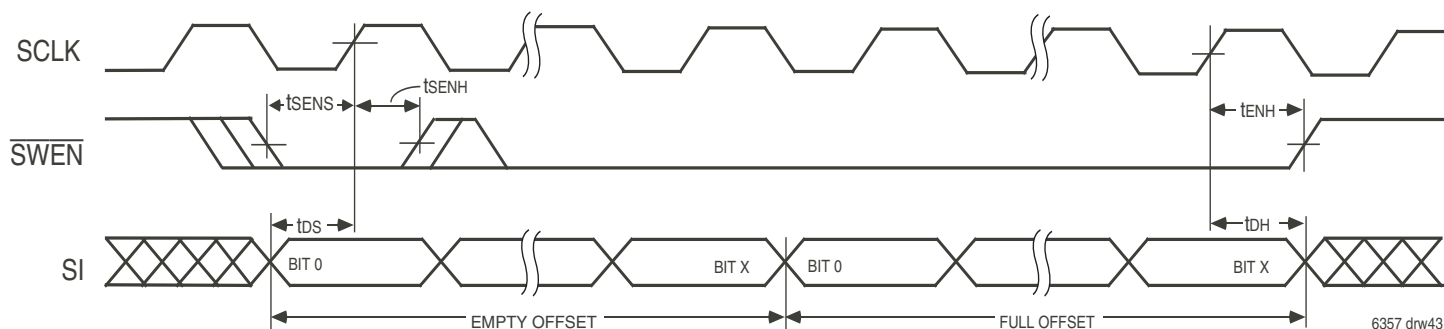

NOTES:

- Settings: JSEL = LOW.
- x is the required number of bits to program the $\overline{\text{PAE}}$ and $\overline{\text{PAF}}$ offset registers. See Table 12 for the numbers based on the values external configurations.

Figure 29. Serial Loading of Programmable Flag Registers (IDT Standard and FWFT Modes)

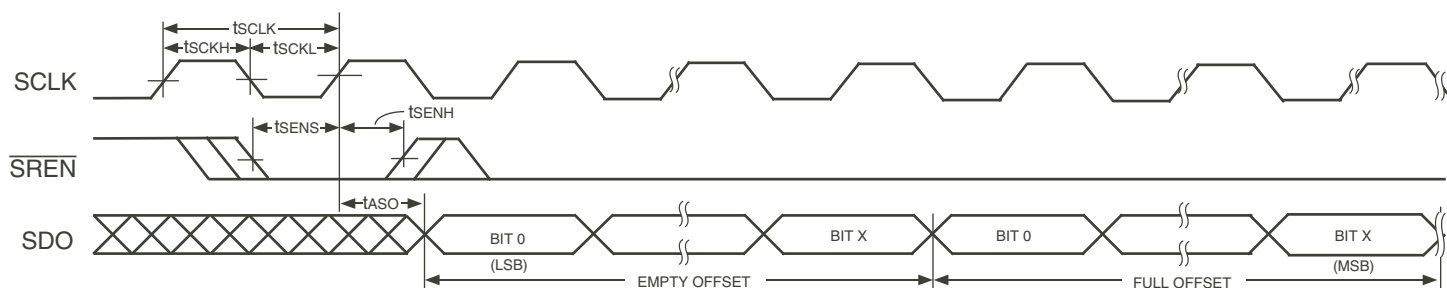

NOTES:

- Settings: JSEL = LOW.
- x is the required number of bits to program the $\overline{\text{PAE}}$ and $\overline{\text{PAF}}$ offset registers. See Table 12 for the numbers based on the values external configurations.

Figure 30. Reading of Programmable Flag Registers (IDT Standard and FWFT Modes)

Symbol	Parameter	6ns		7-5ns		Unit
		Min.	Max.	Min.	Max.	
t _{DH}	Data Hold Time	0.5	—	0.5	—	ns
t _{DS}	Data Setup Time	2	—	2.5	—	ns
t _{ASO}	Serial Output Data Access Time	—	20	—	20	ns
t _{SENS}	Serial Enable Setup	5	—	5	—	ns
t _{SENH}	Serial Enable Hold	5	—	5	—	ns
t _{SCLK}	Serial Clock Cycle	10	—	10	—	ns
t _{SCLKH}	Serial Clock HIGH	45	—	45	—	ns
t _{SCLKL}	Serial Clock LOW	45	—	45	—	ns

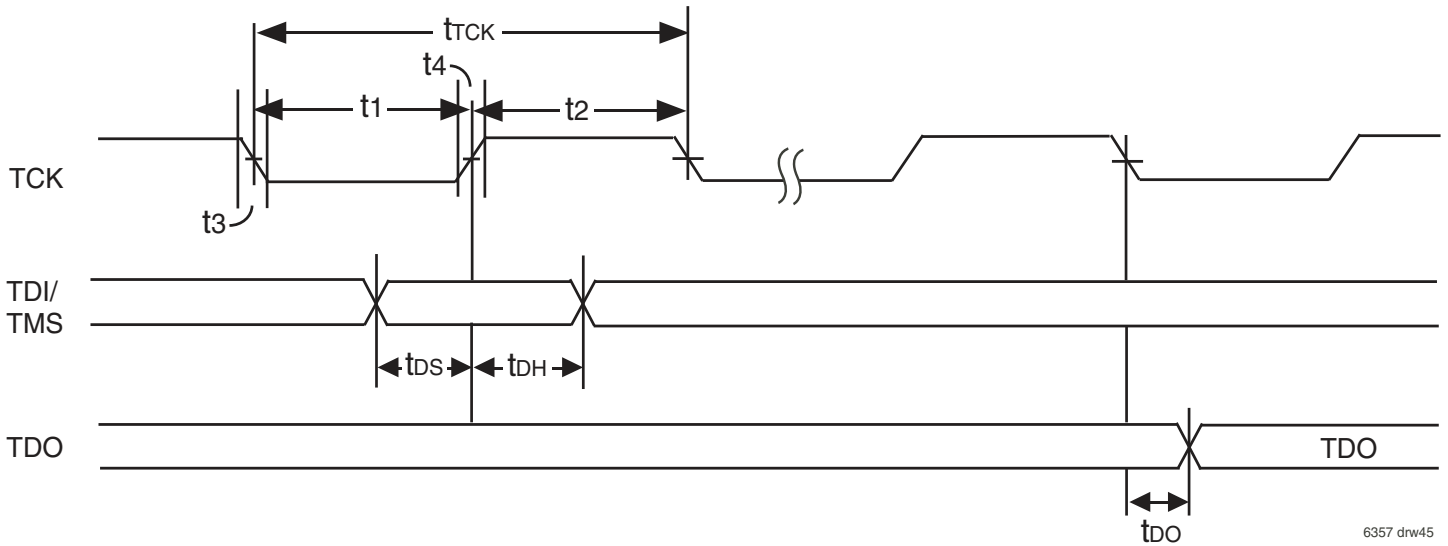

Notes to diagram:
 t1 = tTCKLOW
 t2 = tTCKHIGH
 t3 = tTCKFALL
 t4 = tTCKRISE

Figure 31. Standard JTAG Timing

SYSTEM INTERFACE PARAMETERS

Parameter	Symbol	Test Conditions	IDT72T6360		
			Min.	Max.	Units
Data Output	tDO ⁽¹⁾		-	20	ns
Data Output Hold	tDOH ⁽¹⁾		0	-	ns
Data Input	tDS	trise=3ns	10	-	ns
	tDH	tfall=3ns	10	-	ns

NOTE:
 1. 50pf loading on external output signals.

JTAG
 AC ELECTRICAL CHARACTERISTICS

(VCC = 2.5V ± 5%; Tambient (Industrial) = 0°C to +85°C)

Parameter	Symbol	Test Conditions	Min.	Max.	Units
			JTAG Clock Input Period	tTCK	-
JTAG Clock HIGH	tTCKHIGH	-	40	-	ns
JTAG Clock Low	tTCKLOW	-	40	-	ns
JTAG Clock Rise Time	tTCKRISE	-	-	5 ⁽¹⁾	ns
JTAG Clock Fall Time	tTCKFALL	-	-	5 ⁽¹⁾	ns

NOTE:
 1. Guaranteed by design.

JTAG TIMING SPECIFICATIONS (IEEE 1149.1 COMPLIANT)

The JTAG test port in this device is fully compliant with the IEEE Standard Test Access Port (IEEE 1149.1) specifications. Four additional pins (TDI, TDO, TMS and TCK) are provided to support the JTAG boundary scan interface. Note that IDT provides appropriate Boundary Scan Description Language program files for these devices.

The Standard JTAG interface consists of seven basic elements:

- Test Access Port (TAP)
- TAP controller
- Instruction Register (IR)
- Data Register Port (DR)
- Bypass Register (BYR)
- ID Code Register

The following sections provide a brief description of each element. For a complete description refer to the IEEE Standard Test Access Port Specification (IEEE Std. 1149.1-1990).

The Figure below shows the standard Boundary-Scan Architecture

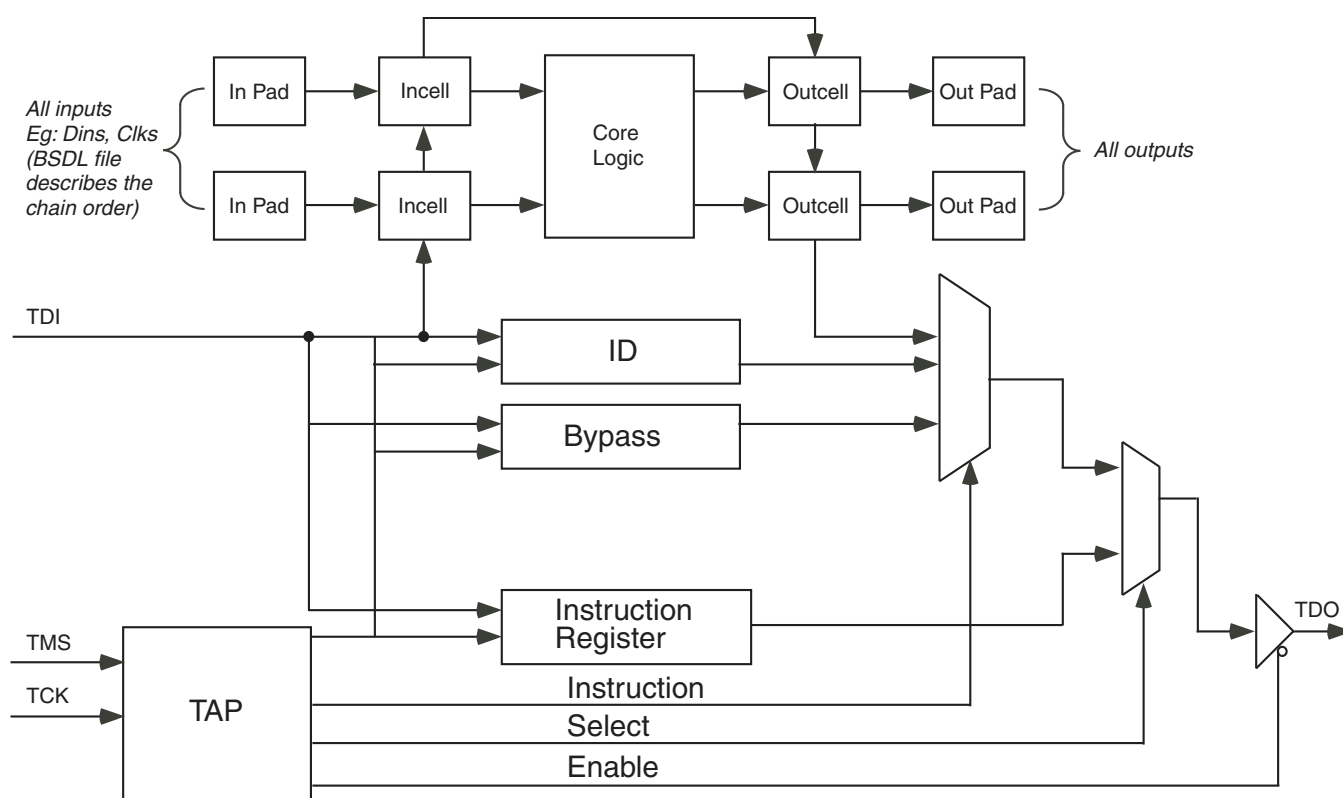

6357 drw46

Figure 32. JTAG Architecture

TEST ACCESS PORT (TAP)

The TAP interface is a general-purpose port that provides access to the internal JTAG state machine. It consists of three input ports (TCLK, TMS, TDI) and one output port (TDO).

THE TAP CONTROLLER

The TAP controller is a synchronous finite state machine that responds to TMS and TCLK signals to generate clock and control signals to the Instruction and Data Registers for capture and updating of data passed through the TDI serial input.

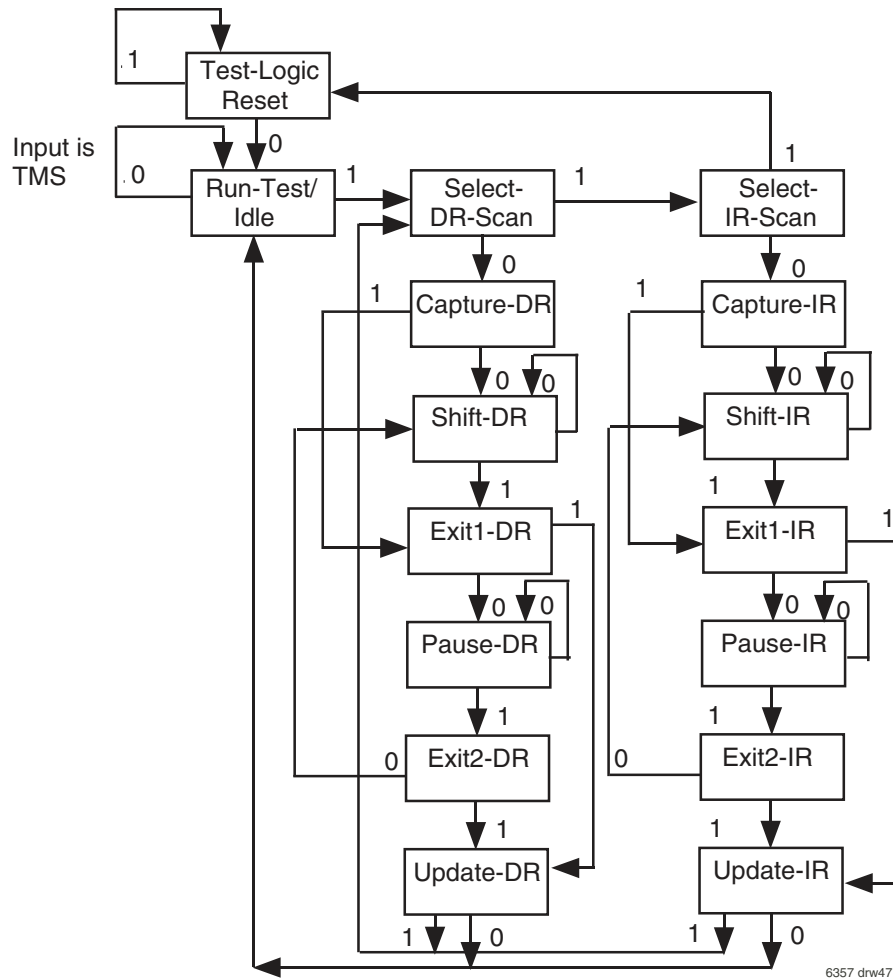

NOTES:

1. Five consecutive 1's at TMS will reset the TAP.
2. TAP controller resets automatically upon power-up.

Figure 33. TAP Controller State Diagram

Refer to the IEEE Standard Test Access Port Specification (IEEE Std. 1149.1) for the full state diagram

All state transitions within the TAP controller occur at the rising edge of the TCLK pulse. The TMS signal level (0 or 1) determines the state progression that occurs on each TCLK rising edge.

Test-Logic-Reset All test logic is disabled in this controller state enabling the normal operation of the IC. The TAP controller state machine is designed in such a way that, no matter what the initial state of the controller is, the Test-Logic-Reset state can be entered by holding TMS at high and pulsing TCK five times.

Run-Test-Idle In this controller state, the test logic in the IC is active only if certain instructions are present. For example, if an instruction activates the self test, then it will be executed when the controller enters this state. The test logic in the IC is idle otherwise.

Select-DR-Scan This is a controller state where the decision to enter the Data Path or the Select-IR-Scan state is made.

Select-IR-Scan This is a controller state where the decision to enter the Instruction Path is made. The Controller can return to the Test-Logic-Reset state otherwise.

Capture-IR In this controller state, the shift register bank in the Instruction Register parallel loads a pattern of fixed values on the rising edge of TCK. The last two significant bits are always required to be "01".

Shift-IR In this controller state, the instruction register gets connected between TDI and TDO, and the captured pattern gets shifted on each rising edge of TCK. The instruction available on the TDI pin is also shifted in to the instruction register. TDO changes on the falling edge of TCK.

Exit1-IR This is a controller state where a decision to enter either the Pause-IR state or Update-IR state is made.

Pause-IR This state is provided in order to allow the shifting of instruction register to be temporarily halted.

Exit2-DR This is a controller state where a decision to enter either the Shift-IR state or Update-IR state is made.

Update-IR In this controller state, the instruction in the instruction register scan chain is latched in to the register of the Instruction Register on every falling edge of TCK. This instruction also becomes the current instruction once it is latched.

Capture-DR In this controller state, the data is parallel loaded in to the data registers selected by the current instruction on the rising edge of TCK.

Shift-DR, Exit1-DR, Pause-DR, Exit2-DR and Update-DR These controller states are similar to the Shift-IR, Exit1-IR, Pause-IR, Exit2-IR and Update-IR states in the Instruction path.

THE INSTRUCTION REGISTER

The instruction register (IR) is eight bits long and tells the device what instruction is to be executed. Information contained in the instruction includes the mode of operation (either normal mode, in which the device performs its normal logic function, or test mode, in which the normal logic function is inhibited or altered), the test operation to be performed, which of the four data registers is to be selected for inclusion in the scan path during data-register scans, and the source of data to be captured into the selected data register during Capture-DR.

TEST DATA REGISTER

The Test Data register contains three test data registers: the Bypass, the Boundary Scan register and Device ID register.

These registers are connected in parallel between a common serial input and a common serial data output.

The following sections provide a brief description of each element. For a complete description, refer to the IEEE Standard Test Access Port Specification (IEEE Std. 1149.1-1990).

TEST BYPASS REGISTER

The register is used to allow test data to flow through the device from TDI to TDO. It contains a single stage shift register for a minimum length in the serial path. When the bypass register is selected by an instruction, the shift register stage is set to a logic zero on the rising edge of TCLK when the TAP controller is in the Capture-DR state.

The operation of the bypass register should not have any effect on the operation of the device in response to the BYPASS instruction.

THE BOUNDARY-SCAN REGISTER

The boundary-scan register (BSR) contains one boundary-scan cell (BSC) for each normal-function input pin and one BSC for each normal-function I/O pin (one single cell for both input data and output data). The BSR is used 1) to store test data that is to be applied externally to the device output pins, and/or 2) to capture data that appears internally at the outputs of the normal on-chip logic and/or externally at the device input pins.

THE DEVICE IDENTIFICATION REGISTER

The Device Identification Register is a Read Only 32-bit register used to specify the manufacturer, part number and version of the device to be determined through the TAP in response to the IDCODE instruction.

IDT JEDEC ID number is 0xB3. This translates to 0x33 when the parity is dropped in the 11-bit Manufacturer ID field.

For the IDT72T6360, the Part Number field contains the following values:

Device	Part# Field
IDT72T6360	0437 (hex)

31(MSB)	28 27	12 11	1 0(LSB)
Version (4 bits)	Part Number (16-bit)	Manufacturer ID (11-bit)	1
0000		0033 (hex)	1

IDT72T6360 JTAG Device Identification Register

JTAG INSTRUCTION REGISTER

The Instruction register allows an instruction to be serially input into the device when the TAP controller is in the Shift-IR state. The instruction is decoded to perform the following:

- Select test data registers that may operate while the instruction is current. The other test data registers should not interfere with chip operation and the selected data register.
- Define the serial test data register path that is used to shift data between TDI and TDO during data register scanning.

The Instruction Register is a 4 bit field (i.e. IR3, IR2, IR1, IR0) to decode 16 different possible instructions. Instructions are decoded as follows.

Hex Value	Instruction	Function
0000	EXTEST	Test external pins
0001	SAMPLE/PRELOAD	Select boundary scan register
0002	IDCODE	Selects chip identification register
0003	HIGH-IMPEDANCE	Puts all outputs in high-impedance state
0008	CLAMP	Fix the output chains to scan chain values
000F	BYPASS	Select bypass register
	Private	Several combinations are private (for IDT internal use). Do not use codes other than those identified above.

JTAG INSTRUCTION REGISTER DECODING

The following sections provide a brief description of each instruction. For a complete description refer to the IEEE Standard Test Access Port Specification (IEEE Std. 1149.1-1990).

EXTEST

The required EXTEST instruction places the device into an external boundary-test mode and selects the boundary-scan register to be connected between TDI and TDO. During this instruction, the boundary-scan register is accessed to drive test data off-chip via the boundary outputs and receive test data off-chip via the boundary inputs. As such, the EXTEST instruction is the workhorse of IEEE Std 1149.1, providing for probe-less testing of solder-joint opens/shorts and of logic cluster function.

SAMPLE/PRELOAD

The required SAMPLE/PRELOAD instruction allows the device to remain in a normal functional mode and selects the boundary-scan register to be connected between TDI and TDO. During this instruction, the boundary-scan register can be accessed via a data scan operation, to take a sample of the functional data entering and leaving the device. This instruction is also used to preload test data into the boundary-scan register before loading an EXTEST instruction.

IDCODE

The optional IDCODE instruction allows the device to remain in its functional mode and selects the optional device identification register to be connected between TDI and TDO. The device identification register is a 32-bit shift register containing information regarding the device manufacturer, device type, and version code. Accessing the device identification register does not interfere with the operation of the device. Also, access to the device identification register should be immediately available, via a TAP data-scan operation, after power-up of the device or by otherwise moving to the Test-Logic-Reset state.

CLAMP

The optional CLAMP instruction sets the outputs of an device to logic levels determined by the contents of the boundary-scan register and selects the one-bit bypass register to be connected between TDI and TDO. Before loading this instruction, the contents of the boundary-scan register can be preset with the SAMPLE/PRELOAD instruction. During this instruction, data can be shifted through the bypass register from TDI to TDO without affecting the condition of the outputs.

HIGH-IMPEDANCE

The optional High-Impedance instruction sets all outputs (including two-state as well as three-state types) of an device to a disabled (high-impedance) state

and selects the one-bit bypass register to be connected between TDI and TDO. During this instruction, data can be shifted through the bypass register from TDI to TDO without affecting the condition of the device outputs.

BYPASS

The required BYPASS instruction allows the device to remain in a normal functional mode and selects the one-bit bypass register to be connected between TDI and TDO. The BYPASS instruction allows serial data to be transferred through the IC from TDI to TDO without affecting the operation of the device.

DEPTH EXPANSION CONFIGURATION

The sequential flow-control (SFC) device can be connected with multiple SFCs in depth expansion to provide additional storage density that's greater than 1Gb. In depth expansion mode, two or more devices are connected through a common transfer interface, as shown in Figure 34. The transfer clock can be a separate free-running clock or driven from the same system write or read clock.

In depth expansion configuration, the first word written to an empty configuration will pass from the first SFC to the next until it appears on the second (or last) SFC in the chain. If no reads are performed, data will begin accumulating in the second SFC until it is full. Once the second SFC is full it will disable the REN to the first SFC. At this point data will begin accumulating in the first SFC. Once both devices are full, the entire configuration is full and the full flag indicator will go LOW.

For an empty configuration, the amount of time it takes for the empty flag of the second (or last) SFC in the chain to go LOW (i.e. valid data available to be

read out of the device) after a word has been written into the first FIFO is the sum of the delays for each individual SFC:

$$(N - 1) \times (4 \times \text{transfer clock}) + 3 \times \text{RCLK}$$

Where N is the number of SFCs in the chain and RCLK is the RCLK period in ns. This latency is only noticeable for the first word written to an empty configuration. There will be no delay evident for subsequent words written into the chain.

In the full configuration, the amount of time it takes for the FF of the first SFC to go from LOW to HIGH after reading one word from the chain is the sum of the delays for each individual SFC:

$$(N - 1) \times (3 \times \text{transfer clock}) + 2 \times \text{WCLK}$$

Depth expansion is available in both IDT Standard mode and First Word Fall Through (FWFT) mode. If IDT Standard mode is selected, the IDEM signal needs to be HIGH. If FWFT mode is selected, the IDEM signal needs to be LOW.

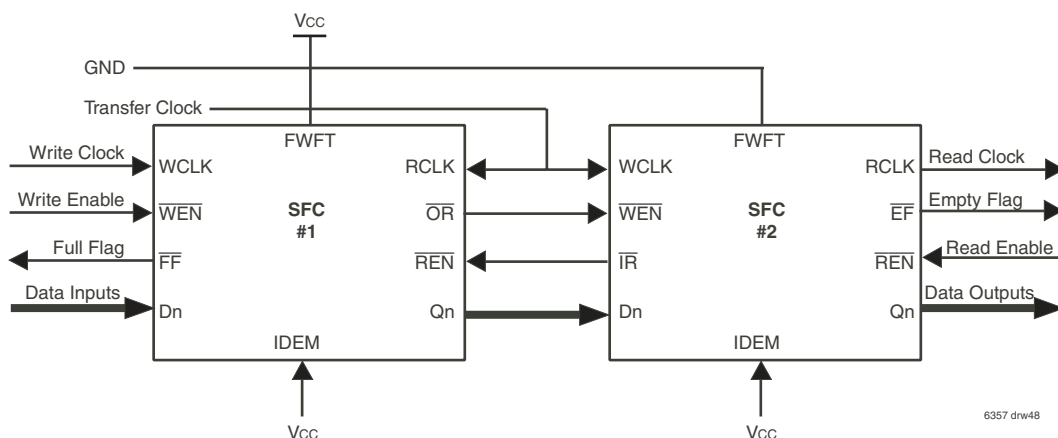

Figure 34. Depth Expansion Configuration in IDT Standard Mode

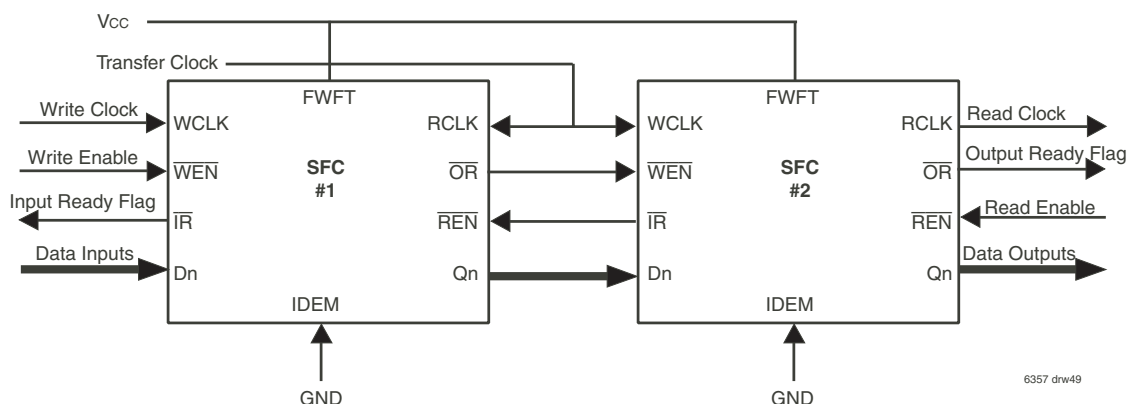
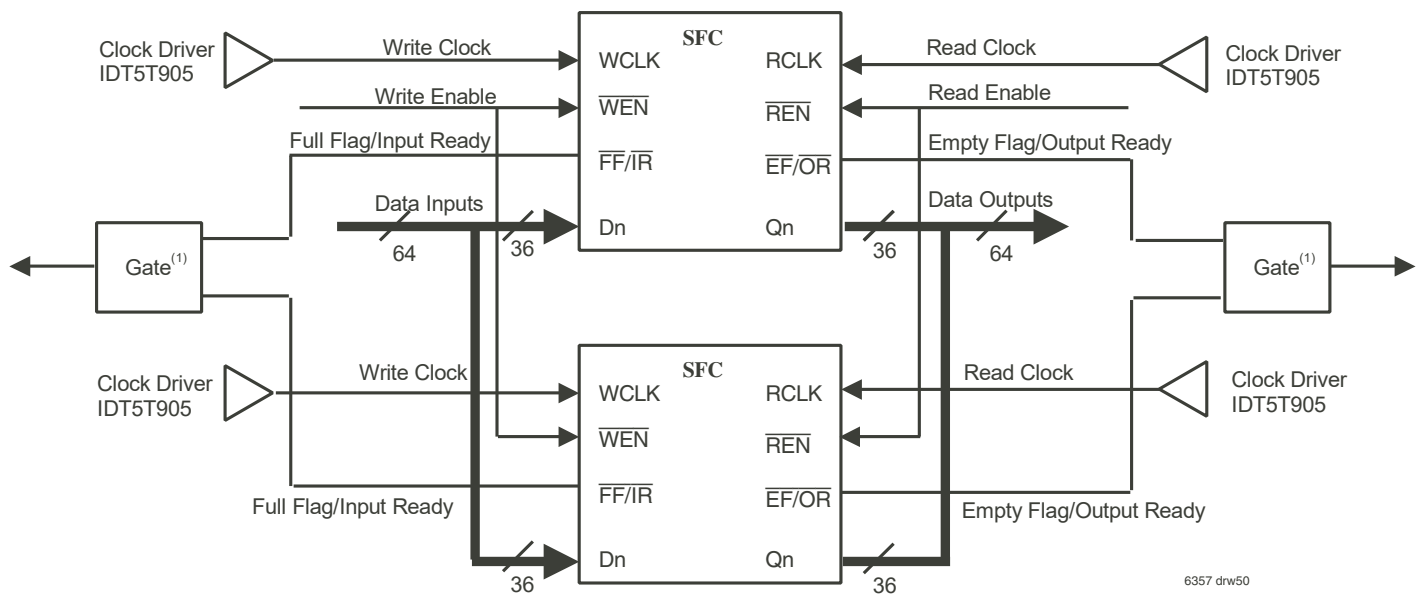

Figure 35. Depth Expansion Configuration in FWFT Mode

WIDTH EXPANSION CONFIGURATION

The sequential flow-control (SFC) device can be connected with another SFCs in width expansion to support bus-widths greater than 36-bits. This configuration connects the input and output bus of two devices together to create a wider bus. The read and write clocks for each device are driven with a clock driver (IDT5T905 recommended) is used to drive the input clocks for both SFC devices. Figure 36 illustrates the width expansion configuration.

clock, it is possible for $\overline{EF}/\overline{OR}$ deassertion and $\overline{IR}/\overline{OR}$ assertion to vary from one cycle between the devices. The logic gate connected to the status flags will create a composite flag that will update the status of both SFC devices to represent a more accurate status of the configuration. To minimize the skew between the two write and read clocks, a clock driver (IDT5T905 recommended) is used to drive the input clocks for both SFC devices. Figure 36 illustrates the width expansion configuration.



NOTES:

1. Use an AND gate in IDT Standard mode, an OR gate in FWFT mode.
2. Do not connect any output signals directly together.

Figure 36. Width Expansion Configuration in IDT Standard Mode and FWFT Mode

ORDERING INFORMATION

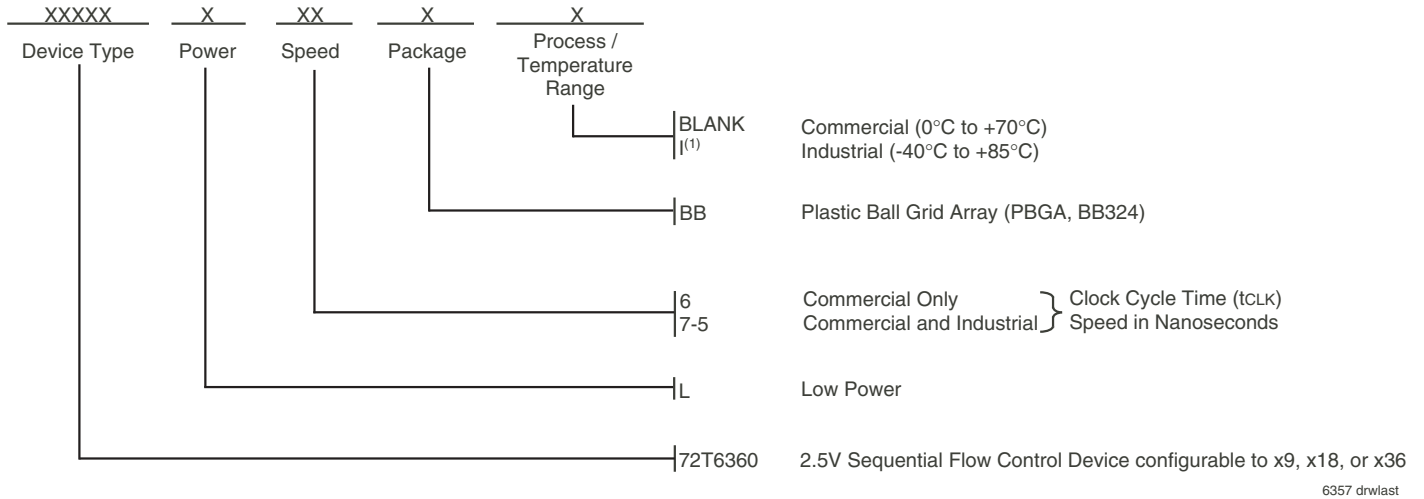

DATASHEET DOCUMENT HISTORY

07/29/2004	pgs. 1, 4, 7-11, 13-25, 27-43, 47, 49, and 51.
04/11/2005	pgs. 6 and 10.
06/28/2005	pg. 16.
10/10/2005	pgs. 1, 15, and 16.
02/10/2009	pg. 51.
04/26/2009	PDN# F-09-01 issued. See IDT.com for PDN specifics.
09/04/2019	Datasheet changed to Obsolete Status.

IMPORTANT NOTICE AND DISCLAIMER

RENESAS ELECTRONICS CORPORATION AND ITS SUBSIDIARIES (“RENESAS”) PROVIDES TECHNICAL SPECIFICATIONS AND RELIABILITY DATA (INCLUDING DATASHEETS), DESIGN RESOURCES (INCLUDING REFERENCE DESIGNS), APPLICATION OR OTHER DESIGN ADVICE, WEB TOOLS, SAFETY INFORMATION, AND OTHER RESOURCES “AS IS” AND WITH ALL FAULTS, AND DISCLAIMS ALL WARRANTIES, EXPRESS OR IMPLIED, INCLUDING, WITHOUT LIMITATION, ANY IMPLIED WARRANTIES OF MERCHANTABILITY, FITNESS FOR A PARTICULAR PURPOSE, OR NON-INFRINGEMENT OF THIRD PARTY INTELLECTUAL PROPERTY RIGHTS.

These resources are intended for developers skilled in the art designing with Renesas products. You are solely responsible for (1) selecting the appropriate products for your application, (2) designing, validating, and testing your application, and (3) ensuring your application meets applicable standards, and any other safety, security, or other requirements. These resources are subject to change without notice. Renesas grants you permission to use these resources only for development of an application that uses Renesas products. Other reproduction or use of these resources is strictly prohibited. No license is granted to any other Renesas intellectual property or to any third party intellectual property. Renesas disclaims responsibility for, and you will fully indemnify Renesas and its representatives against, any claims, damages, costs, losses, or liabilities arising out of your use of these resources. Renesas' products are provided only subject to Renesas' Terms and Conditions of Sale or other applicable terms agreed to in writing. No use of any Renesas resources expands or otherwise alters any applicable warranties or warranty disclaimers for these products.

(Disclaimer Rev.1.0 Mar 2020)

Corporate Headquarters

TOYOSU FORESIA, 3-2-24 Toyosu,
Koto-ku, Tokyo 135-0061, Japan
www.renesas.com

Contact Information

For further information on a product, technology, the most up-to-date version of a document, or your nearest sales office, please visit:
www.renesas.com/contact/

Trademarks

Renesas and the Renesas logo are trademarks of Renesas Electronics Corporation. All trademarks and registered trademarks are the property of their respective owners.