



STEVAL-ISV001V1

1000 W dual stage DC-AC converter demonstration board
based on the STP160N75F3

Data Brief

Features

- Nominal input voltage: 24 V
- Output voltage: 230 Vrms, 50 Hz
- Output power: 1 kW
- Efficiency: 90%
- Switching frequency: 100 kHz (DC-DC); 16 kHz (DC-AC)

Description

The STEVAL-ISV001V1 demonstration board implements a 1 kW dual stage DC-AC converter, suitable for use in battery powered uninterruptible power supplies (UPS) or photovoltaic (PV) stand alone systems. The converter is powered from a low DC input voltage varying from 20 V to 28 V and is capable of supplying up to 1 kW output power on a single phase AC load. These features are met with a dual stage conversion topology including an efficient step-up push-pull DC-DC converter, to produce a regulated high voltage DC bus, and a sinusoidal h-bridge PWM inverter to generate a 50 Hz, 230 Vrms output sine wave. Other relevant features of the proposed system are high power density, high switching frequency, galvanic isolation and efficiency greater than 90% over a wide output load range.



1 Circuit schematics

Figure 1. Converter schematic: the power stage

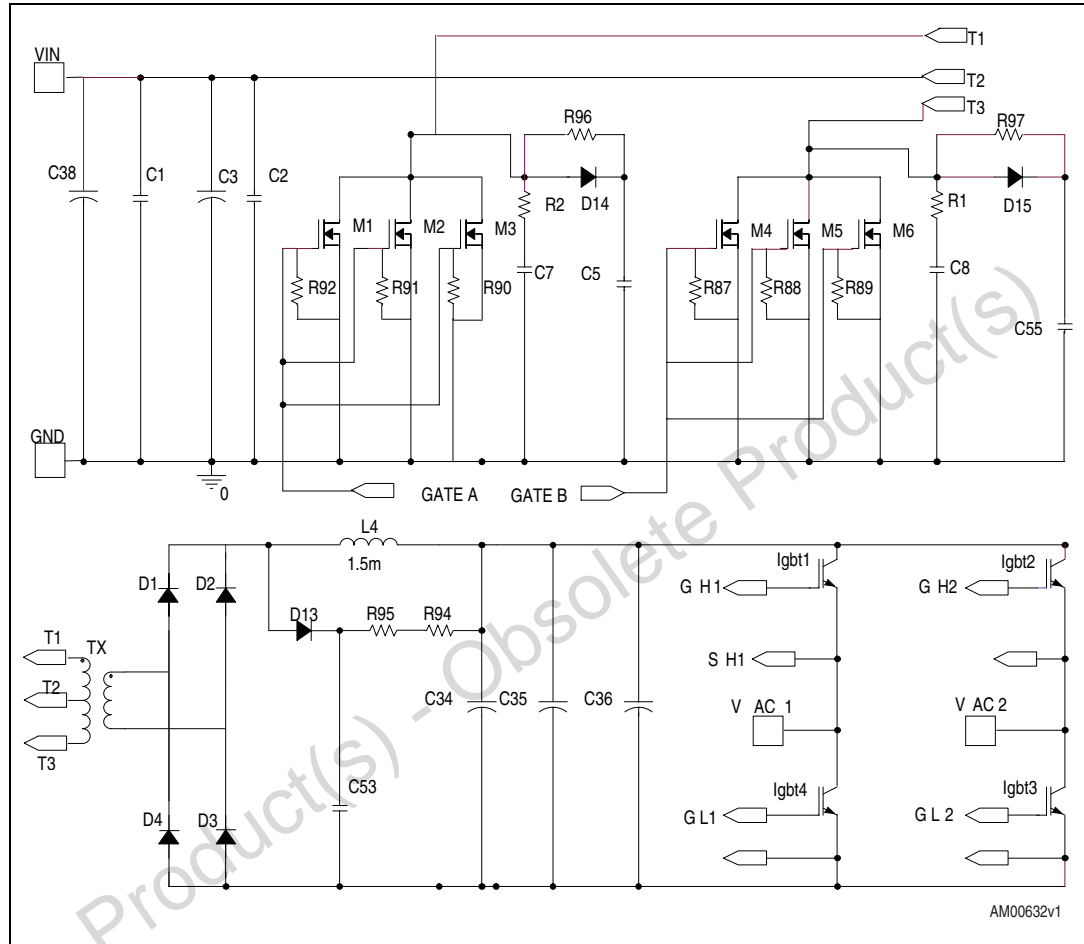
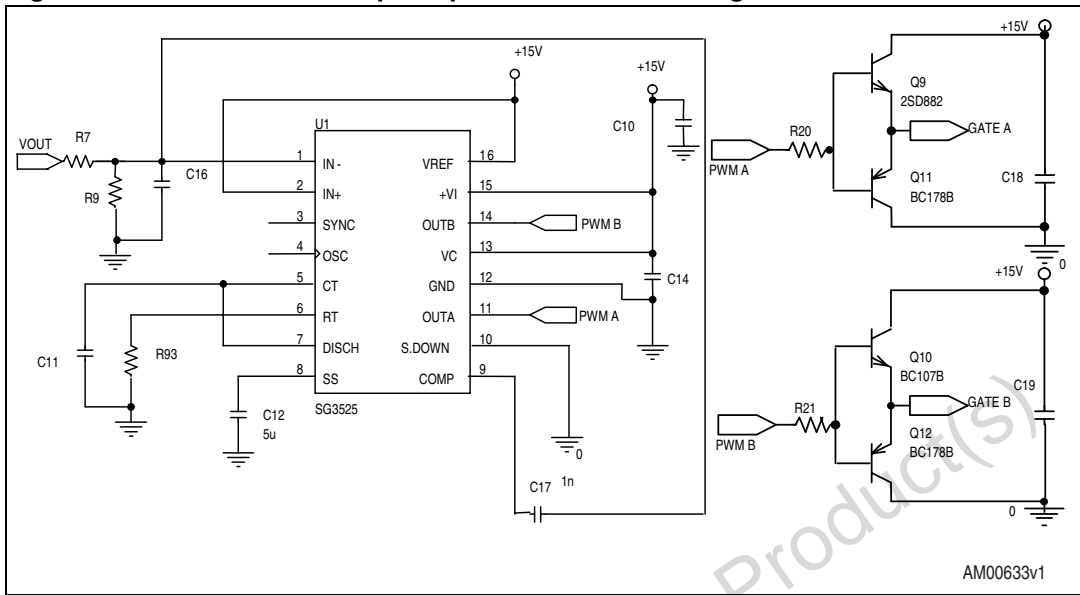
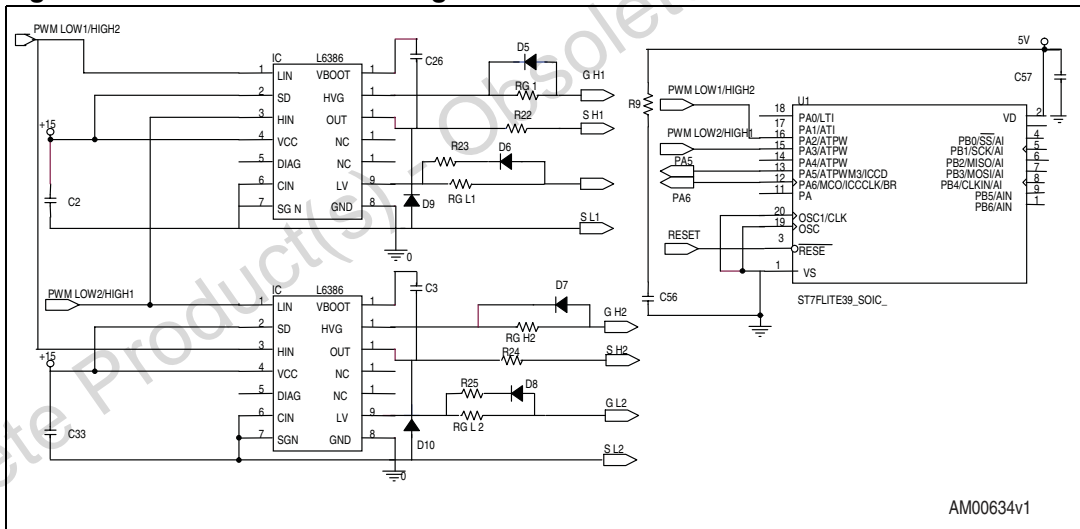

Figure 2. Schematic of the push-pull control and driving circuit



AM00633v1

Figure 3. Inverter control driving circuit schematic



AM00634v1

Figure 4. Schematic of the auxiliary power supply section

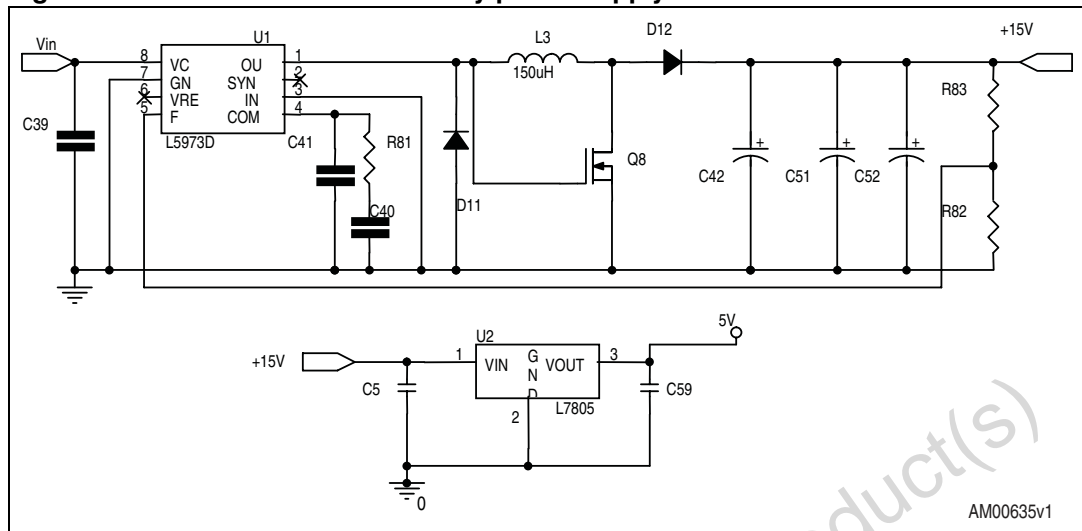

Obsolete Product(s) - Obsolete Product(s)

2 Revision history

Table 1. Document revision history

Date	Revision	Changes
27-Nov-2008	1	Initial release.

Obsolete Product(s) - Obsolete Product(s)

Please Read Carefully:

Information in this document is provided solely in connection with ST products. STMicroelectronics NV and its subsidiaries ("ST") reserve the right to make changes, corrections, modifications or improvements, to this document, and the products and services described herein at any time, without notice.

All ST products are sold pursuant to ST's terms and conditions of sale.

Purchasers are solely responsible for the choice, selection and use of the ST products and services described herein, and ST assumes no liability whatsoever relating to the choice, selection or use of the ST products and services described herein.

No license, express or implied, by estoppel or otherwise, to any intellectual property rights is granted under this document. If any part of this document refers to any third party products or services it shall not be deemed a license grant by ST for the use of such third party products or services, or any intellectual property contained therein or considered as a warranty covering the use in any manner whatsoever of such third party products or services or any intellectual property contained therein.

UNLESS OTHERWISE SET FORTH IN ST'S TERMS AND CONDITIONS OF SALE ST DISCLAIMS ANY EXPRESS OR IMPLIED WARRANTY WITH RESPECT TO THE USE AND/OR SALE OF ST PRODUCTS INCLUDING WITHOUT LIMITATION IMPLIED WARRANTIES OF MERCHANTABILITY, FITNESS FOR A PARTICULAR PURPOSE (AND THEIR EQUIVALENTS UNDER THE LAWS OF ANY JURISDICTION), OR INFRINGEMENT OF ANY PATENT, COPYRIGHT OR OTHER INTELLECTUAL PROPERTY RIGHT.

UNLESS EXPRESSLY APPROVED IN WRITING BY AN AUTHORIZED ST REPRESENTATIVE, ST PRODUCTS ARE NOT RECOMMENDED, AUTHORIZED OR WARRANTED FOR USE IN MILITARY, AIR CRAFT, SPACE, LIFE SAVING, OR LIFE SUSTAINING APPLICATIONS, NOR IN PRODUCTS OR SYSTEMS WHERE FAILURE OR MALFUNCTION MAY RESULT IN PERSONAL INJURY, DEATH, OR SEVERE PROPERTY OR ENVIRONMENTAL DAMAGE. ST PRODUCTS WHICH ARE NOT SPECIFIED AS "AUTOMOTIVE GRADE" MAY ONLY BE USED IN AUTOMOTIVE APPLICATIONS AT USER'S OWN RISK.

Resale of ST products with provisions different from the statements and/or technical features set forth in this document shall immediately void any warranty granted by ST for the ST product or service described herein and shall not create or extend in any manner whatsoever, any liability of ST.

ST and the ST logo are trademarks or registered trademarks of ST in various countries.

Information in this document supersedes and replaces all information previously supplied.

The ST logo is a registered trademark of STMicroelectronics. All other names are the property of their respective owners.

© 2008 STMicroelectronics - All rights reserved

STMicroelectronics group of companies

Australia - Belgium - Brazil - Canada - China - Czech Republic - Finland - France - Germany - Hong Kong - India - Israel - Italy - Japan - Malaysia - Malta - Morocco - Singapore - Spain - Sweden - Switzerland - United Kingdom - United States of America

www.st.com