

REV.	DATE	ECR NO.	DESCRIPTION
NC	08/18/98	-	INITIAL RELEASE
A	09/06/06	-	REVISE FERRULE I.D./ UPDATE DRAWING FORMAT
B	12/08/08	-	REVISE NOTE 2 TO .118" HEX CRIMP

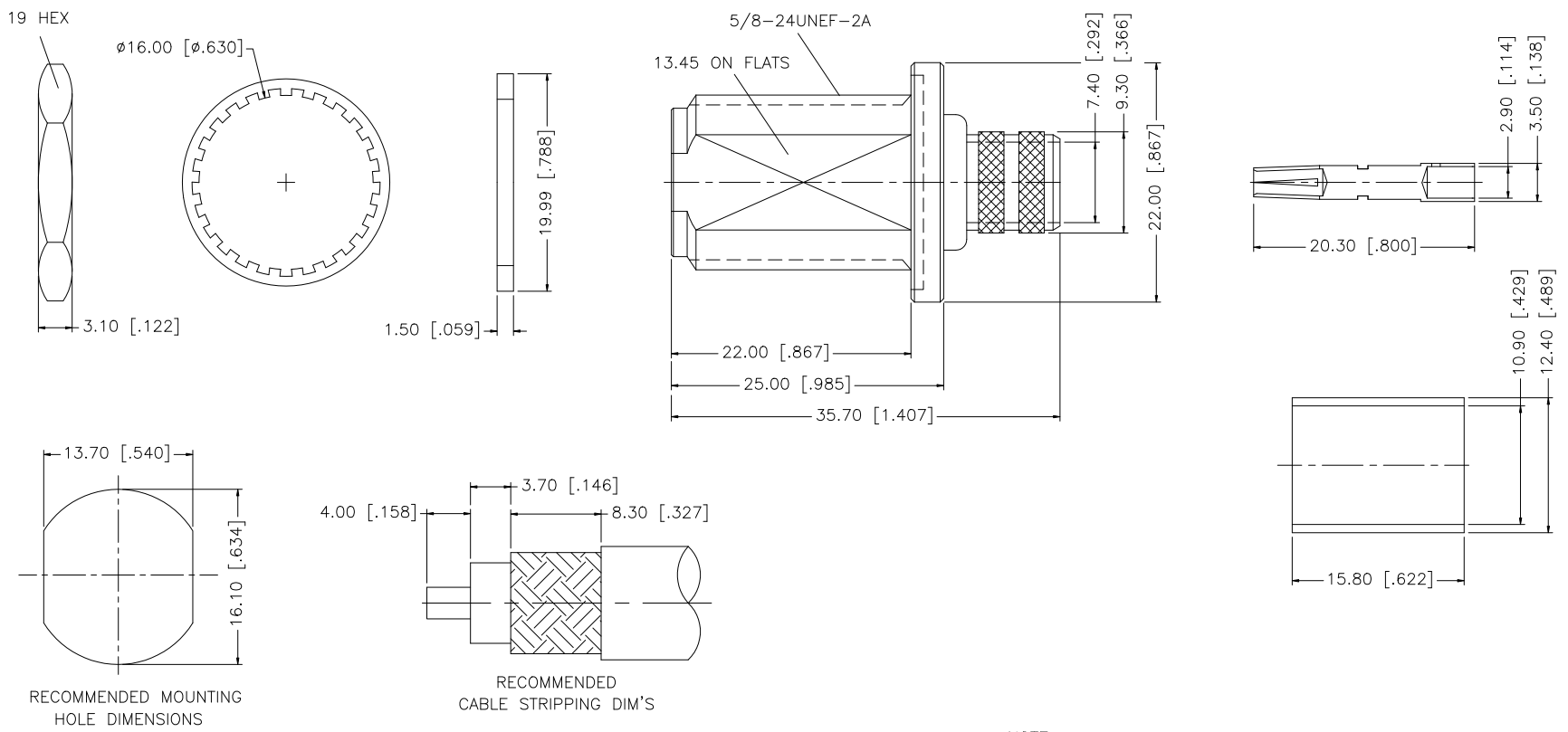

NOTE:
 1. CRIMPED FERRULE HEX CRIMP SIZE .429" [10.90]
 2. CRIMPED CONTACT PIN HEX CRIMP SIZE .118" [3.00]

DESCRIPTION	MATERIAL	FINISH	QTY
8			
7	FERRULE	COPPER	NICKEL 1
6	HEX NUT	BRASS	NICKEL 1
5	LOCK WASHER	BRASS	NICKEL 1
4	GASKET	SILICONE	RED 1
3	CONTACT PIN	PHOS. BRONZE	GOLD 1
2	INSULATOR	PTFE	NATURAL 1
1	BODY	BRASS	NICKEL 1

UNLESS OTHERWISE SPECIFIED DIMENSIONS ARE IN MILLIMETERS. DIMENSIONS IN [] ARE IN INCHES AND FOR CUSTOMER REFERENCE ONLY.

UNLESS OTHERWISE SPECIFIED TOLERANCES FOR MILLIMETERS ARE:
 0.5 - 8mm ± 0.20mm
 8 - 30mm ± 0.40mm
 30 - 120mm ± 0.50mm

UNLESS OTHERWISE SPECIFIED TOLERANCES FOR INCHES ARE:
 .020 - .315 = ± 0.007"
 .315 - 1.180 = ± 0.015"
 1.180 - 4.724 = ± 0.020"

DO NOT SCALE DRAWING

APPROVALS	DATE
DRAWN GRS	12/08/08
CHECKED	
ISSUED	
SHEET 1 OF 1	
CAD FILE	C:/172/172220.DWG

Amphenol Connex

PART DESCRIPTION
N BULKHEAD CRIMP JACK - LMR 400 (FOR BELDEN 8214, 9913, 9914)
PART NO. 172220
DWG. NO. 172220.DWG
REV. B
SIZE A
SCALE NA