

PART NO.	APPLICABLE NOTE(S)	A**	B	C	(D)	BOARD THICKNESS	DESCRIPTION
-1	1, 2, 3, 4, 6	.056 +.000/-.005 [1.422+.000/-.127]	.010+/-0.002 [.254+/-0.050]	.011+/-0.001 [.279+/-0.025]	.027 [.686]	.062	MACHINED
-2	1, 2, 3, 4, 5, 6	.056 +.000/-.005 [1.422+.000/-.127]	.010+/-0.002 [.254+/-0.050]	.011+/-0.001 [.279+/-0.025]	.027 [.686]	[1.57]	FINISH PLATED
-3	1, 2, 3, 4, 6	.102 +/-0.004 [2.591+/-1.00]	.056 +/-0.002[1.422+/-0.050]	.011+/-0.001 [.279+/-0.025]	.027 [.686]	.125	MACHINED
-4	1, 2, 3, 4, 5, 6	.102 +/-0.004 [2.591+/-1.00]	.056 +/-0.002[1.422+/-0.050]	.011+/-0.001 [.279+/-0.025]	.027 [.686]	[3.18]	FINISH PLATED
-5	1, 2, 3, 4, 6	.033+.000/-.003[.838+.000/-.076]	.005+/-0.002[.127+/-0.050]	.007+/-0.001[.178+/-0.025]	.013 [.330]	.0394	MACHINED
-6	1, 2, 3, 4, 5, 6	.033+.000/-.003[.838+.000/-.076]	.005+/-0.002[.127+/-0.050]	.007+/-0.001[.178+/-0.025]	.013 [.330]	[1.00]	FINISH PLATED
-7	1, 2, 3, 4, 6	.073+/-0.004[1.854+/-1.00]	.027+/-0.002[.686+/-0.050]	.011+/-0.001 [.279+/-0.025]	.027 [.686]	.093	MACHINED
-8	1, 2, 3, 4, 5, 6	.073+/-0.004[1.854+/-1.00]	.027+/-0.002[.686+/-0.050]	.011+/-0.001 [.279+/-0.025]	.027 [.686]	[2.36]	FINISH PLATED
-9	1, 2, 3, 4, 6	.125+/-0.004[3.175+/-1.00]	.079+/-0.002[2.007+/-0.050]	.011+/-0.001 [.279+/-0.025]	.027 [.686]	.150	MACHINED
-10	1, 2, 3, 4, 5, 6	.125+/-0.004[3.175+/-1.00]	.079+/-0.002[2.007+/-0.050]	.011+/-0.001 [.279+/-0.025]	.027 [.686]	[3.81]	FINISH PLATED
-11	1, 2, 3, 4, 6	.167+/-0.004[4.242+/-1.00]	.121+/-0.002[3.073+/-0.050]	.011+/-0.001 [.279+/-0.025]	.027 [.686]	.197	MACHINED
-12	1, 2, 3, 4, 5, 6	.167+/-0.004[4.242+/-1.00]	.121+/-0.002[3.073+/-0.050]	.011+/-0.001 [.279+/-0.025]	.027 [.686]	[5.00]	FINISH PLATED

REVISIONS			
REV.	DESCRIPTION	DATE	BY
A	ECO 32953 (CHG. MAT'L & FINISH)	10/05/17	HT
B	ECO 33862 (ADD KNURL SPEC.)	07/09/18	HT
C	ECO 35051 (ADD -3,-4)	7/31/2019	PV
D	ECO XXXXX (REVISE DIM)	8/6/2019	PV
E	ECO XXXXX (DIM'S CHANGE)	8/13/19	HT
E1	KNURL Ø.156+/-0.003 WAS Ø.165+/-0.003, Ø.132/.135 WAS Ø.145/.148	08/15/19	HT
E2	ADD KNURL DEPTH .008/.012 AND ADD REF. DIM. .140	08/26/19	HT
F	ECO 35152 (ADD .004 FLAT MAX, .009/.011 KNURL DEPTH WAS .008/.012 & REF DIM Ø.136 WAS .140, ADD -5 THRU -10)	09/13/19	HT
G	ECO 35488(ADD-11 &-12 FOR 5.00mm PCB THK)	02.13.20	HT

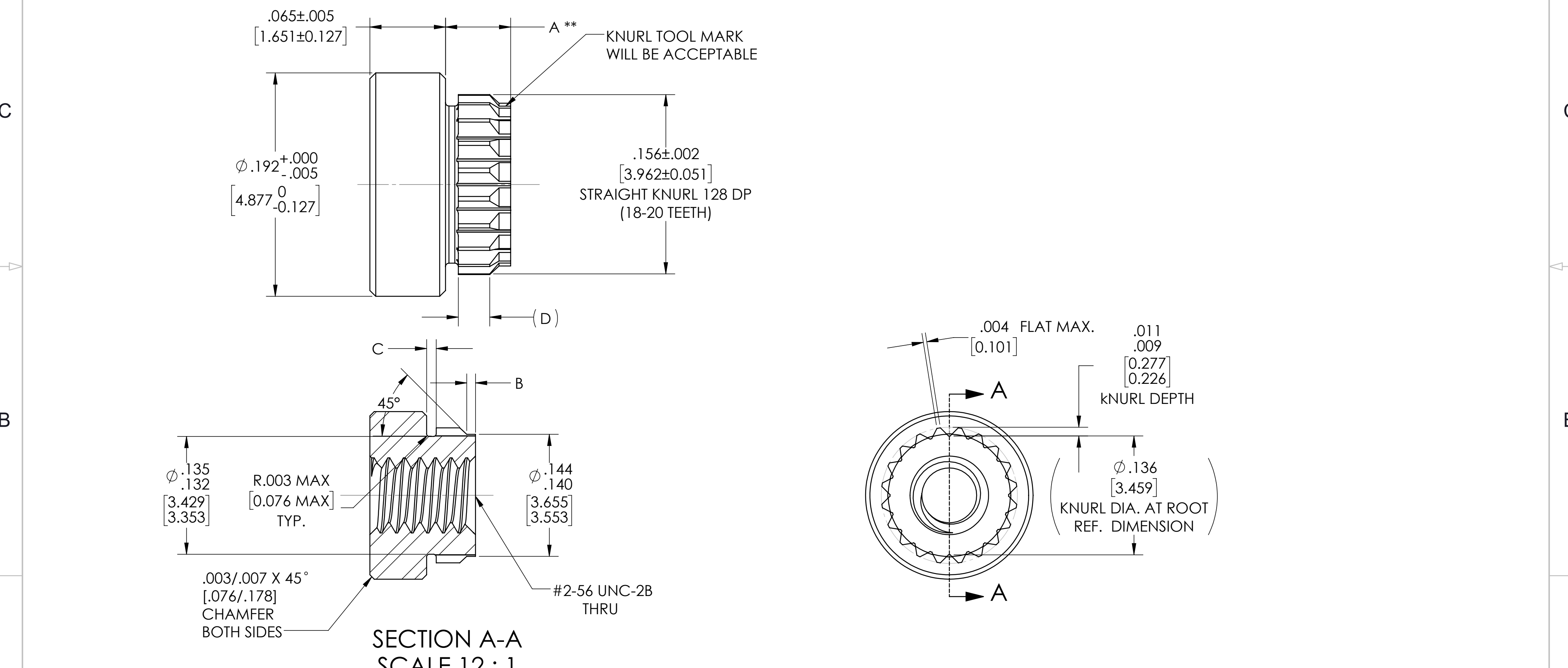

SECTION A-A  
SCALE 12 : 1

- NOTE(S):
1. MATERIAL: BRASS ALLOY, UNS No. C36000 PER ASTM B 16, TEMPER HO2.
  2. CRITICAL DIMENSIONS: \* \*.
  3. ALL MACHINED DIAMETERS TO BE CONCENTRIC WITH Ø .002 TIR.
  4. DIMENSIONS APPLY AFTER PLATING..
  5. BRIGHT NICKEL PLATE PER SAE AMS-QQ-N-290, CLASS 1, .000200/.000300 THICK, OVER COPPER STRIKE PER SAE AMS 2418.
  6. DIMENSIONS IN BRACKET ARE IN MILLIMETER.

APPLICABLE CARLISLE IT DOCUMENTS		
WORK STANDARD	PROD INSTRUC	ASSY INSTRUC
NA	NA	NA
-	-	-

**NOTICE**  
THIS DRAWING EMBODIES A CONFIDENTIAL PROPRIETARY DESIGN ORIGINATED BY CARLISLE INTERCONNECT TECHNOLOGIES & ALL DESIGN, MANUFACTURING, REPRODUCTION, USE & SALE RIGHTS REGARDING THE SAME ARE EXPRESSLY RESERVED. IT IS SUBMITTED UNDER A CONFIDENTIAL RELATIONSHIP FOR A SPECIFIED PURPOSE & THE RECIPIENT AGREES BY ACCEPTING THIS DRAWING NOT SUPPLY OR DISCLOSE ANY INFORMATION REGARDING IT TO ANY UNAUTHORIZED PERSON TO INCORPORATE IN OTHER PROJECTS ANY SPECIAL FEATURES PECULIAR TO THIS DESIGN. ALL PATENT RIGHTS HERETO ARE EXPRESSLY RESERVED BY CARLISLE INTERCONNECT TECHNOLOGIES, CERRITOS, CALIFORNIA 90703.

TOLERANCES AND NOTES EXCEPT AS NOTED	
DIMENSIONS ARE IN INCHES.	
LINEAR .XX ±.015	ANGULAR ± 1/2°
FRACTION ± 1/32	
1. MACHINE FINISH: 63 RMS	
2. BREAK ALL SHARP EDGES .003 MAX.	
3. MACHINED FILLETS .005 MAX.	
4. MACHINED SURFACES SQUARE TO RESPECTIVE AXIS WITHIN .005 INCHES PER INCH.	
5. MACHINED DIAMETERS CONCENTRIC WITHIN .002 T.I.R.	
6. DIMENSIONS TO BE MET BEFORE PLATING.	
7. CHAMFER ALL THREADS 45°.	
8. THREADS PER H-28	
9. REMOVE FRAVED EDGES ON TEFLON.	
10. REMOVE ALL BURRS.	

SEE NOTE(S)		SEE NOTE(S)	SEE NOTE(S)
MATERIAL		SPECIFICATION	PROCUREMENT
APPROVAL	INITIALS	DATE	
DRAWN BY	HT	08.14.17	
CHECKED BY	-	-	
TEST ENGR	-	-	
QUALITY	-	-	
DESIGN ENG	HT	09.06.17	
MFG. ENGR	-	-	
ECO APPRV	-	-	
TITLE		NUT, PRESS FIT	
SCALE	SUB-DIRECTORY/	SHEET 1 OF 2	
16:1	_CXXX\C66XX\		
SIZE	CAGE CODE	DRAWING NO.	REV.
C	30990	C6635	G

A

A

$\left( \begin{smallmatrix} .065 \\ [1.651] \end{smallmatrix} \right)$   $\left( \begin{smallmatrix} .056 \\ [1.422] \end{smallmatrix} \right)$

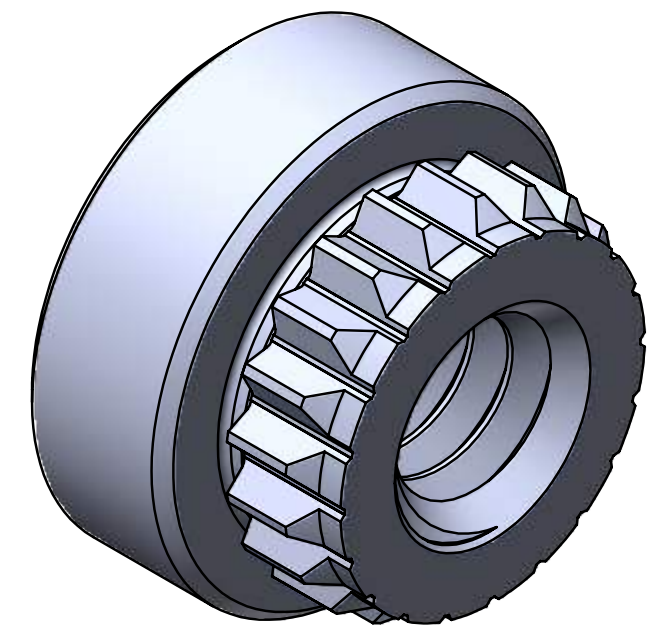
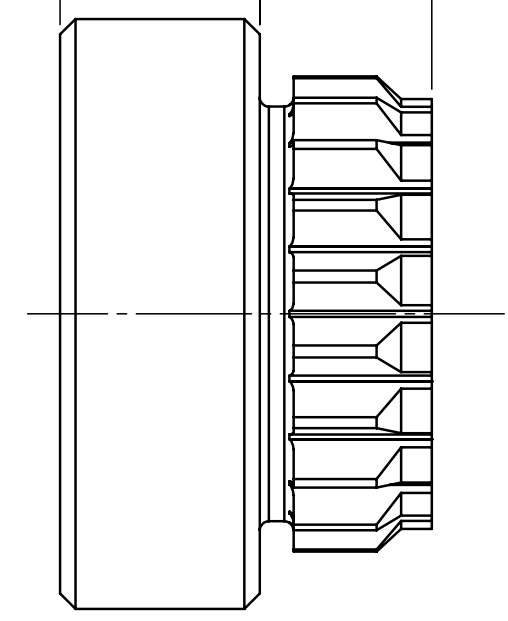

-2 CONFIGURATION

$\left( \begin{smallmatrix} .065 \\ [1.651] \end{smallmatrix} \right)$   $\left( \begin{smallmatrix} .102 \\ [2.591] \end{smallmatrix} \right)$

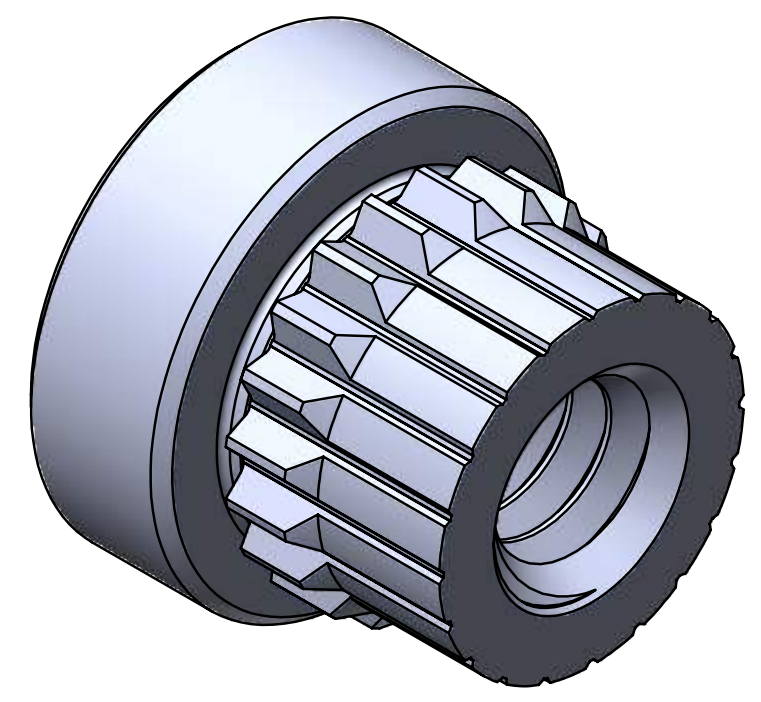
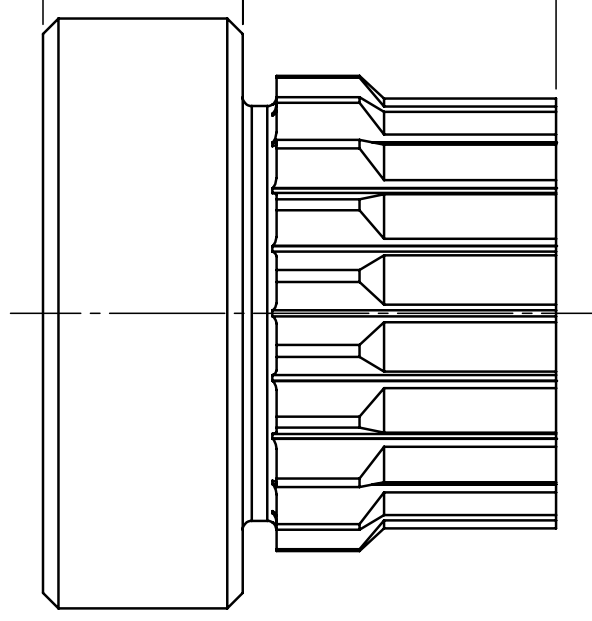

-4 CONFIGURATION

$\left( \begin{smallmatrix} .065 \\ [1.651] \end{smallmatrix} \right)$   $\left( \begin{smallmatrix} .033 \\ [0.838] \end{smallmatrix} \right)$

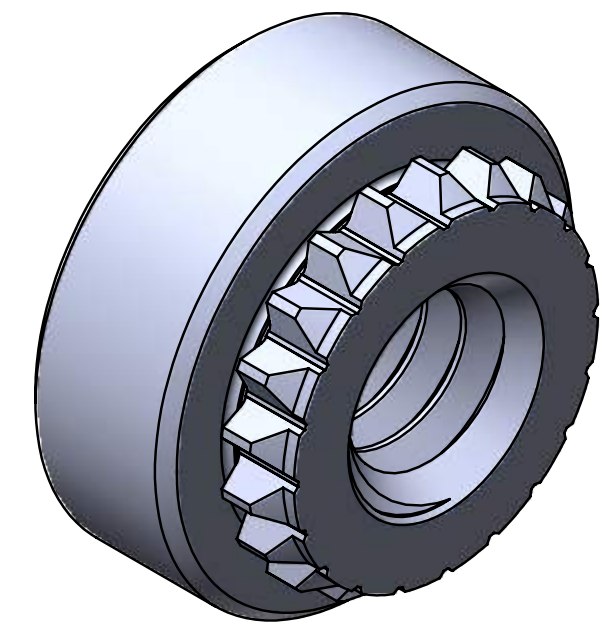
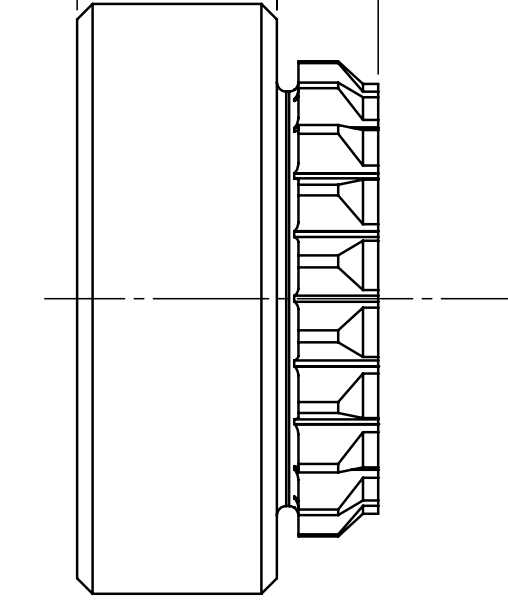

-6 CONFIGURATION

$\left( \begin{smallmatrix} .065 \\ [1.651] \end{smallmatrix} \right)$   $\left( \begin{smallmatrix} .073 \\ [1.854] \end{smallmatrix} \right)$

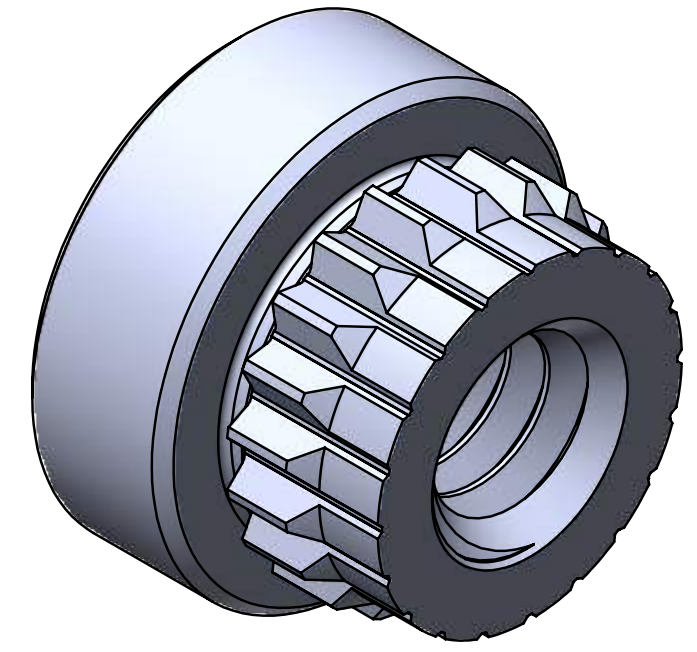
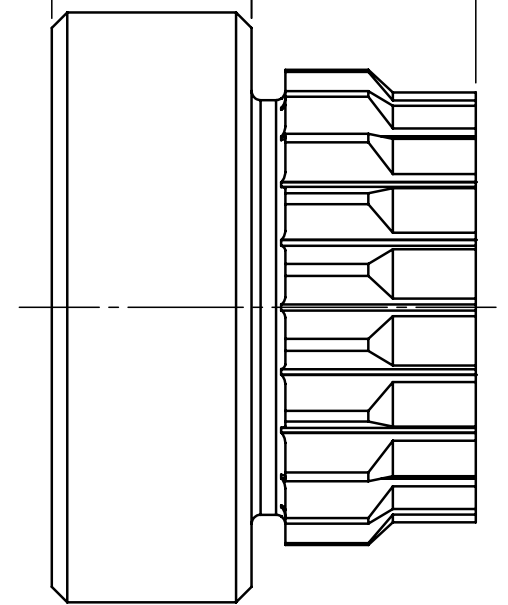

-8 CONFIGURATION

$\left( \begin{smallmatrix} .065 \\ [1.651] \end{smallmatrix} \right)$   $\left( \begin{smallmatrix} .125 \\ [3.175] \end{smallmatrix} \right)$

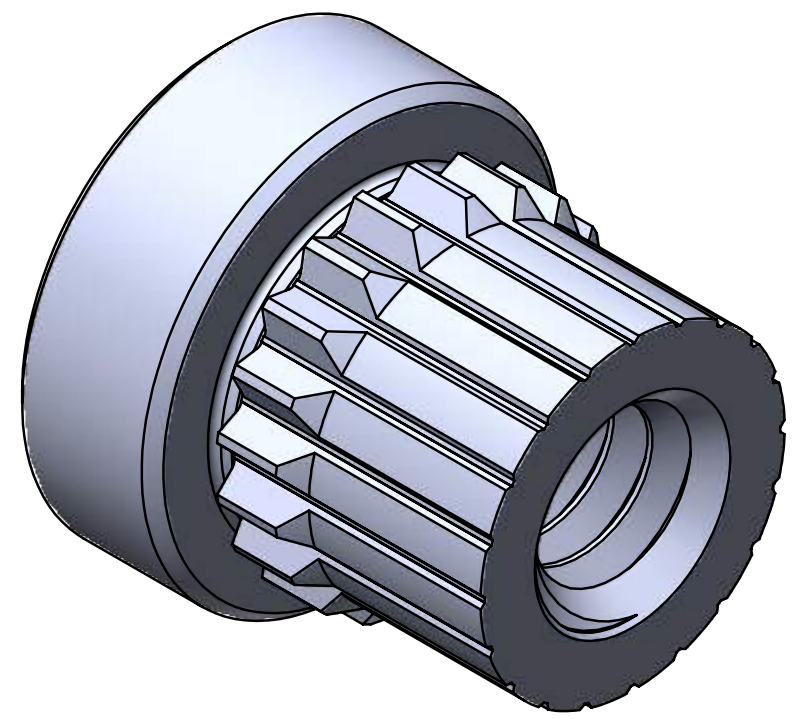
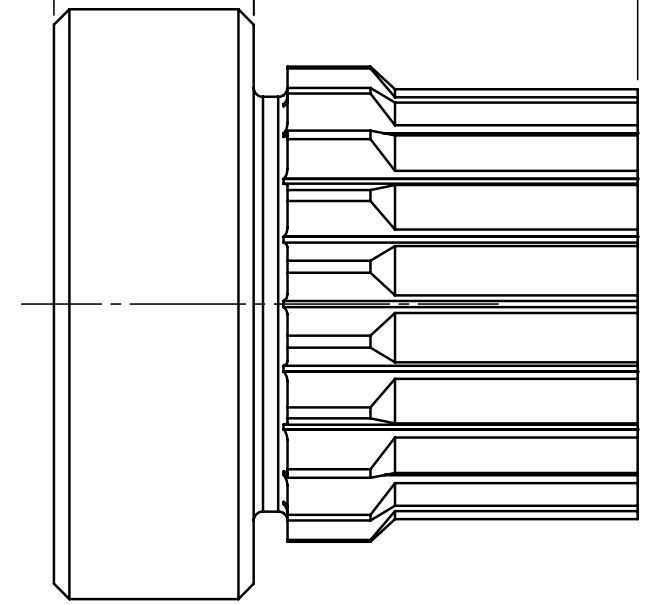

-10 CONFIGURATION

$\left( \begin{smallmatrix} .065 \\ [1.651] \end{smallmatrix} \right)$   $\left( \begin{smallmatrix} .167 \\ [4.242] \end{smallmatrix} \right)$

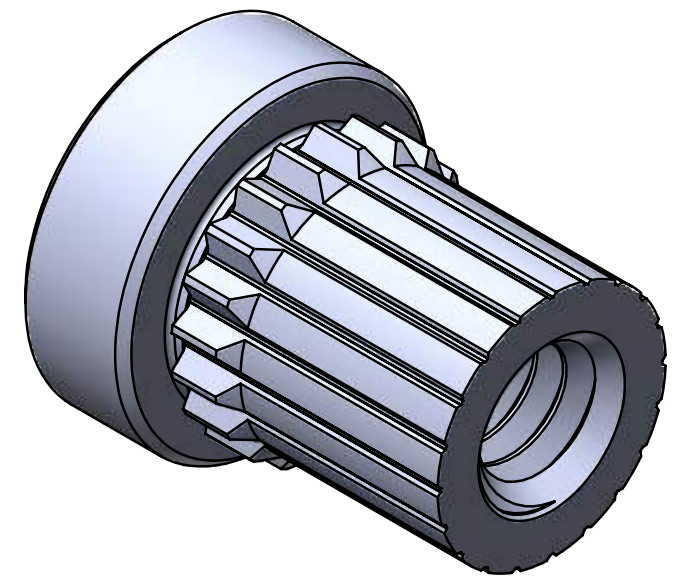
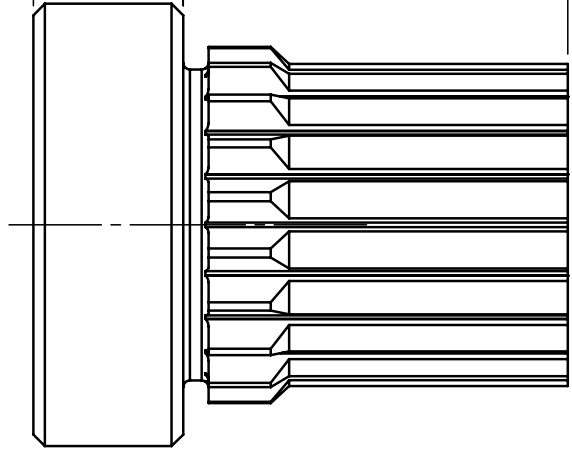

-12 CONFIGURATION

SCALE	SUB-DIRECTORY/		SHEET 2 OF 2
16:1	_CXXXX\C66XX\		
SIZE	CAGE CODE	DRAWING NO.	REV.
C	30990	C6635	G